

PIER 1 - SN 016-1000
Looking South

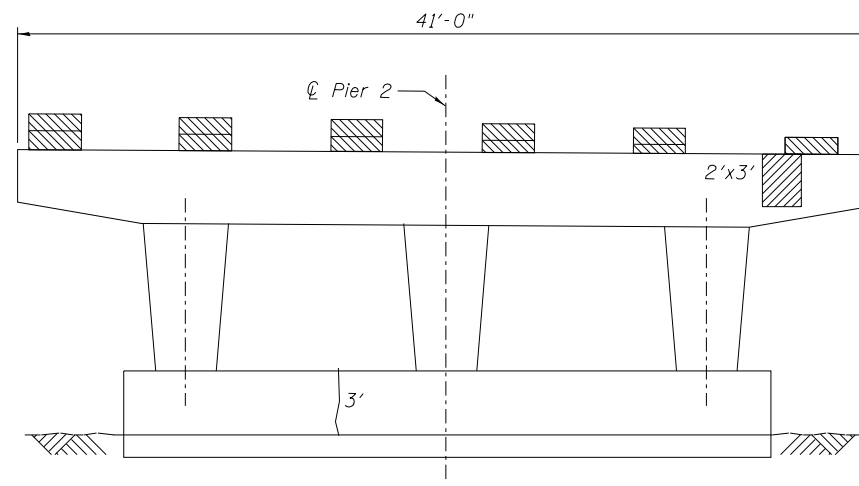

PIER 2 - SN 016-1000
Looking South

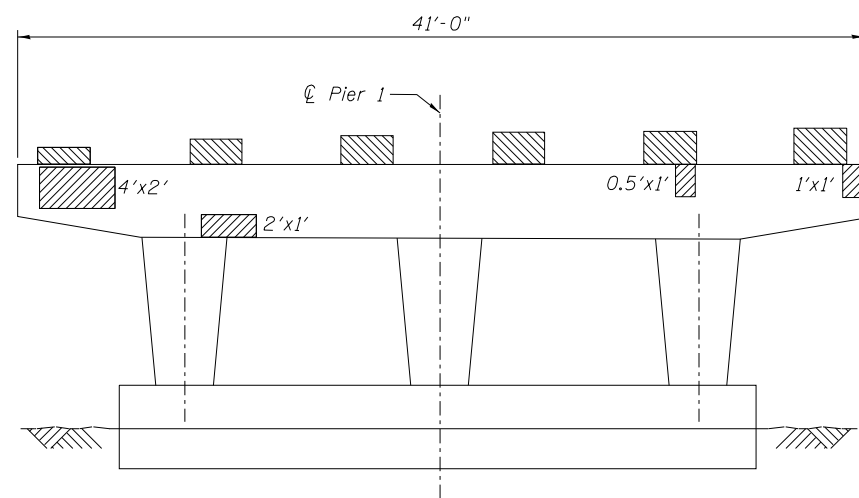

PIER 1 - SN 016-1000
Looking North

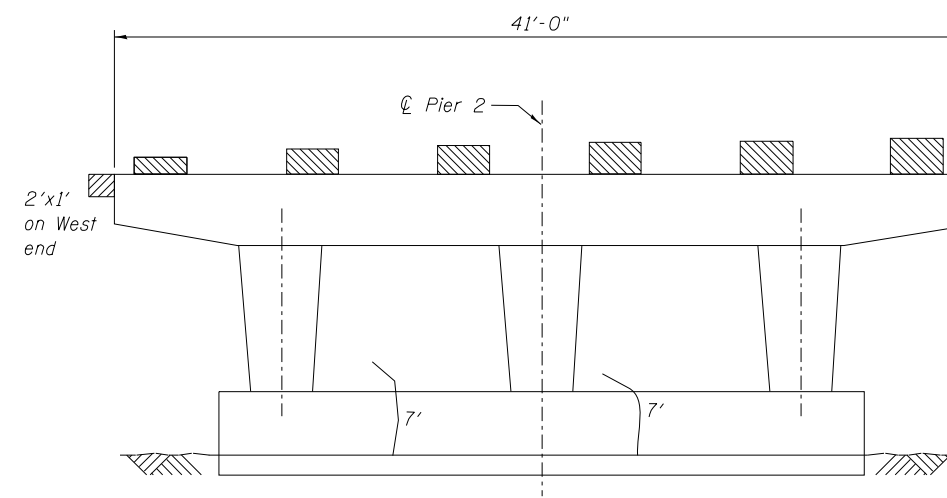

PIER 2 - SN 016-1000
Looking North

NOTES:

- Actual quantities of repairs shall be approved by the Engineer.
- Existing reinforcement shall be cleaned and incorporated into the new construction. Cost included with "Concrete Removal".

LEGEND

- Concrete Removal
- Structural Repair of Concrete (Depth Equal to or Less Than 5 Inches)
- Epoxy Crack Injection

BILL OF MATERIAL

ITEM	UNIT	TOTAL
Concrete Removal	Cu. Yd.	2.6
Structural Repair of Concrete (Depth Equal to or Less Than 5 Inches)	Sq. Ft.	22
Epoxy Crack Injection	Foot	17

benesch
engineers · scientists · planners

Alfred Benesch & Company
205 North Michigan Avenue, Suite 2400
Chicago, Illinois 60601
312-565-0450 Job No. 10093

FILE NAME =	USER NAME = tjenicke	DESIGNED - RMM	REVISED -
		CHECKED - DJM	REVISED -
0161000.60J16.037.pierrepair.SB.dgn	PLOT SCALE =	DRAWN - FSM	REVISED -
	PLOT DATE = 12/20/2012	CHECKED - RMM	REVISED -

STATE OF ILLINOIS
DEPARTMENT OF TRANSPORTATION

PIER CONCRETE REMOVAL AND REPAIR DETAILS
STRUCTURE NO. 016-1000/1001

SHEET NO. SA37 OF SA40 SHEETS

F.A.P. RTE.	SECTION	COUNTY	TOTAL SHEETS	SHEET NO.
372	2013-038B-R	COOK	821	285
CONTRACT NO. 60J16			ILLINOIS FED. AID PROJECT	

X:\1000005\100093\Eng_Docs_Phase_1\1\SN_016_1000_1001_1st_Ave_over_47th_St\Final\0161000_60J16_037_pierrepair_SB.dgn 2:28:25 PM 6/23/2014