

# *Grizzly* **Industrial, Inc.**®

## **1 HP CANISTER DUST COLLECTOR MODEL G0583 INSTRUCTION MANUAL**



COPYRIGHT © JANUARY, 2005 BY GRIZZLY INDUSTRIAL, INC., REVISED AUGUST, 2011 (TS)

**WARNING: NO PORTION OF THIS MANUAL MAY BE REPRODUCED IN ANY SHAPE  
OR FORM WITHOUT THE WRITTEN APPROVAL OF GRIZZLY INDUSTRIAL, INC.**

#CR6902 PRINTED IN TAIWAN

# WARNING

Some dust created by power sanding, sawing, grinding, drilling, and other construction activities contains chemicals known to the State of California to cause cancer, birth defects or other reproductive harm. Some examples of these chemicals are:

- Lead from lead-based paints.
- Crystalline silica from bricks, cement, and other masonry products.
- Arsenic and chromium from chemically treated lumber.

Your risk from these exposures varies, depending on how often you do this type of work. To reduce your exposure to these chemicals: work in a well ventilated area, and work with approved safety equipment, such as those dust masks that are specially designed to filter out microscopic particles.

# Table of Contents

- INTRODUCTION..... 2**
  - Foreword ..... 2
  - Contact Info ..... 2
  - Identification ..... 4
- SECTION 1: SAFETY..... 5**
  - Additional Safety for Canister Dust Collectors ..... 7
- SECTION 2: CIRCUIT REQUIREMENTS ..... 8**
  - 110/220V Operation ..... 8
- SECTION 3: SET UP ..... 10**
  - Unpacking ..... 10
  - Inventory..... 10
  - Site Considerations ..... 11
  - Hardware Recognition Chart..... 12
  - Base and Supports..... 13
  - Canister Filter..... 14
  - Collection Bag ..... 15
- SECTION 4: COLLECTION SYSTEM..... 16**
  - General..... 16
  - Material Selection..... 16
- SECTION 5: OPERATION..... 20**
  - Operation Safety ..... 20
  - Test Run..... 20
  - General..... 20
- SECTION 6: MAINTENANCE..... 21**
  - Schedule ..... 21
  - Lubrication..... 21
  - Bag and Canister Cleaning ..... 21
  - G0583 Parts Breakdown ..... 24
  - Canister Breakdown ..... 25
  - Parts List ..... 26
  - Accessories ..... 27

# INTRODUCTION

---

---

## Foreword

---

---

Grizzly Industrial, Inc. is proud to offer the Model G0583 1 HP Canister Dust Collector. This machine is part of Grizzly's growing family of fine machinery. When used according to the guidelines stated in this manual, you can expect years of trouble-free, enjoyable operation.

We are also pleased to provide this manual with the Model G0583. It was written to guide you through assembly, review safety considerations, and cover general operating procedures. It represents our latest effort to produce the best documentation possible.



## Contact Info

---

---

If you have any comments or criticisms that you feel we should address in our next printing, please write to us at:

Grizzly Industrial, Inc.  
% Technical Documentation  
P.O. Box 2069  
Bellingham, WA 98227

Most important, we stand behind our machines. We have excellent regional service departments at your disposal should the need arise.

If you have any service questions or parts requests, please call or write to us at the location listed below.

Grizzly Industrial, Inc  
1203 Lycoming Mall Circle  
Muncy, PA 17756  
Phone:(570) 546-9663  
Fax:(800) 438-5901  
E-Mail: techsupport@grizzly.com  
Web Site: <http://www.grizzly.com>

The specifications, drawings, and photographs illustrated in this manual represent the Model G0583 as supplied when the manual was prepared. However, owing to Grizzly's policy of continuous improvement, changes may be made at any time with no obligation on the part of Grizzly. For your convenience, we always keep current Grizzly manuals available on our website at [www.grizzly.com](http://www.grizzly.com). Any updates to your machine will be reflected in these manuals as soon as they are complete.





# MACHINE DATA SHEET

Customer Service #: (570) 546-9663 • To Order Call: (800) 523-4777 • Fax #: (800) 438-5901

## MODEL G0583 1 HP CANISTER DUST COLLECTOR

Design Type ..... Single Stage Floor Model

### Overall Dimensions:

Base ..... 15 $\frac{1}{4}$ " x 26"  
Height ..... 58 $\frac{5}{8}$ "  
Machine Size ..... 15 $\frac{3}{4}$ " D x 30 $\frac{3}{4}$ " L x 58 $\frac{5}{8}$ " H  
Shipping Weight (Machine) ..... 59.4 lbs.  
Shipping Weight (Canister) ..... 17.6 lbs.  
Net Weight (Machine) ..... 52.8 lbs.  
Net Weight (Canister) ..... 13 lbs.  
1<sup>st</sup> Box Size (Machine) ..... 28 $\frac{3}{4}$ " L x 16 $\frac{1}{4}$ " W x 18 $\frac{1}{8}$ " H  
2<sup>nd</sup> Box Size (Canister) ..... 17 $\frac{3}{8}$ " L x 17 $\frac{3}{8}$ " W x 28 $\frac{3}{8}$ " H

### Specifications:

Intake Hole Size ..... 4"  
Intake Adapter Hole Size ..... 4" Elbow Fitting  
Canister Size ..... 14 $\frac{1}{2}$ " Diameter x 23 $\frac{5}{8}$ " H  
Canister Material ..... Wire Reinforced Pleated Filter Paper  
Canister Filtration Rating ..... 2.5 Micron  
Storage Bag Size ..... 14 $\frac{3}{4}$ " Diameter x 24 $\frac{3}{8}$ "  
Storage Bag Material ..... Heavy Duty Plastic  
Storage Bag Capacity ..... 2.1 Cubic Feet  
Air Suction Capacity (With 4" Elbow) ..... 630 CFM  
Air Suction Capacity (Without 4" Elbow) ..... 800 CFM  
Static Pressure (Inches of Water) ..... 3.3"

### Construction:

Base ..... Sheet Metal with Casters  
Body ..... Sheet Metal  
Impeller Type ..... Radial Fin  
Impeller Construction .....  $\frac{3}{32}$ " Steel, 7 Riveted Fins  
Impeller Size ..... 9"

### Motor:

Type ..... TEFC (Aluminum finned)  
Horsepower ..... 1 HP  
Phase / Voltage ..... Single Phase 110V / 220V (Prewired 110V)  
Amps ..... 9A/4.5A  
Cycle/ RPM ..... 60 Hertz / 3450 RPM  
Switch ..... On / Off Paddle Switch  
Bearings ..... Sealed & Permanently Lubricated

*Specifications, while deemed accurate, are not guaranteed.*

# Identification



1. Canister Filter Cleaning Handle
2. Canister Filter
3. 4" Duct Elbow
4. Clear Dust Storage Bag
5. Power Switch w/ Safety Key
6. Roller Base
7. Handle



# SECTION 1: SAFETY

## WARNING

### For Your Own Safety, Read Instruction Manual Before Operating this Machine

The purpose of safety symbols is to attract your attention to possible hazardous conditions. This manual uses a series of symbols and signal words which are intended to convey the level of importance of the safety messages. The progression of symbols is described below. Remember that safety messages by themselves do not eliminate danger and are not a substitute for proper accident prevention measures.



Indicates an imminently hazardous situation which, if not avoided, **WILL** result in death or serious injury.



Indicates a potentially hazardous situation which, if not avoided, **COULD** result in death or serious injury.



Indicates a potentially hazardous situation which, if not avoided, **MAY** result in minor or moderate injury. It may also be used to alert against unsafe practices.

**NOTICE**

This symbol is used to alert the user to useful information about proper operation of the machine.

## WARNING

### Safety Instructions for Machinery

- 1. READ THROUGH THE ENTIRE MANUAL BEFORE STARTING MACHINERY.** Machinery presents serious injury hazards to untrained users.
- 2. ALWAYS USE ANSI APPROVED SAFETY GLASSES WHEN OPERATING MACHINERY.** Everyday eyeglasses only have impact resistant lenses, they are NOT safety glasses.
- 3. ALWAYS WEAR AN ANSI APPROVED RESPIRATOR WHEN OPERATING MACHINERY THAT PRODUCES DUST.** Wood dust is a carcinogen and can cause cancer and severe respiratory illnesses.
- 4. ALWAYS USE HEARING PROTECTION WHEN OPERATING MACHINERY.** Machinery noise can cause permanent hearing damage.
- 5. WEAR PROPER APPAREL. DO NOT** wear loose clothing, gloves, neckties, rings, or jewelry which may get caught in moving parts. Wear protective hair covering to contain long hair and wear non-slip footwear.
- 6. NEVER OPERATE MACHINERY WHEN TIRED, OR UNDER THE INFLUENCE OF DRUGS OR ALCOHOL.** Be mentally alert at all times when running machinery.

# WARNING

## Safety Instructions for Machinery

7. **ONLY ALLOW TRAINED AND PROPERLY SUPERVISED PERSONNEL TO OPERATE MACHINERY.** Make sure operation instructions are safe and clearly understood.
8. **KEEP CHILDREN AND VISITORS AWAY.** Keep all children and visitors a safe distance from the work area.
9. **MAKE WORKSHOP CHILD PROOF.** Use padlocks, master switches, and remove start switch keys.
10. **NEVER LEAVE WHEN MACHINE IS RUNNING.** Turn power *OFF* and allow all moving parts to come to a complete stop before leaving machine unattended.
11. **DO NOT USE IN DANGEROUS ENVIRONMENTS.** DO NOT use machinery in damp, wet locations, or where any flammable or noxious fumes may exist.
12. **KEEP WORK AREA CLEAN AND WELL LIT.** Clutter and dark shadows may cause accidents.
13. **USE A GROUNDED EXTENSION CORD RATED FOR THE MACHINE AMPERAGE.** Undersized cords overheat and lose power. Replace extension cords if they become damaged. DO NOT use extension cords for 220V machinery.
14. **ALWAYS DISCONNECT FROM POWER SOURCE BEFORE SERVICING MACHINERY.** Make sure switch is in OFF position before reconnecting.
15. **MAINTAIN MACHINERY WITH CARE.** Keep blades sharp and clean for best and safest performance. Follow instructions for lubricating and changing accessories.
16. **MAKE SURE GUARDS ARE IN PLACE AND WORK CORRECTLY BEFORE USING MACHINERY.**
17. **REMOVE ADJUSTING KEYS AND WRENCHES.** Make a habit of checking for keys and adjusting wrenches before turning machinery *ON*.
18. **CHECK FOR DAMAGED PARTS BEFORE USING MACHINERY.** Check for binding and alignment of parts, broken parts, part mounting, loose bolts, and any other conditions that may affect machine operation. Repair or replace damaged parts.
19. **USE RECOMMENDED ACCESSORIES.** Refer to the instruction manual for recommended accessories. The use of improper accessories may cause risk of injury.
20. **DO NOT FORCE MACHINERY.** Work at the speed for which the machine or accessory was designed.
21. **SECURE WORKPIECE.** Use clamps or a vise to hold the workpiece when practical. A secured workpiece protects your hands and frees both hands to operate the machine.
22. **DO NOT OVERREACH.** Keep proper footing and balance at all times.
23. **MANY MACHINES WILL EJECT THE WORKPIECE TOWARD THE OPERATOR.** Know and avoid conditions that cause the workpiece to "kickback."
24. **ALWAYS LOCK MOBILE BASES BEFORE OPERATING MACHINERY.**



# WARNING

## Additional Safety for Canister Dust Collectors

- 1. MACHINE USE.** Do not use this dust collector to pick up liquids and metal scrap including, but not limited to, nails and filings. Metallic debris will contact the spinning impeller and could spark. The spark could then cause a sawdust explosion or severe fire hazard. Also, do not pick up material which cannot safely pass through the impeller such as solid wood scraps.
- 2. KEEPING FINGERS SAFE.** Do not place your hands or tools near the open inlet during operation for any reason including, but not limited to, unclogging material and testing suction. The impeller could cause serious damage to body parts if touched while spinning.
- 3. SAFE SERVICING.** Disconnect power and allow impeller to come to a complete stop before servicing or working on the dust collector ducting system.
- 4. SUSPENDED DUST PARTICLES AND IGNITION SOURCES.** Do not operate the dust collector in areas where explosion risks would be high if dust were dispersed into the area. Areas of high risk include, but are not limited to, areas near pilot lights and/or open flames.
- 5. EMPTYING BAGS.** When emptying dust from the collection bags, wear a respirator and safety glasses. Empty dust into an approved container and dispose of properly.
- 6. AVOIDING FIRES.** Do not allow steel to strike against impeller which may produce a spark. Sparks can smolder in wood dust for a long time before fire or flame is detected. If metal contacts metal during operation, immediately turn off the dust collector, unplug the power cord from the outlet or flip the disconnect switch and wait for all moving parts to stop. Remove collection bags and empty the dust into an approved air tight metal container in case of spark. Remedy the metal to metal contact problem before resuming operation.
- 7. OPERATIONAL QUESTIONS.** If at any time you are experiencing difficulties performing the intended operation, stop using the machine! Then contact our service department or ask a qualified expert how the operation should be performed.
- 8. DUST HAZARD.** Be aware that certain woods may cause an allergic reaction in people and animals, especially when exposed to fine dust. Make sure you know what type of wood dust you will be exposed to in case there is a possibility of an allergic reaction. Always wear an approved respirator!

### CAUTION

No list of safety guidelines can be complete. Every shop environment is different. Always consider safety first, as it applies to your individual working conditions. Use this and other machinery with caution and respect. Failure to follow guidelines could result in serious personal injury, damage to equipment or poor work results.

### CAUTION

DO NOT use the dust collector for any other purpose besides collecting dust from connected woodworking machines. A dust collector should NEVER be used as an air cleaner. For safest use, wear a respirator and use an air cleaner in addition to the dust collector.

# SECTION 2: CIRCUIT REQUIREMENTS

## 110/220V Operation

The Model G0583 features a single phase 110V/220V 1 HP motor, which is prewired to 110V.

### Amperage Draw

110V .....	9 Amps
220V .....	4.5 Amps

### Circuit Breaker Requirements

Use the following guidelines when choosing a circuit breaker (circuit breakers rated any higher are not adequate to protect the circuit):

### Circuit Breaker

110V .....	15 Amp
220V .....	10 Amp

Always check to see if the wires in your circuit are capable of handling the amperage draw from your machine, as well as any other machines that could be operating on the same circuit. If you are unsure, consult a qualified electrician.

## **⚠ CAUTION**

A fire may occur if your particular electrical configuration does not comply with local and state codes. The best way to ensure compliance is to check with your local municipality or a qualified electrician.

## Plug and Receptacle Requirements

The motor is prewired to 110V and no plug replacement is required. For 220V connection, rewire the motor as in **Figure 2**, and install a NEMA 6-15 plug (**Figure 1**). You may also “hard-wire” the dust collector directly to your panel, provided you place a disconnect near the machine. Check the electrical codes in your area for specifics on wiring requirements.

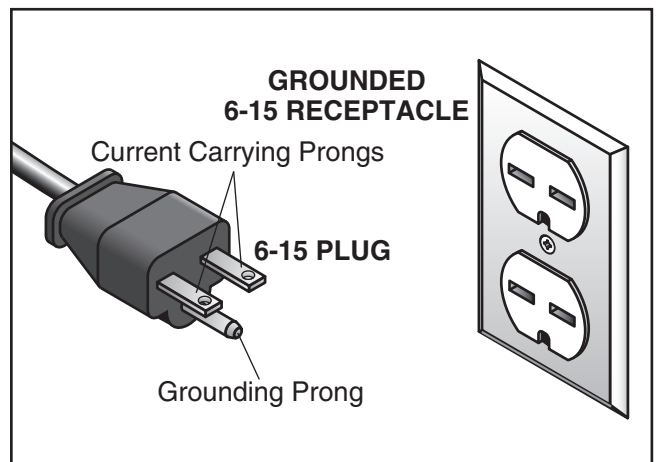

Figure 1. NEMA 6-15 plug and receptacle.

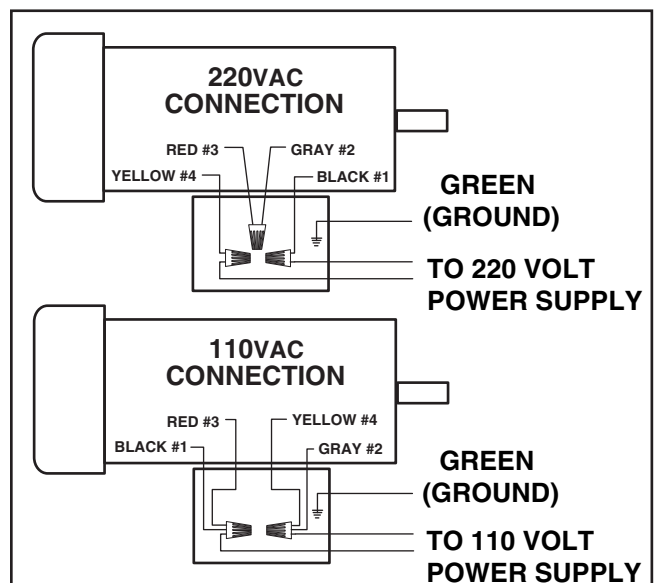

Figure 2. 110V/220V motor wiring diagram.



---

---

## Grounding

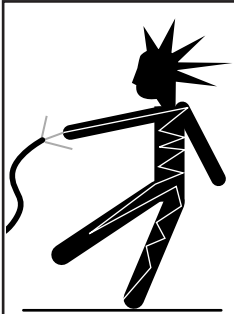

### **⚠️ WARNING**

Electrocution or a fire can result if the machine is not grounded correctly. Make sure all electrical circuits are grounded. **DO NOT** use the machine if it is not grounded.

### ***NOTICE***

The wire on the power cord with green or green and yellow striped insulation is the grounding conductor.

In the event of an electrical short, grounding reduces the risk of electric shock by providing a path of least resistance to disperse electric current. This tool is equipped with a power cord that has an equipment-grounding prong. The outlet must be properly installed and grounded in accordance with all local codes and ordinances.



---

---

## Extension Cords

We do not recommend the use of extension cords with 220V equipment. Instead, arrange the placement of your equipment and the installed wiring to eliminate the need for extension cords. Should the situation be necessary to use an extension, make sure the cord is rated Standard Service (grade S) or better. The extension cord must also contain a ground wire and plug pin. Always repair or replace extension cords when they become worn or damaged.



# SECTION 3: SET UP

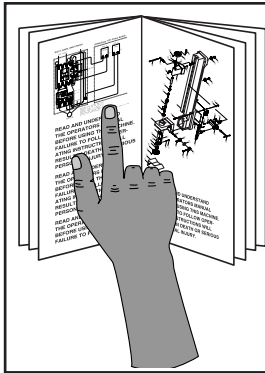

**!WARNING**  
 This machine presents serious injury hazards to untrained users. Read through this entire manual to become familiar with the controls and operations **BEFORE** starting the machine!

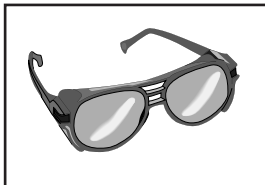

**!WARNING**  
 Wear safety glasses during the entire set up process!

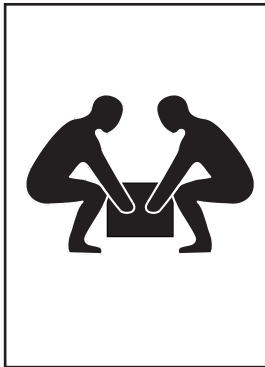

**!WARNING**  
 The Model G0583 is a heavy machine (approximately 60 lbs. shipping weight). **DO NOT** over-exert yourself while unpacking or moving your machine—get assistance.

## Unpacking

Your machine left our warehouse in two carefully packed boxes. If you discover the machine is damaged after you have signed for delivery, *please immediately call Customer Service at (570) 546-9663 for advice.*

Save the containers and all packing materials for possible inspection by the carrier or its agent. *Otherwise, filing a freight claim can be difficult.*

When you are completely satisfied with the condition of the shipment, you should inventory the equipment.



## Items Needed For Set Up

Items Needed for Setup	QTY
Hex Wrench 3mm.....	1
Wrench or Socket 12mm.....	1
#2 Phillips Screwdriver.....	1

## Inventory

After all the parts have been removed from the two boxes, you should have the following items:

Box 1: Canister Components (Figure 3)	QTY
A. Canister Filter .....	1
B. Gasket Bag.....	1
— Wide Foam Strip .....	1
— Narrow Foam Strip.....	1
C. Canister Filter Cleaning Handle .....	1
D. Metal Canister Clamp .....	1



**Figure 3.** Canister filter box components.

# Site Considerations

## Box 2: Main Components (Figure 4)

E.	Elbow 4".....	1
F.	Base.....	1
G.	Clear Dust Storage Bag .....	1
H.	Round Support .....	1
I.	Rectangle Supports .....	2
J.	Swivel Casters .....	2
K.	Fixed Casters .....	2
L.	Impeller/Separator .....	1
M.	Lower Bag Clamp .....	1
N.	Handle .....	1
O.	Hardware Bag.....	1
	— Hex Bolt $\frac{5}{16}$ "-18 x $\frac{1}{2}$ ".....	12
	— Acorn Nut $\frac{5}{16}$ "-18.....	4
	— Flat Washer $\frac{5}{16}$ " .....	2
	— Flat Head Screw $\frac{5}{16}$ "-18 x 1".....	2
	— Flange Screw 10-24 x $\frac{3}{8}$ " .....	1
	— Open-End Wrench 10-12mm.....	1
	— Hex Wrench 5mm .....	1
	— Hex Bolt M6-1.0 x 10.....	4

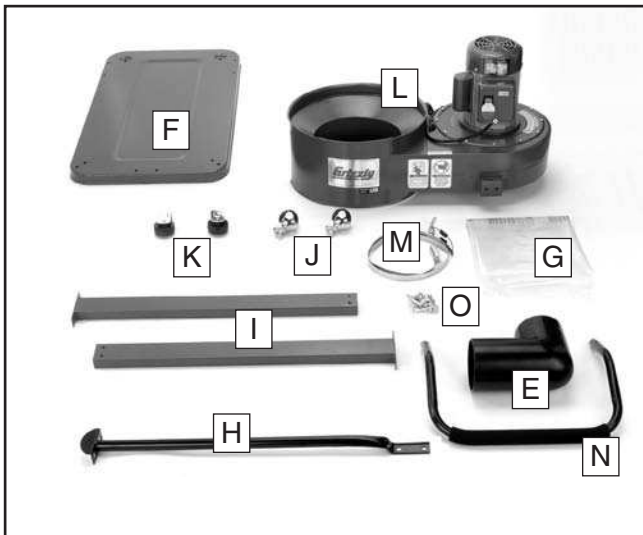

Figure 4. Main box items.

In the event that any non proprietary parts are missing (e.g. a nut or a washer), we would be glad to replace them, or, for the sake of expediency, replacements can be obtained at your local hardware store.



## Working Clearances

Consider existing and anticipated needs, size of material to be processed through each machine, and space for auxiliary stands, work tables or other machinery when establishing a location for the machine. See **Figure 5** for the machine footprint dimensions of the Model G0583.

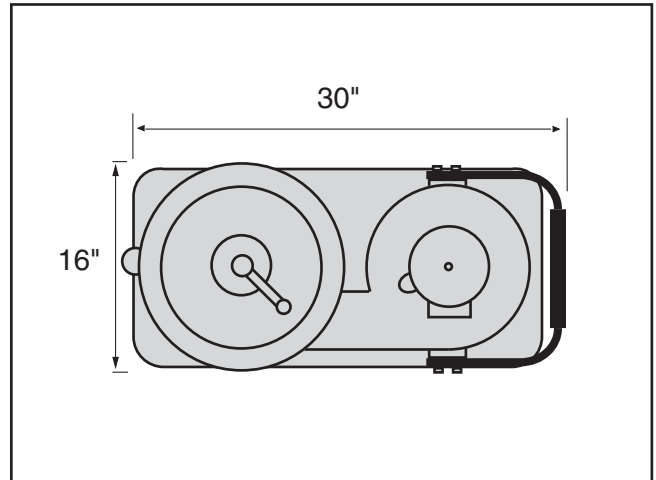

Figure 5. Dust collector footprint.







	<p><b>!WARNING</b>  <b>Unsupervised children and visitors inside your shop could receive serious personal injury. Ensure child and visitor safety by keeping all entrances to the shop locked at all times. DO NOT allow unsupervised children or visitors in the shop at any time.</b></p>
--	---





# Hardware Recognition Chart

USE THIS CHART TO MATCH UP  
HARDWARE DURING THE ASSEMBLY  
PROCESS!



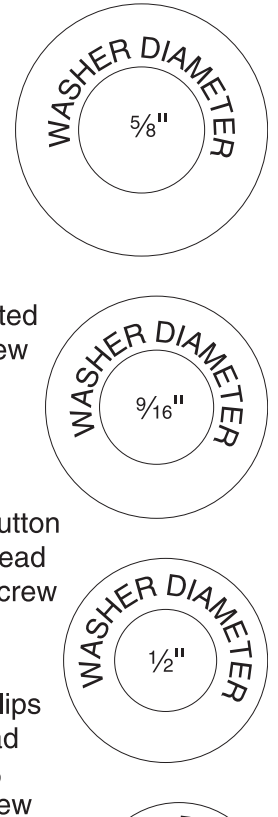
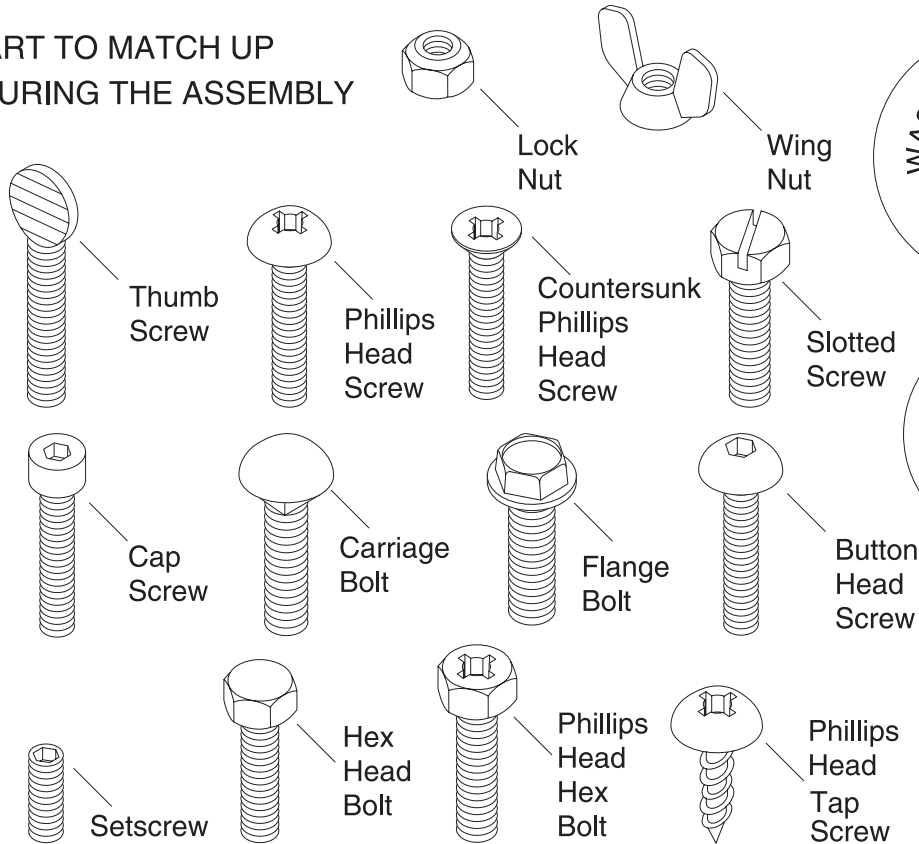

MEASURE BOLT DIAMETER BY PLACING INSIDE CIRCLE

-  #10
-  1/4"
-  5/16"
-  3/8"
-  7/16"
-  1/2"

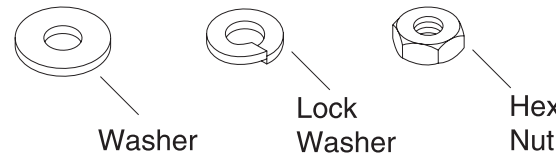

-  5/8"
-  4mm



-  6mm
-  8mm
-  10mm
-  12mm
-  16mm

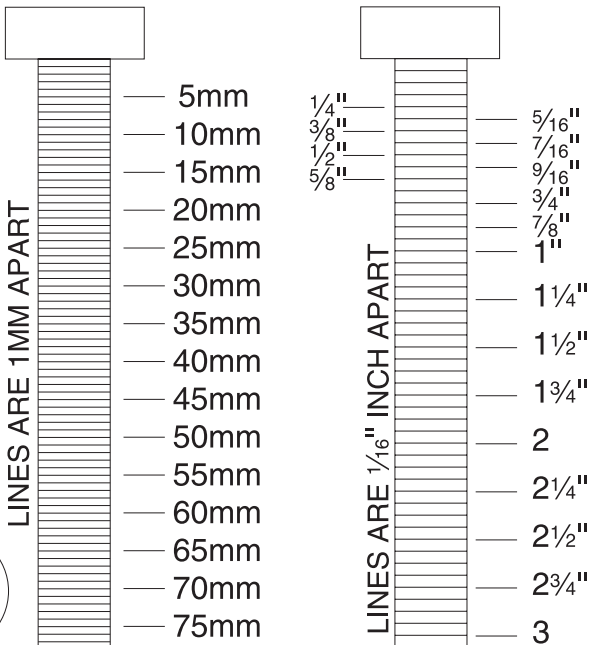

WASHERS ARE MEASURED BY THE INSIDE DIAMETER

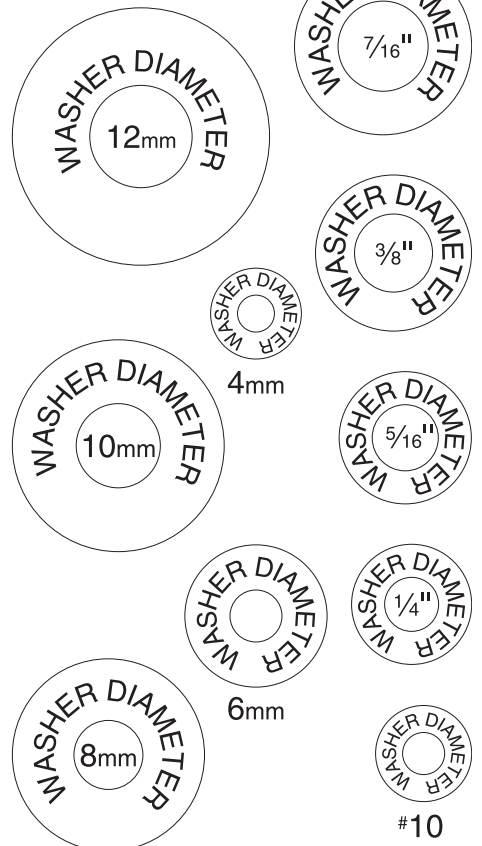

# Base and Supports

<b>Components and Hardware Needed:</b>	<b>QTY</b>
Base .....	1
Casters .....	4
Round Support .....	1
Rectangle Support.....	2
Impeller/Separator .....	2
Handle .....	1
Hex Bolts $\frac{5}{16}$ "-18 x $\frac{1}{2}$ " .....	6
Hex Bolts M6-1.0 x 10.....	4
Acorn Nuts $\frac{5}{16}$ "-18 .....	4
Flat Head Screws M6-1.0 x 10.....	2
Phlips Screw 10-24 x $\frac{3}{8}$ " .....	1
Flat Washers $\frac{5}{16}$ "-18.....	2

**Tools Needed:**

Wrench or Socket 12mm.....	1
#2 Phillips Screwdriver .....	1

**To assemble the dust collector base:**

1. **Make sure the dust collector motor is unplugged!**
2. Install the the casters with the four  $\frac{5}{16}$ "-18 acorn nuts and washers. (see **Figure 6**).



**Figure 6.** Installing casters.

4. Place the round and rectangle supports on the base and install with six  $\frac{5}{16}$ "-18 x  $\frac{5}{16}$ " hex bolts (see **Figure 7**).



**Figure 7.** Impeller/separator supports.

5. Align the impeller/separator assembly with the supports, and install six  $\frac{5}{16}$ "-18 x  $\frac{1}{2}$ " hex bolts (see **Figure 8**).
6. Position the elbow as shown in **Figure 8**, and secure it in place with the #10-24 x  $\frac{3}{8}$ " phlips head screw.
7. Position the handle as shown in **Figure 8**, and secure it in place with two M6-1 x 10 flat head screws.



**Figure 8.** Impeller/separator attached to base.



# Canister Filter

Components and Hardware Needed:	QTY
Canister Filter.....	1
Handle.....	1
Metal Canister Clamp.....	1
Narrow Foam Strip.....	1

Tools Needed:	
Hex Wrench 3mm.....	1

## To install the canister:

1. Secure the narrow foam strip around the outside top rim of the collector as shown in **Figure 9**.



**Figure 9.** Narrow foam strip.

2. Trim the excess foam strip so the ends come together evenly as shown in **Figure 9**.

3. Install the handle onto the top of the canister and tighten the set screw against the flat of the shaft (**Figure 10**).

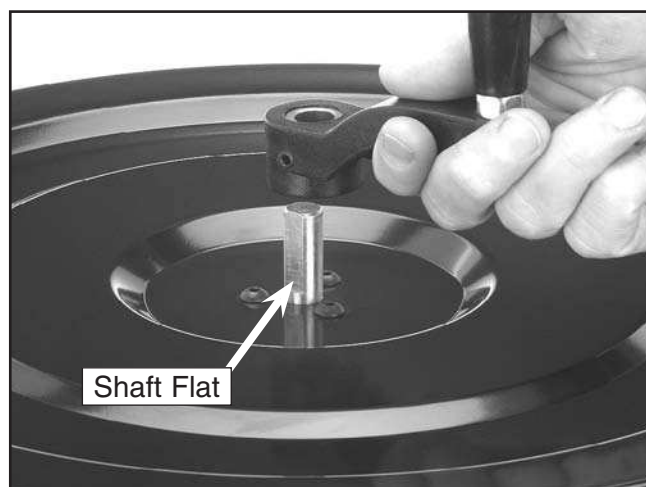

**Figure 10.** Installing canister handle.

4. Place the canister on top of the collector.
5. Position the metal canister clamp around the bottom of the canister filter, so it will compress around the foam strip (**Figure 11**), and latch the clamp closed.



**Figure 11.** Installed and secured canister filter.





# Collection Bag

Components and Hardware Needed:	QTY
Clear Collection Bag.....	1
Lower Bag Clamp.....	1
Wide Foam Strip.....	1

## To install the collection bag:

1. Secure the wide foam strip around the outside bottom rim of the collector and trim the excess (**Figure 12**).



**Figure 12.** Installed and trimmed wide foam strip.

2. Slide the clear collection bag around the bottom of the collector so the rim of the bag overlaps onto the foam strip.

3. Tighten the lower bag clamp around the wide foam strip to seal and secure the lower collection bag (**Figure 13**).



**Figure 13.** Dust collection bag installed.



# SECTION 4: COLLECTION SYSTEM

---

---

## General

---

The Model G0583 is designed to be a single-machine dust collector. Locate the dust collector where it will not interfere with the workpiece being processed, and no more than 10' of ducting is used, otherwise the CFM will be reduced. To solve dust collection questions, Grizzly offers a guide book entitled *Canister Dust Collection Basics* that will help you design your system.

Whatever system you choose, always make sure there are no open flames or pilot lights in the same room as the dust collector. There is a risk of explosion if dust is dispersed into the air.



## Material Selection

---

You have many choices regarding dust collection ducting, but flexible hose is the most common. However, be aware that there is a fire or explosion hazard if plastic duct material is used for dust collection without being grounded against static electrical charge build-up. This topic will be discussed later in the manual.

### Metal Rigid Duct

Metal ducting comes in many varieties, make sure that what you use is suitable for dust collection. Advantages of metal ducting is its conductivity and that it does not contribute to static electrical charge build-up. However, static charges are still produced when dust particles strike other dust particles as they move through the ducting. Since metal ducting is a conductor, it can be grounded quite easily to dissipate any static electrical charges. However, metal ducting is generally more expensive than plastic ducting and it is not usually airtight unless specifically manufactured for dust collection. Specially manufactured metal ducting, on the other hand, is quite expensive. Metal ducting is also generally more difficult to cut and assemble.

### Plastic Flexible Duct

Flexible rubber hose, polyethylene, plastic flex-hose and other flexible ribbed hose is generally used for short runs, small shops, and at rigid duct-to-tool connections. There are many different types of flex hose on the market today. These are manufactured from materials such as polyethylene, PVC, cloth hose dipped in rubber and even metal, including steel and aluminum.

There are also many kinds of pure plastic flexible hose, such as non-perforated drainage type hose and dryer vent hose. Drainage type hose, while being economical, does not quite have the flexibility required for dust collection. The inside of the duct is also deeply corrugated and can increase the static pressure loss by as much as 50% over smooth wall duct. Dryer vent hose, while being completely flexible, is non-resistant to abrasion and has a tendency to collapse in a negative pressure system.

If using flex-hose, you should choose one of the many types that are designed specifically for the movement of solid particles, i.e. dust, grains and plastics. However, the cost of specifically designed flexible duct can vary greatly. Grizzly offers polyethylene hose, which is well suited for the removal of particulate matter, especially sawdust, since it is durable and completely flexible. Polyethylene is also very economical and available in a wide variety of diameters and lengths for most applications.

### Plastic Rigid Duct

The popularity of plastic duct is due to the fact that it is an economical and readily available product. It is also simple to assemble and easily sealed against air loss. The primary disadvantage of plastic duct for Canister Dust collection, whether black ABS or white PVC and even rubber or polyethylene flex-hose, is the inherent danger of static electrical build-up.



---

---

# Duct Grounding

Since plastic hose is abundant, relatively inexpensive, easily assembled and air tight, it is a very popular material for conveying dust from woodworking machines to the dust collector. We recommend using flexible hose (flex-hose) to connect the woodworking machine to the dust collector. However, plastic flex-hose and plastic ducting are an insulator, and dust particles moving against the walls of the plastic duct create a static electrical build up. This charge will build until it discharges to a ground. If a grounding medium is not available to prevent static electrical build up, the electrical charge will arc to the nearest grounded source. This electrical discharge may cause an explosion and subsequent fire inside the system.

To protect against static electrical build up inside a non-conducting duct, a bare copper wire should be placed inside the duct along its length and grounded to the dust collector. You must also confirm that the dust collector is continuously grounded through the electrical circuit to the electric service panel.

	<p><b>! WARNING</b> Always guard against static electrical build up by grounding all dust collection lines.</p>
--	---

Be sure that you extend the bare copper wire down all branches of the system. Do not forget to connect the wires to each other with wire nuts when two branches meet at a “Y” or “T” connection.

Ensure that the entire system is grounded. If using plastic blast gates to direct air flow, the grounding wire must be jumped (**Figure 14**) around the blast gate without interruption to the grounding system.

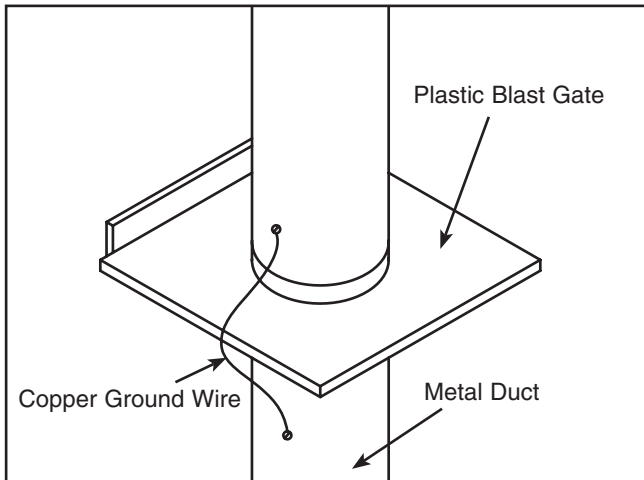

**Figure 14.** Ground jumper wire when using plastic blast gates or elbows and metal duct.

We also recommend wrapping the outside of all plastic ducts with bare copper wire to ground the outside of the system against static electrical build up. Wire connections at Y's and T's should be made with wire nuts.

Attach the bare ground wire to each stationary woodworking machine and attach the canister dust collector frame with a ground screw as shown in **Figure 15**. Ensure that each machine is continuously grounded to the grounding terminal in your electric service panel.

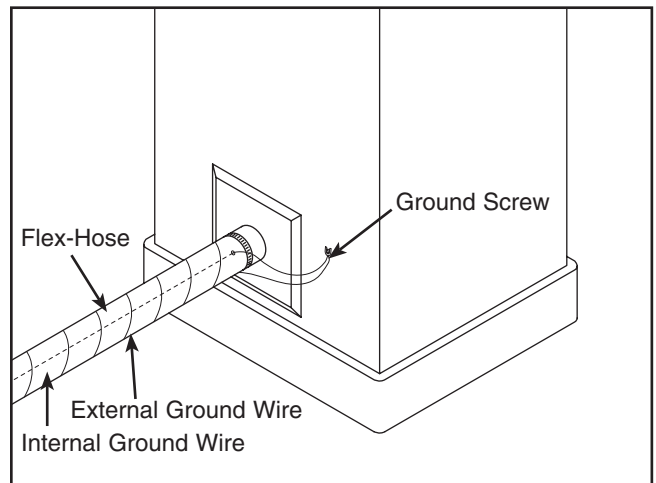

**Figure 15.** Flex-hose grounded to machine.



# Ducting Suggestions

---

---

This dust collector is intended for single machine use and not designed to draw dust through long runs and multiple ports simultaneously. We do not recommend using ducting any longer than 10 feet. Otherwise, dust collection efficiency will be greatly reduced. However, still consider these general guidelines for efficient dust collection:

1. Machines that produce the most sawdust should have the shortest run of ducting between the dust collector and the machine. These machines include thickness planers, shapers, sanders, and bandsaws.
2. Ideally, you should design your shop layout so machines will have the shortest possible run to the dust collector.

3. Keep ducting directional changes to a minimum. The more directional change fittings you use, the greater the loss of overall pressure.
4. Gradual directional changes are more efficient than sudden directional changes (i.e. use the largest corner radius possible when changing hose or pipe direction).
5. The simpler the system, the more efficient and less costly it will be.



# SECTION 5: OPERATION

## Operation Safety

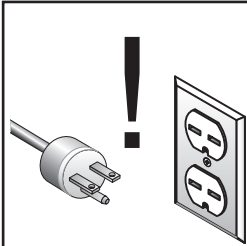

### **! WARNING**

Disconnect power to the machine when performing any maintenance, assembly or adjustments. Failure to do this may result in serious personal injury.

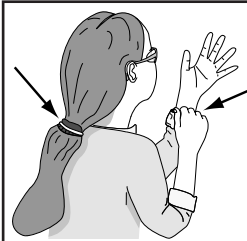

### **! WARNING**

Keep loose clothing rolled up and out of the way of machinery and keep hair pulled back.

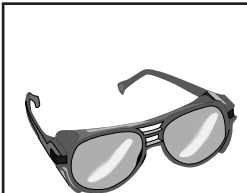

### **! WARNING**

Wear safety glasses during the entire operations process. Failure to comply may result in serious personal injury.

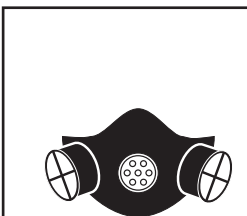

### **! CAUTION**

Always wear a respirator when operating your dust collector. This machine circulates sawdust which may cause allergic reactions or respiratory problems.



## Test Run

Once assembly is complete and adjustments are done to your satisfaction, you are ready to test run the machine.

Turn on the power supply at the main panel. Turn the dust collector *ON*. Make sure that your finger is poised on the toggle switch, just in case there is a problem shut-off will be quick. The dust collector should run smoothly, with little or no vibration or rubbing noises. Strange or unnatural noises should be investigated and corrected before operating the machine further.

If you cannot easily locate the source of an unusual noise or vibration, contact our service department for help.



## General

Operating your Model G0583 is simple and straightforward. Move the dust collector to the machine location, connect the duct, connect the ducting ground, and you are ready to begin.

### **! CAUTION**

**DO NOT** use the dust collector for any other purpose besides collecting dust from connected woodworking machines. A dust collector should **NEVER** be used as an air cleaner. For safest use, wear a respirator and use an air cleaner in addition to the dust collector.



# SECTION 6: MAINTENANCE

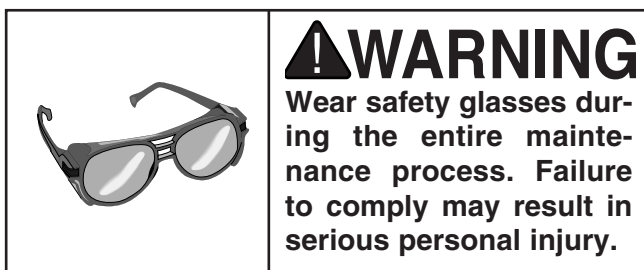
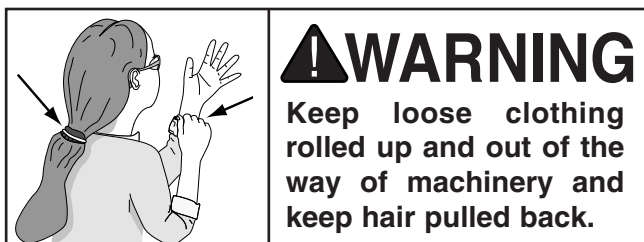
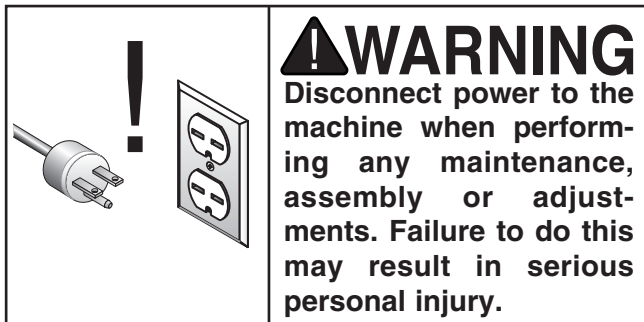

## Schedule

Regular periodic maintenance on your Model G0583 Canister Dust Collector will ensure its optimum performance. Make a habit of inspecting your machine each time you use it. Check for the following conditions and repair or replace when necessary:

1. Loose mounting bolts.
2. Worn switch.
3. Worn or damaged cords and plugs.
4. Any other condition that could hamper the safe operation of this machine.
5. Do not let collection bags get completely full.



## Lubrication

Since all bearings are shielded and permanently lubricated, simply leave them alone until they need to be replaced. Do not lubricate them.



## Bag and Canister Cleaning

Always wear a respirator or dust mask and safety glasses when emptying the storage bag (**Figure 16**). The safest option is to seal and discard the entire bag and its contents. Small dust particles can escape the bags during emptying, causing them to become airborne and easily inhaled. This microscopic airborne dust is extremely unhealthy to breathe and can cause serious health problems.

Grizzly offers replacement plastic collection bags (Part Number H2290) and canister filters for your Model G0583 Canister Dust Collector.

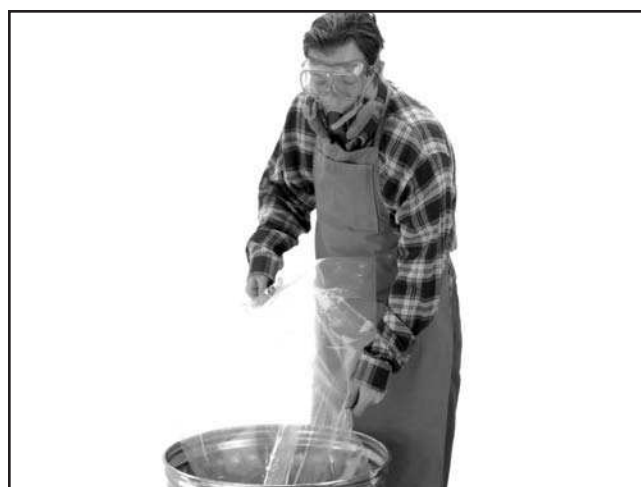

**Figure 16.** Safely disposing of wood dust.

### To clean the canister filter:

1. Rotate the canister handle 360° in both direction to vibrate the pleated canister element and free trapped dust particles from the filter (**Figure 17**). The particles will fall into the collection bag.



**Figure 17.** Rotate canister handle 360° back and forth.

### To empty the collection bag:

1. Make sure you are wearing a respirator and the canister dust collector is unplugged.
2. When the collection bag is full, un-clamp the collection bag and empty it, or tie it off and dispose of it altogether.
3. Reinstall or replace the collection bag.

While the Model G0583 excels at collecting the majority of wood dust produced by your machines, it is not an air filter; therefore, **we strongly recommend** the supplemental aid of a shop air filter such as the Grizzly G5955 or G9956. Air filters are designed to collect the smaller dust particles that a canister style dust collector cannot trap.





# Troubleshooting

SYMPTOM	POSSIBLE CAUSE	CORRECTIVE ACTION
Motor will not start, or it growls on start up.	<ol style="list-style-type: none"> <li>1. Power supply fuse or circuit breaker has tripped.</li> <li>2. Toggle switch is broken inside.</li> <li>3. Start capacitor is at fault.</li> <li>4. Motor fan cover is dented, stopping the fan from being able to spin.</li> <li>5. Motor is at fault.</li> </ol>	<ol style="list-style-type: none"> <li>1. Disconnect power, and inspect circuit for electrical shorts and repair. Replace circuit breaker if it is old or has tripped many times.</li> <li>2. Disconnect power, and use an ohmmeter to check switch terminals for continuity, and replace switch if required.</li> <li>3. Replace start capacitor.</li> <li>4. Replace motor fan cover (and fan, if damaged).</li> <li>5. Replace motor.</li> </ol>
Motor runs slower than normal.	<ol style="list-style-type: none"> <li>1. Poor electrical connection.</li> <li>2. Low power source voltage.</li> <li>3. Motor is at fault.</li> </ol>	<ol style="list-style-type: none"> <li>1. Inspect the power supply for loose, corroded, or overheated electrical connections and repair.</li> <li>2. Have the power source voltage checked; reduce the length of extension cord.</li> <li>3. Replace the motor.</li> </ol>
Loud, repetitious noise, or excessive vibration coming from dust collector.	<ol style="list-style-type: none"> <li>1. Dust collector is not on a flat surface and wobbles.</li> <li>2. Impeller fan is damaged and unbalanced.</li> <li>3. The motor mounting is loose.</li> <li>4. Impeller is loose on the motor shaft.</li> <li>5. Motor fan cover is dented, causing the motor fan to hit the cover while spinning.</li> </ol>	<ol style="list-style-type: none"> <li>1. Stabilize the dust collector.</li> <li>2. Unplug dust collector, and inspect the impeller for dents, bends, loose fins. Replace impeller if any damage is found.</li> <li>3. Make sure all fasteners on the dust collector are tight.</li> <li>4. Replace the motor and impeller as a set if the motor shaft and the impeller hub is damaged.</li> <li>5. Replace motor fan cover.</li> </ol>
Dust collector does not adequately collect dust or chips; poor performance.	<ol style="list-style-type: none"> <li>1. Dust collection bag is full.</li> <li>2. There is a restriction at the inlet grate.</li> <li>3. The dust collector is too far away from the point of suction, or there are too many sharp bends in the ducting.</li> <li>4. The lumber is wet and not flowing through the dust lines smoothly.</li> <li>5. There is a leak in the ducting, or a series of small leaks, or too many open ports.</li> <li>6. There is a restriction in the ducting, or the ducting and ports are incorrectly sized.</li> <li>7. The machine dust collection design is inadequate.</li> <li>8. The dust collector is too small for the dust collection system.</li> </ol>	<ol style="list-style-type: none"> <li>1. Empty bags.</li> <li>2. Remove dust line from dust collector inlet and clean debris from the inlet grate (and wire-connector, if installed).</li> <li>3. Relocate the dust collector closer to the point of suction, and rework ducting without sharp bends. Refer to the <i>Dust Collection Basics</i> handbook (ISBN 0-9635821-2-7) to help configure your dust system.</li> <li>4. Process lumber with less than 20% moisture content.</li> <li>5. Rework the ducting as to eliminate all leaks, and refer to the <i>Dust Collection Basics</i> handbook (ISBN 0-9635821-2-7) for more solutions.</li> <li>6. Rework the ducting as to eliminate all restrictions, and refer to the <i>Dust Collection Basics</i> handbook (ISBN 0-9635821-2-7) for more solutions.</li> <li>7. Ask your dealer for proper dust collection accessories or the <b>SHOP FOX®</b> Dust Collection Nozzle on Stand.</li> <li>8. Install a larger dust collector to power your dust collection system.</li> </ol>

# G0583 Parts Breakdown

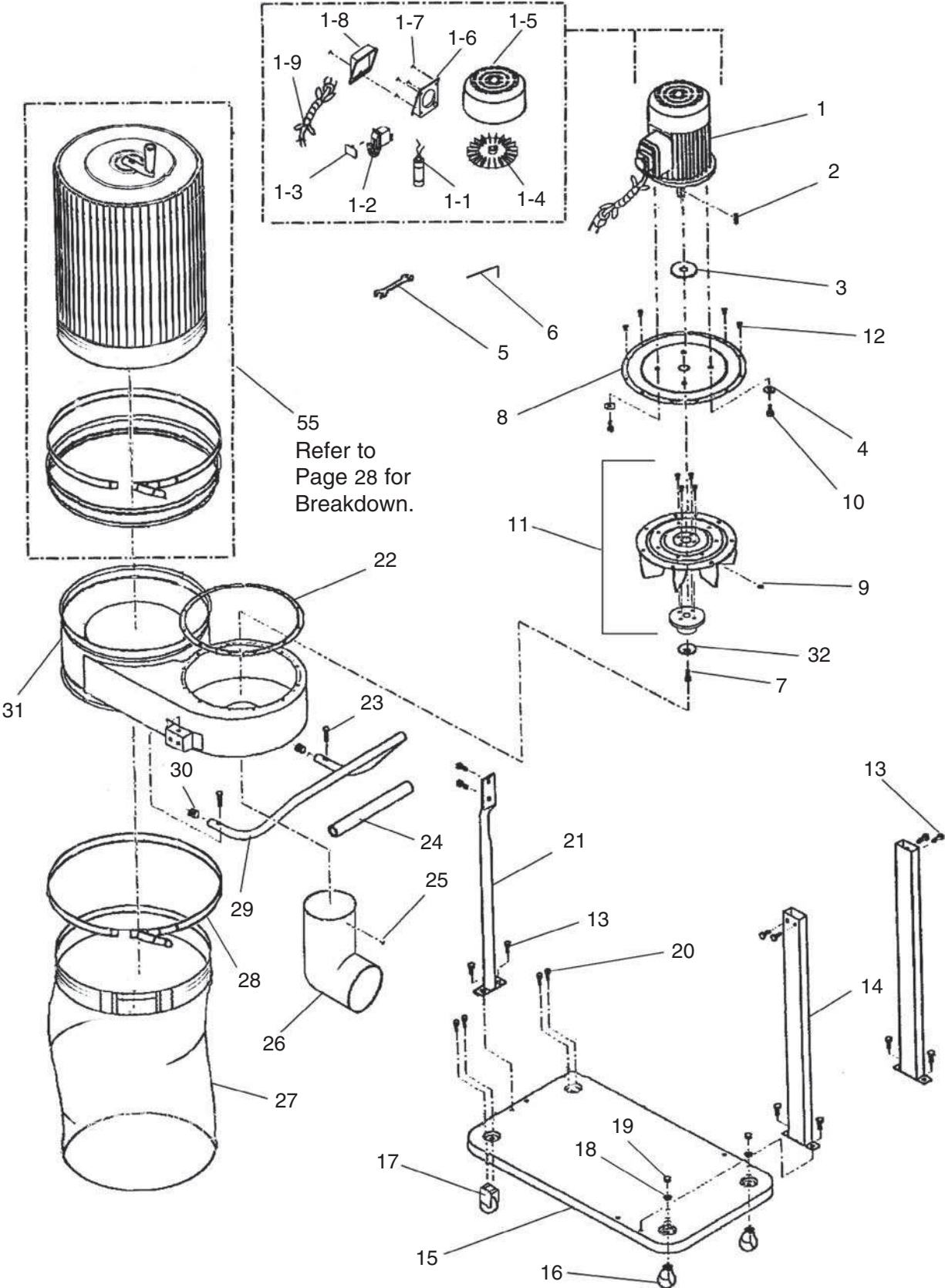

# Canister Breakdown

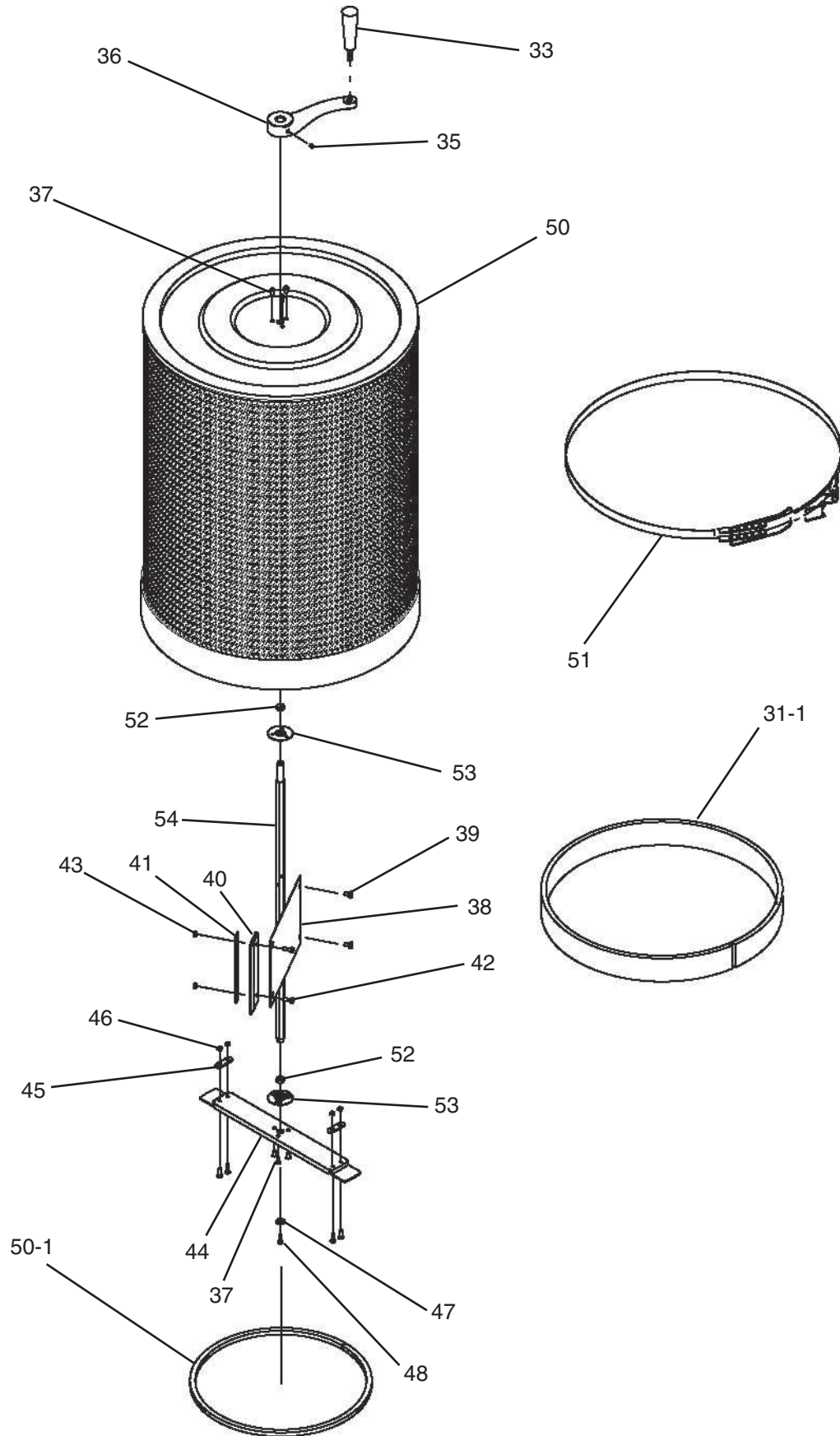

# Parts List

REF	PART #	DESCRIPTION
1	P0583001	1 HP MOTOR
1-1	PC035	S. CAPACITOR 35MFD/300V
1-2	PSW09	SWITCH
1-3	PSW09-1	SWITCH KEY
1-4	P0583031-4	FAN
1-5	P0583031-5	FAN COVER
1-6	P0583031-6	SWITCH HOUSING
1-7	PFS03	FLANGE SCR 10-24 X 3/8"
1-8	P0583031-8	SWITCH COVER
1-9	P0583031-9	POWER CORD
2	PK01M	KEY 5 X 5 X 22MM
3	P0583003	SHAFT SEAL
4	PW06	FLAT WASHER 1/4"
5	PWR1012	WRENCH 10-12MM
6	PAW05M	5MM HEX WRENCH
7	PSB02M	CAP SCREW M6-1.0 X 20
8	P0583008	INLET COVER
9	PSS17	SET SCREW 5/16"-18 X 5/16"
10	PB19	HEX BOLT 1/4"-20 X 1/2"
11	P0583011	IMPELLER/HUB ASSEMBLY
12	PS09M	PHLP HD SCR M5-0.8 X 10
13	PB09	HEX BOLT 5/16"-18 X 1/2"
14	P0583014	RECTANGLE SUPPORT LEG
15	P0583015	BASE
16	P0583016	SWIVEL CASTER
17	P0583017	FIXED CASTER
18	PW07	FLAT WASHER 5/16"
19	PN40	ACORN NUT 5/16"-18
20	PB04M	HEX BOLT M6-1.0 X 10
21	P0583021	ROUND SUPPORT LEG
22	P0583022	FOAM GASKET
23	PFH25	FLAT HD SCR 5/16"-18 X 1"

REF	PART #	DESCRIPTION
24	P0583024	FOAM HAND GRIP
25	PFS03	FLANGE SCR 10-24 X 3/8"
26	P0583026	4" ELBOW
27	H7290	DUST STORAGE BAG
28	P0583028	LOWER BAG CLAMP
29	P0583029	HAND RAIL
30	P0583030	PLASTIC CAP 5/8"
31	P0583031	IMPELLER HOUSING
31-1	P0583031-1	FOAM STRP 5 X 42MM
32	P0583032	6MM CONCAVE WASHER
33	P0583033	HANDLE
35	PSS01M	SET SCREW M6-1.0 X 10
36	P0583036	HANDLE
37	PS09M	PHLP HD SCR M5-.8 X 10
38	P0583038	FLAP BOARD
39	PB04M	HEX BOLT M6-1 X 10
40	P0583040	RUBBER FLAP
41	P0583041	FLAP PLATE
42	PS20M	PHLP HD SCR M5-.8 X 15
43	PLN02M	LOCK NUT M5-.8
44	P0583044	BOTTOM PLATE
45	P0583045	SUPPORT TAB
46	PN06M	HEX NUT M5-.8
47	PW06	FLAT WASHER 1/4"
48	PS68M	PHLP HD SCR M6-1 X 10
50	P0583050	FILTER
50-1	P0583050-1	FOAM GASKET 10 X 15 MM
51	P0583051	CANISTER BAND CLAMP
52	P0583052	THREAD BEARING
53	P0583053	BEARING PLATE
54	P0583054	HEX SPINDLE
55	P0583055	COMPLETE CANISTER ASSY

# Accessories

## H2797—SHOP FOX® Remote Dust Collector Switch.

This remote switch turns your dust collector on and off from anywhere in your shop up to 75 feet away, saving you trips to your collector whenever you operate a shop machine. Includes two controls with 9V batteries. Use H2797 on 110V dust collectors up to 1 1/2 HP. Use H5397 on 220V dust collectors up to 3 HP.



## G3181—Dust Collection Kit #1

Designed for a one machine hook-up, kit #1 comes complete with installation instructions and an accessories list for expanding your dust collection system in the future. Accessories included:

- (1) G1536 4" x 10' Hose
- (1) G1838 Universal Dust Hood
- (2) G2974 Wire Hose Clamps



G0583 1 HP Canister Dust Collector

## G4679—Grounding Kit

Eliminate potential hazards by dissipating static charges. Kit includes 50' of 14-gauge bare copper wire, electrical connectors, grounding screws, terminal ends and instructions.



## G2525—Dust Collection Basics

This incisive book skillfully guides the woodworker through all the steps necessary in the design and construction of an efficient central dust collection system and tells you what you need to know for easy installation. The text offers practical hints and techniques and takes the mystery, misery and hype away from a subject that should be as clear as the air you breathe. Fifty pages of concise, carefully illustrated text. A MUST!

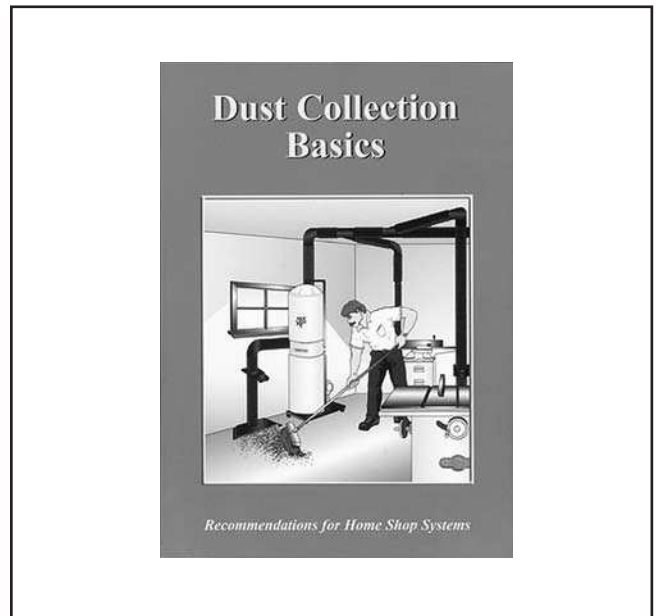

# Notes

# Notes

# WARRANTY AND RETURNS

---

---

Grizzly Industrial, Inc. warrants every product it sells for a period of **1 year** to the original purchaser from the date of purchase. This warranty does not apply to defects due directly or indirectly to misuse, abuse, negligence, accidents, repairs or alterations or lack of maintenance. This is Grizzly's sole written warranty and any and all warranties that may be implied by law, including any merchantability or fitness, for any particular purpose, are hereby limited to the duration of this written warranty. We do not warrant or represent that the merchandise complies with the provisions of any law or acts unless the manufacturer so warrants. In no event shall Grizzly's liability under this warranty exceed the purchase price paid for the product and any legal actions brought against Grizzly shall be tried in the State of Washington, County of Whatcom.

We shall in no event be liable for death, injuries to persons or property or for incidental, contingent, special, or consequential damages arising from the use of our products.

To take advantage of this warranty, contact us by mail or phone and give us all the details. We will then issue you a "Return Number," which must be clearly posted on the outside as well as the inside of the carton. We will not accept any item back without this number. Proof of purchase must accompany the merchandise.

The manufacturers reserve the right to change specifications at any time because they constantly strive to achieve better quality equipment. We make every effort to ensure that our products meet high quality and durability standards and we hope you never need to use this warranty.

Please feel free to write or call us if you have any questions about the machine or the manual.

Thank you again for your business and continued support. We hope to serve you again soon.



**Grizzly** WARRANTY CARD  
Industrial, Inc.

Name \_\_\_\_\_  
 Street \_\_\_\_\_  
 City \_\_\_\_\_ State \_\_\_\_\_ Zip \_\_\_\_\_  
 Phone # \_\_\_\_\_ Email \_\_\_\_\_ Invoice # \_\_\_\_\_  
 Model # \_\_\_\_\_ Order # \_\_\_\_\_ Serial # \_\_\_\_\_

The following information is given on a voluntary basis. It will be used for marketing purposes to help us develop better products and services. **Of course, all information is strictly confidential.**

1. How did you learn about us?  
 Advertisement       Friend       Catalog  
 Card Deck       Website       Other:

2. Which of the following magazines do you subscribe to?

<input type="checkbox"/> Cabinet Maker	<input type="checkbox"/> Popular Mechanics	<input type="checkbox"/> Today's Homeowner
<input type="checkbox"/> Family Handyman	<input type="checkbox"/> Popular Science	<input type="checkbox"/> Wood
<input type="checkbox"/> Hand Loader	<input type="checkbox"/> Popular Woodworking	<input type="checkbox"/> Wooden Boat
<input type="checkbox"/> Handy	<input type="checkbox"/> Practical Homeowner	<input type="checkbox"/> Woodshop News
<input type="checkbox"/> Home Shop Machinist	<input type="checkbox"/> Precision Shooter	<input type="checkbox"/> Woodsmith
<input type="checkbox"/> Journal of Light Cont.	<input type="checkbox"/> Projects in Metal	<input type="checkbox"/> Woodwork
<input type="checkbox"/> Live Steam	<input type="checkbox"/> RC Modeler	<input type="checkbox"/> Woodworker West
<input type="checkbox"/> Model Airplane News	<input type="checkbox"/> Rifle	<input type="checkbox"/> Woodworker's Journal
<input type="checkbox"/> Modeltec	<input type="checkbox"/> Shop Notes	<input type="checkbox"/> Other:
<input type="checkbox"/> Old House Journal	<input type="checkbox"/> Shotgun News	

CUT ALONG DOTTED LINE

3. What is your annual household income?  
 \$20,000-\$29,000       \$30,000-\$39,000       \$40,000-\$49,000  
 \$50,000-\$59,000       \$60,000-\$69,000       \$70,000+

4. What is your age group?  
 20-29       30-39       40-49  
 50-59       60-69       70+

5. How long have you been a woodworker/metalworker?  
 0-2 Years       2-8 Years       8-20 Years       20+ Years

6. How many of your machines or tools are Grizzly?  
 0-2       3-5       6-9       10+

7. Do you think your machine represents a good value?       Yes       No

8. Would you recommend Grizzly Industrial to a friend?       Yes       No

9. Would you allow us to use your name as a reference for Grizzly customers in your area?  
 Note: We never use names more than 3 times.       Yes       No

10. Comments: \_\_\_\_\_  
 \_\_\_\_\_  
 \_\_\_\_\_  
 \_\_\_\_\_

FOLD ALONG DOTTED LINE

\_\_\_\_\_  
\_\_\_\_\_  
\_\_\_\_\_



Place  
Stamp  
Here



**GRIZZLY INDUSTRIAL, INC.**  
**P.O. BOX 2069**  
**BELLINGHAM, WA 98227-2069**



FOLD ALONG DOTTED LINE

Send a Grizzly Catalog to a friend:

Name \_\_\_\_\_  
Street \_\_\_\_\_  
City \_\_\_\_\_ State \_\_\_\_\_ Zip \_\_\_\_\_

TAPE ALONG EDGES--PLEASE DO NOT STAPLE



# *grizzly.com*

**TOOL WEBSITE**

Buy Direct and Save with Grizzly® – Trusted, Proven and a Great Value!

*Visit Our Website Today And Discover Why  
Grizzly® Is The Industry Leader!*

- SECURE ORDERING
- ORDERS SHIPPED WITHIN 24 HOURS
- E-MAIL RESPONSE WITHIN ONE HOUR

-OR-

Call Today For A **FREE**

Full Color Catalog

**1-800-523-4777**

