

READ THIS FIRST



**Models G0445, G0582,
G9962Z, & G9962ZX
IMPORTANT UPDATE**

**For Machines Mfd. Since January, 2014
and Owner's Manual Revised June, 2006**

For questions or help with this product contact Tech Support at (570) 546-9663 or techsupport@grizzly.com

The following changes were recently made to this machine since the owner's manual was printed:

- Obtained CSA certification meeting CSA C22.2 #105-1953 and UL 987-7th standards.
- Changed electrical system, including a new transformer, overload relay, terminal blocks, and wiring.
- Changed circuit requirements.
- Replaced oscillation diaphragm assembly with an air cylinder.

Note: At the top of each page is a note that indicates which page it replaces in the original manual. On the parts list, the new parts are designated with a "V2".

Aside from this information, all other content in the owner's manual applies and **MUST** be read and understood for your own safety. **IMPORTANT: Keep this update with the owner's manual for future reference.** For questions or help, contact our Tech Support at (570) 546-9663 or techsupport@grizzly.com.

Electrical Parts List (Replaces Page 67)

REF	PART #	DESCRIPTION
8101	P9962Z8101	ELECTRICAL CONTROL BOX
8102	P9962Z8102	HINGE
8103	P9962Z8103	CONTROL BOX DOOR
8104	P9962Z8104	BASE PLATE
8105	PN05	HEX NUT 1/4-20
8106	PLW02	LOCK WASHER 1/4
8107	P9962Z8107	CONTROL PANEL
8108	PS07M	PHLP HD SCR M4-0.7 X 8
8109	P9962Z8109	AMP SENSOR (G9962Z)
8109	P9962ZX8109	AMP SENSOR (G0445/G9962ZX/G0582)
8110V2	P9962ZX8110V2	TRANSFORMER V2.03.10 (G0445/G9962ZX/G0582)
8111V2	P9962Z8111V2	CONTACTOR TELE LC1D50A 220V V2.11.10 (G9962Z)
8111	P9962ZX8111	CONTACTOR TELE LC1D386 220V (G0445/G9962ZX/G0582)
8112	P9962ZX8112	OL RELAY TELE LR3D326 23-32A (G0445/G9962ZX/G0582)
8113V2	P9962Z8113V2	FUSE HOUSING V2.03.10
8113V2-1	P9962Z8113V2-1	FUSE 4 AMP V2.03.10
8114	P9962Z8114	OL RELAY TELE LR3D126 5.5-8A (G9962Z)

440V CONVERSION PARTS

8135	P9962ZX8135	OL RELAY TELE LR3D216 12-18A (G0445/G9962ZX/G0582)
8136	P9962ZX8136	OL RELAY TELE LR3D076 1.6-2.5A (G0445/G9962ZX/G0582)

REF	PART #	DESCRIPTION
8114	P9962ZX8114	OL RELAY TELE LR3D086 2.5-4A (G0445/G9962ZX/G0582)
8115	P9962Z8115	CONTACTOR TELE LC1D096 220V
8115-1	P9962Z8115-1	CONTACTOR 2-PC ASSY LC1D096
8116V2	P9962Z8116V2	POWER TERMINAL BLOCK V2.03.10 (G9962Z)
8116V2	P9962ZX8116V2	POWER TERMINAL BLOCK V2.03.10 (G0445/G0582/G9962ZX)
8117	PS52M	PHLP HD SCR M4-0.7 X 30
8118V2	P9962Z8118V2	TERMINAL BLOCK V2.03.10 (G9962Z)
8118V2	P9962ZX8118V2	TERMINAL BLOCK V2.03.10 (G0445/G0582/G9962ZX)
8119	PW06	FLAT WASHER 1/4
8120	PLW02	LOCK WASHER 1/4
8121	PB26	HEX BOLT 1/4-20 X 1/2
8122	P9962Z8122	PU CONNECTOR 1/2
8123	P9962Z8123	PU CONNECTOR 3/4
8124	P9962Z8124	CABLE CONNECTOR 1
8126A	PH29338126A	DIGITAL AMP METER N/S
8128-1	P9962Z8128-1	START SWITCH
8128-2	P9962Z8128-2	START SWITCH
8129-1	P9962Z8129-1	STOP SWITCH
8129-2	P9962Z8129-2	STOP SWITCH
8130	P9962Z8130	POWER INDICATION LIGHT
8131	P9962Z8131	EMERGENCY STOP SWITCH
8132	P9962Z8132	WIRE COLUMN
8133	P9962Z8133	CPU
8134	P9983627	OL RELAY TELE LT47 5-60A (G9962Z)



COPYRIGHT © APRIL, 2014 BY GRIZZLY INDUSTRIAL, INC.
**WARNING: NO PORTION OF THIS MANUAL MAY BE REPRODUCED IN ANY SHAPE
OR FORM WITHOUT THE WRITTEN APPROVAL OF GRIZZLY INDUSTRIAL, INC.**

#TS16504 PRINTED IN TAIWAN

Replaces Page 66

Main Electrical Panel and Controls Diagram

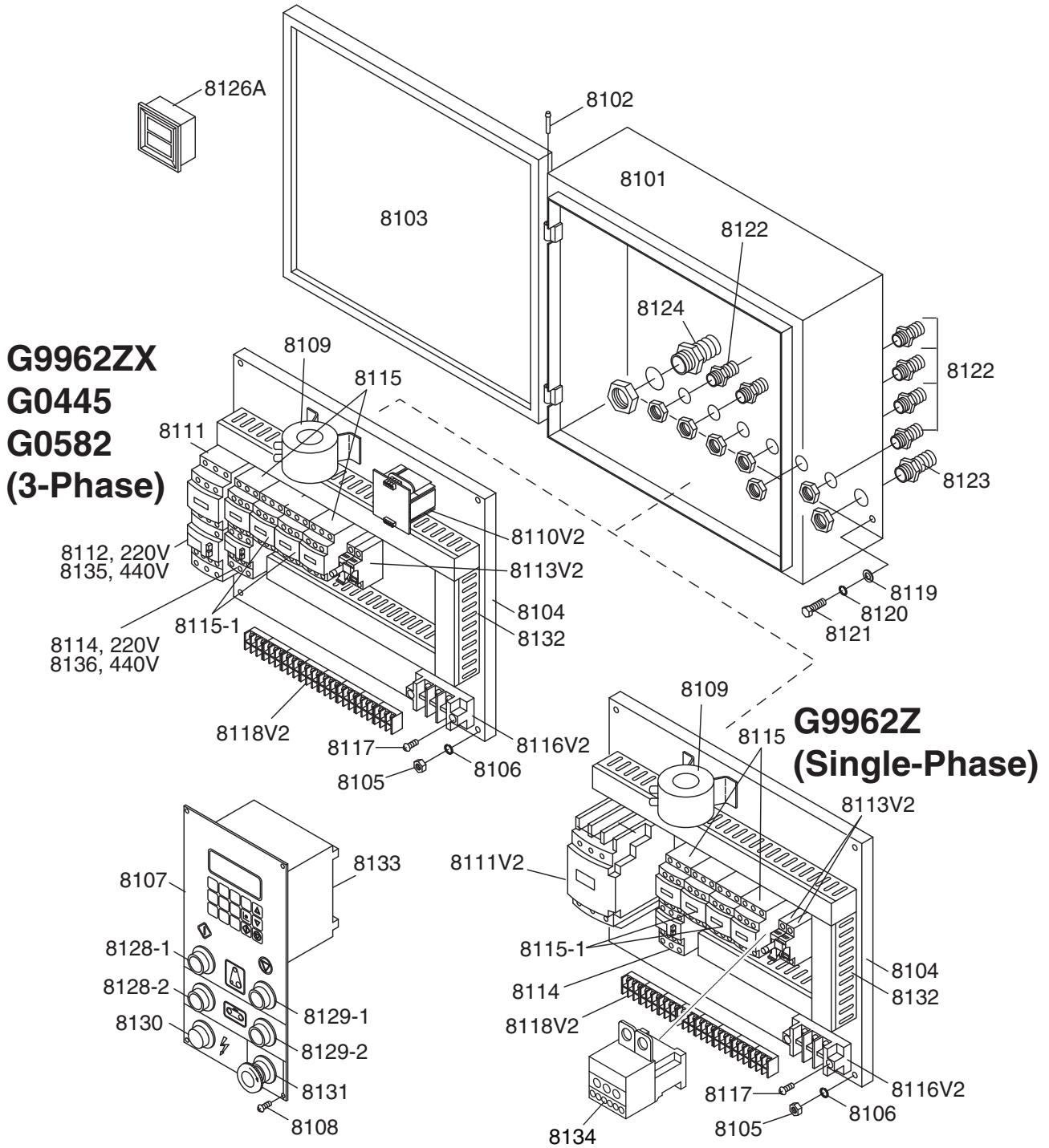

**G9962ZX
G0445
G0582
(3-Phase)**

**G9962Z
(Single-Phase)**



Replaces Page 62

Upper Roller System Diagram

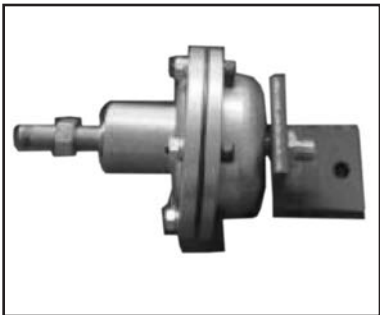
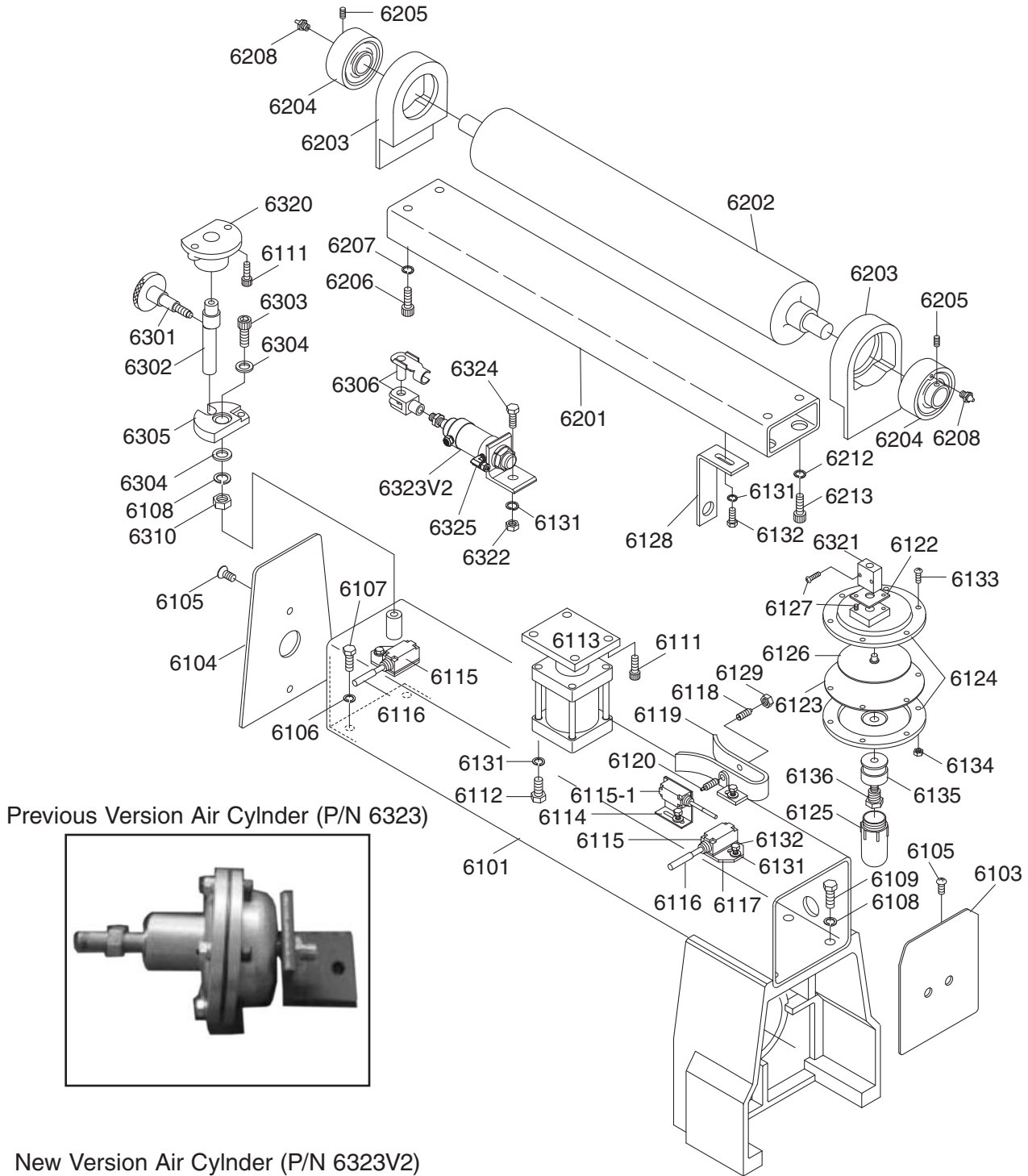

Replaces Page 63

Upper Roller System Parts List

REF	PART #	DESCRIPTION
6101	P04456101	SQUARE FRAME (G0445)
6101	P9962Z6101	SQUARE FRAME (G9962Z/G9962ZX/G0582)
6103	P04456103	FRAME SEAL (RIGHT) (G0445)
6103	P9962Z6103	FRAME SEAL (RIGHT) (G9962Z/G9962ZX/G0582)
6104	P04456104	FRAME SEAL (LEFT) (G0445)
6104	P9962Z6104	FRAME SEAL (LEFT) (G9962Z/G9962ZX/G0582)
6105	PFH05	FLAT HD SCR 1/4-20 X 3/4
6106	PLW04	LOCK WASHER 3/8
6107	PB18	HEX BOLT 3/8-16 X 1
6108	PLW07	LOCK WASHER 1/2
6109	PCAP78	CAP SCREW 1/2-12 X 1
6111	PCAP07	CAP SCREW 5/16-18 X 3/4
6112	PB09M	HEX BOLT M8-1.25 X 20
6113	P9962Z6113	AIR CYLINDER
6114	P9962Z6114	LIMIT SWITCH HOLDER (L TYPE)
6115	P9962Z6115	LIMIT SWITCH
6115-1	P9962Z6115-1	LIMIT SWITCH
6116	P9962Z6116	LIMIT SWITCH POST
6117	P9962Z6117	LIMIT SWITCH HOLDER
6118	P9962Z6118	AIR SENSOR NOZZLE (FEMALE)
6119	P9962Z6119	AIR CYLINDER BRACKET
6120	P9962Z6120	AIR SENSOR NOZZLE (MALE)
6122	P9962Z6122	THROTTLE VALVE BASE
6123	P9962Z6123	PLATE
6124	P9962Z6124	ALUMINUM DISC
6125	P9962Z6125	OIL CAP
6126	P9962Z6126	ALUMINUM PLATE
6127	PS52M	PHLP HD SCR M4-0.7 X 20

REF	PART #	DESCRIPTION
6128	P9962Z6128	BRACKET
6129	PN11	HEX NUT 3/8-24 (FINE THREAD)
6131	PLW01	LOCK WASHER 5/16
6132	PB07	HEX BOLT 5/16-18 X 3/4
6133	PS08	PHLP HD SCR #10-24 X 3/4
6134	PN07	HEX NUT #10-24
6135	P9962Z6135	OIL CAP CONNECTOR
6136	P9962Z6136	OIL CAP SHAFT
6201	P9962Z6201	UPPER ROLLER BRACKET
6202	P9962Z6202	UPPER ROLLER
6203	P9962Z6203	UPPER ROLLER BRACKET
6204	P9962Z6204	BEARING UCC205
6205	PSS02M	SET SCREW M6-1.0 X 6
6206	PCAP16	CAP SCREW 3/8-16 X 3/4
6207	PLW04	LOCK WASHER 3/8
6208	P9962Z6208	FILTER
6212	PLW04	LOCK WASHER 3/8
6213	PCAP16	CAP SCREW 3/8-16 X 3/4
6301	P9962Z6301	TRIMMING ADJUSTER
6302	P9962Z6302	ECCENTRIC ROD
6303	PCAP79	CAP SCREW 1/2-12 X 3-1/2
6304	PW01	FLAT WASHER 1/2
6305	P9962Z6305	ECCENTRIC PIECE
6306	P9962Z6306	UNIVERSAL JOINT FORK
6310	PN13	HEX NUT 1/2-13
6320	P9962Z6320	ECCENTRIC SHAFT COLLAR
6321	P9962Z6321	VALVE ASSEMBLY
6322	PN02	HEX NUT 5/16-18
6323V2	P9962Z6323V2	OSCILLATION AIR CYLINDER V2.01.14
6324	PB11	HEX BOLT 5/16-18 X 1-1/2
6325	P9962Z9124	CONNECTOR 1/4N X 1/8T X 90°



Replaces Page 68

Belt Oscillation System Diagram

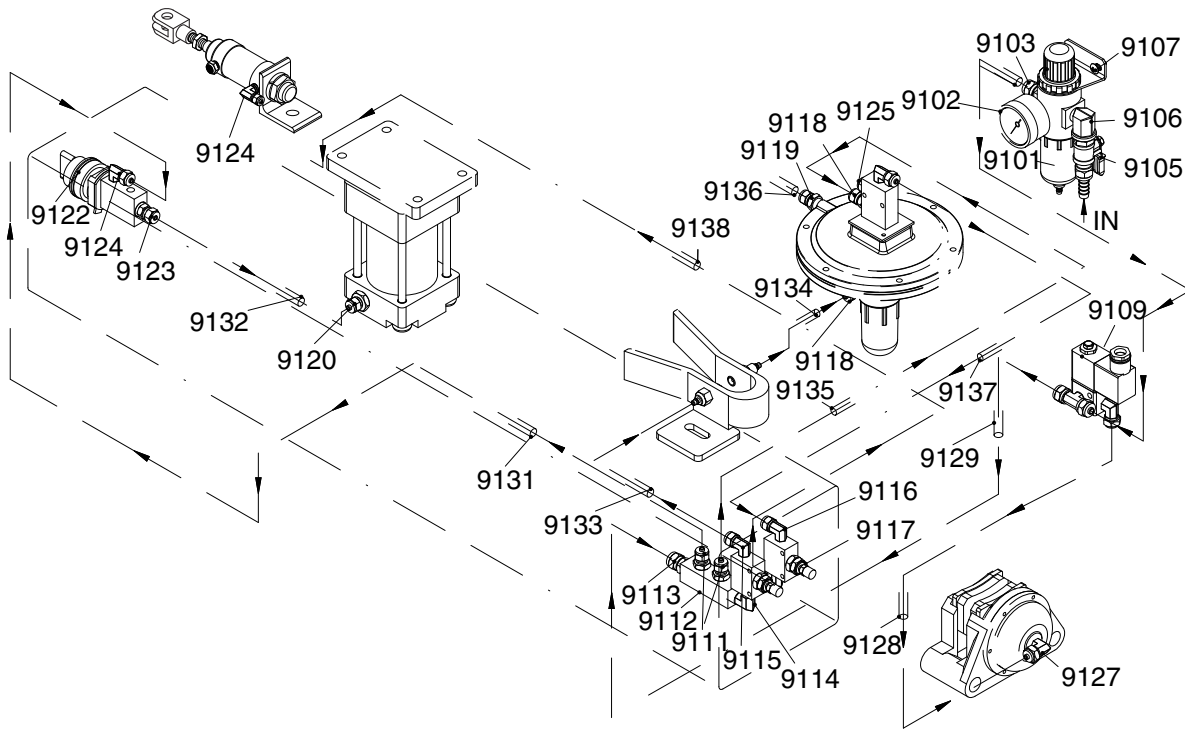

REF	PART #	DESCRIPTION
9101	P9962Z9101	FILTER CUP
9102	P9962Z9102	PRESSURE REGULATOR
9103	P9962Z9103	CONNECTOR, BRONZE
9105	P9962Z9105	AIR SWITCH
9106	P9962Z9106	ELBOW
9107	PS01	PHLP HD SCR 10-24 X 1/2
9109	P9962Z9109	SOLENOID VALVE
9111	P9962Z9111	CONNECTOR, BRONZE
9112	P9962Z9112	AIR MANIFOLD
9113	P9962Z9113	CONNECTOR, BRONZE
9114	P9962Z9114	ELBOW 1/4N X 1/8T X 90°, BRONZE
9115	P9962Z9115	CONNECTOR 1/4N X 1/8T X 90°
9116	P9962Z9116	CONNECTOR 1/4N X 1/8T X 90°
9117	P9962Z9117	THROTTLE VALVE
9118	P9962Z9118	CONNECTOR, BRONZE
9119	P9962Z9119	ELBOW, BRONZE

REF	PART #	DESCRIPTION
9120	P9962Z9120	CONNECTOR 1/4N X 3/8T
9122	P9962Z9122	AIR SWITCH
9123	P9962Z9123	CONNECTOR 1/4N X 1/8T
9124	P9962Z9124	CONNECTOR 1/4N X 1/8T X 90°
9125	P9962Z9125	BUFFER
9127	P9962Z9127	CONNECTOR 5/16N X 1/8T X 90°
9128	P9962Z9128	FLEXIBLE HOSE 8MM
9129	P9962Z9129	FLEXIBLE HOSE 8MM
9131	P9962Z9131	FLEXIBLE HOSE 6MM
9132	P9962Z9132	FLEXIBLE HOSE 6MM
9133	P9962Z9133	FLEXIBLE HOSE 6MM
9134	P9962Z9134	FLEXIBLE HOSE 6MM
9135	P9962Z9135	FLEXIBLE HOSE 6MM
9136	P9962Z9136	FLEXIBLE HOSE 6MM
9137	P9962Z9137	FLEXIBLE HOSE 6MM
9138	P9962Z9138	FLEXIBLE HOSE 6MM



Tool Box and Accessories Diagram

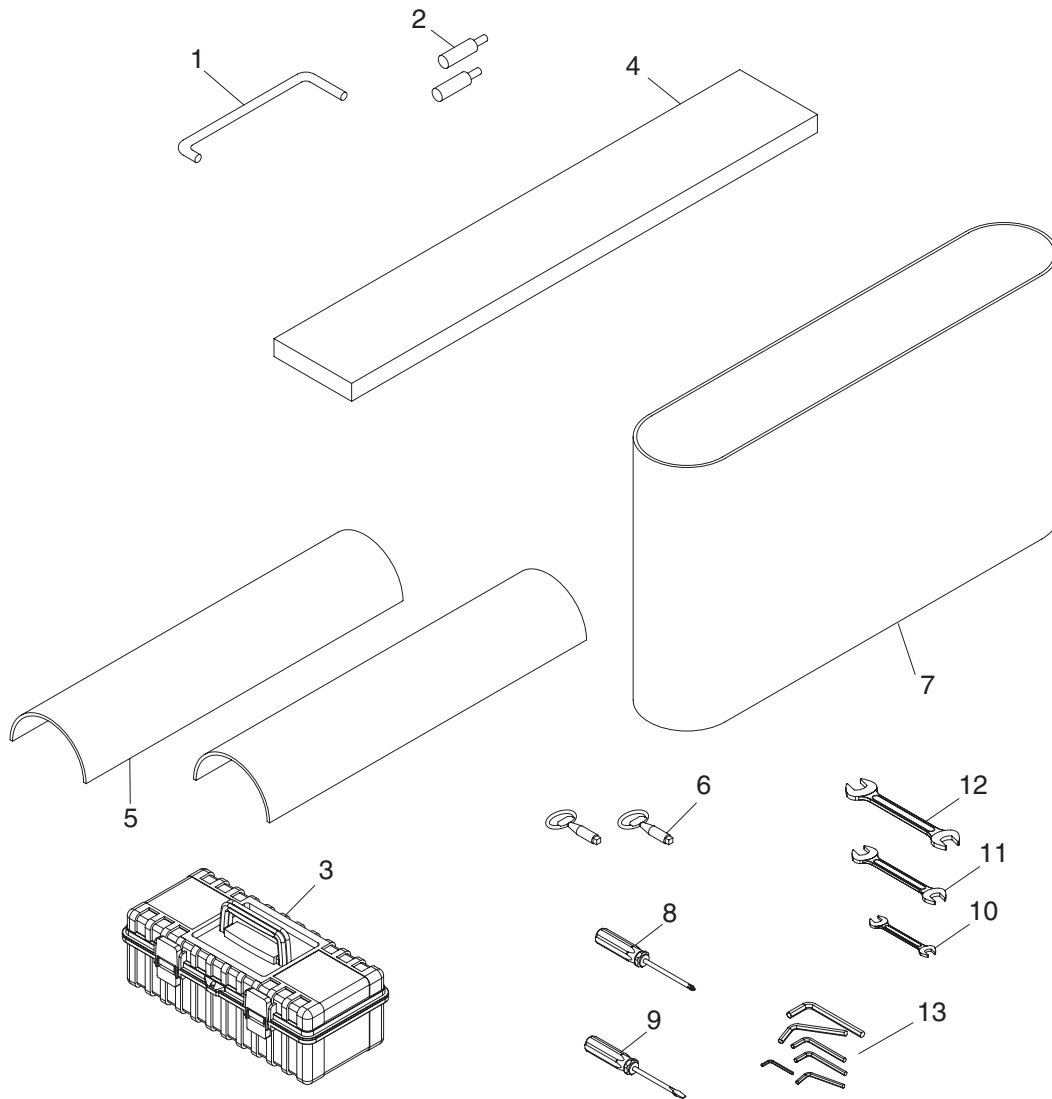

Tool Box and Accessories Parts List

REF	PART #	DESCRIPTION
1	PH29330001	PLATEN REMOVAL TOOL (G0445/G0582)
2	P9962Z0002	LIMIT SWITCH ROD
3	P9962Z0003	TOOL BOX
4	P0582004	FELT PAD (G0445/G0582)
5	P0582005	GRAPHITE PAD (G0445/G0582)
6	P9962Z0006	DOOR HANDLE
7	G8677	SANDING BELT (#100) (G9962Z/G9962ZX)
7	G8679	SANDING BELT (#150) (G9962Z/G9962ZX)

REF	PART #	DESCRIPTION
7	P0582007	SANDING BELT (#100, 75" LONG) (G0445/G0582)
7	P0582009	SANDING BELT (#180, 75" LONG) (G0445/G0582)
8	P9962Z0008	PHILLIPS SCREWDRIVER
9	P9962Z0009	FLAT SCREWDRIVER
10	PWR810	8 X 10 WRENCH
11	PWR1214	12 x 14 WRENCH
12	PWR1719	17 x 19 WRENCH
13	P9962Z0013	HEX WRENCH SET



Sanding Motor System Diagram

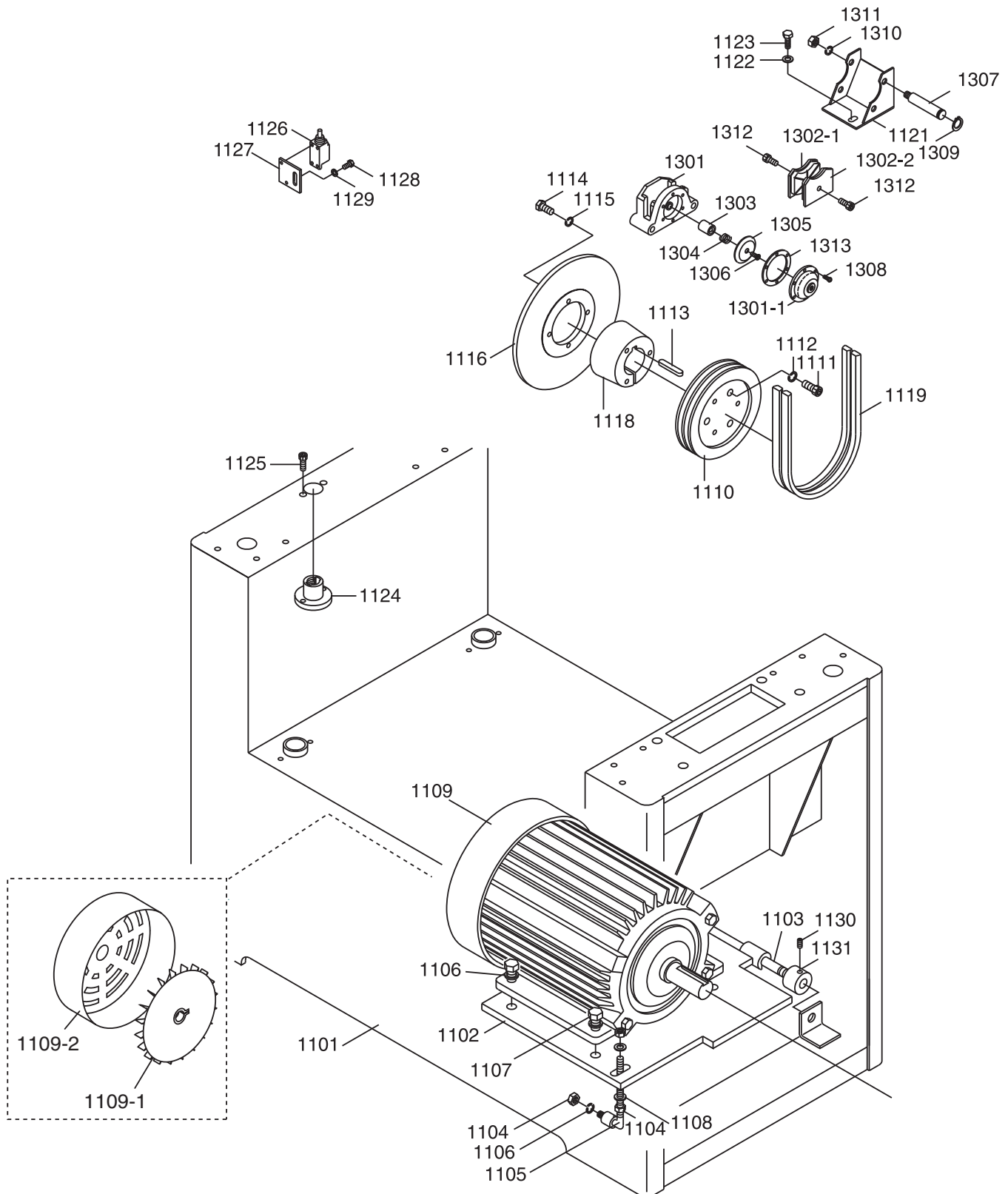

Sanding Motor System Parts List

REF	PART #	DESCRIPTION
1101	P9962Z1101	MACHINE FRAME
1102	P9962Z1102	MOTOR BASE
1103	P9962Z1103	MOTOR BASE HINGE
1104	PN13	HEX NUT 1/2-13
1105	P9962Z1105	MOTOR BASE ADJUSTMENT ROD
1106	PLW07	LOCK WASHER 1/2
1107	PB78	HEX BOLT 1/2-13 x 1-1/4
1108	PW01	FLAT WASHER 1/2
1109	P9962Z1109	10 HP MOTOR (G9962Z)
1109	P9962ZX1109	10 HP MOTOR (G9962ZX/G0582/G0445)
1109-1	P9962Z1109-1	MOTOR FAN (G9962Z)
1109-2	P9962Z1109-2	MOTOR FAN COVER (G9962Z)
1109-1	P9962ZX1109-1	MOTOR FAN (G9962ZX/G0582/G0445)
1109-2	P9962ZX1109-2	FAN COVER (G9962ZX/G0582/G0445)
1110	P9962Z1110	PULLEY (G9962Z/G9962ZX)
1110	P05821110	PULLEY (G0582/G0445)
1111	PSB11	CAP SCREW 5/16-18 x 1-1/4
1112	PLW01	LOCK WASHER 5/16
1113	P9962Z1113	KEY 10 X 8 X 75
1114	PB03	HEX BOLT 5/16-18 X 1
1115	PLW01	LOCK WASHER 5/16
1116	P9962Z1116	DISC BRAKE
1118	P9962Z1118	PULLEY BUSHING
1119	PVB77	V-BELT B-77 (G9962Z/G9962ZX)
1119	PVA71	V-BELT A-71 (G0582/G0445)

REF	PART #	DESCRIPTION
1121	P9962Z1121	BRAKE BRACKET
1122	PW02	FLAT WASHER 3/8
1123	PB21	HEX BOLT 3/8-16 x 3/4
1124	P9962Z1124	TABLE LIFTING COLLAR
1125	PSB05	CAP SCREW 1/4-20 X 3/4
1126	P9962Z1126	LIMIT SWITCH
1127	P9962Z1127	LIMIT SWITCH PLATE
1128	PB19	HEX BOLT 1/4-20 X 1/2
1129	PW06	FLAT WASHER 1/4
1130	PSS18	SET SCREW 5/16-18 X 3/4
1131	P9962Z1131	COVER OF MOTOR BASE
1132	PW02	FLAT WASHER 3/8
1301	P9962Z1301	BRAKE BRACKET
1301-1	P9962Z1301-1	BRAKE BRACKET FRONT
1302-1	P9962Z1302-1	BRAKE LINING
1302-2	P9962Z1302-2	BRAKE LINING
1303	P9962Z1303	BRAKE ARBOR
1304	P9962Z1304	BRAKE SPRING
1305	P9962Z1305	BRAKE INSIDE PIECE
1306	PFH12M	FLAT HD SCR M6-1 X 25
1307	P9962Z1307	BRAKE PIN
1308	PSB10M	CAP SCREW M5-.8 X 15
1309	PR03M	EXT RETAINING RING 12MM
1310	PLW04	LOCK WASHER 3/8
1311	PN08	HEX NUT 3/8-16
1312	PSB26M	CAP SCREW M6-1.0 X 12
1313	P9962Z1313	BRAKE GASKET



Table Lift System Diagram

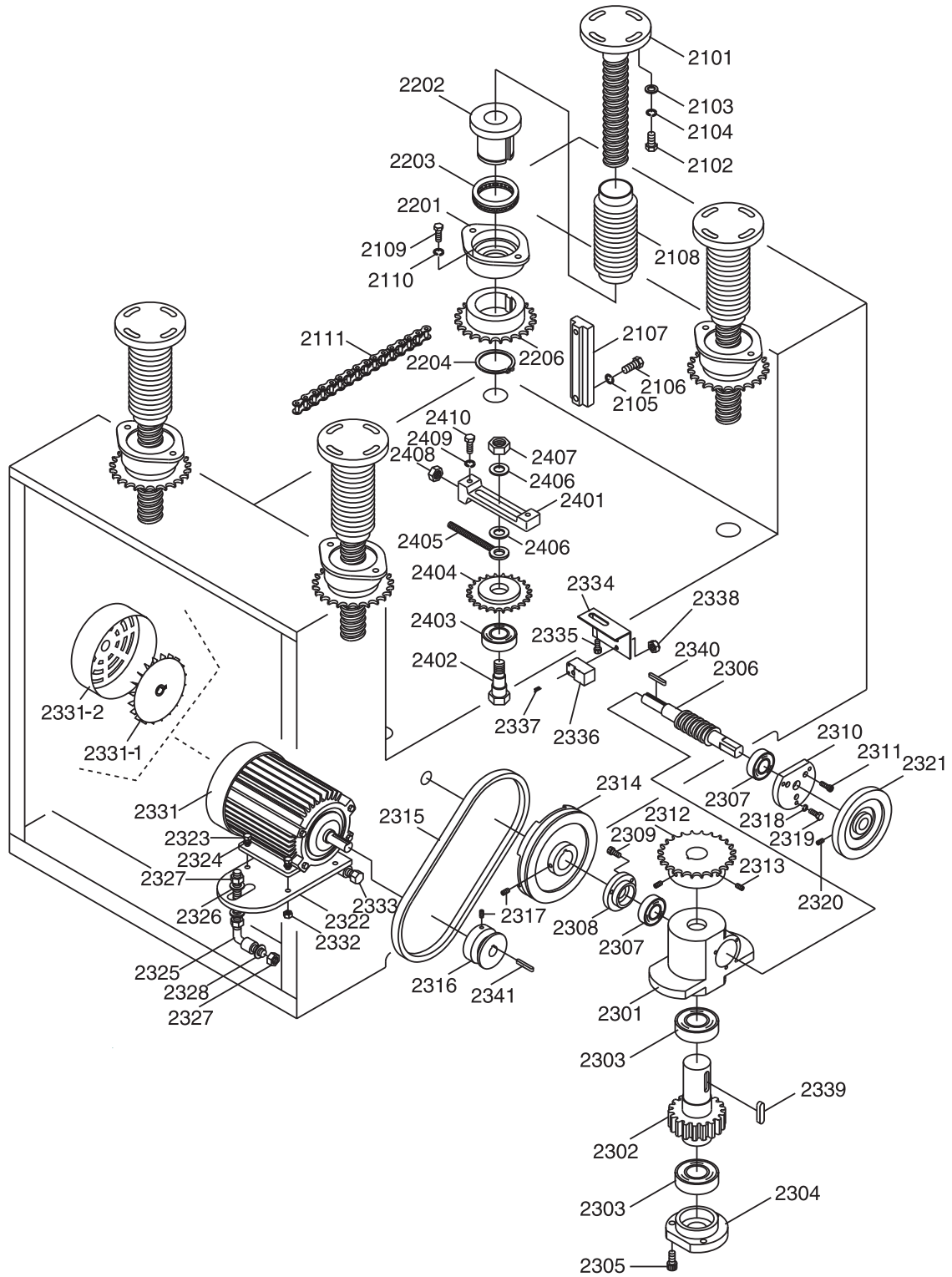

Table Lift System Parts List

REF	PART #	DESCRIPTION
2101	P9962Z2101	ELEVATION SCREW
2102	PB03	HEX BOLT 5/16-18 X 1
2103	PW07	FLAT WASHER 5/16
2104	PLW01	LOCK WASHER 5/16
2105	PLW04	LOCK WASHER 3/8
2106	PB18	HEX BOLT 3/8-16 X 1
2107	P9962Z2107	ELEVATION SLIDE
2108	P9962Z2108	DUST GUARD BELLOW
2109	PB07	HEX BOLT 5/16-18 X 3/4
2110	PLW01	LOCK WASHER 5/16
2111	P9962Z2111	CHAIN
2201	P9962Z2201	COLLAR HOUSING
2202	P9962Z2202	COLLAR
2203	P9962Z2203	THRUST BEARING 51107
2204	P9962Z2204	CLIP
2206	P9962Z2206	SPROCKET WHEEL
2301	P9962Z2301	ELEVATION GEAR BOX
2302	P9962Z2302	WORM GEAR
2303	P6005	BEARING 6005Z
2304	P9962Z2304	BEARING CAP
2305	PSB05	CAP SCREW 1/4-20 X 3/4
2306	P9962Z2306	WORM SHAFT
2307	P6002	BEARING 6002Z
2308	P9962Z2308	BEARING CAP
2309	PSB33	CAP SCREW 10-24 X 3/4
2310	P9962Z2310	BEARING CAP
2311	PSB01	CAP SCREW 1/4-20 X 5/8
2312	P9962Z2312	SPROCKET WHEEL
2313	PSS08	SETSCREW 5/16-18 X 1/2
2314	P9962Z2314	PULLEY
2315	P9962Z2315	V-BELT A36: (1-PH)
2315A	P9962Z2315A	V-BELT A37: (3-PH)
2316	P9962Z2316	PULLEY
2317	PSS07	SETSCREW 1/4-20 X 1/2
2318	PLW01	LOCK WASHER 5/16
2319	PB07	HEX BOLT 5/16-18 X 3/4
2320	PSS07	SETSCREW 1/4-20 X 1/2

REF	PART #	DESCRIPTION
2321	P9962Z2321	HANDWHEEL
2322	P9962Z2322	MOTOR BASE
2323	PB31	HEX BOLT 1/4-20 X 1
2324	PLW02	LOCK WASHER 1/4
2325	P9962Z2325	MOTOR BASE ROD
2326	PW01	FLAT WASHER 1/2
2327	PN06	HEX NUT 1/2-12
2328	PLW07	LOCK WASHER 1/2
2331	P9962Z2331	1/3 HP MOTOR (G9962Z)
2331-1	P9962Z2331-1	MOTOR FAN (G9962Z)
2331-2	P9962Z2331-2	MOTOR FAN COVER (G9962Z)
2331	P9962ZX2331	1/4 HP MOTOR (G9962ZX/G0582/G0445)
2331-1	P9962ZX2331-1	MOTOR FAN (G9962ZX/G0582/G0445)
2331-2	P9962ZX2331-2	MOTOR COVER (G9962ZX/G0582/G0445)
2332	PN05	HEX NUT 1/4-20
2333	PB89	HEX BOLT 1/2-12 X 4-1/2
2334	P9962Z2334	PROXIMITY SWITCH PLATE
2335	PB19	HEX BOLT 1/4-20 X 1/2
2336	P9962Z2336	PROXIMITY SWITCH
2337	PS55M	PHLP HD SCR M3-0.5 X 35
2338	PN07M	HEX NUT M3-0.5
2339	P9962Z2339	KEY 5/16 X 5/16 X 3/4
2340	P9962Z2340	KEY 4 X 4 X 20
2341	P9962Z2341	KEY 4 X 4 X 10
2401	P9962Z2401	SPROCKET WHEEL ADJUST PIECE
2402	P9962Z2402	SPROCKET WHEEL SHAFT
2403	P6003	BEARING 6003ZZ
2404	P9962Z2404	ADJUST SPROCKET WHEEL
2405	P9962Z2405	SPROCKET WHEEL ADJUST ROD
2406	PW02	FLAT WASHER 3/8
2407	PN08	HEX NUT 3/8-16
2408	PN02	HEX NUT 5/16-18
2409	PLW01	LOCK WASHER 5/16
2410	PB07	HEX BOLT 5/16-18 X 3/4



Conveyor System Diagram

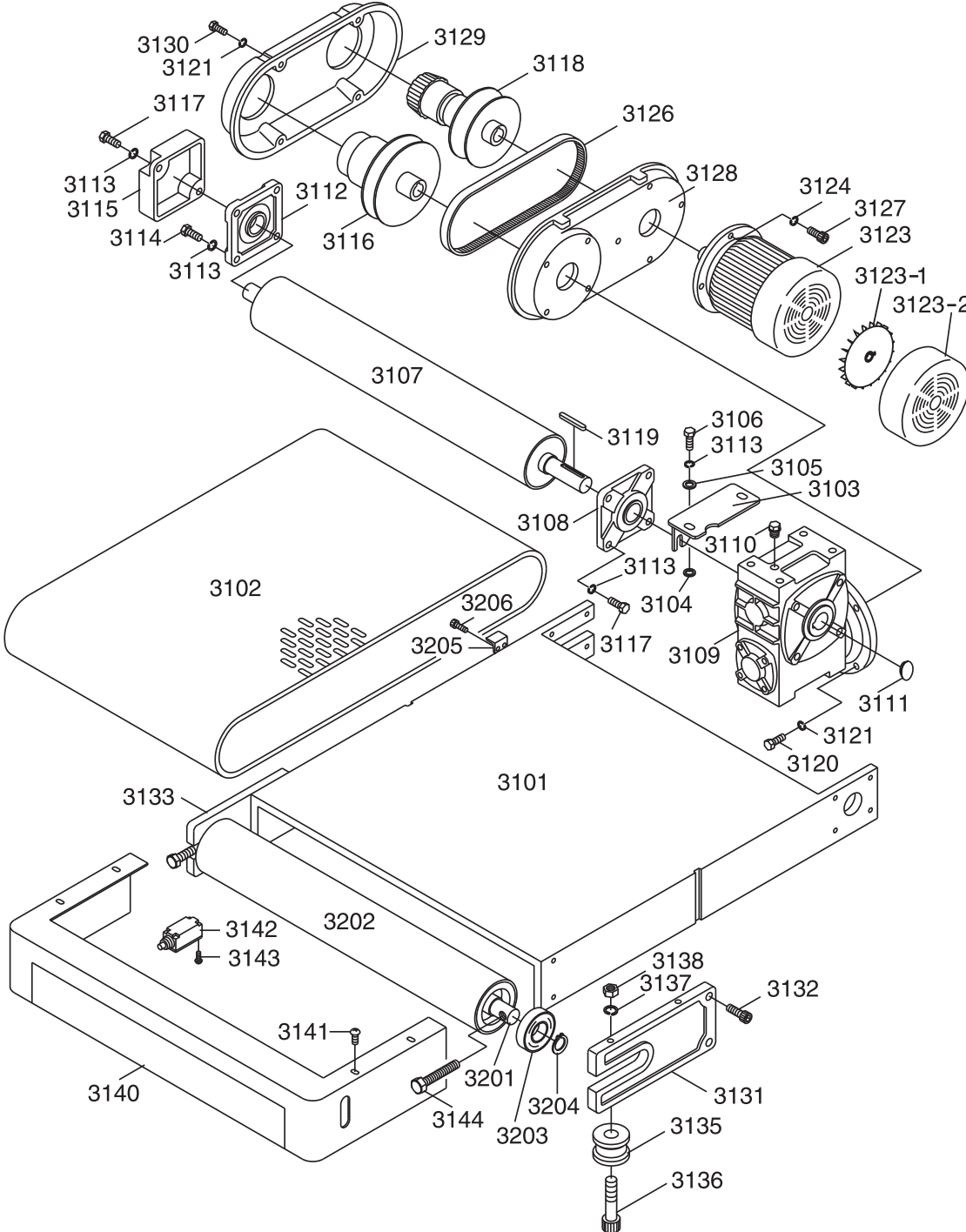

Conveyor System Parts List

REF	PART #	DESCRIPTION
3101	P9962Z3101	CONVEYOR TABLE
3102	P9962Z3102	CONVEYOR BELT
3103	P9962Z3103	GEARBOX FIX PLATE
3104	P9962Z3104	CUSHION
3105	PW02	FLAT WASHER 3/8
3106	PB18	HEX BOLT 3/8-16 X 1
3107	P9962Z3107	OUTFEED ROLLER
3108	P9962Z3108	BEARING UCF205
3109	P9962Z3109	REDUCER
3110	P9962Z3110	PLUG
3111	P9962Z3111	PLUG
3112	P9962Z3112	BEARING UCF205
3113	PLW04	LOCK WASHER 3/8
3114	PB24	HEX BOLT 3/8-16 X 1-1/4
3115	P9962Z3115	BEARING CAP
3116	P9962Z3116	DRIVE PULLEY
3117	PB16	HEX BOLT 3/8-16 X 1-1/2
3118	P9962Z3118	DRIVE PULLEY
3119	PK66M	KEY 7 X 7 X 55
3120	PB07M	HEX BOLT M8-1.25 X 25
3121	PLW04M	LOCK WASHER 8MM
3123	P9962Z3123	1 HP MOTOR 1-PH (G9962Z)
3123-1	P9962Z3123-1	MOTOR FAN COVER (G9962Z)
3123-2	P9962Z3123-2	MOTOR FAN (G9962Z)
3123	P9962ZX3123	1 HP MOTOR 3-PH (G9962ZX/G0582/G0445)
3123-1	P9962ZX3123-1	MOTOR FAN (G9962ZX/G0582/G0445)

REF	PART #	DESCRIPTION
3123-2	P9962ZX3123-2	FAN COVER (G9962ZX/G0582/G0445)
3124	PLW06M	LOCK WASHER 10MM
3126	P9962Z3126	TIMING BELT
3127	PB32M	HEX BOLT M10-1.5 X 25
3128	P9962Z3128	VARIABLE SPEED BASE PLATE
3129	P9962Z3129	VARIABLE SPEED COVER
3130	PB09M	HEX BOLT M8-1.25 X 20
3131	P9962Z3131	INFEEED ROLLER BRACKET
3132	PSB16	CAP SCREW 3/8-16 X 3/4
3133	P9962Z3133	INFEEED ROLLER BRACKET
3135	P9962Z3135	POSITIONING WHEEL
3136	PSB70	CAP SCREW 5/16-18 X 2
3137	PLW01	LOCK WASHER 5/16
3138	PN02	HEX NUT 5/16-18
3140	P9962Z3140	FRONT BRAKE COVER
3141	PS04	PHLP HD SCR 1/4-20 X 1/2
3142	P9962Z3142	LIMIT SWITCH
3143	PS31	PHLP HD SCR #10-24 X 1-3/4
3144	PB74	HEX BOLT 1/2-13 X 3
3201	P9962Z3201	INFEEED ROLLER SHAFT
3202	P9962Z3202	INFEEED ROLLER
3203	P6206	BEARING 6206ZZ
3204	PR15M	EXT RETAINING RING 30MM
3205	P9962Z3205	ELEVATION LIMITER
3206	PSB32	CAP SCREW 1/4-20 X 1-1/4



Feed, Drum, and Pressure Roller Diagram

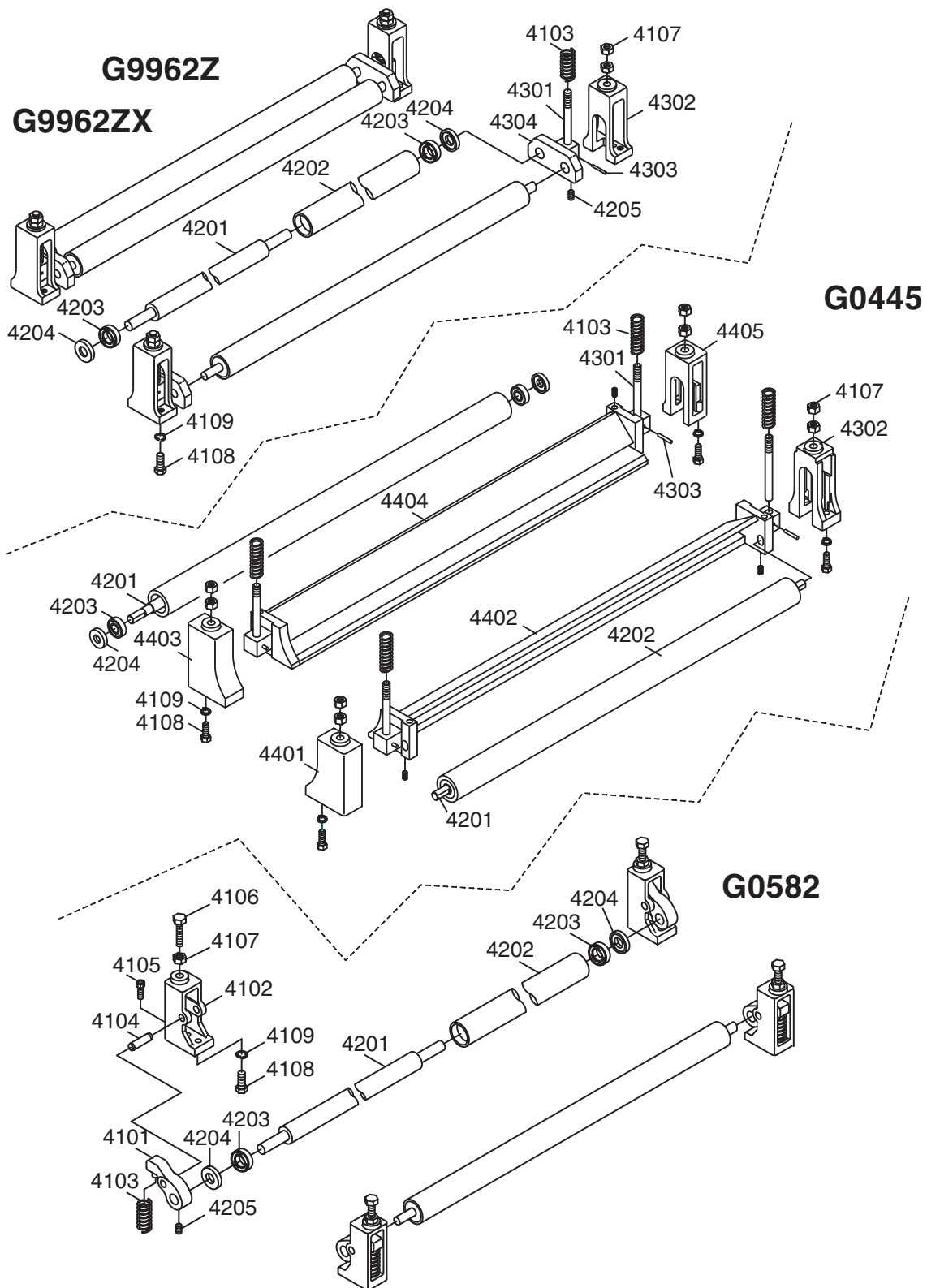

Feed, Drum, and Pressure Roller Parts List

REF	PART #	DESCRIPTION
4101	P05824101	PISTON SLIDE RAIL (G0582)
4102	P05824102	PISTON BRACKET (G0582)
4103	P9962Z4103	COMPRESSION SPRING
4104	P9962Z4104	ROD 10 X 35 (G0582)
4105	PSS07	SET SCREW 1/4-20 X 1/2 (G0582)
4106	PB11	HEX BOLT 5/16-18 X 1-1/2 (G0582)
4107	PN02	HEX NUT 5/16-18
4108	PB12	HEX BOLT 5/16-18 X 1-1/4
4109	PLW01	LOCK WASHER 5/16
4201	P9962Z4201	PISTON ROLLER SHAFT
4202	P9962Z4202	PISTON ROLLER
4203	P6001	BEARING 6001ZZ
4204	P9962Z4204	SHAFT BEARING COLLAR

REF	PART #	DESCRIPTION
4205	PSS07	SETSCREW 1/4-20 X 1/2
4301	P9962Z4301	PISTON ROD (G9962Z/G9962ZX/G0445)
4302	P9962Z4302	BRACKET (G9962Z/G9962ZX/G0445)
4303	PRP55M	ROLL PIN 3 x 27
4304	P9962Z4304	SLIDERAIL (G9962Z/G9962ZX)
4401	P04454301	BRACKET (G0445)
4402	P04454302	DEFLECTOR (G0445)
4403	P04454303	BRACKET (G0445)
4404	P04454304	DEFLECTOR (G0445)
4405	P04454305	BRACKET (G0445)



Sanding Drum and Platen System Diagram

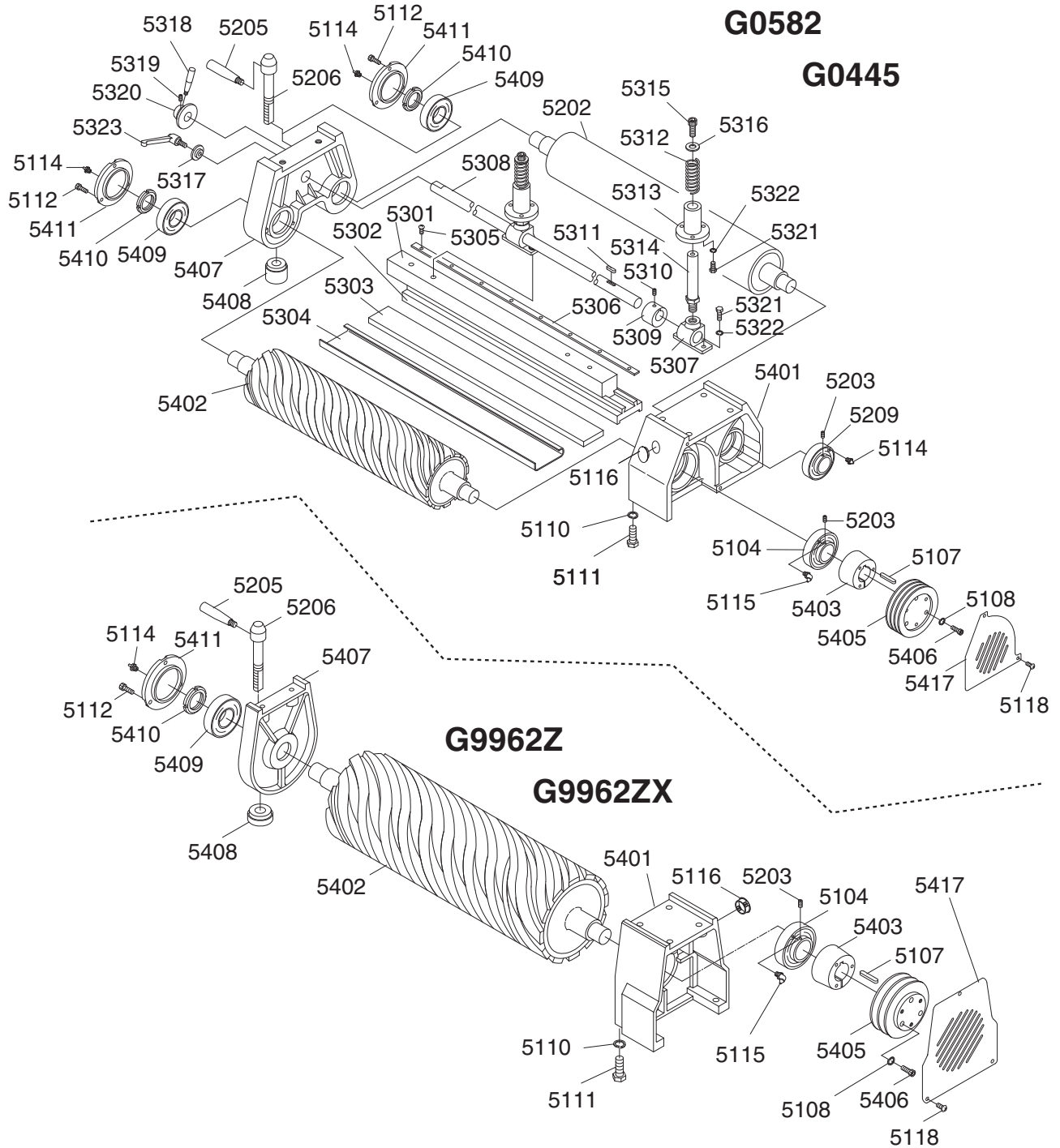

Sanding Drum, and Platen System Parts List

REF	PART #	DESCRIPTION
5104	P9962Z5104	BEARING UCC206
5107	PK11	KEY 5/16 X 5/16 X 1-3/16
5108	PLW01	LOCK WASHER 5/16
5110	PLW07	LOCK WASHER 1/2
5111	PB41	HEX BOLT 1/2-12 X 1-1/2
5112	PSB04	CAP SCREW 1/4-20 X 1/2
5114	P9962Z5114	GREASE FITTING W/ CAP
5115	P9962Z5115	45° GREASE FITTING W/CAP
5116	P9962Z5116	PLUG
5118	PS04	PHLP HD SCR 1/4-20 X 1/2
5202	P05825202	ROLLER (G0582/G0445)
5202	P9962Z5202	ROLLER (G9962Z/G9962ZX)
5203	PSS02M	SET SCREW M6-1.0 X 6
5204	P05825204	BEARING UCC205
5205	P9962Z5205	HANDLE
5206	P9962Z5206	ROLLER LOCKDOWN SHAFT
5301	P05825301	BRACKET MALE (G0582/G0445)
5302	P05825302	BRACKET FEMALE (G0582/G0445)
5303	P05825303	FELT PAD (G0582/G0445)
5304	P05825304	GRAPHITE (G0582/G0445)
5305	PS01	PHLP HD SCR 10-24 X 1/2
5306	P05825306	PLATE (G0582/G0445)
5307	P05825307	BRACKET BASE (G0582/G0445)
5308	P05825308	BRACKET SHAFT (G0582/G0445)
5309	P05825309	LOCK COLLAR (G0582/G0445)
5310	PSS03	SET SCREW 1/4-20 X 3/8 (G0582/G0445)
5311	PK34M	KEY 5 X 5 X 20 (G0582/G0445)
5312	P05825312	COMPRESSION SPRING (G0582/G0445)
5313	P05825313	HOUSING (G0582/G0445)

REF	PART #	DESCRIPTION
5314	P05825314	BRACKET SHAFT (G0582/G0445)
5315	PSB16	CAP SCREW 3/8-16 X 3/4 (G0582/G0445)
5316	PW02	FLAT WASHER 3/8 (G0582/G0445)
5317	P05825317	SPCL. WASHR 3/8 (G0582/G0445)
5318	P05825318	HANDLE (G0582/G0445)
5319	PSS08	SET SCREW 5/16-18 X 1/2
5320	P05825320	ADJUSTMENT RING (G0582/G0445)
5321	PB03	HEX BOLT 5/16-18 X 1 (G0582/G0445)
5322	PW07	FLAT WASHER 5/16 (G0582/G0445)
5323	P05825323	HANDLE (G0582/G0445)
5401	P05825401	HOUSING (G0582/G0445)
5401	P9962Z5401	HOUSING (G9962Z/G9962ZX)
5402	P05825402	ROLLER (G0582/G0445)
5402	P9962Z5402	ROLLER (G9962Z/G9962ZX)
5403	P9962Z5403	FASTENING TUBE
5405	P05825405	PULLEY (G0582/G0445)
5405	P9962Z5405	PULLEY(G9962Z/G9962ZX)
5406	PSB11	CAP SCREW 5/16-18 X 1-1/4
5407	P05825407	HOUSING (G0582/G0445)
5407	P9962Z5407	HOUSING (G9962Z/G9962ZX)
5408	P9962Z5408	BRACKET PAD (G9962Z/G9962ZX)
5408	P05825408	BRACKET PAD (G0582/G0445)
5409	P6206	BEARING 6206-2RS
5410	P9962Z5410	SPANNER NUT
5411	P9962Z5411	BEARING CAP
5417	P05825417	COVER (G0582/G0445)
5417	P9962Z5417	COVER (G9962Z/G9962ZX)



Upper Roller System Diagram

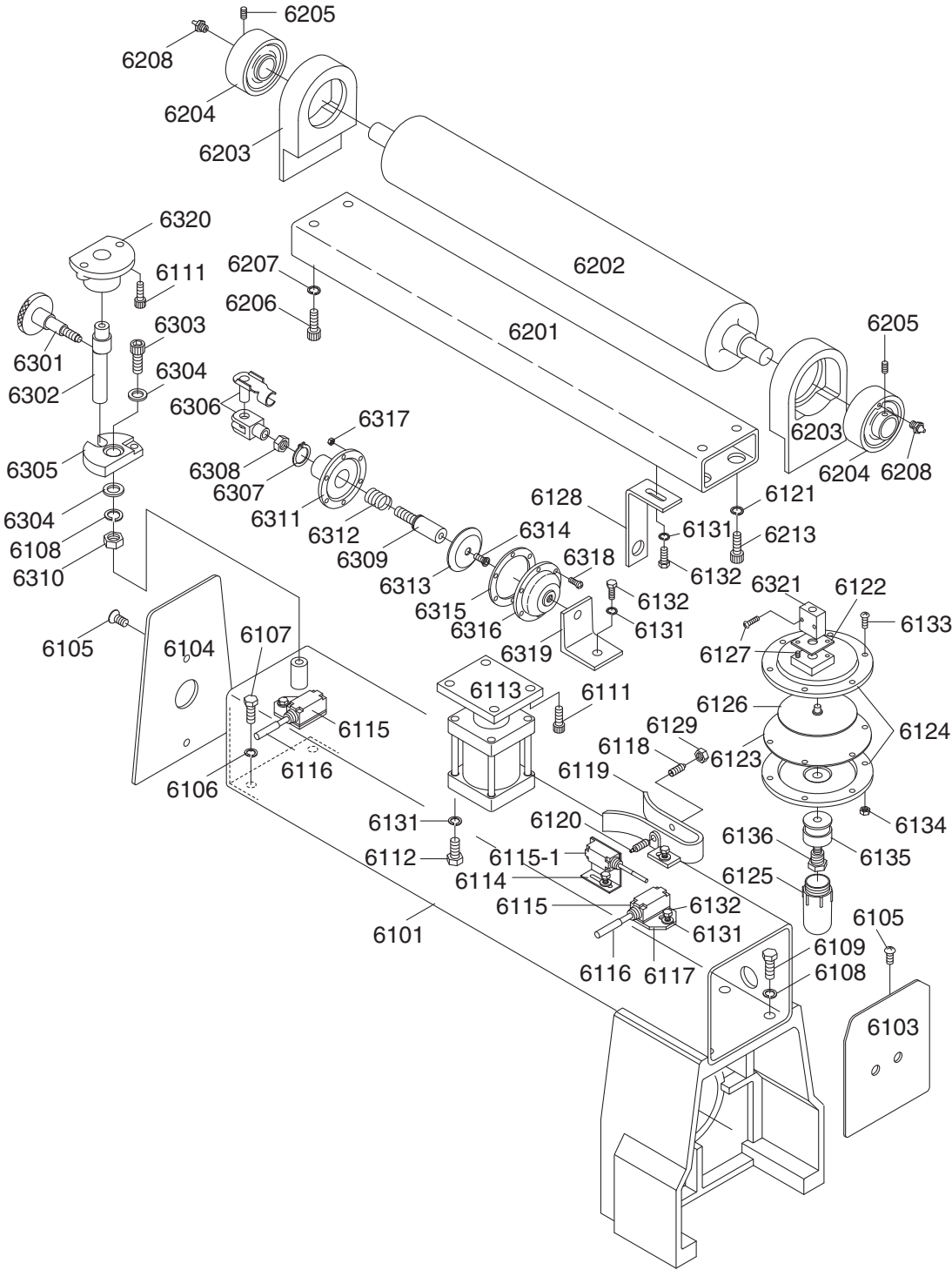

Upper Roller System Parts List

REF	PART #	DESCRIPTION
6101	P04456101	SQUARE FRAME (G0445)
6101	P9962Z6101	SQUARE FRAME (G9962Z/G9962ZX/G0582)
6103	P04456103	FRAME SEAL (RIGHT) (G0445)
6103	P9962Z6103	FRAME SEAL (RIGHT) (G9962Z/G9962ZX/G0582)
6104	P04456104	FRAME SEAL (LEFT) (G0445)
6104	P9962Z6104	FRAME SEAL (LEFT) (G9962Z/G9962ZX/G0582)
6105	PFH05	FLAT HD SCR 1/4-20 X 3/4
6106	PLW04	LOCK WASHER 3/8
6107	PB18	HEX BOLT 3/8-16 X 1
6108	PLW07	LOCK WASHER 1/2
6109	PSB78	CAP SCREW 1/2-12 X 1
6111	PSB07	CAP SCREW 5/16-18 X 3/4
6112	PB09M	HEX BOLT M8-1.25 X 20
6113	P9962Z6113	AIR CYLINDER
6114	P9962Z6114	LIMIT SWITCH HOLDER (L TYPE)
6115	P9962Z6115	LIMIT SWITCH
6115-1	P9962Z6115-1	LIMIT SWITCH
6116	P9962Z6116	LIMIT SWITCH POST
6117	P9962Z6117	LIMIT SWITCH HOLDER
6118	P9962Z6118	AIR SENSOR NOZZLE (FEMALE)
6119	P9962Z6119	AIR CYLINDER BRACKET
6120	P9962Z6120	AIR SENSOR NOZZLE (MALE)
6121	PLW04	LOCK WASHER 3/8
6122	P9962Z6122	THROTTLE VALVE BASE
6123	P9962Z6123	PLATE
6124	P9962Z6124	ALUMINUM DISC
6125	P9962Z6125	OIL CAP
6126	P9962Z6126	ALUMINUM PLATE
6127	PS52M	PHLP HD SCR M4-0.7 X 20
6128	P9962Z6128	BRACKET
6129	PN11	HEX NUT 3/8-24
6131	PLW01	LOCK WASHER 5/16

REF	PART #	DESCRIPTION
6132	PB07	HEX BOLT 5/16-18 X 3/4
6133	PS08	PHLP HD SCR 10-24 X 3/4
6134	PN07	HEX NUT #10-24
6135	P9962Z6135	OIL CAP CONNECTOR
6136	P9962Z6136	OIL CAP SHAFT
6201	P9962Z6201	UPPER ROLLER BRACKET
6202	P9962Z6202	UPPER ROLLER
6203	P9962Z6203	UPPER ROLLER BRACKET
6204	P9962Z6204	BEARING UCC205
6205	PSS02M	SETSCREW M6-1.0 X 6
6206	PSB16	CAP SCREW 3/8-16 X 3/4
6207	PLW04	LOCK WASHER 3/8
6208	P9962Z6208	GREASE FITTING
6212	PSB16	CAP SCREW 3/8-16 X 3/4
6213	PLW04	LOCK WASHER 3/8
6301	P9962Z6301	FIRING ADJUSTER
6302	P9962Z6302	ECCENTRIC ROD
6303	PSB79	CAP SCREW 1/2-12 X 3-1/2
6304	PW01	FLAT WASHER 1/2
6305	P9962Z6305	ECCENTRIC PIECE
6306	P9962Z6306	UNIVERSAL JOINT FORK
6307	PR05M	EXT RETAINING RING 15MM
6308	PN02M	HEX NUT M10-1.5
6309	P9962Z6309	AIR CYLINDER SHAFT
6310	PN06	HEX NUT 1/2-12
6311	P9962Z6311	BOTTOM COVER
6312	P9962Z6312	SPRING
6313	P9962Z6313	ALUMINUM PLATE
6314	PS14M	PHLP HD SCR M6-1.0 X 12
6315	P9962Z6315	PLATE
6316	P9962Z6316	TOP COVER
6317	PN06M	HEX NUT M5-0.8
6318	PS20M	PHLP HD SCR M5-0.8 X 15
6319	P9962Z6319	AIR CYLINDER BRACKET
6320	P9962Z6320	ECCENTRIC SHAFT COLLAR
6321	P9962Z6321	VALVE ASSY.



Cabinet Assembly Diagram

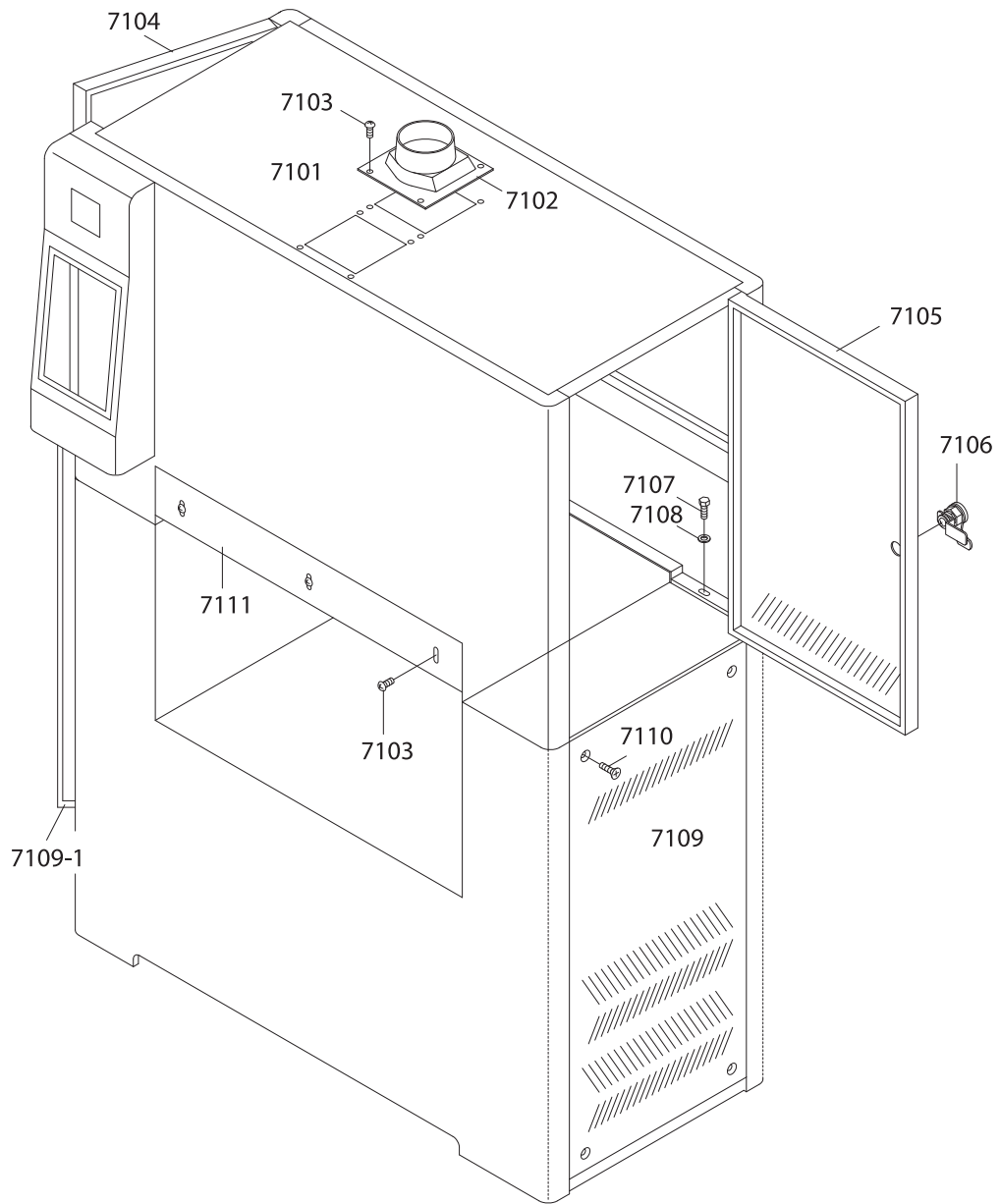

Cabinet Assembly Parts List

REF	PART #	DESCRIPTION
7101	P9962Z7101	UPPER FRAME COVER (G9962Z/G9962ZX)
7101	P04457101	UPPER FRAME COVER (G0445)
7101	P05827101	UPPER FRAME COVER (G0582)
7102	P9962Z7102	DUST HOOD
7103	PS39M	PHLP HD SCR M6-1.0 X 10
7104	P9962Z7104	LEFT DOOR, UPPER FRAME (G9962Z/G9962ZX)
7104	P04457104	LEFT DOOR, UPPER FRAME (G0445)
7104	P05827104	LEFT DOOR, UPPER FRAME (G0582)
7105	P04457105	RIGHT DOOR, UPPER FRAME (G0445)

REF	PART #	DESCRIPTION
7105	P9962Z7105	RIGHT DOOR, UPPER FRAME (G9962Z/G9962ZX)
7105	P05827105	RIGHT DOOR, UPPER FRAME (G0582)
7106	P9962Z7106	DOOR LOCK
7107	PB03	HEX BOLT 5/16-18 X 1
7108	PW07	FLAT WASHER 5/16
7109	P9962Z7109	RIGHT DOOR, LOWER FRAME
7109-1	P9962Z7109-1	LEFT DOOR, LOWER FRAME
7110	PFH03	FLAT HD SCR 1/4-20 X 1/2
7111	P9962Z7111	FRONT PLATE



Main Electrical Panel and Controls Diagram

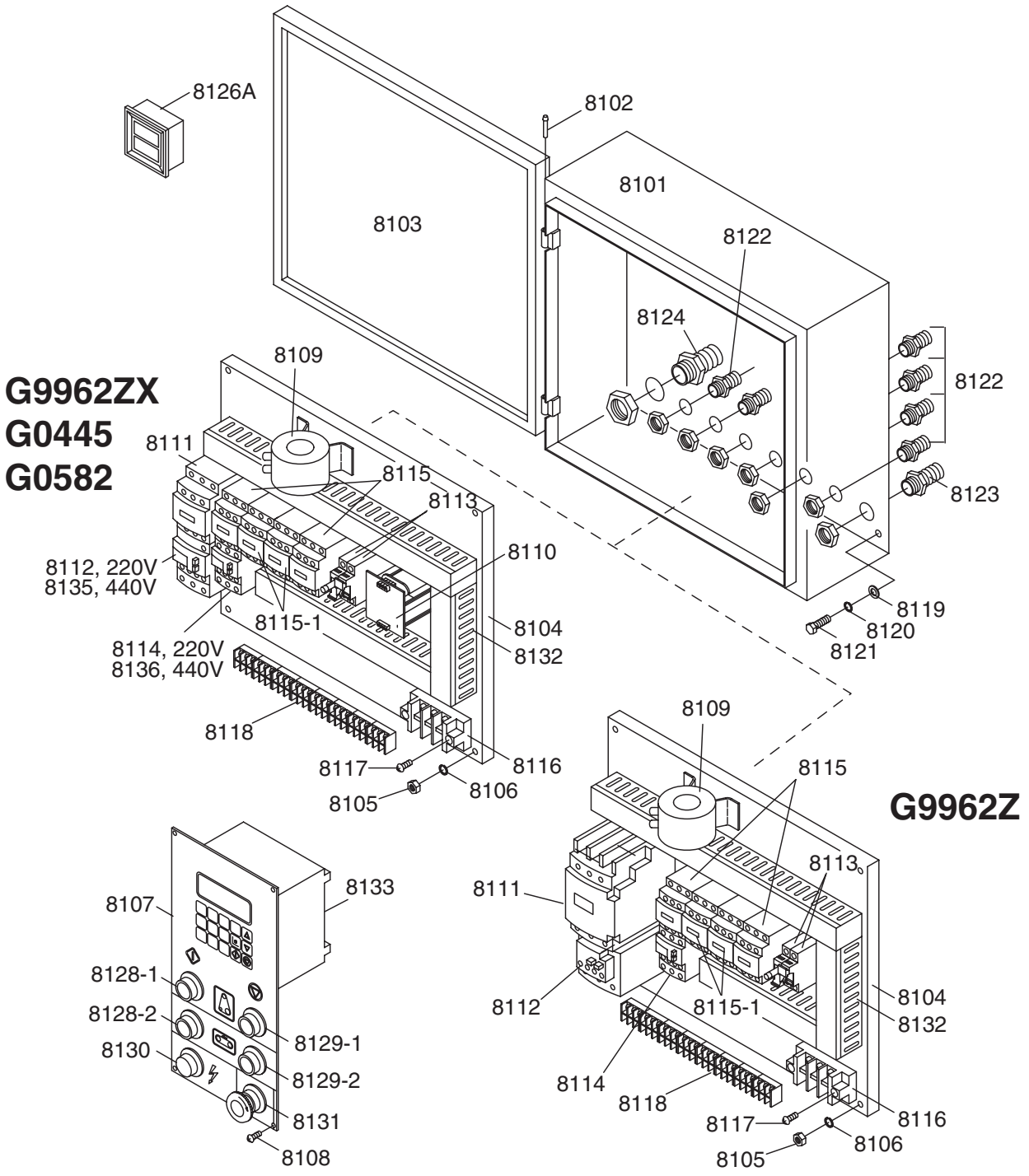

Main Electrical Panel and Controls Parts List

REF	PART #	DESCRIPTION
8101	P9962Z8101	ELECTRICAL CONTROL BOX
8102	P9962Z8102	HINGE
8103	P9962Z8103	CONTROL BOX DOOR
8104	P9962Z8104	BASE PLATE
8105	PN05	HEX NUT 1/4-20
8106	PLW02	LOCK WASHER 1/4
8107	P9962Z8107	CONTROL PANEL
8108	PS07M	PHLP HD SCR M4-0.7 X 8
8109	P9962Z8109	AMP SENSOR (G9962Z)
8109	P9962ZX8109	AMP SENSOR (G0445/G9962ZX/G0582)
8110	P9962ZX8110	TRANSFOMER 220V/440V (G0445/G9962ZX/G0582)
8111	P9962Z8111	CONTACTOR LC1-D50 (G9962Z) 220V
8111	P9962ZX8111	CONTCTR LC1-D386 220V/440V (G0445/G9962ZX/G0582)
8112	P9962Z8112	OVRLD RELAY LR3D-3359 220V (48-65A SET TO 50A) (G9962Z)
8112	P9962ZX8112	OVRLD RELAY LR3D-326 220V (23-32A SET TO 25A) (G0445/G9962ZX/G0582)
8113	P9962Z8113	FUSE HOUSING
8113-1	P9962Z8113-1	FUSE 4 AMP
8114	P9962Z8114	OVRLD RELAY LR3D-126 220V (5.5-8A SET TO 7A)(G9962Z)

REF	PART #	DESCRIPTION
8114	P9962ZX8114	OVRLD RELAY LR3D-086 220V (2.5-4A SET TO 3.4A) (G0445/G9962ZX/G0582)
8115	P9962Z8115	CONTACTOR LC1-D096 220V/440V
8115-1	P9962Z8115-1	CONTACTOR (SET OF 2) LC1-D096 220V/440V
8116	P9962Z8116	POWER WIRE TERMINAL
8117	PS52M	PHLP HD SCR M4-0.7 X 30
8118	P9962Z8118	TERMINAL PLATE
8119	PW06	FLAT WASHER 1/4
8120	PLW02	LOCK WASHER 1/4
8121	PB26	HEX BOLT 1/4-20 X 1/2
8122	P9962Z8122	PU CONNECTOR 1/2
8123	P9962Z8123	PU CONNECTOR 3/4
8124	P9962Z8124	CABLE CONNECTOR 1
8126A	PH29338126A	DIGITAL AMP METER N/S
8128-1	P9962Z8128-1	START SWITCH
8128-2	P9962Z8128-2	START SWITCH
8129-1	P9962Z8129-1	STOP SWITCH
8129-2	P9962Z8129-2	STOP SWITCH
8130	P9962Z8130	POWER INDICATION LIGHT
8131	P9962Z8131	EMERGENCY STOP SWITCH
8132	P9962Z8132	WIRE COLUMN
8133	P9962Z8133	CPU

G0445/G0582/G9962ZX 440V CONVERSION RELAYS

8135	P9962ZX8135	OVRLD RELAY LR3D-216 440V (12-18A SET TO 12.5A) (G0445/G9962ZX/G0582)
8136	P9962ZX8136	OVRLD RELAY LR3D-076 440V (1.6-2.5A SET TO 1.7A) (G0445/G9962ZX/G0582)



Belt Oscillation System Diagram

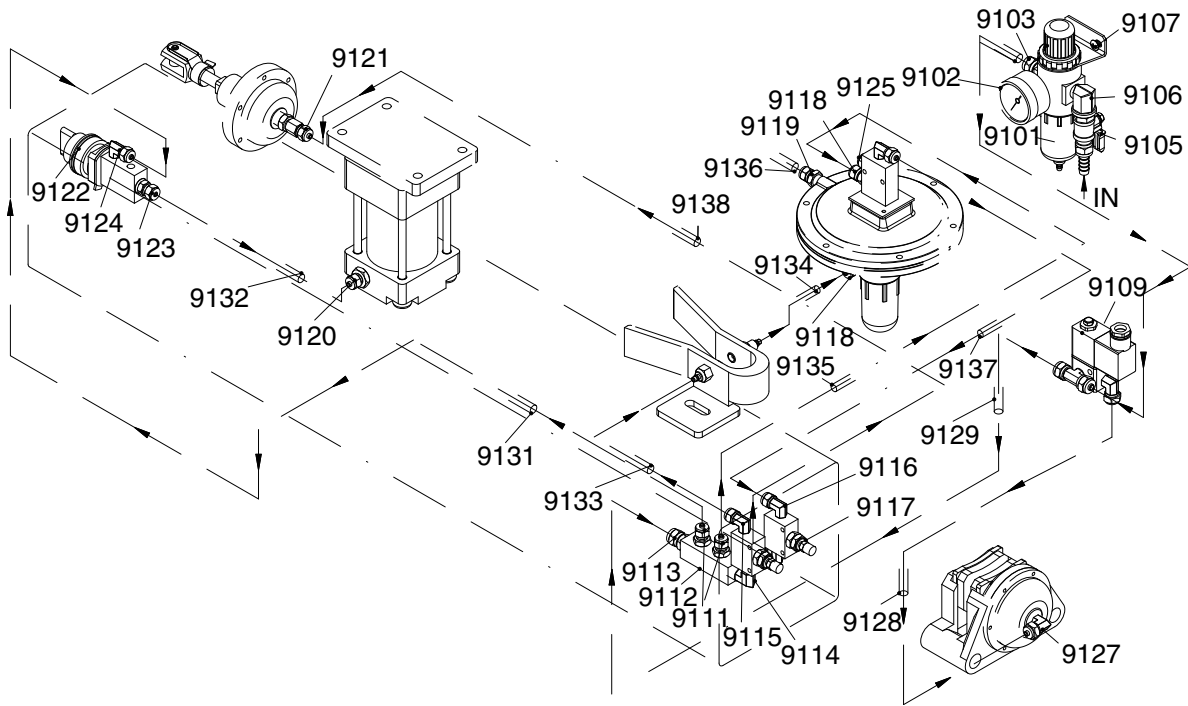

Belt Oscillation System Parts List

REF	PART #	DESCRIPTION
9101	P9962Z9101	FILTER CUP
9102	P9962Z9102	PRESSURE REGULATOR
9103	P9962Z9103	BRONZE CONNECTOR
9105	P9962Z9105	AIR SWITCH
9106	P9962Z9106	ELBOW
9107	PS01	PHLP HD SCR 10-24 X 1/2
9109	P9962Z9109	SOLENOID VALVE
9111	P9962Z9111	PLASTIC CONNECTOR
9112	P9962Z9112	AIR MANIFOLD
9113	P9962Z9113	PLASTIC CONNECTOR
9114	P9962Z9114	ELBOW 1/4N X 1/4N X 90°
9115	P9962Z9115	CONNECTOR 1/4N X 1/8T X 90°
9116	P9962Z9116	CONNECTOR 1/4N X 1/8T X 90°
9117	P9962Z9117	THROTTLE VALVE
9118	P9962Z9118	PLASTIC CONNECTOR
9119	P9962Z9119	BRONZE ELBOW
9120	P9962Z9120	CONNECTOR 1/4N X 1/8T

REF	PART #	DESCRIPTION
9121	P9962Z9121	CONNECTOR 1/4N X 1/8T
9122	P9962Z9122	AIR SWITCH
9123	P9962Z9123	CONNECTOR 1/4N X 1/8T
9124	P9962Z9124	CONNECTOR 1/4N X 1/8T X 90°
9125	P9962Z9125	BUFFER
9127	P9962Z9127	CONNECTOR 1/4N X 1/8T X 90°
9128	P9962Z9128	8MM FLEXIBLE HOSE
9129	P9962Z9129	8MM FLEXIBLE HOSE
9131	P9962Z9131	6MM FLEXIBLE HOSE
9132	P9962Z9132	6MM FLEXIBLE HOSE
9133	P9962Z9133	6MM FLEXIBLE HOSE
9134	P9962Z9134	6MM FLEXIBLE HOSE
9135	P9962Z9135	6MM FLEXIBLE HOSE
9136	P9962Z9136	6MM FLEXIBLE HOSE
9137	P9962Z9137	6MM FLEXIBLE HOSE
9138	P9962Z9138	6MM FLEXIBLE HOSE



Label Diagram

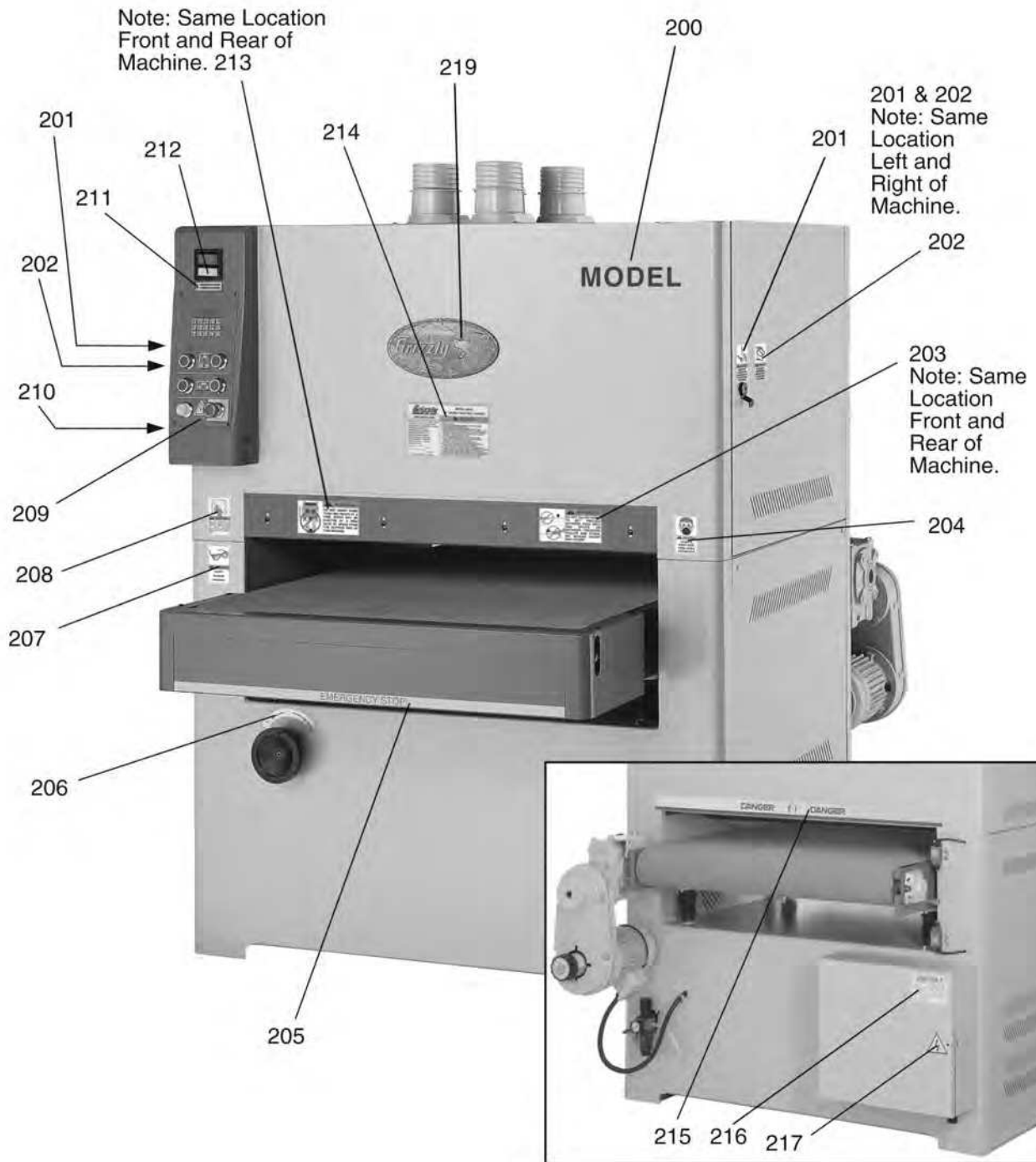

⚠️ WARNING

Safety labels warn about machine hazards and ways to prevent injury. The owner of this machine **MUST** maintain the original location and readability of the labels on the machine. If any label is removed or becomes unreadable, **REPLACE** that label before using the machine again. Contact Grizzly at (800) 523-4777 or www.grizzly.com to order new labels.



Labels List

REF	PART #	DESCRIPTION
200	P9962Z200	LABEL (MODEL G9962Z)
200	P9962ZX200	LABEL (MODEL G9962ZX)
200	P0582200	LABEL (MODEL G0582)
200	P0445200	LABEL (MODEL G0445)
201	PLABEL-13	LABEL (UNPLUG)
202	PLABEL-30	LABEL (CLOSE DOOR)
203	PLABEL-22	LABEL (HAND PINCH)
204	PLABEL-32	LABEL (USE RESPIRATOR)
205	P9962Z205	LABEL (EMERGENCY STOP)
206	P0582206	LABEL (ROTATION)
207	PLABEL-35	LABEL (SAFETY GLASSES)
208	PLABEL-12	LABEL (READ MANUAL)
209	P9962Z209	LABEL (CONTROL PANEL)
210	PLABEL-27	LABEL (CONVERSION CHART)
211	P9962Z211	LABEL (AMP LOAD FOR G9962Z)

REF	PART #	DESCRIPTION
211	P9962ZX211	LABEL (AMP LOAD FOR G9962ZX)
211	P0582211	LABEL (AMP LOAD FOR G0582)
211	P0445211	LABEL (AMP LOAD FOR G0445)
212	P0582212	LABEL (AMP METER)
213	PLABEL-16	LABEL (SANDER KICKBACK)
214	P9962Z7112	LABEL (MACHINE DATA G9962Z)
214	P9962ZX7112	LABEL (MACHINE DATA G9962ZX)
214	P05827112	LABEL (MACHINE DATA G0582)
214	P04457112	LABEL (MACHINE DATA G0445)
215	P9962Z215	LABEL (DANGER STRIPE)
216	PLABEL-34	LABEL (PREWIRED FOR 220V)
216	P9962ZX215	LABEL (PREWIRED FOR 440V)
217	P9962217Z	LABEL (ELECTRICAL)
219	G8589	GRIZZLY LOGO PLATE



Hardware Recognition Chart

USE THIS CHART TO MATCH UP
HARDWARE DURING THE ASSEMBLY
PROCESS!

MEASURE BOLT DIAMETER BY PLACING INSIDE CIRCLE

- #10
- 1/4"
- 5/16"
- 3/8"
- 7/16"
- 1/2"

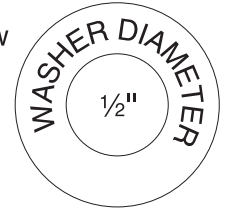
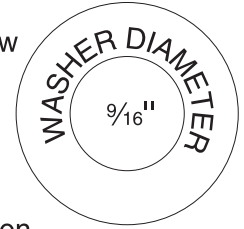
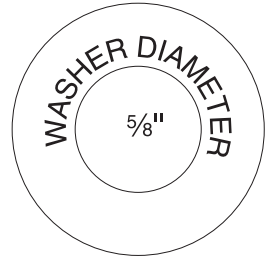
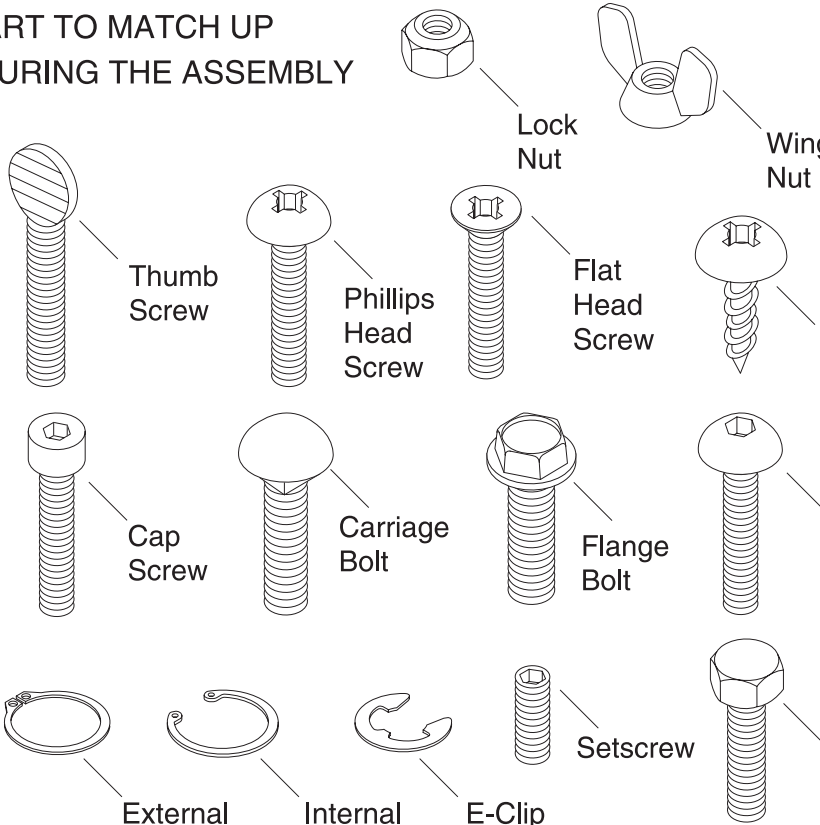

- 4mm
- 6mm
- 8mm
- 10mm
- 12mm
- 16mm

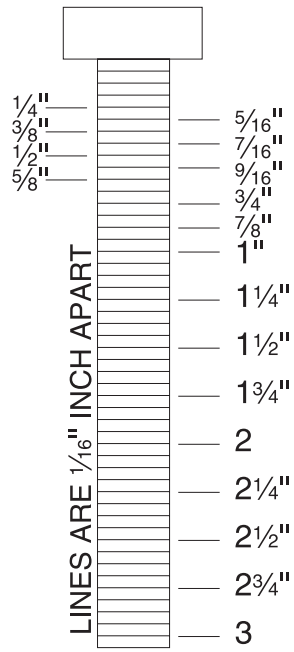
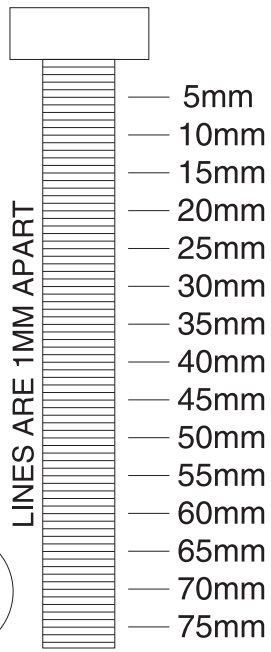

WASHERS ARE MEASURED BY THE INSIDE DIAMETER

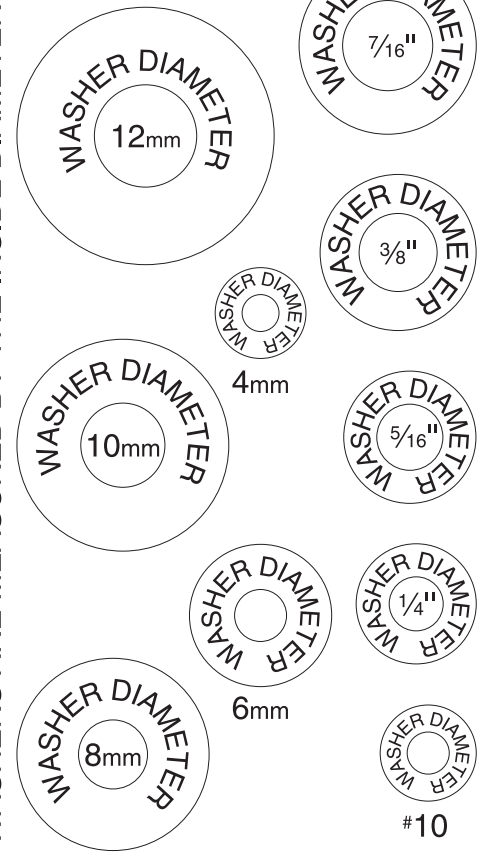

Notes



WARRANTY & RETURNS

Grizzly Industrial, Inc. warrants every product it sells for a period of **1 year** to the original purchaser from the date of purchase. This warranty does not apply to defects due directly or indirectly to misuse, abuse, negligence, accidents, repairs or alterations or lack of maintenance. This is Grizzly's sole written warranty and any and all warranties that may be implied by law, including any merchantability or fitness, for any particular purpose, are hereby limited to the duration of this written warranty. We do not warrant or represent that the merchandise complies with the provisions of any law or acts unless the manufacturer so warrants. In no event shall Grizzly's liability under this warranty exceed the purchase price paid for the product and any legal actions brought against Grizzly shall be tried in the State of Washington, County of Whatcom.

We shall in no event be liable for death, injuries to persons or property or for incidental, contingent, special, or consequential damages arising from the use of our products.

To take advantage of this warranty, contact us by mail or phone and give us all the details. We will then issue you a "Return Number," which must be clearly posted on the outside as well as the inside of the carton. We will not accept any item back without this number. Proof of purchase must accompany the merchandise.

The manufacturers reserve the right to change specifications at any time because they constantly strive to achieve better quality equipment. We make every effort to ensure that our products meet high quality and durability standards and we hope you never need to use this warranty.

Please feel free to write or call us if you have any questions about the machine or the manual.

Thank you again for your business and continued support. We hope to serve you again soon.





WARRANTY CARD

Name _____

Street _____

City _____ State _____ Zip _____

Phone # _____ Email _____ Invoice # _____

Model # _____ Order # _____ Serial # _____

*The following information is given on a voluntary basis. It will be used for marketing purposes to help us develop better products and services. **Of course, all information is strictly confidential.***

1. How did you learn about us?

____ Advertisement

____ Friend

____ Catalog

____ Card Deck

____ Website

____ Other:

2. Which of the following magazines do you subscribe to?

____ Cabinet Maker

____ Popular Mechanics

____ Today's Homeowner

____ Family Handyman

____ Popular Science

____ Wood

____ Hand Loader

____ Popular Woodworking

____ Wooden Boat

____ Handy

____ Practical Homeowner

____ Woodshop News

____ Home Shop Machinist

____ Precision Shooter

____ Woodsmith

____ Journal of Light Cont.

____ Projects in Metal

____ Woodwork

____ Live Steam

____ RC Modeler

____ Woodworker West

____ Model Airplane News

____ Rifle

____ Woodworker's Journal

____ Modeltec

____ Shop Notes

____ Other:

____ Old House Journal

____ Shotgun News

3. What is your annual household income?

____ \$20,000-\$29,000

____ \$30,000-\$39,000

____ \$40,000-\$49,000

____ \$50,000-\$59,000

____ \$60,000-\$69,000

____ \$70,000+

4. What is your age group?

____ 20-29

____ 30-39

____ 40-49

____ 50-59

____ 60-69

____ 70+

5. How long have you been a woodworker/metalworker?

____ 0-2 Years

____ 2-8 Years

____ 8-20 Years

____ 20+ Years

6. How many of your machines or tools are Grizzly?

____ 0-2

____ 3-5

____ 6-9

____ 10+

7. Do you think your machine represents a good value?

____ Yes

____ No

8. Would you recommend Grizzly Industrial to a friend?

____ Yes

____ No

9. Would you allow us to use your name as a reference for Grizzly customers in your area?

Note: *We never use names more than 3 times.*

____ Yes

____ No

10. Comments: _____

CUT ALONG DOTTED LINE

FOLD ALONG DOTTED LINE



Place
Stamp
Here



GRIZZLY INDUSTRIAL, INC.
P.O. BOX 2069
BELLINGHAM, WA 98227-2069



FOLD ALONG DOTTED LINE

Send a Grizzly Catalog to a friend:

Name _____
Street _____
City _____ State _____ Zip _____

TAPE ALONG EDGES--PLEASE DO NOT STAPLE

grizzly.com

TOOL WEBSITE

Buy Direct and Save with Grizzly® – Trusted, Proven and a Great Value!

*Visit Our Website Today And Discover
Why Grizzly® Is The Industry Leader!*

- SECURE ORDERING
- ORDERS SHIPPED WITHIN 24 HOURS
- E-MAIL RESPONSE WITHIN ONE HOUR

-OR-

Call Today For A **FREE**
Full Color Catalog

1-800-523-4777

