

This book is provided *FREE* with
test registration by the
Graduate Record Examinations Board.

GRE[®]

Graduate Record Examinations[®]

This practice book
contains

- one actual full-length GRE
Biochemistry, Cell and
Molecular Biology Test
- test-taking strategies

Become familiar with

- test structure and content
- test instructions and
answering procedures

Compare your practice
test results with the
performance of those
who took the test at a
GRE administration.

BIOCHEMISTRY, CELL AND MOLECULAR BIOLOGY TEST PRACTICE BOOK



*Educational
Testing Service*

Visit GRE Online at www.gre.org

Note to Test Takers: Keep this practice book until you receive your score report.
The book contains important information about content specifications and scoring.

Copyright © 2001 by Educational Testing Service. All rights reserved.
EDUCATIONAL TESTING SERVICE, ETS, the ETS logos, GRADUATE RECORD EXAMINATIONS,
and GRE are registered trademarks of Educational Testing Service.

BIOCHEMISTRY, CELL AND MOLECULAR BIOLOGY TEST
PRACTICE BOOK

Table of Contents

Purpose of the GRE Subject Tests	3
Development of the Subject Tests	3
Content of the Biochemistry, Cell and Molecular Biology Test	4
Preparing for a Subject Test	6
Test-Taking Strategies	7
What Your Scores Mean	7
Practice Biochemistry, Cell and Molecular Biology Test	11
Scoring Your Subject Test	55
Evaluating Your Performance	58
Answer Sheet	59

Purpose of the GRE Subject Tests

The GRE Subject Tests are designed to help graduate school admission committees and fellowship sponsors assess the qualifications of applicants in specific fields of study. The tests also provide you with an assessment of your own qualifications.

Scores on the tests are intended to indicate knowledge of the subject matter emphasized in many undergraduate programs as preparation for graduate study. Because past achievement is usually a good indicator of future performance, the scores are helpful in predicting success in graduate study. Because the tests are standardized, the test scores permit comparison of students from different institutions with different undergraduate programs. For some Subject Tests, subscores are provided in addition to the total score; these subscores indicate the strengths and weaknesses of your preparation, and they may help you plan future studies.

The GRE Board recommends that scores on the Subject Tests be considered in conjunction with other relevant information about applicants. Because numerous factors influence success in

graduate school, reliance on a single measure to predict success is not advisable. Other indicators of competence typically include undergraduate transcripts showing courses taken and grades earned, letters of recommendation, the GRE Writing Assessment score and GRE General Test scores. For information about the appropriate use of GRE scores, write to GRE Program, Educational Testing Service, Mail Stop 57-L, Princeton, NJ 08541, or visit our Web site at www.gre.org/codelst.html.

Development of the Subject Tests

Each new edition of a Subject Test is developed by a committee of examiners composed of professors in the subject who are on undergraduate and graduate faculties in different types of institutions and in different regions of the United States and Canada. In selecting members for each committee, the GRE Program seeks the advice of the appropriate professional associations in the subject.

The content and scope of each test are specified and reviewed periodically by the committee of examiners. Test questions are written by the committee and by other faculty who are also subject-matter specialists and by subject-matter specialists at ETS. All questions proposed for the test are reviewed by the committee and revised as necessary. The accepted questions are assembled into a test in accordance with the content specifications developed by the committee to ensure adequate coverage of the various aspects of the field and, at the same time, to prevent overemphasis on any single topic. The entire test is then reviewed and approved by the committee.

Subject-matter and measurement specialists on the ETS staff assist the committee, providing information and advice about methods of test construction and helping to prepare the questions and assemble the test. In addition, each test question is reviewed to eliminate language, symbols, or content considered potentially offensive, inappropriate for major subgroups of the test-taking population, or likely to perpetuate any negative attitude that may be

conveyed to these subgroups. The test as a whole is also reviewed to ensure that the test questions, where applicable, include an appropriate balance of people in different groups and different roles.

Because of the diversity of undergraduate curricula, it is not possible for a single test to cover all the material you may have studied. The examiners, therefore, select questions that test the basic knowledge and skills most important for successful graduate study in the particular field. The committee keeps the test up-to-date by regularly developing new editions and revising existing editions. In this way, the test content changes steadily but gradually, much like most curricula. In addition, curriculum surveys are conducted periodically to ensure that the content of a test reflects what is currently being taught in the undergraduate curriculum.

After a new edition of a Subject Test is first administered, examinees' responses to each test question are analyzed in a variety of ways to determine whether each question functioned as expected. These analyses may reveal that a question is ambiguous, requires knowledge beyond the scope of the test, or is inappropriate for the total group or a particular subgroup of examinees taking the test. Answers to such questions are not used in computing scores.

Following this analysis, the new test edition is equated to an existing test edition. In the equating process, statistical methods are used to assess the difficulty of the new test. Then scores are adjusted so that examinees who took a difficult edition of the test are not penalized, and examinees who took an easier edition of the test do not have an advantage. Variations in the number of questions in the different editions of the test are also taken into account in this process.

Scores on the Subject Tests are reported as three-digit scaled scores with the third digit always zero. The maximum possible range for all Subject Test total scores is from 200 to 990. The actual range of scores for a particular Subject Test, however, may be smaller. The maximum possible range of Subject Test subscores is 20 to 99; however, the actual range of subscores for any test or test edition may be smaller. Subject Test score interpretive information is provided in *Interpreting Your GRE Scores*, which you will receive with your GRE score report, and on the GRE Web site at www.gre.org/codelst.html.

Content of the Biochemistry, Cell and Molecular Biology Test

The test contains about 180 multiple-choice questions, a number of which are grouped in sets toward the end of the test and based on descriptions of laboratory situations, diagrams, or experimental results.

The content of the test is organized into three major areas: biochemistry, cell biology, and molecular biology and genetics. In addition to the total score, a subscore in each of these subfield areas is reported. Because these three disciplines are basic to the study of all organisms, test questions encompass both eukaryotes and prokaryotes. Throughout the test, there is an emphasis on questions requiring problem-solving skills (including mathematical calculations that do not require the use of a calculator) as well as content knowledge. While only two content areas in the following outline specifically mention methodology, questions on methodology and data interpretation are included in all sections.

In developing questions for the test, the committee keeps in mind both the content of typical courses taken by undergraduates and the knowledge and abilities required for graduate work in the fields related to the test. Because of the diversity of undergraduate curricula, few examinees will have encountered all of the topics in the content outline. Consequently, no examinee should expect to be able to answer all questions on the edition of the test he or she takes. The committee is aware that the three content areas are interrelated. Because of these interrelationships, individual questions or sets of questions may test more than one content area. Therefore, the relative emphases of the three areas in the following outline should not be considered definitive. Likewise, the topics listed are not intended to be all-inclusive but, rather, representative of the typical undergraduate experience.

- I. BIOCHEMISTRY 36%
- A. Chemical and Physical Foundations
 - Thermodynamics and kinetics
 - Redox states
 - Water, pH, acid-base reactions, and buffers
 - Solutions and equilibria
 - Solute-solvent interactions
 - Chemical interactions and bonding
 - Chemical reaction mechanisms
 - B. Biomolecules: Structure, Assembly, Organization, and Dynamics
 - Small molecules
 - Macromolecules (for example, nucleic acids, polysaccharides, proteins, and complex lipids)
 - Supramolecular complexes (for example, membranes, ribosomes, and multienzyme complexes)
 - C. Catalysis and Binding
 - Enzyme reaction mechanisms and kinetics
 - Ligand-protein interaction (for example, hormone receptors, substrates and effectors, transport proteins, and antigen-antibody interactions)
 - D. Major Metabolic Pathways
 - Carbon, nitrogen, and sulfur assimilation
 - Anabolism
 - Catabolism
 - Synthesis and degradation of macromolecules
 - E. Bioenergetics (including respiration and photosynthesis)
 - Energy transformations at the substrate level
 - Electron transport
 - Proton and chemical gradients
 - Energy coupling (phosphorylation and transport)
 - F. Regulation and Integration of Metabolism
 - Covalent modification of enzymes
 - Allosteric regulation
 - Compartmentation
 - Hormones
- G. Methodology
- Spectroscopy
 - Isotopes
 - Separation techniques (for example, centrifugation, chromatography, and electrophoresis)
 - Immunotechniques
- II. CELL BIOLOGY 28%
- A. Cellular Compartments of Prokaryotes and Eukaryotes: Organization, Dynamics, and Functions
 - Cellular membrane systems (structure and transport)
 - Nucleus (envelope and matrix)
 - Mitochondria and chloroplasts (including biogenesis and evolution)
 - B. Cell Surface and Communication
 - Extracellular matrix (including cell walls)
 - Cell adhesion and junctions
 - Signal transduction
 - Receptor function
 - Excitable membrane systems
 - C. Cytoskeleton, Motility, and Shape
 - Actin-based systems (including muscle contraction)
 - Microtubule-based systems
 - Intermediate filaments
 - Prokaryotic systems
 - D. Protein Synthesis and Processing
 - Regulation of translation
 - Posttranslational modification
 - Intracellular trafficking
 - Secretion and endocytosis
 - E. Cell Division, Differentiation, and Development
 - Bacterial division
 - Meiosis and gametogenesis
 - Eukaryotic cell cycles, mitosis, and cytokinesis
 - Fertilization and early embryonic development (including positional information, homeotic genes, tissue-specific expression, nuclear and cytoplasmic interactions, growth factors and induction, environment, and polarity)

III. MOLECULAR BIOLOGY 36%

AND GENETICS

- A. Genetic Foundations
 - Mendelian and non-Mendelian inheritance
 - Transformation, transduction, and conjugation
 - Recombination and complementation
 - Mutational analysis
 - Genetic mapping and linkage analysis
- B. Chromatin and Chromosomes
 - Karyotypes
 - Translocations, inversions, deletions, and duplications
 - Aneuploidy and polyploidy
 - Structure
- C. Genomics
 - Genome structure
 - Physical mapping
 - Repeated DNA and gene families
 - Gene identification
 - Transposable elements
- D. Genome Maintenance
 - DNA replication
 - DNA damage and repair
 - DNA modification
 - DNA recombination and gene conversion
- E. Gene Expression
 - The genetic code
 - Transcription
 - RNA processing
 - Translation
- F. Gene Regulation in Prokaryotes
 - Positive and negative control of the operon
 - Promoter recognition by RNA polymerases
 - Attenuation and antitermination
- G. Gene Regulation in Eukaryotes
 - Cis*-acting regulatory elements
 - Trans*-acting regulatory factors
 - Gene rearrangements and amplifications

- H. Bacteriophages and Animal and Plant Viruses
 - Genome replication and regulation
 - Virus assembly
 - Virus-host interactions
- I. Methodology
 - Restriction maps
 - Nucleic acid blotting and hybridization
 - DNA cloning in prokaryotes and eukaryotes
 - Sequencing and analysis
 - Protein-nucleic acid interaction

Preparing for a Subject Test

GRE Subject Test questions are designed to measure skills and knowledge gained over a long period of time. Although you might increase your scores to some extent through preparation a few weeks or months before you take the test, last-minute cramming is unlikely to be of further help. The following information may be helpful.

- A general review of your college courses is probably the best preparation for the test. However, the test covers a broad range of subject matter, and no one is expected to be familiar with the content of every question.
- Use this practice book to become familiar with the types of questions in the GRE Biochemistry, Cell and Molecular Biology Test, paying special attention to the directions. If you thoroughly understand the directions before you take the test, you will have more time during the test to focus on the questions themselves.

Test-Taking Strategies

The questions in the practice test in this book illustrate the types of multiple-choice questions in the test. When you take the test, you will mark your answers on a separate machine-scorable answer sheet. Total testing time is two hours and fifty minutes; there are no separately timed sections. Following are some general test-taking strategies you may want to consider.

- Read the test directions carefully, and work as rapidly as you can without being careless. For each question, choose the best answer from the available options.
- All questions are of equal value; do not waste time pondering individual questions you find extremely difficult or unfamiliar.
- You may want to work through the test quite rapidly, first answering only the questions about which you feel confident, then going back and answering questions that require more thought, and concluding with the most difficult questions if there is time.
- If you decide to change an answer, make sure you completely erase it and fill in the oval corresponding to your desired answer.
- Questions for which you mark no answer or more than one answer are not counted in scoring.
- As a correction for haphazard guessing, one-fourth of the number of questions you answer incorrectly is subtracted from the number of questions you answer correctly. It is improbable that mere guessing will improve your score significantly; it may even lower your score. If, however, you are not certain of the correct answer but have some knowledge of the question and are able to eliminate one or more of the answer choices, your chance of getting the right answer is improved, and it may be to your advantage to answer the question.

- Record all answers on your answer sheet. Answers recorded in your test book will not be counted.
- Do not wait until the last five minutes of a testing session to record answers on your answer sheet.

What Your Scores Mean

Your raw score—that is, the number of questions you answered correctly minus one-fourth of the number you answered incorrectly—is converted to the scaled score that is reported. This conversion ensures that a scaled score reported for any edition of a Subject Test is comparable to the same scaled score earned on any other edition of the same test. Thus, equal scaled scores on a particular Subject Test indicate essentially equal levels of performance regardless of the test edition taken. Test scores should be compared only with other scores on the same Subject Test. (For example, a 680 on the Computer Science Test is not equivalent to a 680 on the Mathematics Test.)

Before taking the test, you may find it useful to know approximately what raw scores would be required to obtain a certain scaled score. Several factors influence the conversion of your raw score to your scaled score, such as the difficulty of the test edition and the number of test questions included in the computation of your raw score. Based on recent editions of the Biochemistry, Cell and Molecular Biology Test, the table on the next page gives the range of raw scores associated with selected scaled scores for three different test editions. (Note that when the number of scored questions for a given test is greater than the range of possible scaled scores, it is likely that two or more raw scores will convert to the same scaled score.) The three test editions in the table that follows were selected to reflect varying degrees of difficulty. Examinees should note that future test editions may be somewhat more or less difficult than the test editions illustrated in the table.

**Range of Raw Scores* Needed
to Earn Selected Scaled Scores on
Three Biochemistry, Cell and Molecular
Biology Test Editions That Differ in Difficulty**

Scaled Score	Raw Scores		
	Form A	Form B	Form C
700	131-134	123-125	119-121
600	100-103	95-96	90-92
500	69-72	66-68	62-64
400	38-41	37-39	33-35
Number of Questions Used to Compute Raw Score			
	178	180	177

*Raw Score = Number of correct answers minus one-fourth the number of incorrect answers, rounded to the nearest integer.

For a particular test edition, there are many ways to earn the same raw score. For example, on the edition listed above as “Form A,” a raw score of 69 through 72 would earn a scaled score of 500. Below are a few of the possible ways in which a scaled score of 500 could be earned on that edition.

**Examples of Ways to Earn
a Scaled Score of 500 on the
Edition Labeled as “Form A”**

Raw Score	Questions Answered Correctly	Questions Answered Incorrectly	Questions Not Answered	Number of Questions Used to Compute Raw Score
69	69	0	109	178
69	80	43	55	178
69	91	87	0	178
72	72	0	106	178
72	83	43	52	178
72	93	85	0	178

Practice Test

To become familiar with how the administration will be conducted at the test center, first remove the answer sheet (pages 59 and 60). Then go to the back cover of the test book (page 54) and follow the instructions for completing the identification areas of the answer sheet. When you are ready to begin the test, note the time and begin marking your answers on the answer sheet.

22

GRADUATE RECORD EXAMINATIONS®

GRE®



BIOCHEMISTRY, CELL
AND MOLECULAR
BIOLOGY TEST

*Do not break the seal
until you are told to do so.*

*The contents of this test are confidential.
Disclosure or reproduction of any portion
of it is prohibited.*

THIS TEST BOOK MUST NOT BE TAKEN FROM THE ROOM.

Copyright © 1999, 2000 by Educational Testing Service. All rights reserved.
GRE, GRADUATE RECORD EXAMINATIONS, ETS, EDUCATIONAL TESTING
SERVICE and the ETS logo are registered trademarks of Educational Testing Service.
The modernized ETS logo is a trademark of Educational Testing Service.

BIOCHEMISTRY, CELL AND MOLECULAR BIOLOGY TEST

Time—170 minutes

180 Questions

Directions: Each of the questions or incomplete statements below is followed by five suggested answers or completions. Select the one that is best in each case and then completely fill in the corresponding space on the answer sheet.

1. RNA molecules that exhibit catalytic activity are called
- (A) mRNAs
 - (B) ribonucleases
 - (C) ribosomes
 - (D) ribozymes
 - (E) ribonucleotides

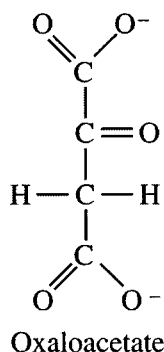
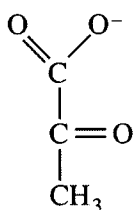

2. The conversion of pyruvate to oxaloacetate (structures shown above) is likely to require which of the following coenzymes?
- (A) Biotin
 - (B) Vitamin B₁₂
 - (C) Thiamine pyrophosphate
 - (D) Pyridoxal phosphate
 - (E) Flavin adenine dinucleotide
3. Which of the following hormones initiates biological actions by crossing the plasma membrane and then binding to a receptor?
- (A) Glucagon
 - (B) Estradiol
 - (C) Insulin
 - (D) Norepinephrine
 - (E) Adrenocorticotrophic hormone

4. Which of the following takes place during oxidative phosphorylation in mitochondria?
- (A) Protons are pumped from the matrix to the intermembrane space.
 - (B) Protons are pumped from the intermembrane space to the matrix.
 - (C) Electrons are pumped from the matrix to the intermembrane space.
 - (D) Electrons are pumped from the intermembrane space to the matrix.
 - (E) NADH is pumped from the matrix to the intermembrane space.
5. An enzyme that catalyzes the reaction $A \rightleftharpoons B$ changes the
- (A) heat of reaction
 - (B) equilibrium constant
 - (C) equilibrium concentration of A
 - (D) entropy of the reaction
 - (E) rate of both the forward and reverse reactions
6. The major mechanism of turnover of molecular components of the plasma membrane occurs through
- (A) endocytosis of patches of membrane
 - (B) diffusion of individual molecules into the cytoplasm
 - (C) recovery of specific components by selective receptors
 - (D) expulsion of integral molecules into the extracellular medium
 - (E) the concerted action of multifunctional enzyme complexes

7. Cells with abundant apical microvilli are characteristically found in
- (A) exocrine glands
 - (B) the reticuloendothelial system
 - (C) adipose tissue
 - (D) neuronal dendrites
 - (E) absorptive epithelia
8. Diacylglycerol activates which of the following enzymes?
- (A) Protein kinase A
 - (B) Protein kinase C
 - (C) MAP kinase
 - (D) Tyrosine kinase
 - (E) Phosphorylase *b* kinase
9. Cellular proteins destined for secretion are sorted and packaged in the
- (A) lysosomes
 - (B) endosomes
 - (C) endoplasmic reticulum
 - (D) *trans* Golgi network
 - (E) peroxisomes
10. Incubation of gram-negative bacteria with lysozyme in an isotonic medium causes rod-shaped bacteria to assume a spherical shape. The cause of this phenomenon is
- (A) absorption of water
 - (B) destruction of the cell wall
 - (C) destruction of the cytoskeleton
 - (D) damage to the plasma membrane
 - (E) change in gene expression
11. Virus-mediated transfer of cellular genetic material from one bacterial cell to another by means of virus particles is called
- (A) induction
 - (B) transfection
 - (C) transformation
 - (D) transposition
 - (E) transduction
12. Which of the following processes leads to formation of polytene chromosomes?
- (A) Nondisjunction of chromatids during meiosis
 - (B) Recombination between adjacent chromosome segments
 - (C) Sister chromatid exchange
 - (D) Inactivation of one chromosome of each homologous pair
 - (E) Repeated replication without separation of chromatids
13. True statements about retrotransposons include which of the following?
- I. They replicate through an RNA intermediate.
 - II. They utilize reverse transcriptase for replication.
 - III. They may contain introns.
- (A) I only
 - (B) III only
 - (C) I and III only
 - (D) II and III only
 - (E) I, II, and III
14. Which of the following is true about a circular double-stranded DNA genome that is determined by chemical means to be 21 percent adenosine?
- (A) The genome is 10.5% guanosine.
 - (B) The genome is 21% guanosine.
 - (C) The genome is 29% guanosine.
 - (D) The genome is 58% guanosine.
 - (E) The base percent composition of guanosine in the genome cannot be determined from the information given.

15. In the classical model of transcriptional control described by Jacob and Monod, a repressor protein binds to

- (A) an enhancer
- (B) an AUG sequence
- (C) an operator
- (D) a ribosome-binding site
- (E) a TATA box

16. In an intact cell, the free energy change ($\Delta G'$) associated with an enzyme-catalyzed reaction is frequently different from the standard free energy change (ΔG°) of the same reaction because in the intact cell the

- (A) activation energy is different
- (B) reaction is always near equilibrium
- (C) enzyme may be regulated allosterically
- (D) reactants are not at 1 M concentrations
- (E) reaction may be catalyzed by more than one enzyme

<u>Half-reaction</u>	<u>E°(V)</u>
Fumarate + 2 H ⁺ + 2 e ⁻ → succinate	0.031
Oxaloacetate + 2 H ⁺ + 2 e ⁻ → malate	-0.166
Pyruvate + 2 H ⁺ + 2 e ⁻ → lactate	-0.185
Acetaldehyde + 2 H ⁺ + 2 e ⁻ → ethanol	-0.197
NAD ⁺ + H ⁺ + 2 e ⁻ → NADH	-0.320
Acetoacetate + 2 H ⁺ + 2 e ⁻ → β -hydroxybutyrate	-0.346

17. Which of the following redox reactions would be expected to proceed as written? (Assume standard conditions and the presence of appropriate enzymes; E° values are shown above.)

- (A) Malate + NAD⁺ → oxaloacetate + NADH + H⁺
- (B) Acetoacetate + NADH + H⁺ → β -hydroxybutyrate + NAD⁺
- (C) Pyruvate + β -hydroxybutyrate → lactate + acetoacetate
- (D) Malate + pyruvate → oxaloacetate + lactate
- (E) Acetaldehyde + succinate → ethanol + fumarate

18. Plants and some bacteria differ from animals in that plants and some bacteria can
- form polymers from glucose
 - use carbon dioxide to increase their biomass
 - produce NADH via reductive reactions
 - synthesize glutamate and aspartate
 - use glucose by the glycolytic pathway
19. Which of the following can act as a nucleophile in metabolic reactions?
- Nitrogen of an amino group
 - Oxygen of a hydroxyl group
 - Carbon of a carbonyl group
- I only
 - II only
 - III only
 - I and II only
 - I, II, and III
20. In addition to proteins, major components of very low density lipoproteins (VLDL) circulating in the blood of a normally fed mammal include
- triacylglycerol, cholesterol, and phospholipid
 - triacylglycerol, squalene, and phospholipid
 - triacylglycerol, squalene, and sphingosine
 - monoacylglycerol, cholesterol, and phospholipid
 - monoacylglycerol, squalene, and sphingosine
21. Elevation of intracellular inositol trisphosphate (IP₃) results in a release of Ca²⁺ from which of the following organelles?
- Peroxisome
 - Lysosome
 - Mitochondrion
 - Nucleus
 - Smooth endoplasmic reticulum
22. Which of the following is the last to occur after the binding of a sea urchin sperm to an egg?
- Increase in cytosolic pH
 - Increase in calcium concentration
 - Activation of protein synthesis
 - Initiation of mRNA synthesis
 - Exocytosis of cortical granules
23. All of the following are true about heterotrimeric G proteins EXCEPT:
- They bind either GDP or GTP.
 - They have GTPase activity.
 - They act as binary (on-off) switches.
 - They help amplify a hormone's signal.
 - They phosphorylate proteins.
24. The completion of the S phase of the cell cycle of a mammalian cell is marked by all of the following EXCEPT:
- Histone content per cell is double that of cells in G₁.
 - In replicated DNA, newly incorporated bases are paired with parental bases.
 - Each replicated chromosome has four telomeres.
 - Sister chromatids disjoin from one another.
 - The nucleus contains the equivalent amount of DNA of a tetraploid cell in G₁.
25. In the lysosomal storage disease called I-cell disease, all of the hydrolases normally found in lysosomes are instead found in the bloodstream. Which of the following is the most likely cause of this disease?
- Lack of phosphorylation of lysosomal enzymes
 - A nonfunctional proton pump in the lysosomal membrane
 - A mutation in the clathrin gene
 - Inability of the endoplasmic reticulum to form lysosomal vesicles
 - Absence of sialic acid on glycolipids in the Golgi complex
26. All of the following contribute to promoter binding by RNA polymerase in *E. coli* EXCEPT the
- rho factor
 - 10 consensus sequence
 - 35 consensus sequence
 - β' subunit of RNA polymerase
 - β subunit of RNA polymerase

27. "Zinc fingers" are important in cellular regulation because they are
- (A) at the catalytic site of many kinases
 - (B) a structural motif in many DNA-binding proteins
 - (C) characteristic of palindromic stretches of unique-sequence DNA
 - (D) restricted to the cytoplasmic domain of growth-factor receptors
 - (E) structures with high redox potential
28. In prokaryotes, environmental sensing frequently involves regulatory proteins (two-component systems) that sense and respond to changes in surroundings. These two-component systems may involve which of the following?
- I. Protein phosphorylation
 - II. Transcriptional regulation
 - III. Membrane proteins
- (A) I only
 - (B) II only
 - (C) III only
 - (D) II and III only
 - (E) I, II, and III
29. In the cross $AaBb \times AaBb$, Mendel's principle of independent assortment predicts that the ratio of the four possible phenotypes of the offspring will be
- (A) 1 : 1 : 1 : 1
 - (B) 3 : 2 : 2 : 1
 - (C) 4 : 2 : 2 : 1
 - (D) 9 : 3 : 3 : 1
 - (E) 9 : 7 : 3 : 1
30. Common lesions found in DNA after exposure to ultraviolet light are
- (A) pyrimidine dimers
 - (B) single strand breaks
 - (C) base deletions
 - (D) purine dimers
 - (E) transpositions

31. Which of the following pairs of structures depicts stereoisomers according to conventional rules of projection?

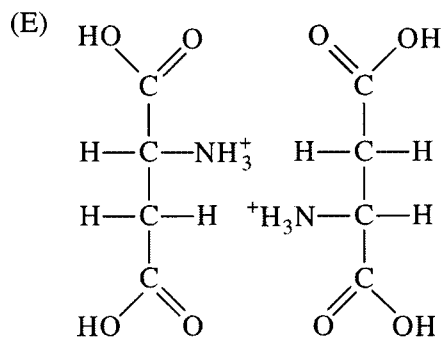
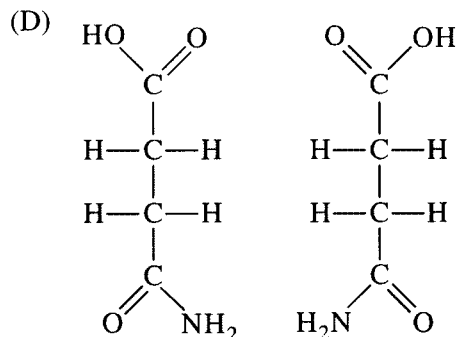
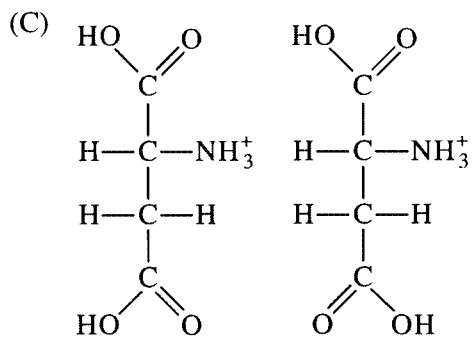
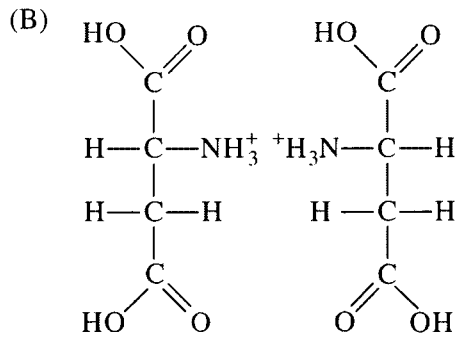
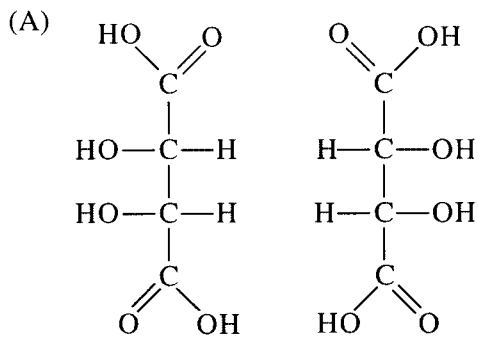

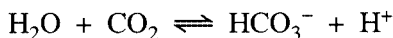

32. The reaction shown above is conducted in a closed system containing gaseous CO_2 and a buffered aqueous solution. If the reaction is allowed to reach equilibrium, the final concentration of bicarbonate ions in the aqueous phase would most likely be increased by
- (A) adding water while keeping the partial pressure of CO_2 constant
 - (B) adding carbonic anhydrase
 - (C) increasing the pH of the buffered aqueous solution
 - (D) reducing the partial pressure of CO_2
 - (E) reducing the temperature of the reaction solution
33. Which of the following types of bonds or interactions are LEAST likely to be involved in stabilizing the three-dimensional folding of most proteins?
- (A) Hydrogen bonds
 - (B) Electrostatic bonds
 - (C) Hydrophobic interactions
 - (D) Disulfide bonds
 - (E) Ester bonds
34. In animals, an enzyme unique to gluconeogenesis is
- (A) enolase
 - (B) phosphoglyceromutase
 - (C) glyceraldehyde 3-phosphate dehydrogenase
 - (D) aldolase
 - (E) fructose 1,6-bisphosphatase
35. Approximately how many moles of ATP will be generated as a result of the oxidation of one mole of FADH_2 in an actively respiring mitochondrion?
- (A) 0
 - (B) 2.0
 - (C) 3.0
 - (D) 4.5
 - (E) 6.0
36. If a subcellular fraction from liver tissue exhibits a high level of acid phosphatase activity, it most likely contains
- (A) nuclei
 - (B) lysosomes
 - (C) endoplasmic reticulum
 - (D) coated vesicles
 - (E) mitochondria
37. Evidence indicating that chloroplasts were originally free-living prokaryotes that subsequently evolved a symbiotic relationship with a eukaryotic host includes all of the following EXCEPT the
- (A) similarities of rRNA sequences between chloroplasts and free-living prokaryotes
 - (B) similarities in structure between chloroplasts and some contemporary free-living prokaryotes
 - (C) presence of circular DNA in chloroplasts and in free-living prokaryotes
 - (D) susceptibility of chloroplasts to inhibitors of prokaryotic protein synthesis
 - (E) ability of chloroplasts to synthesize all their own proteins
38. Which of the following is NOT a characteristic of intermediate filaments?
- (A) They form the nuclear lamina.
 - (B) They provide mechanical stability to animal cells.
 - (C) Their protein composition is tissue specific.
 - (D) They are composed of globular monomers that polymerize to form fibers.
 - (E) They include the keratin filaments of epithelial cells.
39. The amino acid sequence of a novel membrane protein contains four immunoglobulin-like domains and six fibronectin-like repeats. This protein is most likely a
- (A) cell adhesion molecule
 - (B) hormone-responsive ion channel
 - (C) G protein
 - (D) protein-serine/threonine kinase
 - (E) transcription factor

40. Which of the following is correct concerning the evolution of Photosystem II in cyanobacteria?
- It made Photosystem I in these organisms unnecessary for photosynthetic fixation of carbon dioxide.
 - It provided these organisms with an almost inexhaustible supply of electrons from water.
 - It allowed these organisms to use any electron donor to replace electrons lost from excited chlorophyll *a* molecules.
 - It allowed photochemically produced ATP to be exported to the cytoplasm.
 - It allowed these organisms to generate ATP for the fixation of carbon dioxide into sugars without chemiosmosis.
41. Which of the following sequences of events occurs when *E. coli* are released from catabolite repression by transfer to low-glucose medium?
- cAMP levels rise, cAMP binds to CAP, cAMP-CAP complex binds to a site on DNA and activates transcription.
 - cAMP levels rise, cAMP binds to CAP, cAMP-CAP complex binds to a site on DNA and represses transcription.
 - cAMP levels rise, cAMP binds to CAP, cAMP-CAP complex is removed from a site on DNA and activates transcription.
 - cAMP levels fall, cAMP is removed from CAP, CAP binds to a site on DNA and activates transcription.
 - cAMP levels fall, cAMP is removed from CAP, CAP binds to a site on DNA and represses transcription.
42. The ability of yeast to produce invertase, an enzyme necessary to metabolize sucrose, was abolished by either of two mutations, m-1 and m-2, that arose spontaneously in two separate yeast cultures. A heterozygote formed by mating m-1 mutant cells with m-2 mutant cells would be expected to restore the yeast's ability to produce invertase if m-1 and m-2 are
- mutations of two separate nonallelic genes
 - in the same complementation groups
 - identical alleles of the same gene
 - suppressible by the same suppressor
 - both temperature-sensitive mutations
43. All of the following components of a retrovirus are encoded by the viral genome EXCEPT
- matrix proteins
 - viral RNA's
 - capsid proteins
 - envelope lipids
 - receptor-binding proteins
44. Some viruses have increased the coding potential of their genome by
- integrating into the host genome
 - using host ribosomes for translation
 - using alternative splicing sites
 - using a degenerate triplet code
 - covalently linking a protein to the genome
45. Which of the following is most likely to lead to a loss of gene function?
- A missense mutation in the open reading frame
 - A change from a TAA codon to a TAG codon in the coding region
 - A change from T to C in the promoter region
 - A frameshift mutation in the coding region
 - A sequence change in the 3' untranslated region
46. The molar absorption coefficient (extinction coefficient) of NADH at 340 nanometers is 6,220 liters per mole per centimeter, whereas that of NAD at 340 nanometers is 0. What absorbance will be observed when light at 340 nanometers passes through a 1-centimeter cuvette containing 10-micromolar NADH and 10-micromolar NAD?
- 0.031
 - 0.062
 - 0.124
 - 0.31
 - 0.62
47. All of the following processes occur in the mitochondria of mammalian cells EXCEPT
- fatty acid biosynthesis
 - protein synthesis
 - DNA synthesis
 - beta oxidation of fatty acids
 - the citric acid cycle

48. Rubisco catalyzes the carboxylation and also the oxygenation of ribulose 1,5-bisphosphate. The initial products of these reactions include which of the following?
- Glyceraldehyde 3-phosphate
 - 2-Phosphoglycolate
 - 3-Phosphoglycerate
- (A) I only
(B) II only
(C) III only
(D) I and II
(E) II and III
49. Which of the following is meant by the statement that glucose and mannose are epimers?
- (A) One is an aldose and the other is a ketose.
(B) One is a pyranose and the other is a furanose.
(C) They are mirror images of each other.
(D) They rotate the plane of light in opposite directions.
(E) They differ only in the configuration about one carbon atom.
50. A solution contains DNA polymerase I, Mg^{2+} salts of dATP, dGTP, dCTP, and dTTP, and an appropriate buffer. Which of the following DNA molecules would serve as a template for DNA synthesis when added to this solution?
- (A) A single-stranded closed circle
(B) A single-stranded closed circle base-paired to a shorter linear strand with a 3'-terminal hydroxyl
(C) A single-stranded closed circle base-paired to a shorter linear strand with a 3'-terminal phosphate
(D) A double-stranded closed circle
(E) A blunt-ended, double-stranded linear molecule with a 3'-terminal hydroxyl at each end
51. Which of the following enzymes plays a direct role in the biosynthesis of collagen?
- (A) Prolyl hydroxylase
(B) Tyrosine hydroxylase
(C) Choline oxidase
(D) Monoamine oxidase
(E) Tryptophan oxygenase
52. Organized clathrin structures are typically associated with the
- (A) nuclear envelope and endoplasmic reticulum
(B) lysosomes
(C) *trans* Golgi network and plasma membrane
(D) extracellular matrix
(E) inner membrane complexes of mitochondria and chloroplasts
53. If the M-phase-promoting factor is injected into a *Xenopus* primary oocyte, which of the following occurs?
- (A) S phase begins.
(B) The oocyte enters G_0 .
(C) Apoptosis begins.
(D) The germinal vesicle (nucleus) breaks down.
(E) Mitosis is completed.
54. Actin filaments are found in all of the following EXCEPT the
- (A) flagella of bacteria
(B) sarcomeres of skeletal muscle cells
(C) stress fibers of fibroblasts
(D) microvilli of the intestinal brush border
(E) contractile rings of dividing animal cells
55. Which of the following does NOT make direct use of a pH or proton gradient?
- (A) Mitochondrion
(B) Chloroplast
(C) Cyanobacterium
(D) Protozoan cilium
(E) Bacterial flagellum
56. A study is done on a mammalian cell line that has a doubling time of 24 hours. These cells are synchronized in G_1 and then labeled for 2 days with BrdU (an analog of thymidine that increases the density of DNA into which it is incorporated). At the end of the labeling period, chromosomal DNA is isolated from the cells and its density analyzed by equilibrium centrifugation in cesium chloride gradients. Which of the following patterns would be expected to be seen?
(H = heavy, L = light)
- (A) 100% H/H
(B) 100% H/L
(C) 50% H/H, 50% H/L
(D) 50% H/H, 50% L/L
(E) 25% H/H, 50% H/L, 25% L/L

57. Which of the following statements is correct concerning a homeobox?
- (A) It is part of the promoter in eukaryotic genes that code for proteins involved in segmentation.
 - (B) It is a conserved protein structure found in glycolytic pathway enzymes.
 - (C) It is a conserved protein structure found in tRNA-binding proteins.
 - (D) It is a conserved DNA sequence found in genes that code for proteins that regulate development.
 - (E) It is a conserved DNA sequence found in genes that code for proteins that regulate homeostasis.
58. Which of the following best describes the function of the sigma subunit in the RNA polymerase of *E. coli*?
- (A) It is essential for elongation of the RNA transcript.
 - (B) It is essential for the recognition of and binding to the promoter sequence.
 - (C) It increases RNA polymerase binding to any DNA template.
 - (D) It is required for transcription termination.
 - (E) It keeps the core complex from dissociating.
59. When bacteriophage lambda infects a sensitive bacterium, one of the first messenger RNA species synthesized is very short, beginning at a site P_L and extending just through an adjacent gene N . After the appearance of the gene N protein, messages become much longer, still beginning at P_L but extending far beyond gene N . The N gene encodes
- (A) an antiterminator acting just beyond gene N
 - (B) a new sigma factor acting on a promoter beyond gene N
 - (C) an activator for a promoter beyond gene N
 - (D) an antirepressor that removes a protein repressor bound at gene N
 - (E) a protein that stabilizes the longer message
60. When the coding region of a prokaryotic gene is cloned into the *lac Z* gene downstream from the translational initiator, the chance of an in-frame fusion is
- (A) 1/2
 - (B) 1/3
 - (C) 1/5
 - (D) 1/6
 - (E) 1/9
61. What is the pK_a for trimethylammonium in water if the base ionization constant (K_b) for trimethylamine is 7.4×10^{-5} ?
- ($\log 7.4 \times 10^{-5} = -4.13$)
- (A) -4.13
 - (B) 2.87
 - (C) 4.13
 - (D) 9.87
 - (E) 11.13
62. The source of oxygen for O_2 production during photosynthesis by higher plants is
- (A) CO_2
 - (B) HCO_3^-
 - (C) H_2O
 - (D) ATP
 - (E) chlorophyll
63. The rate-limiting step of fatty acid synthesis is catalyzed by
- (A) acetyl CoA carboxylase
 - (B) ATP-citrate lyase
 - (C) malic enzyme
 - (D) pyruvate dehydrogenase
 - (E) thiolase

64. Which of the following is true about the change in enthalpy (ΔH) of a reaction that is spontaneous at room temperature?
- (A) It is equal to $T \Delta S$.
 (B) It is positive and the reaction is exothermic.
 (C) It is negative and the reaction is endothermic.
 (D) It must be equal to zero.
 (E) It can be either positive or negative.
65. Which of the following intermediate compounds is involved when a peptide is hydrolyzed by chymotrypsin?
- (A) An ester between the substrate's acyl carbon and the serine of the active site
 (B) A thioester between the substrate's acyl carbon and the cysteine of the active site
 (C) An amide between the substrate's acyl carbon and the lysine of the active site
 (D) An amide between the substrate's acyl carbon and the asparagine of the active site
 (E) An amide between the substrate's α -amino group and the aspartate of the active site
66. Heat-shock proteins were originally described as proteins produced in response to heat stress. Some are now known to act as
- (A) molecular chaperones that regulate protein folding
 (B) protein-tyrosine kinases
 (C) proteases that degrade ubiquitin-tagged proteins
 (D) GTPase-activating proteins
 (E) ionophores that dissipate H^+ gradients
67. All of the following statements about the type-B cyclin proteins are correct EXCEPT:
- (A) Their presence is required for exit from mitosis.
 (B) They are present in cells during the G_2 phase.
 (C) They are degraded via the ubiquitin pathway.
 (D) They activate the Cdc2 kinase.
 (E) They are newly synthesized during every cell cycle.
68. Which of the following is an advantage of confocal microscopy over conventional fluorescence microscopy?
- (A) The interaction of a laser beam with the cell surface allows the imaging of individual macromolecules.
 (B) The use of electrons instead of light to image the specimen results in greatly increased resolving power.
 (C) Optical sections can be taken at different depths in a specimen.
 (D) Only scattered light enters the microscope lens, making the object appear illuminated against a dark background.
 (E) The inherent contrast of an unstained specimen is enhanced.
69. Which of the following properties is common to all cytoskeletal motor proteins (such as kinesins, dyneins, and myosins)?
- (A) An actin-binding domain
 (B) Two globular-head domains
 (C) The ability to bind to biological membranes
 (D) ATPase activity
 (E) Two heavy chains and four light chains
70. Which of the following is NOT involved in the processing of mRNA precursors in eukaryotic cells?
- (A) Capping of the 5' end
 (B) Addition of poly A
 (C) Excision of introns
 (D) Splicing of exons
 (E) Transport of the pre-mRNA to the cytoplasm
71. DNA polymerase contains a lysine residue that is important for binding to DNA. Mutations were found that converted this lysine to either glutamate, glycine, valine, or arginine. Which mutations would be predicted to be the most and least harmful to the ability of the enzyme to bind DNA?
- | | <u>Most</u> | <u>Least</u> |
|-----|-------------|--------------|
| (A) | Valine | Aspartate |
| (B) | Glycine | Arginine |
| (C) | Arginine | Glycine |
| (D) | Glutamate | Valine |
| (E) | Glutamate | Arginine |

72. A mammalian zygote resulted from the fusion of a normal gamete with a gamete that formed after a nondisjunction event in one chromosome during meiosis II. Which of the following best describes the zygote?

- (A) Diploid
- (B) Haploid
- (C) Aneuploid
- (D) Polyploid
- (E) Polysomic

73. The specialized structures located at the ends of eukaryotic chromosomes are called

- (A) terminators
- (B) telomeres
- (C) long terminal repeats (LTR's)
- (D) centromeres
- (E) kinetochores

Black body, flat wings:	12.5%
Black body, curved wings:	37.5%
Yellow body, curved wings:	12.5%
Yellow body, flat wings:	37.5%

74. A homozygous male fruit fly with black body color and curved wings is crossed with a virgin homozygous female fruit fly with yellow body color and flat wings. All the offspring of this cross display yellow body color and flat wings. If a virgin female selected from these offspring is mated to a homozygous male fruit fly with black body color and curved wings, four types of offspring will occur in the proportions shown above. Which of the following conclusions can be drawn about the nature of inheritance on the basis of these data?

- (A) Black body color and curved wings are dominant over yellow body color and flat wings.
- (B) The results do not fit the typical 9 : 3 : 3 : 1 ratio, making this an example of multiple allelic inheritance rather than a normal dihybrid cross.
- (C) Recombinant types of offspring, as in this case, appear more frequently than do parental types.
- (D) These genes for body color and wing shape are independently assorting from each other.
- (E) These genes for body color and wing shape are linked.

75. A bacterial protein-coding gene contains a terminator codon in the middle of the coding region, yet expression of the gene in the bacterium produces a functional protein. Translation of the gene probably requires

- (A) the excision of an intron
- (B) a suppressor tRNA
- (C) ribosomes that lack 5S RNA
- (D) an mRNA with no ribosome binding site
- (E) an mRNA with no secondary structure

76. Which of the following is NOT a potential problem associated with expressing a eukaryotic, protein-coding nuclear gene in prokaryotic cells?

- (A) Lack of an intron-splicing mechanism in prokaryotes
- (B) Differences in the translation initiation codons used by eukaryotic cells and prokaryotic cells
- (C) Susceptibility of the protein product to prokaryotic proteases
- (D) Stability of mRNA in prokaryotic cells
- (E) Differences in transcriptional signals between eukaryotic cells and prokaryotic cells

77. Treatment of intact mitochondria with an uncoupler, such as 2,4-dinitrophenol, in the presence of ADP, P_i , succinate, and oxygen would have which of the following effects on the rates of electron transport and ATP synthesis? (+ = stimulation; o = no effect; - = inhibition)

	Rate of <u>Electron Transport</u>	Rate of <u>ATP Synthesis</u>
(A)	+	+
(B)	-	-
(C)	+	-
(D)	-	+
(E)	+	o

78. For the enzyme-catalyzed reaction $S \rightleftharpoons P$, $K_{eq} = 5$, which of the following curves best represents the change in $[S]$ that occurs with time when S is added to a solution containing the appropriate enzyme?

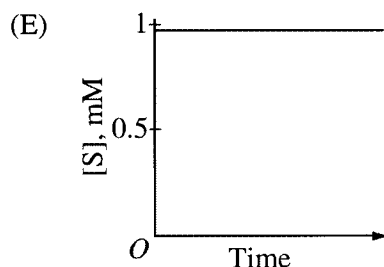
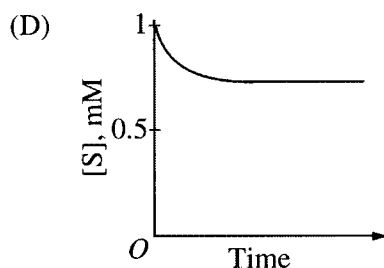
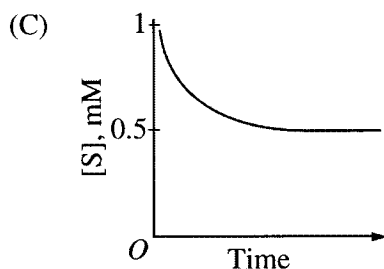
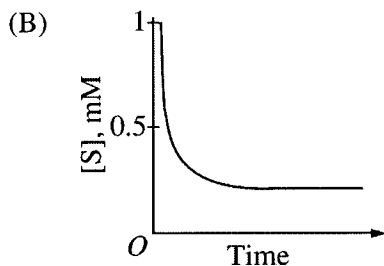
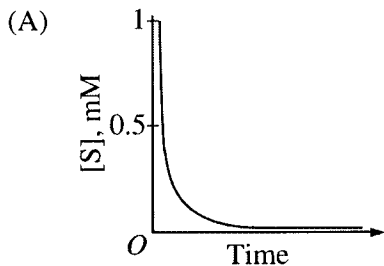

79. All of the following compounds are capable of forming hydrogen bonds with water EXCEPT

- (A) methanol
- (B) acetamide
- (C) methyl acetate
- (D) ethanolamine
- (E) hexane

80. A water-soluble globular protein is most likely to have the highest proportion of which of the following amino acid residues buried within its core?

- (A) Serine
- (B) Histidine
- (C) Isoleucine
- (D) Glutamate
- (E) Lysine

81. Hexokinase activity in a desalted cell extract can be measured in a spectrophotometric assay at 340 nanometers. In addition to buffer, Mg^{2+} , and lysate, the reaction mixture should contain

- (A) glucose, ATP, NADPH, and excess glucose 6-phosphate dehydrogenase
- (B) glucose, ATP, $NADP^+$, and excess glucose 6-phosphate dehydrogenase
- (C) glucose, ADP, $NADP^+$, and excess glucose 6-phosphate dehydrogenase
- (D) glucose, ATP, $NADP^+$, and excess 6-phosphogluconate dehydrogenase
- (E) glucose 6-phosphate, ATP, $NADP^+$, and excess glucose 6-phosphate dehydrogenase

Ester Substrate	Rate of Reaction (micromoles per second)
Methyl acetate	3×10^{-3}
Ethyl acetate	5×10^{-3}
Butyl acetate	2×10^{-2}
Pentyl acetate	5×10^{-2}

82. An esterase with rates of reaction for the hydrolysis of various esters above probably has an enzyme active site that

- (A) contains a thiol
- (B) contains a hydrophobic recognition site
- (C) contains a thiamine pyrophosphate cofactor
- (D) is very similar to that of trypsin
- (E) shows allosteric control

83. Which of the following processes is NOT an example of allosteric regulation?

- (A) Regulation of phosphofructokinase activity by fructose 2,6-bisphosphate
- (B) Inactivation of nitrogenase by ADP-ribosylation
- (C) Regulation of the *lac* operon by allolactose in *E. coli*
- (D) Catabolite repression by CAP in *E. coli*
- (E) Activation of second-messenger synthesis within a cell in response to receptor-ligand binding at the cell surface

84. Which of the following is closest to the pH of a solution that contains 5 millimoles per liter of H^+ ions?

- (A) 1.2
- (B) 2.3
- (C) 3.7
- (D) 6.5
- (E) 7.5

85. Although multiple disulfide bonds are possible during the formation of the tertiary structure of some secretory proteins, only the “correct” ones are found in the secreted product. This is primarily due to the fact that

- (A) incorrectly folded proteins are degraded by lysosomes
- (B) processing and folding is continued in the endosomes
- (C) a protein facilitates the formation of correct disulfide bonds in the endoplasmic reticulum
- (D) only correctly folded proteins are translated in the endoplasmic reticulum
- (E) arginine residues guide the proper positioning of disulfide bonds

86. Actin filaments and microtubules share all of the following properties EXCEPT:

- (A) They are involved in cell motility.
- (B) They are intrinsically polar structures.
- (C) They can associate with motor proteins.
- (D) They are assembled from subunits that are heterodimers.
- (E) They can be cross-linked into bundles.

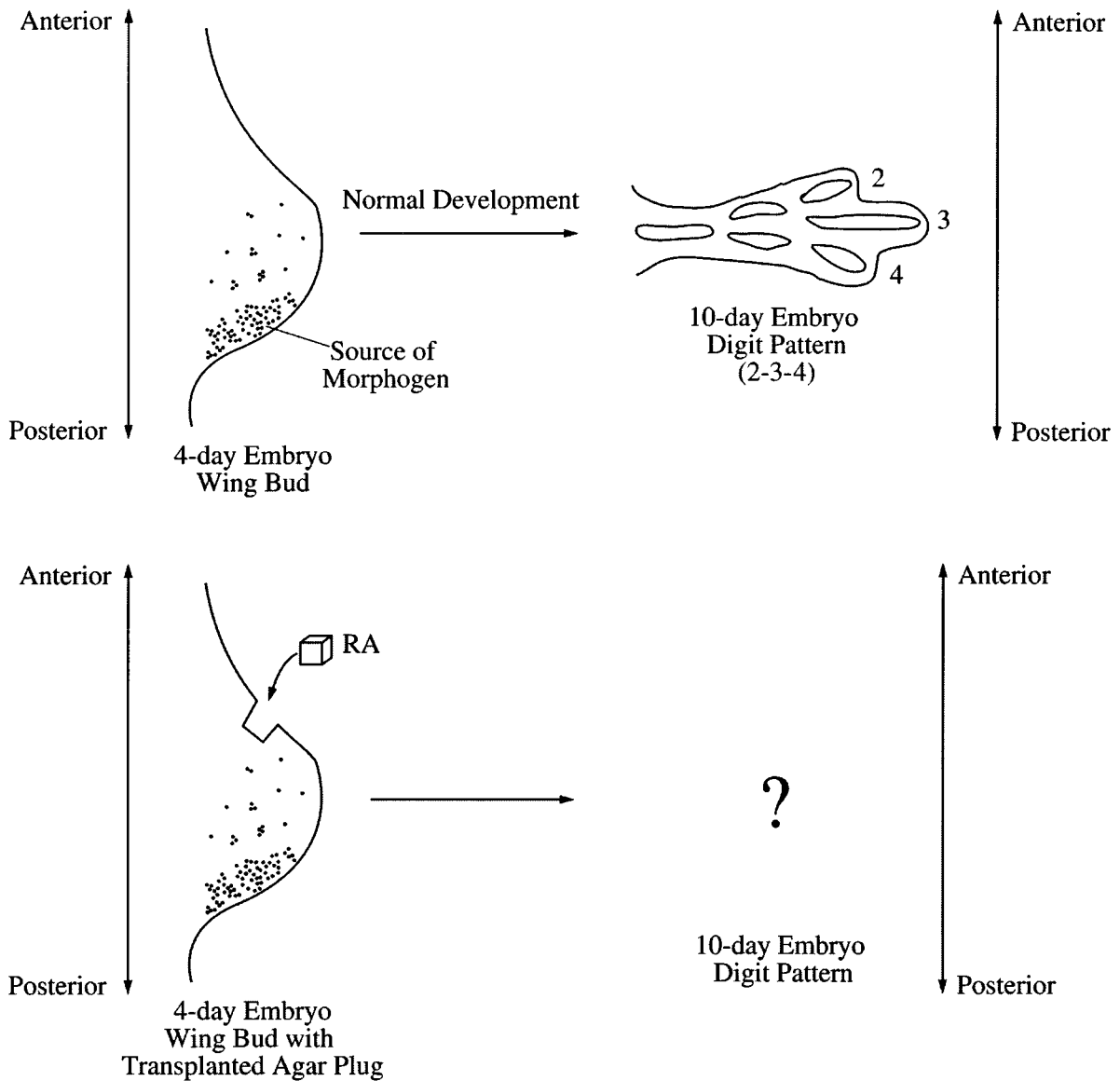

87. During wing development in the chicken embryo, the digit pattern (2-3-4) is thought to be controlled by a morphogen concentration gradient that originates in the posterior of the young wing bud as indicated in the diagram above. An agar plug soaked in retinoic acid (RA) can mimic the action of the morphogen. Which of the following digit patterns would be expected to result if an agar plug soaked in retinoic acid were placed in the anterior of a developing wing bud?

- (A) 2 – 3 – 4 only
- (B) 4 – 3 – 2 only
- (C) 2 – 3 – 4 – 4 – 3 – 2
- (D) 4 – 3 – 2 – 2 – 3 – 4
- (E) 4 – 3 – 2 – 4 – 3 – 2

88. The recognition site of the restriction endonuclease *AvaI* is CPyCGPuG, where Py is any pyrimidine and Pu is any purine. What is the expected average distance, in nucleotide pairs, between *AvaI* cleavage sites in a random DNA sequence?

- (A) 4,096
- (B) 1,024
- (C) 682
- (D) 64
- (E) 6

89. In a bacterial cell, a mutation in an aminoacyl-tRNA synthetase leads to charging of the entire tRNA^{Ser} population with alanine. Which of the following describes the result of using these aminoacyl tRNAs for protein synthesis in the cell?

- (A) The alanyl-tRNA^{Ser} will not function in protein synthesis.
- (B) Proteins synthesized using the alanyl-tRNA^{Ser} will contain neither alanine nor serine.
- (C) Proteins synthesized using the alanyl-tRNA^{Ser} will contain only serine where alanine would normally occur.
- (D) Proteins synthesized using the alanyl-tRNA^{Ser} will contain only alanine where serine would normally occur.
- (E) Proteins synthesized using the alanyl-tRNA^{Ser} will randomly contain either alanine or serine where serine would normally occur.

90. Which of the following matings between *E. coli* strains would result in a high frequency of transfer of chromosomal genes?

- (A) F⁺ × F⁺
- (B) F⁺ × F⁻
- (C) F⁻ × F⁻
- (D) Hfr × Hfr
- (E) Hfr × F⁻

91. In genetics, suppression of a mutation refers to

- (A) restoration of the original phenotype due to a second mutation
- (B) restoration of the original DNA sequence by mutation
- (C) prevention of expression of the mutant gene by metabolic regulation
- (D) appearance of the recessive phenotype in a heterozygous diploid
- (E) inactivation of the gene by methylation

Tissue	Factor A	Protein Kinase Activity	Protein Phosphatase Activity
Muscle	+	-	-
Heart	+	+	-
Brain	+	-	+

92. Transcription of gene X is controlled by transcription factor A. Gene X is only transcribed when factor A is phosphorylated. Data on the tissue distribution of factor A and the activities of a protein kinase and a protein phosphatase specific for factor A are presented in the table above. Of these three tissues, gene X will be transcribed in

- (A) muscle only
- (B) heart only
- (C) brain only
- (D) brain and heart only
- (E) muscle, heart, and brain

93. Which of the following pairs of compounds are interconvertible in the liver by a single polypeptide chain containing two different catalytic sites?
- (A) Glucose and glucose 6-phosphate
 (B) 3-Phosphoglycerate and phosphoenolpyruvate
 (C) Phosphoenolpyruvate and pyruvate
 (D) Fructose 6-phosphate and fructose 1,6-bisphosphate
 (E) Fructose 6-phosphate and fructose 2,6-bisphosphate
94. In terms of energy yield, phosphorylation is preferable to hydrolysis in the breakdown of glycogen or starch because
- (A) most phosphorylases have lower K_m values than do the corresponding phosphatases
 (B) glucose 1-phosphate yields more ATP than does free glucose when subsequently catabolized to pyruvate
 (C) the products of hydrolysis cannot be metabolized by the glycolytic pathway
 (D) the abundance of inorganic phosphate in the cell ensures that the reaction will function in the degradative and not the synthetic direction
 (E) the debranching process requires phosphorylated glucose residues
95. Which of the following six-membered ring compounds has the most planar structure?
- (A) Glucose
 (B) Cytosine
 (C) Cyclohexane
 (D) Inositol
 (E) Mannose
96. Substrate-level phosphorylation in the citric acid (Krebs) cycle depends directly on the energy of the
- (A) thioester bond of succinyl CoA
 (B) oxidative decarboxylation of isocitrate to α -ketoglutarate
 (C) formation of citrate from oxaloacetate and acetyl CoA
 (D) FAD-dependent oxidation of succinate to fumarate
 (E) phosphoanhydride bond of 1,3-bisphosphoglycerate

-
97. Two-dimensional (2-D) gel electrophoresis performed under denaturing conditions can be used to separate proteins according to which of the following characteristics?

<u>First Dimension</u>	<u>Second Dimension</u>
(A) Subunit molecular weight	Density
(B) Density	Charge
(C) Amino acid composition	Charge
(D) Isoelectric point (pI)	Subunit molecular weight
(E) Hydrophobicity	Subunit molecular weight

98. All of the following are known to involve a Ca^{2+} -activated, vesicle-mediated secretory event EXCEPT
- synaptic transmission
 - elevation of the fertilization membrane of the sea urchin
 - release of histamine from mast cells
 - sperm acrosomal reaction
 - constitutive secretion of collagen
99. A mutant cell whose cilia lack central pair microtubules and radial spokes would be unable to perform which of the following cilia-associated processes?
- ATP hydrolysis
 - Bend propagation (beating)
 - Outer doublet microtubule sliding
 - Ciliary regeneration
 - Proper length control
100. Labeling of mesoderm with vital dyes in the vertebrate embryo would result in labeling of which of the following adult tissues?
- Neural
 - Intestinal epithelial
 - Skeletal muscle
- I only
 - II only
 - III only
 - I and II
 - II and III
-
- Deletion 1: Genes *bde* are lost.
 Deletion 2: Genes *ac* are lost.
 Deletion 3: Genes *abd* are lost.
101. The genes *abcde* are determined to be closely linked on the *E. coli* chromosome. Three random short deletions are created in the region, resulting in the removal of various genes as shown above. Which of the following gene orders is possible based on the deletion analysis?
- abcde*
 - acbed*
 - bdeac*
 - cadbe*
 - eadcb*
102. Temperate bacteriophages differ from other bacteriophages in that temperate bacteriophages
- reproduce at moderate temperatures
 - inhibit synthesis of host-cell proteins
 - fragment the host-cell chromosome
 - can lysogenize the host cell
 - lyse the host cell
103. Which of the following is the most likely mechanism for the origin of multigene families?
- Endosymbiosis
 - Gene duplication
 - Convergent evolution of dissimilar genes
 - Horizontal gene transfer
 - Viral infection
104. Which of the following are found only in organisms containing polycistronic mRNA?
- Missense mutations
 - Polar mutations
 - Temperature-sensitive mutations
 - Alternative splicing sites
 - Deletion mutations
105. Which of the following is NOT required for RecA-dependent recombination between two DNA molecules?
- Strand migration
 - Ligation
 - Mismatch repair
 - Nuclease digestion
 - DNA synthesis
106. Which of the following occurs as a result of epinephrine binding to its receptor?
- cAMP is produced from AMP.
 - Glycogen accumulates.
 - Phosphorylase kinase is phosphorylated and glycogen synthase is dephosphorylated.
 - Phosphodiesterase is activated to prolong the effect of cAMP.
 - A phosphatase inhibitor is activated by phosphorylation.

107. Which of the following diagrams best describes the equilibria associated with a competitive inhibitor (I) ?

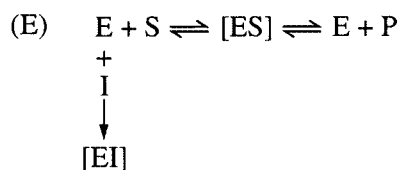
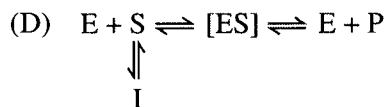
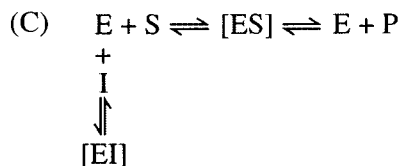
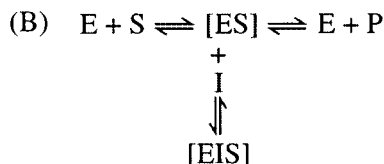
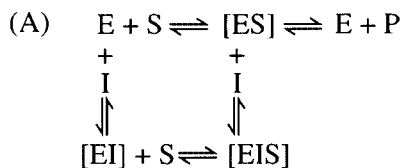

108. Hepatocytes are incubated for 2 hours in physiological medium containing 1 millimole of acetate with 500,000 disintegrations per minute (dpm) of $[1-^{14}\text{C}]$ acetate. If fatty acids extracted from the hepatocytes contain 5,000 dpm, what is the rate of incorporation of acetate into fatty acid, in micromoles per hour?

- (A) 1.25
- (B) 2.50
- (C) 5.00
- (D) 10.00
- (E) 20.00

109. Pyruvate kinase transfers a phosphate group from phosphoenolpyruvate to ADP, forming pyruvate and ATP. The reaction catalyzed by this enzyme is essentially irreversible. Which of the following is the best explanation for the irreversible nature of this reaction?

- (A) The binding of pyruvate to the active site is very weak relative to the binding of phosphoenolpyruvate.
- (B) The reaction is coupled to the pyruvate dehydrogenase reaction.
- (C) The hydrolysis of ATP is highly favorable.
- (D) The change in free energy ($\Delta G'$) for the overall reaction is large and negative.
- (E) There is a different enzyme in the cell which synthesizes phosphoenolpyruvate.

110. Activation of amino acids for peptide synthesis utilizes ATP, generating pyrophosphate, rather than P_i , as a product. The metabolic advantage of producing pyrophosphate rather than P_i is that

- (A) hydrolysis of the α - β phosphodiester linkage releases more energy than does hydrolysis of the β - γ linkage
- (B) ATP is readily resynthesized from the product AMP by the adenylate kinase reaction
- (C) subsequent pyrophosphate hydrolysis by pyrophosphatase pulls the reaction in favor of the product
- (D) the interaction of groups on the enzyme surface with the β phosphate as well as the γ phosphate makes removal of pyrophosphate faster
- (E) the pyrophosphate ion buffers over a wider range than phosphate

111. During cytokinesis in plant cells, the cell plate is formed by the fusion of vesicles derived from which of the following?

- (A) Microtubules
- (B) The Golgi complex
- (C) The contractile ring
- (D) The plasma membrane
- (E) The cell wall

112. Which of the following is NOT a property of the mammalian signal recognition particle (SRP) ?
- (A) It targets nascent secretory polypeptides to the rough endoplasmic reticulum.
 - (B) It temporarily arrests translation.
 - (C) It binds to the signal sequence of secretory proteins.
 - (D) It contains both RNA and several polypeptides.
 - (E) It contains a signal peptidase activity.
113. The ribosome is involved in all of the following EXCEPT
- (A) peptide bond formation
 - (B) aminoacylation of tRNA
 - (C) binding of protein factors during elongation
 - (D) binding of aminoacyl tRNA to mRNA
 - (E) binding of mRNA at an initiation codon
114. An *E. coli* strain lacking DNA polymerase I would be deficient in DNA
- (A) repair
 - (B) methylation
 - (C) splicing
 - (D) degradation
 - (E) transcription
115. In a mating between two strains of yeast that differ at a single locus (wild type \times mutant), 15 percent of the tetrads contain wild-type and mutant spores in the ratio of 3 : 1 or 1 : 3. The most likely explanation for this observation is
- (A) gene conversion
 - (B) deletion of the mutant allele
 - (C) allelic exclusion
 - (D) codominance
 - (E) reversion
116. The expression of the *trp* operon in *E. coli* is regulated in part by the availability of the amino acid tryptophan. This regulatory process is referred to as
- (A) attenuation
 - (B) translational read-through
 - (C) alternative splicing
 - (D) antitermination
 - (E) nonsense suppression
117. Which of the following types of information CANNOT be determined from the traditional Northern blotting technique?
- (A) The size of an mRNA species
 - (B) The half-life of an mRNA species
 - (C) The strand of DNA that is transcribed into mRNA
 - (D) The amino acid sequence of the protein coded by an mRNA species
 - (E) The relative levels of an mRNA species in different tissues
118. DNA sequence rearrangements are involved in all of the following processes EXCEPT
- (A) immunoglobulin gene expression in mammals
 - (B) transposition of bacteriophage Mu
 - (C) mating-type switching in yeast
 - (D) antigen switching in trypanosomes
 - (E) intron splicing in ciliates
119. Which of the following elements is LEAST likely to be found on any + strand viral genomic RNA?
- (A) A cap
 - (B) A packaging site
 - (C) A binding site for RNA-dependent RNA polymerase
 - (D) A binding site for ribosomes
 - (E) A binding site for RNA polymerase II

Directions: Each group of questions below consists of five lettered headings or labeled parts followed by a list of numbered words, phrases, or sentences. For each numbered word, phrase or sentence, select the one heading or labeled part that is most closely related to it and fill in completely the corresponding space on the answer sheet. Each heading or labeled part may be used once, more than once, or not at all in each group.

Questions 120-124 refer to the following substances.

- (A) NaCl
- (B) Glucose
- (C) Valine
- (D) Polyadenylate
- (E) Cholesterol

- 120. Largely insoluble in aqueous solutions
- 121. Highly soluble in water and solvated entirely by hydrogen bonding
- 122. Forms hydrated ion pairs in aqueous solutions
- 123. Exists largely as a zwitterion (dipolar ion) in aqueous solutions at neutral pH
- 124. Stabilized by base-stacking

Questions 125-129 refer to the following cell components in mammalian cells.

- (A) Nuclear envelope
- (B) Nucleolus
- (C) Euchromatin
- (D) Heterochromatin
- (E) Nuclear lamina

- 125. Site of synthesis of histone mRNA
- 126. Site of transcriptionally inactive DNA
- 127. Site of protein synthesis
- 128. Site of transcription by RNA polymerase II
- 129. Site of 45S rRNA processing

Questions 130-133 refer to the following schematic diagram of two normal chromosomes and five aberrant forms (A through E) of those chromosomes. (Circles represent centromeres and letters represent genetic loci.)

Normal Chromosomes

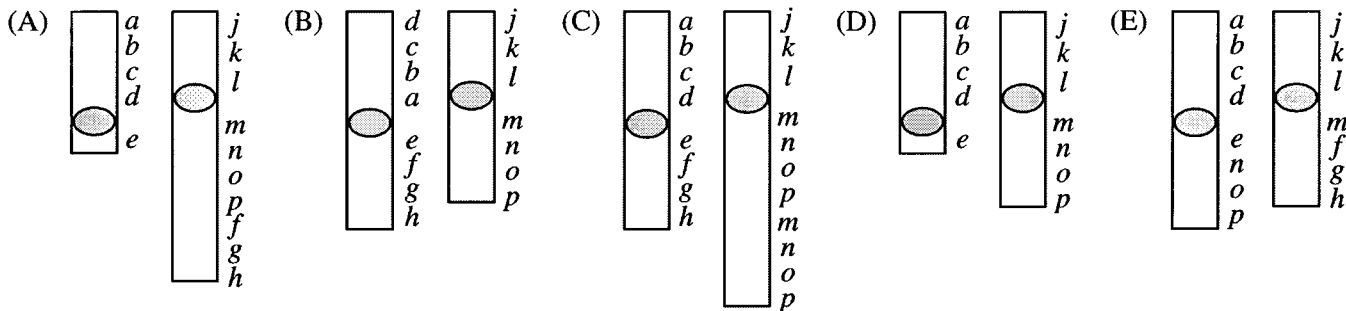
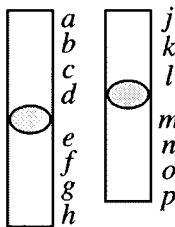

130. Duplication

131. Deletion

132. Reciprocal translocation

133. Inversion

Questions 134-136

The diagram illustrates a member of the beta-adrenergic family of receptors and the associated proteins and small molecules involved in its signaling pathway.

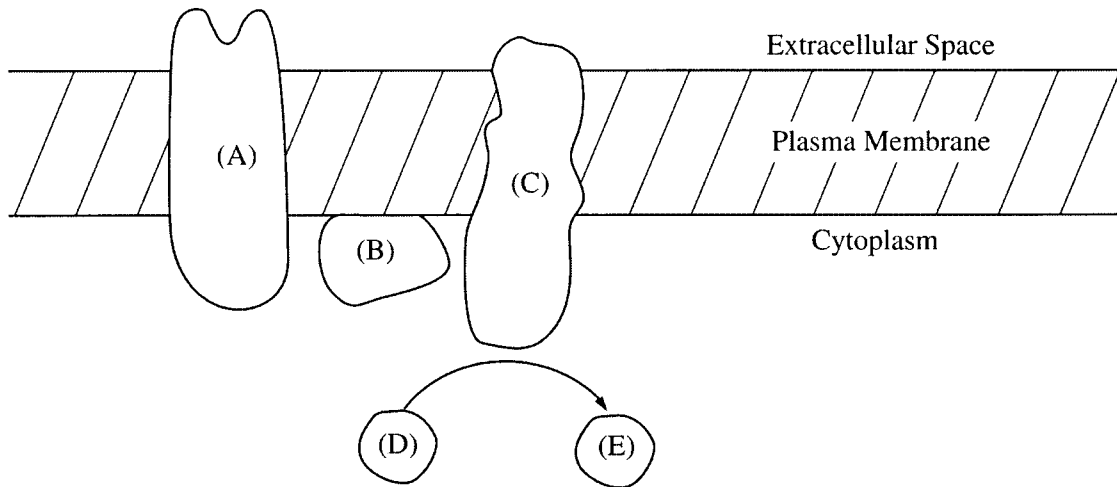

- 134. A heterotrimeric G protein
- 135. The molecule structurally and functionally related to rhodopsin
- 136. The enzyme whose physiological substrate is ATP

Questions 137-140 refer to the following enzymes.

- (A) Aconitase
- (B) Arginase
- (C) Catalase
- (D) Allantoinase
- (E) Asparaginase

- 137. A mammalian peroxisomal enzyme
- 138. A citric acid (Krebs) cycle enzyme
- 139. A urea cycle enzyme
- 140. An enzyme of purine nucleotide catabolism

Questions 141-145 refer to the following genetic terms.

- (A) Polygenic
- (B) Holandric
- (C) Polymorphic
- (D) Epistatic
- (E) Pleiotropic

- 141. A gene that segregates with maleness
- 142. A trait determined by the action of more than one gene
- 143. A gene that masks the expression of another gene
- 144. A gene that is present in a population in more than one form
- 145. A gene that has multiple phenotypic effects

Directions: Each group of questions below concerns a laboratory or an experimental situation. In each case, first study the description of the situation. Then choose the one best answer to each question and fill in completely the corresponding space on the answer sheet.

Questions 146-148

When normal human fibroblasts are cultured in medium containing calf serum, they divide with an average generation time of approximately 22 hours ($M = 1$ hr, $G_1 = 10$ hr, $S = 6$ hr, $G_2 = 5$ hr). To determine the effects of serum deprivation on cell cycle distribution, cells were incubated for 48 hours in medium with or without serum. At the end of this incubation, cells were harvested and stained with propidium iodide, which binds to DNA and fluoresces when exposed to ultraviolet light. The stained cells were analyzed for DNA content (fluorescence) in a flow cytometer. The results with serum are shown in Figure 1a. If deprived of serum, the cells stop proliferating and enter a quiescent state (Figure 1b).

In a second experiment, cells were deprived of serum for 48 hours and then treated either with serum alone or serum plus cycloheximide (CHX), an inhibitor of protein synthesis. At various times after treatment, RNA was isolated from the cells. Equal amounts of total cellular RNA from each sample were analyzed by gel electrophoresis and Northern blotting to detect the level of *c-fos* mRNA. The *c-fos* protein is involved in regulating cell proliferation. The results of this experiment are shown in Figure 2. (“-” indicates serum alone and “+” indicates serum plus CHX.)

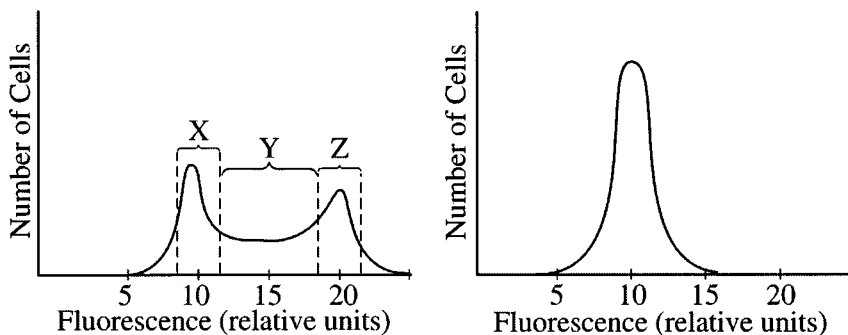

Figure 1a. With serum

Figure 1b. Without serum

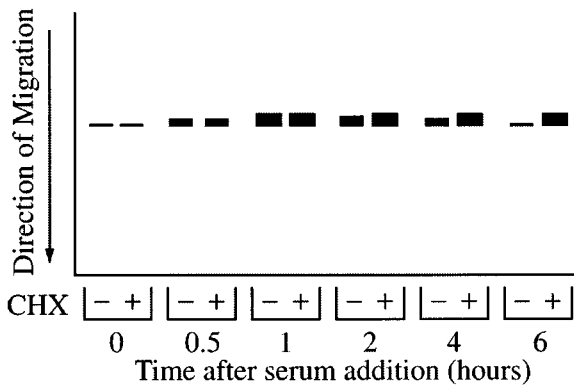

Figure 2. *c-fos* mRNA

146. In Figure 1a, the cells in the region labeled Y are in what stage of the cell cycle?
- (A) G₁
 - (B) S
 - (C) G₂
 - (D) M
 - (E) G₀
147. Cells growing in the presence of serum were labeled for 3 hours with ³H-thymidine and then analyzed by flow cytometry. Which of the following regions defined in Figure 1a will contain radioactive cells?
- (A) X only
 - (B) Y only
 - (C) Z only
 - (D) Y and Z only
 - (E) X, Y, and Z
148. Based on the results shown in Figure 2, the differences in the amounts of *c-fos* mRNA in the presence *versus* the absence of cycloheximide at 2, 4, and 6 hours is best explained by which of the following?
- (A) *c-fos* mRNA is degraded by an unstable nuclease.
 - (B) The *c-fos* promoter is regulated by an unstable transcriptional activator.
 - (C) The *c-fos* protein activates its own promoter.
 - (D) Splicing of *c-fos* pre-mRNA requires an unstable splicing factor.
 - (E) *c-fos* mRNA is degraded by cycloheximide-induced nuclease.

Questions 149-151

The levels of incorporation of amino acids in an *in vitro* translation system under the direction of random adenosine (A) : cytosine (C) copolymers of two types, A : C = 5 : 1 and A : C = 1 : 5, were determined, and the results are shown below. The most frequently incorporated amino acid for each type of copolymer is given a value of 100. This value is then used to calculate relative incorporation of the other amino acids.

<u>Amino Acid</u>	<u>Incorporation of Amino Acids for A : C = 5 : 1</u>	<u>Incorporation of Amino Acids for A : C = 1 : 5</u>
Asparagine	24.2	5.3
Glutamine	23.7	5.2
Histidine	6.5	23.4
Lysine	100	1.0
Proline	7.2	100
Threonine	26.5	20.8

149. The expected frequency of the triplet AAA in the A : C = 5 : 1 copolymer should be

- (A) 1/8
- (B) 5/6
- (C) 7/8
- (D) 15/216
- (E) 125/216

150. Which of the following pairs of amino acids appear to be coded by triplets containing 2 A's and 1 C ?

- (A) Asparagine and glutamine
- (B) Asparagine and histidine
- (C) Histidine and threonine
- (D) Lysine and glutamine
- (E) Proline and histidine

151. The incorporation data for amino acids indicate that

- (A) each base triplet must code for a different amino acid
- (B) some triplets can code for more than one amino acid
- (C) some amino acids can be coded by more than one triplet
- (D) each amino acid can be coded by two or more triplets
- (E) the copolymers must contain some noncoding triplets

Questions 152-154

In order to study the activity of enzyme X, cells were treated with either glucagon, dibutyryl cAMP, or glucagon plus H-8 at doses required to achieve a maximal effect. The activity and concentration of enzyme X were then assayed in dilute cell-free extracts. Dibutyryl cAMP is an analog of cAMP that diffuses across cell membranes more easily than does cAMP itself. H-8 is a selective inhibitor of protein kinase A. The results are shown in the following table.

<u>Agent Added</u>	<u>Enzyme Activity</u> (units)	<u>Enzyme Concentration</u> (micrograms per mL)
None	10	10
Glucagon	100	12
Dibutyryl cAMP	100	9
Glucagon plus H-8	18	11

152. It can be inferred from these results that glucagon most likely acts to
- (A) cause translocation of enzyme X to the lysosomes
 - (B) increase the catalytic efficiency of enzyme X
 - (C) inhibit degradation of enzyme X
 - (D) stimulate transcription of the gene for enzyme X
 - (E) stimulate increased intracellular production of the substrate for enzyme X
153. It can be inferred from these results that the changes in activity of enzyme X are mediated by
- (A) allosteric interaction of an intermediary protein with H-8
 - (B) proteolytic cleavage of an intermediary protein
 - (C) a phosphorylation, probably catalyzed by protein kinase A
 - (D) a dephosphorylation, probably catalyzed by protein phosphatase 1A
 - (E) a cAMP-independent signaling pathway
154. Which of the following additional pieces of experimental information would be most useful in elucidating the mechanism of action of glucagon?
- (A) Rate of transcription of the gene for enzyme X
 - (B) Rate of covalent incorporation of $^{32}\text{P}_i$ into enzyme X
 - (C) Rate of covalent incorporation of ^{35}S methionine into enzyme X
 - (D) Translational efficiency of the mRNA for enzyme X
 - (E) Binding constant of H-8 for purified enzyme X

Questions 155-157

In a study of the biosynthesis of a particular secretory glycoprotein, the first step was to fractionate a crude RNA extract using an oligo-dT column. The RNA bound to the column was eluted and translated *in vitro* in the presence of [^3H]leucine and [^{14}C]mannose. An antibody specific for the secretory glycoprotein was added and the resulting immunoprecipitate was analyzed by sodium dodecyl sulfate (SDS) polyacrylamide gel electrophoresis. Distribution of radioactivity as a function of position in the gel was then analyzed as shown in Figure 1. The *in vitro* translation experiment was repeated in the presence of rough microsomes, which were then solubilized. Immunoprecipitation and electrophoresis were performed as in the previous experiment. The results are shown in Figure 2.

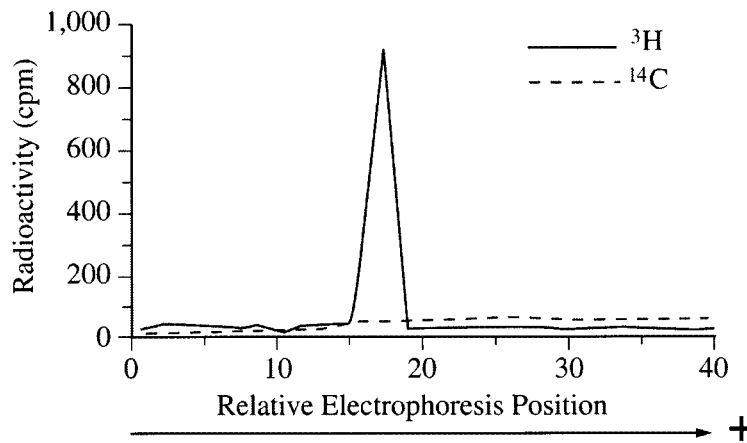

Figure 1
Without Microsomes

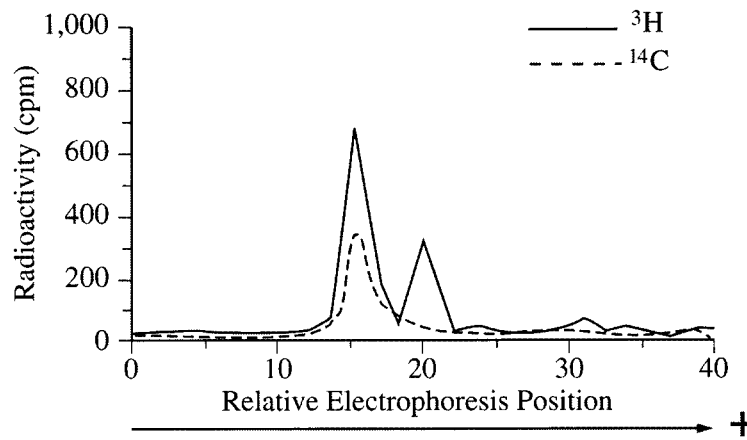

Figure 2
With Microsomes

155. Why is the oligo-dT column used in this experiment?
- (A) Only hnRNA will bind to oligo-dT.
 - (B) Oligo-dT selects large RNA species.
 - (C) Ribosomal RNA is bound to the column.
 - (D) Intact, rather than partially hydrolyzed, RNA is retained on the column.
 - (E) Polyadenylated RNA is purified by the procedure.
156. The protein in the peak of ^3H at position 20 in Figure 2 is of lower monomeric molecular weight than the protein in Figure 1. This suggests that microsomes cause proteolysis but only one of the products of proteolysis appears on the gel in Figure 2. All of the following can account for the absence of a second product of proteolysis EXCEPT:
- (A) It was not recognized by the antiserum.
 - (B) It contains no leucine or mannose residues.
 - (C) It was bound by, but not released from, the oligo-dT column.
 - (D) It was rapidly degraded.
 - (E) It was too small to be retained on this gel.
157. If glycosylation were blocked with tunicamycin in the experiment with microsomes, the resulting gel would display only ^3H -leucine labeling and most likely show which of the following characteristic profiles?
- (A) The same as Figure 1
 - (B) Two peaks of radiolabel, one centered at position 15 and one centered at position 20
 - (C) Two peaks of radiolabel, one centered at position 20 and the other, twice the amplitude, centered at position 24
 - (D) A single peak of radiolabel centered at position 20
 - (E) A single peak of radiolabel centered at position 15

Questions 158-160

An *in vitro* system is used to study replication of a viral DNA genome that is a double-stranded, covalently closed circle. The location of the sites for the restriction endonuclease *Mbo*I on this DNA are shown in Figure 1. Replication reactions are carried out using viral DNA as a template, extracts of infected cells as a source of enzymes, and other exogenous nucleotides (dGTP, dCTP, dATP, dTTP, and ATP), all of which are labeled with ^{32}P . The reaction products are digested with *Mbo*I, analyzed by agarose gel electrophoresis, and visualized by autoradiography, producing the results shown in lane 1 of Figure 2. The same reaction is carried out in the presence of increasing concentrations of nonradioactive 2', 3'-dideoxyGTP (ddGTP), and the results are shown in lanes 2-4. (Note: only full-length restriction fragments are shown.)

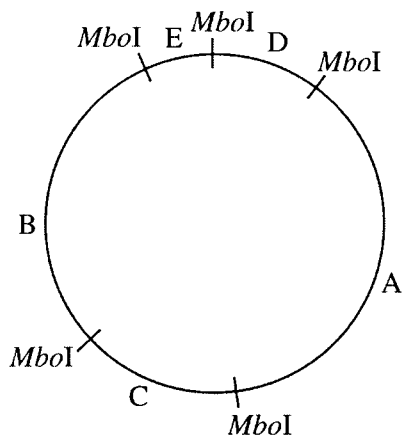

Figure 1

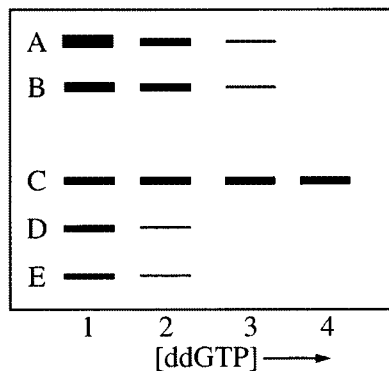

Figure 2

158. The specific activity of the DNA fragments in Figure 2 is defined as ^{32}P disintegrations per minute per microgram of DNA. Which of the following best describes the relative specific activities of the fragments in lane 1?
- (A) Fragment A has the highest specific activity, followed by B, C, D and E.
 - (B) Fragment E has the highest specific activity, followed by D, C, B, and A.
 - (C) The specific activity depends on the order in which the fragments were replicated.
 - (D) All fragments have the same specific activity.
 - (E) The relative specific activities vary from experiment to experiment.
159. The data in Figure 2 indicate that the origin of replication of this DNA is in fragment
- (A) A
 - (B) B
 - (C) C
 - (D) D
 - (E) E
160. The data in Figure 2 indicate that replication of this DNA is
- (A) unidirectional
 - (B) bidirectional
 - (C) rolling circle
 - (D) conservative
 - (E) semiconservative

Questions 161-163

The protein α_1 -antitrypsin (α_1 AT) inhibits the action of the proteolytic enzyme elastase in lung tissue. A mutation has been described in which the only change is the substitution of an Arg residue for a Met residue in α_1 AT. The altered α_1 AT does not inhibit elastase but has the new property of inhibiting the blood coagulation protein thrombin. The sequences around the active site of α_1 AT, altered α_1 AT, and the natural thrombin inhibitor (antithrombin) are given below.

α_1 AT	... <i>Met Ser Ile Pro Pro Glu</i> ...
Altered α_1 AT	... <i>Arg Ser Ile Pro Pro Glu</i> ...
Antithrombin	... <i>Arg Ser Leu Asn Pro Asn</i> ...

161. Which of the following would be the best method to separate α_1 AT from altered α_1 AT ?
- (A) Size-exclusion chromatography
 - (B) Ion-exchange chromatography
 - (C) Thin-layer chromatography
 - (D) Sucrose-gradient centrifugation
 - (E) SDS-polyacrylamide gel electrophoresis
162. From the information given, all of the following can correctly be concluded EXCEPT:
- (A) The number of trypsin cleavage sites is greater in altered α_1 AT than in α_1 AT.
 - (B) The number of cyanogen bromide cleavage sites is greater in α_1 AT than in altered α_1 AT.
 - (C) Individuals with the mutation described might have a bleeding disorder.
 - (D) Antithrombin differs from α_1 AT only at the active site.
 - (E) Single-residue changes in proteins can alter substrate-binding specificities.
163. Smokers' lungs are often damaged by elastase because the α_1 AT is inactive. The best explanation for this effect is that tobacco smoke
- (A) causes the substitution of Met for Arg in α_1 AT
 - (B) causes the substitution of Asn for Pro in α_1 AT
 - (C) contains oxidants, which chemically modify the Met in α_1 AT
 - (D) contains carbon monoxide, which competes with α_1 AT for binding to elastase
 - (E) contains nicotine, which serves as a cofactor for elastase

Questions 164-166

An experimenter generates a library of plasmids containing 10-15 kilobase (kb) inserts from the genome of a bacterium by partially digesting the bacterial genomic DNA with *EcoRI* and cloning the resulting fragments into the *EcoRI* site of a plasmid vector. The experimenter must then identify the plasmids containing the *purB* gene. To do this, 5 of the plasmids from the library were digested with *EcoRI* and the digests were separated by gel electrophoresis (Figure 1). In a second experiment, the same 5 plasmids were analyzed by PCR using primers derived from sequences internal to *purB* and electrophoresis was performed on the PCR products (Figure 2). Both gels were stained with ethidium bromide to visualize the DNA.

Figure 1. Electrophoresis of digests

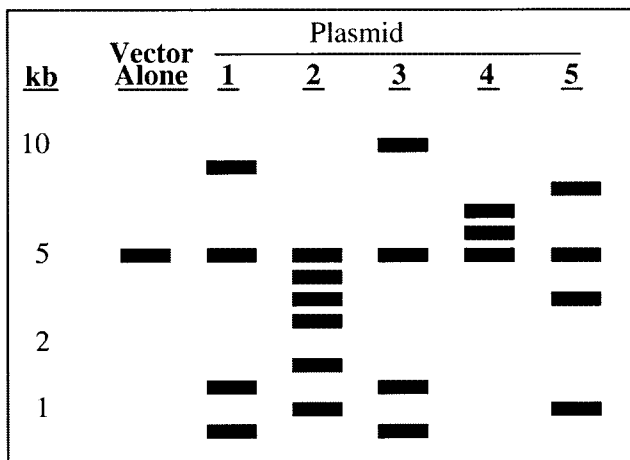
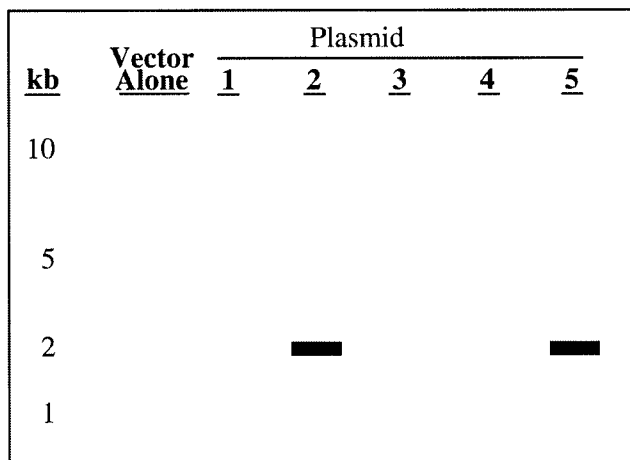

Figure 2. Electrophoresis of PCR products



164. The inserts in which of the following pairs of plasmids may overlap?
- (A) 3 with 4 only
 - (B) 3 with 5 only
 - (C) 1 with 2 and 3 with 4 only
 - (D) 1 with 3 and 2 with 5 only
 - (E) All of the inserts may overlap.
165. Which of the following methods would NOT be a useful alternative to using PCR to determine which plasmids contain *purB* ?
- (A) Testing for complementation of a *purB* auxotroph
 - (B) Sequencing the inserts
 - (C) Hybridizing the plasmids with a probe complementary to *purB*
 - (D) Mapping each plasmid with several restriction enzymes
 - (E) Footprinting with DNase

166. The part of *purB* complementary to the *purB* primers is contained in which of the following plasmids?
- (A) 2 only
 - (B) 5 only
 - (C) 2 and 5 only
 - (D) 1, 3, and 4 only
 - (E) 1, 2, 3, 4, and 5

Questions 167-170

The table below shows the effects of various treatments on the *in vitro* proliferation of cartilage, fibroblast, and hepatoma cells. The different treatments in the experiment were as follows: none (i.e., control), epidermal growth factor (EGF), liver-cell growth factor (LCGF), recombinant retrovirus carrying the oncogene *v-erbB* (retrovirus), and antibody raised against the EGF receptor (receptor antibody). (Note: The amino acid sequence of the protein encoded by *v-erbB* is closely related to that of the EGF receptor.)

INDUCTION OF CELLULAR PROLIFERATION

Treatment	Cell Type		
	Cartilage	Fibroblast	Hepatoma
Control	+	+	+
EGF	+++	+++	+
LCGF	+	+++	+++
Retrovirus	+++++	+++++	+
Receptor antibody	+++	+++	+

(Increasing numbers of +’s indicate increasing cell proliferation.)

167. Which of the following statements about the EGF and LCGF treatments is LEAST likely?
- (A) Some cell types have receptors for more than one growth factor.
 - (B) Hepatoma cells have an LCGF receptor but not an EGF receptor.
 - (C) EGF and LCGF trigger growth by binding with different affinities to the same receptor.
 - (D) Growth factors show some specificity regarding target cell type.
 - (E) Both normal and tumor cells can respond to growth factors.

168. Cultured fibroblasts were labeled with ³²P-ortho-phosphate. Subsequent EGF treatment increased the radioactivity detected in a small subset of total cell proteins. Which of the following best explains this finding?
- (A) EGF acts as a protein phosphatase.
 - (B) EGF activates a protein kinase.
 - (C) EGF activates an ATPase.
 - (D) EGF is phosphorylated.
 - (E) The activated receptor acts as a protein phosphatase.

169. When the divalent antibody was made monovalent by separating the antigen-binding domains (Fabs) from the constant domain (F_c), the Fab portion, but not the F_c portion, bound the EGF receptor. Neither portion triggered cell proliferation. Which of the following conclusions is best supported by these results?
- (A) EGF binds a divalent antibody but not a monovalent antibody.
 - (B) Signal transduction requires EGF or a monovalent antibody.
 - (C) Binding of the Fab portion alone leads to internalization of the receptor.
 - (D) Only a divalent antibody recognizes the binding site for EGF.
 - (E) Dimerization of EGF receptors by a divalent antibody leads to signal transduction.
170. Which of the following accounts for the extent of proliferation observed in the retrovirus-infected cells not treated with growth factors?
- (A) The *v-erbB* product has a function similar to that of activated EGF receptor.
 - (B) EGF binds to both the EGF receptor and the *v-erbB* product.
 - (C) The *v-erbB* product activates both the LCGF and the EGF receptors.
 - (D) The *v-erbB* product antagonizes the action of the EGF receptor.
 - (E) The *v-erbB* product induces secretion of EGF and LCGF.

Questions 171-173

Muscle cells were incubated in the presence of O_2 and then quickly made anoxic. The concentrations of various metabolites were measured immediately following the removal of O_2 . The results are shown in the figure below.

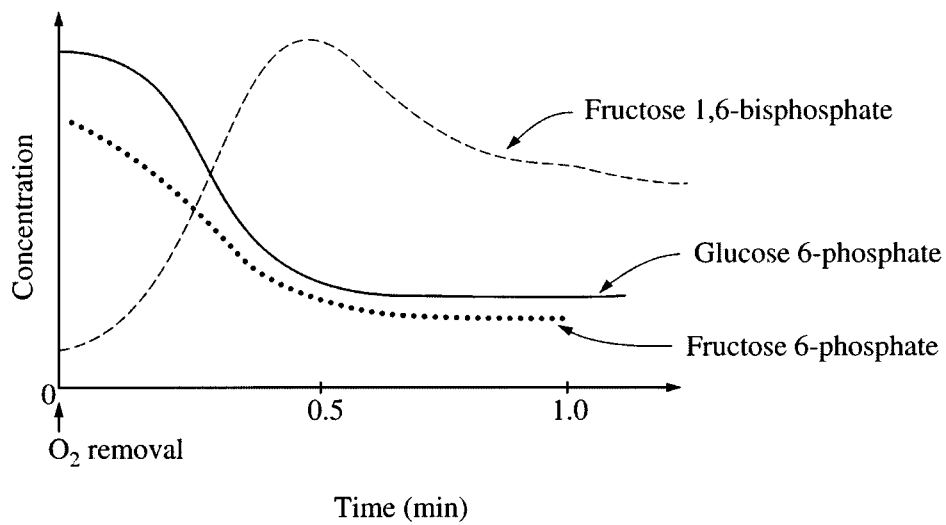

171. The change in the glucose 6-phosphate concentration can be explained best by which of the following?
- (A) Increased synthesis of glycogen
 - (B) Increased conversion to free glucose
 - (C) Increased rate of glycolysis
 - (D) Decreased synthesis of glucose 6-phosphate
 - (E) Acceleration of the citric acid (Krebs) cycle
172. The initial increase in the concentration of fructose 1,6-bisphosphate is most likely due to
- (A) activation of gluconeogenesis
 - (B) activation of phosphofructokinase
 - (C) inhibition of the citric acid (Krebs) cycle
 - (D) inhibition of aldolase
 - (E) increase in the concentration of ATP
173. Which of the following is most likely to happen to the concentration of lactate in the cell?
- (A) It will remain the same.
 - (B) It will increase initially and then decrease to control values as equilibrium is achieved.
 - (C) It will increase to a new steady-state level.
 - (D) It will decrease because the cell secretes the lactate.
 - (E) It will decrease because the cell uses lactate to synthesize glucose.

Questions 174-177

Researchers studying the regulation of a hormone-responsive gene isolated 750 base pairs of DNA immediately preceding the start site of transcription (+1). They demonstrated that if these sequences are cloned upstream of the bacterial chloramphenicol acetyltransferase (CAT) gene and the DNA then introduced into mammalian cells, CAT enzyme activity increases in response to hormone treatment. To define the sequences involved in the regulation of this gene, they made a series of deletions containing various lengths of the 5' regulatory sequences. They cloned these truncated DNA fragments upstream of the CAT gene as shown in the figure below, introduced the constructs into mammalian cells, and assayed for CAT enzyme activity in the absence (-) and presence (+) of hormone. The figure below gives the results of a representative experiment.

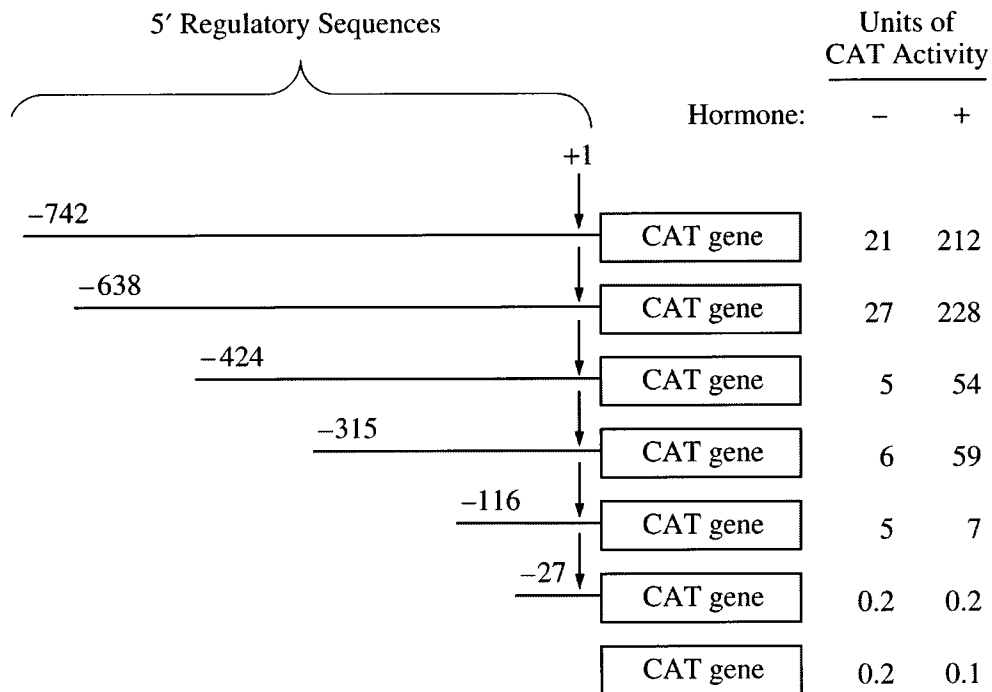

174. Assuming that there is a single hormone-responsive regulatory element in the gene, that element is located between
- (A) -742 and -638
 - (B) -638 and -424
 - (C) -424 and -315
 - (D) -315 and -116
 - (E) -116 and -27
175. The maximal stimulation of CAT activity due to the addition of hormone is approximately
- (A) 4-fold
 - (B) 10-fold
 - (C) 40-fold
 - (D) 100-fold
 - (E) 1,000-fold
176. Which of the following statements is NOT supported by the data?
- (A) The bacterial CAT gene requires eukaryotic regulatory elements for significant expression in mammalian cells.
 - (B) Gene expression in the presence *versus* the absence of regulatory elements can differ by as much as a 1,000-fold.
 - (C) Hormone-independent regulatory elements lie downstream of -315.
 - (D) Hormone-independent regulatory elements lie upstream of -315.
 - (E) Regulatory elements probably do not lie upstream of -742.
177. A new construct was made that began at -742 and was identical to that shown in the figure except that the sequences between -424 and -315 were inverted. In this new construct, which of the following are closest to the expected CAT activities in the absence and presence, respectively, of hormone?
- (A) 25 units/250 units
 - (B) 25 units/25 units
 - (C) 50 units/50 units
 - (D) 5 units/50 units
 - (E) 5 units/5 units

Questions 178-180

Eukaryotic cell membranes were analyzed for hormone receptors. A membrane preparation was incubated with radiolabeled hormone (^3H -hormone) for five minutes. A similar incubation of membranes and ^3H -hormone contained, in addition, a 1,000-fold excess of unlabeled hormone. In both cases, the unbound hormone was removed by washing the preparation and the amount of radioactivity remaining in the membrane preparation was determined. The following results were obtained.

<u>^3H-hormone Only</u>	<u>^3H-hormone plus Excess Unlabeled Hormone</u>
5,000 cpm	1,500 cpm

178. Which of the following statements is most likely true concerning the binding of ^3H -hormone?
- (A) The total amount of radioactivity bound in the absence of unlabeled hormone represents the amount bound by the receptors.
 - (B) Most of the label is bound nonspecifically.
 - (C) The unlabeled hormone competes with ^3H -hormone for binding to the receptors.
 - (D) The cpm bound in the absence of unlabeled hormone minus the cpm bound in the presence of unlabeled hormone is a measure of nonspecific binding.
 - (E) In the presence of unlabeled hormone, the only radioactivity detected is that of the ^3H -hormone-receptor complex.

179. Having established the optimal conditions to measure the specific binding of the hormone to its receptor, the experiment was repeated using a constant amount of membrane but varying the concentration of ^3H -hormone. Which of the following graphs best depicts the expected results?

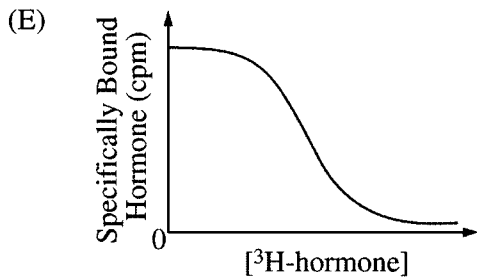
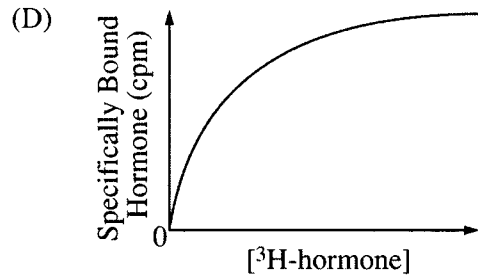
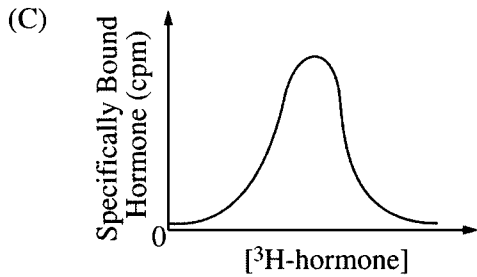
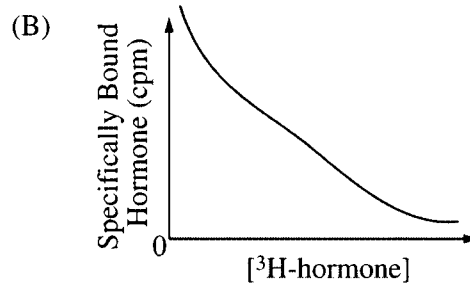
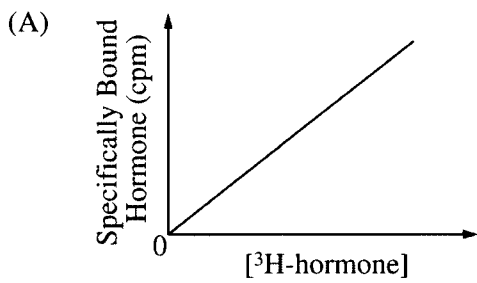

180. If the membrane preparation is incubated prior to the assay with GTP or GTP- γS (a nonhydrolyzable analog of GTP), the binding affinity decreases. That is, a higher concentration of ^3H -hormone is needed to obtain the maximal amount of specific binding. Which of the following best explains these results?

- (A) A G protein modulates the affinity of the receptor for the hormone.
- (B) Hydrolysis of GTP causes decreased affinity of the receptor for the hormone.
- (C) A GTP-dependent protease is present in the preparation.
- (D) The receptor directly interacts with adenylate cyclase.
- (E) GTP inhibits the binding of cAMP to the receptor.

If you finish before time is called, you may check your work on this test.

NOTE: To ensure prompt processing of test results, it is important that you fill in the blanks exactly as directed.

SUBJECT TEST

A. Print and sign your full name in this box:

PRINT: _____
 (LAST) (FIRST) (MIDDLE)

SIGN: _____

Copy this code in box 6 on your answer sheet. Then fill in the corresponding ovals exactly as shown.

6. TITLE CODE				
2	2	3	6	5
0	0	0	0	0
1	1	1	1	1
●	●	2	2	2
3	3	●	3	3
4	4	4	4	4
5	5	5	5	●
6	6	6	●	6
7	7	7	7	7
8	8	8	8	8
9	9	9	9	9

Copy the Test Name and Form Code in box 7 on your answer sheet.

TEST NAME Biochemistry, Cell and Molecular Biology

FORM CODE GR0022

GRADUATE RECORD EXAMINATIONS SUBJECT TEST

B. The Subject Tests are intended to measure your achievement in a specialized field of study. Most of the questions are concerned with subject matter that is probably familiar to you, but some of the questions may refer to areas that you have not studied.

Your score will be determined by subtracting one-fourth the number of incorrect answers from the number of correct answers. Questions for which you mark no answer or more than one answer are not counted in scoring. If you have some knowledge of a question and are able to rule out one or more of the answer choices as incorrect, your chances of selecting the correct answer are improved, and answering such questions will likely improve your score. It is unlikely that pure guessing will raise your score; it may lower your score.

You are advised to use your time effectively and to work as rapidly as you can without losing accuracy. Do not spend too much time on questions that are too difficult for you. Go on to the other questions and come back to the difficult ones later if you can.

YOU MUST INDICATE ALL YOUR ANSWERS ON THE SEPARATE ANSWER SHEET. No credit will be given for anything written in this examination book, but you may write in the book as much as you wish to work out your answers. After you have decided on your response to a question, fill in the corresponding oval on the answer sheet. BE SURE THAT EACH MARK IS DARK AND COMPLETELY FILLS THE OVAL. Mark only one answer to each question. No credit will be given for multiple answers. Erase all stray marks. If you change an answer, be sure that all previous marks are erased completely. Incomplete erasures may be read as intended answers. Do not be concerned that the answer sheet provides spaces for more answers than there are questions in the test.

Example:

What city is the capital of France?

- (A) Rome
- (B) Paris
- (C) London
- (D) Cairo
- (E) Oslo

Sample Answer

- (A) ● (C) (D) (E)
- (A) ~~B~~ (C) (D) (E)
- (A) ~~B~~ (C) (D) (E)
- (A) ● (C) (D) (E)
- (A) ~~B~~ (C) (D) (E)

CORRECT ANSWER PROPERLY MARKED

IMPROPER MARKS

DO NOT OPEN YOUR TEST BOOK UNTIL YOU ARE TOLD TO DO SO.



Educational Testing Service
 Princeton, New Jersey 08541

Scoring Your Subject Test

Biochemistry, Cell and Molecular Biology Test scores typically range from 400 to 680. The range for different editions of a given test may vary because different editions are not of precisely the same difficulty. The differences in ranges among different editions of a given test, however, usually are small. This should be taken into account, especially when comparing two very high scores. In general, differences between scores at the 99th percentile should be ignored. **The score conversion table on page 57 shows the score range for this edition of the test only.**

Subscores are reported as two-digit scaled scores. The maximum possible range of Subject Test subscores is 20 to 99. Like total scores, the actual range of subscores for any test or test edition may be smaller than 20 to 99.

The worksheet on page 56 lists the correct answers to the questions. Columns are provided for you to mark whether you chose the correct (C) answer or an incorrect (I) answer to each question. Draw a line across any question you omitted, because it is not counted in the scoring. At the bottom of the page, enter the total number correct and the total number incorrect. Divide the total incorrect by 4 and subtract the resulting number from the total correct. This is the adjustment made for guessing. Then round the result to the nearest whole number. This will give you your raw total score. Use the total score conversion table to find the scaled total score that corresponds to your raw total score.

Example: Suppose you chose the correct answers to 91 questions and incorrect answers to 39. Dividing 39 by 4 yields 9.8. Subtracting 9.8 from 91 equals 81.2, which is rounded to 81. The raw score of 81 corresponds to a scaled score of 530.

The subscore columns in the worksheet can be similarly used to tally your correct and incorrect responses to the questions that contribute to each subscore. We suggest that you circle the “●” if you chose the correct answer, and put a minus sign beside the “●” for an incorrect answer. Space is provided at the bottom right of the worksheet to calculate and enter your three raw subscores. The subscore conversion table will show you the scaled subscores that correspond to your raw subscores.

**Worksheet for the Biochemistry, Cell and Molecular Biology Test, Form GR0022
Answer Key and Percentages* of Examinees Answering Each Question Correctly**

QUESTION Number	Answer	P +	TOTAL		SUBSCORE		
			C	I	1	2	3
1	D	76			•		
2	A	28			•		
3	B	34			•		
4	A	65			•		
5	E	80			•		
6	A	63				•	
7	E	79				•	
8	B	42				•	
9	D	84				•	
10	B	54				•	
11	E	41					•
12	E	61					•
13	E	47					•
14	C	80					•
15	C	79					•
16	D	56			•		
17	C	38			•		
18	B	76			•		
19	D	51			•		
20	A	47			•		
21	E	65				•	
22	D	6				•	
23	E	46				•	
24	D	63				•	
25	A	11				•	
26	A	57					•
27	B	79					•
28	E	67					•
29	D	83					•
30	A	76					•
31	B	32			•		
32	C	30			•		
33	E	84			•		
34	E	33			•		
35	B	74			•		
36	B	63				•	
37	E	60				•	
38	D	20				•	
39	A	59				•	
40	B	25				•	
41	A	43					•
42	A	61					•
43	D	48					•
44	C	46					•
45	D	77					•
46	B	50			•		
47	A	53			•		
48	E	8			•		
49	E	60			•		
50	B	63			•		
51	A	27			•		
52	C	57				•	
53	D	36				•	
54	A	43				•	
55	D	38				•	
56	C	59					•
57	D	41					•
58	B	65					•
59	A	45					•
60	D	5					•

QUESTION Number	Answer	P +	TOTAL		SUBSCORE		
			C	I	1	2	3
61	D	52			•		
62	C	72			•		
63	A	50			•		
64	E	50			•		
65	A	24			•		
66	A	71				•	
67	A	22				•	
68	C	45				•	
69	D	59				•	
70	E	66					•
71	E	51					•
72	C	54					•
73	B	91					•
74	E	45					•
75	B	54					•
76	B	43					•
77	C	40			•		
78	B	35			•		
79	E	83			•		
80	C	61			•		
81	B	47			•		
82	B	46			•		
83	B	23			•		
84	B	30			•		
85	C	62				•	
86	D	43			•		
87	D	58			•		
88	B	42					•
89	D	75					•
90	E	51					•
91	A	57					•
92	B	81					•
93	E	12			•		
94	B	32			•		
95	B	32			•		
96	A	35			•		
97	D	62			•		
98	E	47				•	
99	B	55				•	
100	C	36				•	
101	D	78					•
102	D	45					•
103	B	58					•
104	B	26					•
105	C	28					•
106	E	6			•		
107	C	77			•		
108	C	33			•		
109	D	63			•		
110	C	52			•		
111	B	32				•	
112	E	30				•	
113	B	69				•	
114	A	83					•
115	A	23					•
116	A	82					•
117	D	47					•
118	E	34					•
119	E	23					•
120	E	89			•		

QUESTION Number	Answer	P +	TOTAL		SUBSCORE		
			C	I	1	2	3
121	B	63			•		
122	A	81			•		
123	C	75			•		
124	D	73			•		
125	C	20				•	
126	D	56				•	
127	A	31				•	
128	C	37				•	
129	B	48				•	
130	C	93					•
131	D	96					•
132	E	88					•
133	B	90					•
134	B	57				•	
135	A	50				•	
136	C	62				•	
137	C	70			•		
138	A	65			•		
139	B	29			•		
140	D	18			•		
141	B	62					•
142	A	75					•
143	D	64					•
144	C	69					•
145	E	54					•
146	B	38				•	
147	D	27				•	
148	A	25				•	
149	E	41					•
150	A	53					•
151	C	56					•
152	B	50			•		
153	C	59			•		
154	B	26			•		
155	E	58				•	
156	C	46				•	
157	D	14				•	
158	D	26					•
159	C	77					•
160	B	56					•
161	B	67			•		
162	D	51			•		
163	C	47			•		
164	D	50					•
165	E	43					•
166	C	82					•
167	C	60				•	
168	B	49				•	
169	E	46				•	
170	A	48				•	
171	C	49			•		
172	B	38			•		
173	C	51			•		
174	D	29					•
175	B	71					•
176	E	28					•
177	A	33					•
178	C	62			•		
179	D	82			•		
180	A	66			•		

Total Correct (C) _____

Total Incorrect (I) _____

Total Score: _____

C - I/4 = _____

Scaled Score (SS) = _____

Subscores:

1) C - I/4 = _____ SS = _____

2) C - I/4 = _____ SS = _____

3) C - I/4 = _____ SS = _____

*The P+ column indicates the percentage of Biochemistry, Cell and Molecular Biology Test examinees that answered each question correctly; it is based on a sample of December 2000 examinees selected to represent all Biochemistry, Cell and Molecular Biology Test examinees tested between October 1, 1997, and September 30, 2000.

**Score Conversions for GRE Biochemistry,
Cell and Molecular Biology Test
Form GR0022 and the Percents Below***

TOTAL SCORE					
Raw Score	Scaled Score	%	Raw Score	Scaled Score	%
180	860	99	88-90	560	60
178-179	850	99	85-87	550	57
174-177	840	99	82-84	540	53
171-173	830	99	79-81	530	50
168-170	820	99	76-78	520	46
165-167	810	99	73-75	510	43
162-164	800	99	70-72	500	39
159-161	790	99	67-69	490	36
156-158	780	99	64-66	480	32
153-155	770	99	61-63	470	29
150-152	760	99	57-60	460	26
147-149	750	98	54-56	450	23
144-146	740	97	51-53	440	21
141-143	730	97	48-50	430	18
138-140	720	96	45-47	420	15
134-137	710	95	42-44	410	13
131-133	700	94	39-41	400	11
128-130	690	92	36-38	390	9
125-127	680	91	33-35	380	7
122-124	670	89	30-32	370	6
119-121	660	87	27-29	360	4
116-118	650	85	24-26	350	3
113-115	640	83	21-23	340	3
110-112	630	80	17-20	330	2
107-109	620	78	14-16	320	1
104-106	610	75	11-13	310	1
101-103	600	73	8-10	300	1
98-100	590	70	5-7	290	1
94-97	580	67	2-4	280	1
91-93	570	64	0-1	270	1

**Score Conversions for GRE Biochemistry,
Cell and Molecular Biology Test Subscores
(Use for Form GR0022)**

SUBSCORES								
Raw Scores	Raw Scores			Scaled Score	Raw Scores			Scaled Score
	Sub 1	Sub 2	Sub 3		Sub 1	Sub 2	Sub 3	
64-65	50			83	29	20	34	54
63	49			82	28	19	33	53
62	48			81	27	18	32	52
61	47	65		80	26	17	31	51
60	46	64		79	24-25	16	29-30	50
58-59	45	63		78	23	15	28	49
57	44	62		77	22	14	27	48
56	43	61		76	21	13	26	47
55	42	59-60		75	20	12	25	46
53-54	41	58		74	18-19	11	23-24	45
52	40	57		73	17	10	22	44
51	39	56		72	16	9	21	43
50	38	55		71	15	7-8	20	42
49	37	53-54		70	14	6	19	41
47-48	36	52		69	12-13	5	18	40
46	35	51		68	11	4	16-17	39
45	34	50		67	10	3	15	38
44	33	49		66	9	2	14	37
43	31-32	47-48		65	8	1	13	36
41-42	30	46		64	6-7	0	12	35
40	29	45		63	5		10-11	34
39	28	44		62	4		9	33
38	27	43		61	3		8	32
37	26	41-42		60	1-2		7	31
35-36	25	40		59	0		6	30
34	24	39		58			4-5	29
33	23	38		57			3	28
32	22	37		56			2	27
30-31	21	35-36		55			1	26
							0	25

*Percentage scoring below the scaled score is based on the performance of 9,569 examinees who took the Biochemistry, Cell and Molecular Biology Test between October 1, 1997, and September 30, 2000.

Evaluating Your Performance

Now that you have scored your test, you may wish to compare your performance with the performance of others who took this test. Both the worksheet on page 56 and the tables on page 57 use performance data from GRE Biochemistry, Cell and Molecular Biology Test examinees.

The data in the worksheet on page 56 are based on the performance of a sample of the examinees who took this test in December 2000. This sample was selected to represent the total population of GRE Biochemistry, Cell and Molecular Biology Test examinees tested between October 1997 and September 2000. The numbers in the column labeled “P+” on the worksheet indicate the percentages of examinees in this sample who answered each question correctly. You may use these numbers as a guide for evaluating your performance on each test question.

The first table on page 57 contains, for each scaled score, the percentage of examinees tested between October 1997 and September 2000 who received lower scores. Interpretive data based on the scores earned by examinees tested in this three-year period will be used by admissions officers in the 2001-02 testing year. These percentages appear in the score conversion table in a column to the right of the scaled scores. For example, in the percentage column opposite the scaled score of 530 is the number 50. This means that 50 percent of the GRE Biochemistry, Cell and Molecular Biology Test examinees tested between October 1997 and September 2000 scored lower than 530. To compare yourself with this population, look at the percentage next to the scaled score you earned on the practice test.

Your three subscores show your relative strengths or weaknesses in the three subfield areas of the GRE Biochemistry, Cell and Molecular Biology Test. The raw subscores are scaled in such a way that they are related to the total scores on the test. On the average, a person who has a comprehensive background in the field can expect to have subscores equal to about one-tenth of his or her total score. Thus, if you have a total score of 600, and your undergraduate program placed equal emphasis on the three areas of biochemistry, cell and molecular biology represented by the subscores, you would expect to have a scaled subscore of about 60 in each area. If, however, your subscores differ by more than a few points, you may take this as an indication that your lower score shows weakness, and you may wish to concentrate your review efforts on topics in that area.

It is important to realize that the conditions under which you tested yourself were not exactly the same as those you will encounter at a test center. It is impossible to predict how different test-taking conditions will affect test performance, and this is only one factor that may account for differences between your practice test scores and your actual test scores. By comparing your performance on this practice test with the performance of other GRE Biochemistry, Cell and Molecular Biology Test examinees, however, you will be able to determine your strengths and weaknesses and can then plan a program of study to prepare yourself for taking the GRE Biochemistry, Cell and Molecular Biology Test under standard conditions.

DO NOT USE INK

Use only a pencil with soft, black lead (No. 2 or HB) to complete this answer sheet. Be sure to fill in completely the space that corresponds to your answer choice. Completely erase any errors or stray marks.

1. NAME Enter your last name, first name initial (given name), and middle initial if you have one. Omit spaces, apostrophes, Jr., II, etc.

Last Name only (Family or Surname) - first 15 letters

First Name Initial Middle Name Initial

Grid for name entry with columns for Last Name, First Name Initial, Middle Name Initial, and a large grid for letters A-Z.

2. YOUR NAME: Last Name (Family or Surname) First Name (Given) M.I. (Print)

MAILING ADDRESS: P.O. Box or Street Address (Print)

City State or Province

Country Zip or Postal Code

CENTER: City State or Province

Country Center Number Room Number

SIGNATURE:

GRADUATE RECORD EXAMINATIONS - GRE - SUBJECT TEST

SIDE 1

BE SURE EACH MARK IS DARK AND COMPLETELY FILLS THE INTENDED SPACE AS ILLUSTRATED HERE: YOU MAY FIND MORE RESPONSE SPACES THAN YOU NEED. IF SO, PLEASE LEAVE THEM BLANK.

Main grid for multiple-choice questions, numbered 1 through 114, with columns for answer choices A, B, C, D, E.

3. DATE OF BIRTH

Form for date of birth with columns for Month, Day, and Year, and rows for months from Jan to Dec.

4. SOCIAL SECURITY NUMBER (U.S.A. only)

Form for social security number with a grid of circles for digits 0-9.

5. REGISTRATION NUMBER (from your admission ticket)

Form for registration number with a grid of circles for digits 0-9.

6. TITLE CODE (on back cover of your test book)

Form for title code with a grid of circles for digits 0-9.

7. TEST NAME (on back cover of your test book)

FORM CODE (on back cover of your test book)

8. TEST BOOK SERIAL NUMBER (find number in upper right corner of front cover of your test book)

SHADED AREA FOR ETS USE ONLY

SUBJECT TEST

COMPLETE THE
CERTIFICATION STATEMENT,
THEN TURN ANSWER SHEET
OVER TO SIDE 1.

CERTIFICATION STATEMENT

Please write the following statement below, DO NOT PRINT.
"I certify that I am the person whose name appears on this answer sheet. I also agree not to disclose the contents of the test I am taking today to anyone."
Sign and date where indicated.

SIGNATURE: _____ DATE: _____
Month Day Year

BE SURE EACH MARK IS DARK AND COMPLETELY FILLS THE INTENDED SPACE AS ILLUSTRATED HERE: ●
YOU MAY FIND MORE RESPONSE SPACES THAN YOU NEED. IF SO, PLEASE LEAVE THEM BLANK.

115	A	B	C	D	E	147	A	B	C	D	E	179	A	B	C	D	E	211	A	B	C	D	E
116	A	B	C	D	E	148	A	B	C	D	E	180	A	B	C	D	E	212	A	B	C	D	E
117	A	B	C	D	E	149	A	B	C	D	E	181	A	B	C	D	E	213	A	B	C	D	E
118	A	B	C	D	E	150	A	B	C	D	E	182	A	B	C	D	E	214	A	B	C	D	E
119	A	B	C	D	E	151	A	B	C	D	E	183	A	B	C	D	E	215	A	B	C	D	E
120	A	B	C	D	E	152	A	B	C	D	E	184	A	B	C	D	E	216	A	B	C	D	E
121	A	B	C	D	E	153	A	B	C	D	E	185	A	B	C	D	E	217	A	B	C	D	E
122	A	B	C	D	E	154	A	B	C	D	E	186	A	B	C	D	E	218	A	B	C	D	E
123	A	B	C	D	E	155	A	B	C	D	E	187	A	B	C	D	E	219	A	B	C	D	E
124	A	B	C	D	E	156	A	B	C	D	E	188	A	B	C	D	E	220	A	B	C	D	E
125	A	B	C	D	E	157	A	B	C	D	E	189	A	B	C	D	E	221	A	B	C	D	E
126	A	B	C	D	E	158	A	B	C	D	E	190	A	B	C	D	E	222	A	B	C	D	E
127	A	B	C	D	E	159	A	B	C	D	E	191	A	B	C	D	E	223	A	B	C	D	E
128	A	B	C	D	E	160	A	B	C	D	E	192	A	B	C	D	E	224	A	B	C	D	E
129	A	B	C	D	E	161	A	B	C	D	E	193	A	B	C	D	E	225	A	B	C	D	E
130	A	B	C	D	E	162	A	B	C	D	E	194	A	B	C	D	E	226	A	B	C	D	E
131	A	B	C	D	E	163	A	B	C	D	E	195	A	B	C	D	E	227	A	B	C	D	E
132	A	B	C	D	E	164	A	B	C	D	E	196	A	B	C	D	E	228	A	B	C	D	E
133	A	B	C	D	E	165	A	B	C	D	E	197	A	B	C	D	E	229	A	B	C	D	E
134	A	B	C	D	E	166	A	B	C	D	E	198	A	B	C	D	E	230	A	B	C	D	E
135	A	B	C	D	E	167	A	B	C	D	E	199	A	B	C	D	E	231	A	B	C	D	E
136	A	B	C	D	E	168	A	B	C	D	E	200	A	B	C	D	E	232	A	B	C	D	E
137	A	B	C	D	E	169	A	B	C	D	E	201	A	B	C	D	E	233	A	B	C	D	E
138	A	B	C	D	E	170	A	B	C	D	E	202	A	B	C	D	E	234	A	B	C	D	E
139	A	B	C	D	E	171	A	B	C	D	E	203	A	B	C	D	E	235	A	B	C	D	E
140	A	B	C	D	E	172	A	B	C	D	E	204	A	B	C	D	E	236	A	B	C	D	E
141	A	B	C	D	E	173	A	B	C	D	E	205	A	B	C	D	E	237	A	B	C	D	E
142	A	B	C	D	E	174	A	B	C	D	E	206	A	B	C	D	E	238	A	B	C	D	E
143	A	B	C	D	E	175	A	B	C	D	E	207	A	B	C	D	E	239	A	B	C	D	E
144	A	B	C	D	E	176	A	B	C	D	E	208	A	B	C	D	E	240	A	B	C	D	E
145	A	B	C	D	E	177	A	B	C	D	E	209	A	B	C	D	E	241	A	B	C	D	E
146	A	B	C	D	E	178	A	B	C	D	E	210	A	B	C	D	E	242	A	B	C	D	E

IF YOU DO NOT WANT THIS ANSWER SHEET TO BE SCORED

If you want to cancel your scores from this administration, complete A and B below. You will not receive scores for this test; however, you will receive confirmation of this cancellation. No record of this test or the cancellation will be sent to the recipients you indicated, and there will be no scores for this test on your GRE file. Once a score is canceled, it cannot be reinstated.

To cancel your scores from this test administration, you must:

A. fill in both ovals here . . . ○ — ○ B. sign your full name here: _____

TR	TW	TFS	TCS	1R	1W	1FS	1CS	2R	2W	2FS	2CS
FOR ETS USE ONLY				3R	3W	3FS	3CS	4R	4W	4FS	4CS
				5R	5W	5FS	5CS	6R	6W	6FS	6CS



54082-007628 • U81M8.5 • Printed in the U.S.A.

I.N. 991070