

Compact Disc Recorder
CDR-W33
 Operating Instructions



Thank you very much for purchasing this Sony product. Sony products are designed with safety in mind. If electrical products are used incorrectly, however, there is a risk of death or serious injury, so be sure to obey the following to avoid accidents.

TABLE OF CONTENTS

Safety	2
Getting Started	5
Location and Function of Parts	6
Discs	9
Recording	10
Operations on the Disc's TOC Area	18
Playback	23
Control Terminal Functions and Settings	27
Setup Menu Operations	28
Miscellaneous	29

WARNING

Notice for the Customers in the United Kingdom

IMPORTANT

The wires in this mains lead are coloured in accordance with the following code:

Blue: Neutral
Brown: Live

As the colours of the wires in the mains lead of this apparatus may not correspond with the coloured markings identifying the terminals in your plug, proceed as follows:

The wire which is coloured blue must be connected to the terminal which is marked with the letter N or coloured black.

The wire which is coloured brown must be connected to the terminal which is marked with the letter L or coloured red. Do not connect either wire to the earth terminal in the plug which is marked by the letter E or by the safety earth symbol \perp or coloured green or green-and-yellow.

For customers in the U.S.A

To prevent fire or shock hazard, do not expose the unit to rain or moisture.

To avoid electrical shock, do not open the cabinet. Refer servicing to qualified personnel only.

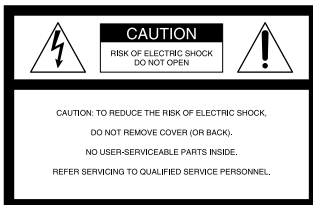

This symbol is intended to alert the user to the presence of uninsulated "dangerous voltage" within the product's enclosure that may be of sufficient magnitude to constitute a risk of electric shock to persons.



This symbol is intended to alert the user to the presence of important operating and maintenance (servicing) instructions in the literature accompanying the appliance.

CAUTION

Use of this product other than directed may result in injury.

DANGER

INVISIBLE LASER RADIATION WHEN OPEN.
AVOID DIRECT EXPOSURE TO BEAM.

DANGER

RADIATIONS INVISIBLES DU LASER EN CAS D'OUVERTURE.
EVITER TOUTE EXPOSITION DIRECTE AU FAISCEAU.

This label is located on the rear of the unit.

CAUTION

You are cautioned that any changes or modification not expressly approved in this manual could void your authority to operate this equipment.

INFORMATION

This equipment has been tested and found to comply with the limits for a Class B digital device, pursuant to Part 15 of the FCC Rules. These limits are designed to provide reasonable protection against harmful interference in a residential installation. This equipment generates, uses, and can radiate radio frequency energy and, if not installed and used in accordance with the instructions, may cause harmful interference to radio communications.

However, there is no guarantee that interference will not occur in a particular installation. If this equipment does cause harmful interference to radio or television reception, which can be determined by turning the equipment off and on, the user is encouraged to try to correct the interference by one or more of the following measures:

- Reorient or relocate the receiving antenna.
- Increase the separation between the equipment and receiver.
- Connect the equipment into an outlet on a circuit different from that to which the receiver is connected.
- Consult the dealer or an experienced radio/TV technician for help.

For customers in Europe

The laser component in this product is capable of emitting radiation exceeding the limit for Class 1.

This appliance is classified as a CLASS 1 LASER product.

The CLASS 1 LASER PRODUCT MARKING is located on the rear exterior.

CLASS 1 LASER PRODUCT
LUOKAN 1 LASERLAITE
KLASS 1 LASERAPPARAT

The following caution label is located inside the unit.



For customers in Canada

This Class B digital apparatus complies With Canadian ICES-003.

CAUTION

TO PREVENT ELECTRIC SHOCK, DO NOT USE THIS POLARIZED AC PLUG WITH AN EXTENSION CORD, RECEPTACLE OR OTHER OUTLET UNLESS THE BLADES CAN BE FULLY INSERTED TO PREVENT BLADE EXPOSURE.

ATTENTION

POUR PREVENIR LES CHOCS ELECTRIQUES, NE PAS UTILISER CETTE FICHE POLARISEE AVEC UNPROLONGATEUR, UNE PRISE DE COURANT OU UNE AUTRE SORTITE DE COURANT SAUF SI LES LAMES PEUVENT ETRE INSEREES A FOND SANS EN LAISSER AUCUNE PARTIE A DECOUVERT.

Setting the voltage selector (voltage selector equipped models only)

Check that the voltage selector on the rear panel is set to the local power line voltage. If not, set the selector to the correct position using a screwdriver before connecting the AC power cord to a wall outlet.

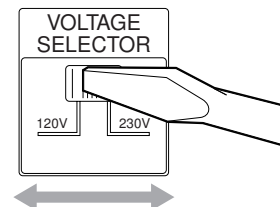

Owner's Record

The model and serial numbers are located on the rear of the unit. Record the serial number in the space provided below. Refer to them whenever you call upon your Sony dealer regarding this product.

Model No. _____

Serial No. _____

IN NO EVENT SHALL SELLER BE
LIABLE FOR ANY DIRECT,
INCIDENTAL OR
CONSEQUENTIAL DAMAGES OF
ANY NATURE, OR LOSSES OR
EXPENSES RESULTING FROM
ANY DEFECTIVE PRODUCT OR
THE USE OF ANY PRODUCT.

Precautions

On safety

- Should any solid object or liquid fall into the cabinet, unplug the recorder and have it checked by qualified personnel before operating it any further.
- Caution – The use of optical instruments with this product will increase eye hazard.

On power sources

- Before operating the recorder, check that the operating voltage of the recorder is identical with your local power supply. The operating voltage is indicated on the nameplate at the rear of the recorder.
- The unit is not disconnected from the AC power source (mains) as long as it is connected to the wall outlet, even if the unit itself has been turned off.
- If you are not going to use the recorder for a long time, be sure to disconnect the recorder from the wall outlet. To disconnect the AC power cord, grasp the plug itself; never pull the cord.
- AC power cord must be changed only at the qualified service shop.

On condensation

If the recorder is brought directly from a cold to a warm location, or is placed in a very damp room, moisture may condense on the lenses inside the recorder. Should this occur, the recorder may not operate properly. In this case, remove the MD and leave the recorder turned on for several hours until the moisture evaporates.

On cleaning

Clean the cabinet, panel and controls with a soft cloth slightly moistened with mild detergent solution. Do not use any type of abrasive pad, scouring powder or solvent such as alcohol or benzine.

If you have any questions or problems concerning your recorder, please consult your nearest Sony dealer.

Main Features

Compatible with both CD-R and CD-RW media

By performing a CD-R finalize operation, you can play the CD on an ordinary CD player. Use CD-RW to delete the recording. You can also use this product to play ordinary CDs.

Sampling rate converter

You can record not only CD and MD 44.1 kHz digital signals, but also 32 kHz and 48 kHz digital sources such as DAT, satellite digital broadcasts, DVD, etc., using a digital connection.

24-bit A/D, D/A converter

The product is equipped with a 24-bit A/D, D/A converter.

Equipped with a Super Bit Mapping (SBM) filter

When converting 24-bit data to 16-bit data, you can record at better than ordinary 16-bit sound quality by weaving the least-significant 8-bit information into the 16-bit data recorded, rather than simply truncating the data. (Enabled only with analog sound input.)

Equipped with digital equalizer and digital limiter

You can convert sound to high acoustic pressure and prevent hard clips using the digital limiter. You can change sound character using digital equalizer. (Both are enabled only with analog input.)

Record disc name and track name in CD-TEXT format

You can record up to 23 characters each for disc name and track name.

Equipped with skip setting function

You can create discs that play back by skipping unwanted tracks from among those that have been recorded. This setting is enabled all compatible CD-R recorders.

Equipped with useful recording functions such as fader function, mute recording, music sync recording, and auto track marking.

Also equipped with numerous playback functions in addition to normal playback, such as shuffle mode, program mode, auto-pause, music scan, and repeat play.

Equipped with both analog input/output and digital input/output (optical and coaxial).

Supplied with special remote control that can be used both wireless and wired.

You can use IBM-compatible keyboard with a PS/2 interface, instead of using the supplied remote control.

TABLE OF CONTENTS

Getting Started

Removing Packaging	5
Connections	5

Location and Function of Parts

Front Panel Descriptions	6
Back Panel Descriptions	7
Remote Descriptions	8

Discs

Discs Recordable Using the CD Recorder	9
Handling Discs	9
Finalizing	9

Recording

Recording on a Disc	10
Recording Precautions	11
Switching Display During Recording	11
Adjusting the Recording Level	12
Adjusting Right and Left Level Balance	12
Monitoring Sound Inputs (Input Monitor)	12
Marking Track Numbers while Recording (Track Marking)	12
Synchro-recording with the Input Source (Music Synchro-recording)	13
Adding Mute Sections (Mute)	13
Fade-in /Fade-out Recording	14
DSP (Digital Signal Processing) Settings	14
Synchro-recording with a Sony CD Player (CD Synchro-recording)	17
Digital Recording Without Sampling Rate Converter	17

Operations on the Disc's TOC Area

Finalizing (FINALIZE)	18
Adding Track Name and Disc Name (NAME)	18
Setting Skip/Unskip Tracks	20
Unfinalizing	21
Erasing Tracks (TRACK ERASE)	22
Erasing All Tracks (DISC ERASE)	22

Playback

Playing a Disc	23
Switching Display During Playback	23
Playing a Specific Track	24
Pausing After Each Track (Auto-Pause)	24
Playing Tracks Repeatedly	24
Creating Your Own Program (Program Play)	25
Playing Tracks in Random Order (Shuffle Play)	26
Music Scan	26

Control Terminal Functions and Settings

Control-S Input Terminal (CTRL-S)	27
Keyboard Jack	27

Setup Menu Operations

Basic Setup Menu Operations	28
Setup Menu Table	28

Miscellaneous

Precautions	29
Dimensions	30
Specifications	31
Troubleshooting	32
Display Messages	33

Removing Packaging

This CD Recorder comes with the following items:

- Remote Control (remote) RM-CW1 (1)
- R6 (size-AA) batteries (2)
- Control-S connector cable (1)

If any of the above items are not enclosed, contact your Sony dealer, or the Sony Service Center.

Inserting Batteries into the Remote

Insert two R6 (size-AA) batteries (supplied) with the + and - properly oriented to the markings into the battery compartment.

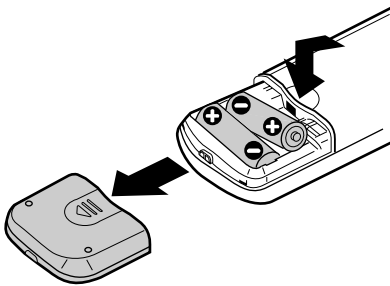

💡 Under normal conditions, the batteries should last for about six months.

When the remote no longer operates the recorder, replace both batteries with new ones.

Caution

- If the batteries are inserted correctly, there is a danger of leakage or damage. Be sure to observe the following:
 - Insert the batteries with the ⊕ and ⊖ terminals correctly oriented.
 - Do not use a new battery with an old one.
 - Do not recharge the batteries.
 - If not using the remote control for an extended period of time, remove the batteries to avoid possible damage from battery leakage and corrosion.
 - If the batteries are leaking, wipe clean the battery holder, and then replace with new batteries.
- When using the remote control, do not expose the remote sensor to direct sunlight or a lighting apparatus. Doing so may cause a malfunction.

Connections

Connection Precautions

Before making connections, turn OFF the power supply to all devices. Insert all plugs firmly, as an improper connection may cause hum and noise. Use a cable with sufficient length to ensure that the plug does not come use due to shock or vibration.

Device connection example

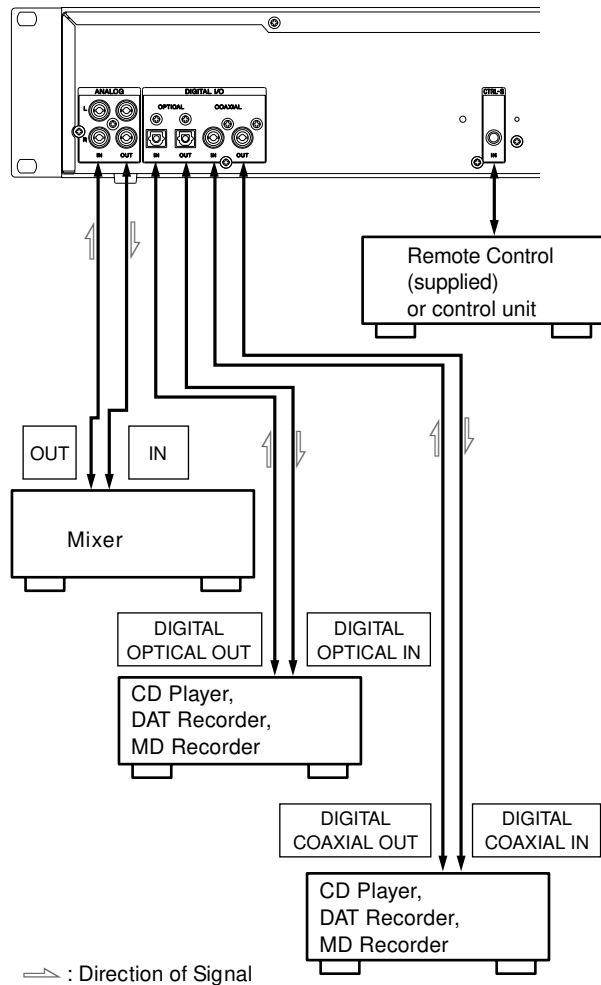

Keyboard connection and settings

Refer to Keyboard Jack, page 27.

💡 The product is equipped with a sampling rate converter. All digital input signals are converted to the sampling frequency (44.1 kHz) for recording. Consequently, you can make digital recordings using not only CDs and MDs, but also DAT (32 kHz and 48 kHz) and digital broadcasting (32 kHz and 48 kHz), which have different sampling frequencies.

Front Panel Descriptions

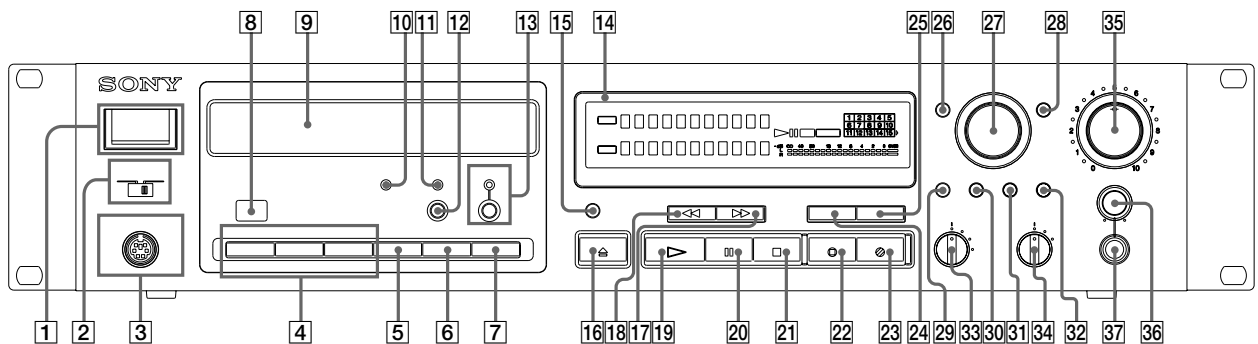

- 1 Power switch**
Press to turn ON or OFF the CD recorder.
- 2 Timer selector**
Use to set the timer to playing (PLAY). When set to PLAY, the CD recorder will start playing automatically when the power supply is turned ON.
- 3 Keyboard jack**
Connect a PS/2 interface keyboard (sold separately) to this jack.
- 4 PLAY MODE**
Use to select the desired play mode.
• CONTINUE button
Press this button for normal play.
• SHUFFLE button
Play the tracks in random order.
• PROGRAM button
Play tracks in selected order.
- 5 REPEAT button**
Press to play tracks repeatedly.
- 6 A-B button**
Press to select Repeat A-B play.
- 7 A-PAUSE button**
Pause automatically at the start of the next track to be played.
- 8 Remote sensor**
Operate by pointing the supplied remote control at this sensor.
- 9 Disc insertion tray**
Insert the disc here.
- 10 CD-R indicator**
Lit when a CD-R is detected.
- 11 CD-RW indicator**
Lit when a CD-RW is detected.
- 12 ERASE button**
Press to erase tracks, whole discs, or to unfinalize.
- 13 FINALIZE button and FINALIZE indicator**
Press to finalize. When a finalized disc is inserted, the indicator is lit.
- 14 Display window**
Shows the status of the CD recorder.
- 15 DISPLAY button**
Press to switch between disc information and track time information.
- 16 ▲ (OPEN/CLOSE) button**
Press to open and close the disc tray.
- 17 ►► (Fast forward) button**
Press to fast forward to the section you want to play.
- 18 ◀◀ (Fast backward) button**
Press to rewind to the section you want to play.
- 19 ► (Play) button**
Press to start play. In recording standby mode, press to start recording.
- 20 || (Pause) button**
Press to pause play or recording, and press again to restart play or recording.
- 21 ■ (Stop) button**
Press to stop play or recording.
- 22 ○ (REC MUTE) button**
Press to create a mute section during recording.
- 23 ● (REC) button**
Press to record on the CD, monitor the input signal, or mark track numbers.
- 24 FADER button**
Press during recording to fade in and fade out.

- 25 MUSIC SYNC button**
Press to start Music Synchro-recording.
- 26 MENU/NO button**
Use to select the Setup menu.
- 27 AMS control**
Turn to locate tracks and select the input characters.
- 28 YES button**
Confirm the Setup menu selection.
- 29 NAME button**
Press to switch to name input mode.
- 30 CHAR button**
Select the type of character to be input uppercase letters, lowercase letters and number.
- 31 CLEAR button**
Clear the characters and program that has been entered.
- 32 CHECK button**
Displays the program details.
- 33 SBM / LIMITER/ EQ control**
Press to turn ON and OFF DSP (Digital Signal Processing) effects.
- 34 INPUT switch**
Select sound source to be input to the CD recorder.
- 35 REC LEVEL control**
Use to adjust the analog input sound level.
- 36 PHONE LEVEL control**
Use to adjust the volume of the headphones.
- 37 PHONES jack**
Connect headphones to this jack.

Back Panel Descriptions

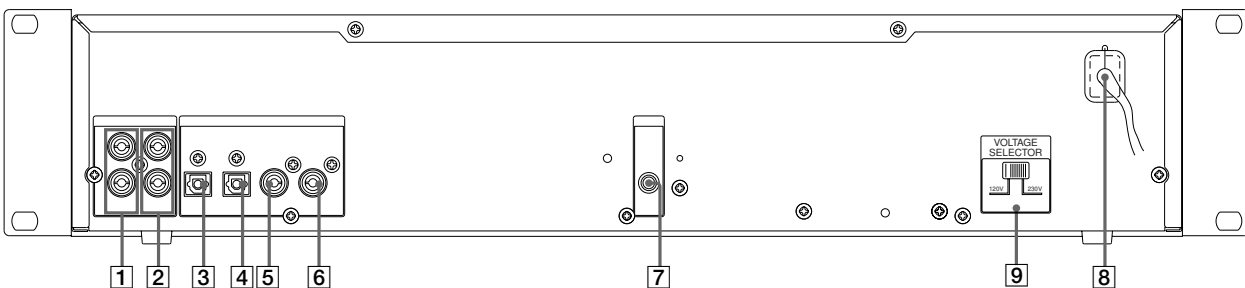

- 1 Analog input terminal**
Connect to the analog output terminal of a mixer or playback device.
- 2 Analog output terminal**
Connect to the analog input terminal of a mixer, amplifier or recorder.
- 3 Digital (optical) input terminal**
Connect to the optical digital output terminal of a digital device. Compatible with consumer digital audio interface format.
- 4 Digital (optical) output terminal**
Connect to the optical digital input terminal of a digital device.
- 5 Digital (coaxial) input terminal**
Connect to the coaxial digital output terminal of a digital device. Compatible with consumer digital audio interface format.
- 6 Digital (coaxial) output terminal**
Connect to the coaxial digital input terminal of a digital device.
- 7 Control-S input terminal**
Connect to the supplied remote controller or another control device.
- 8 Power supply cable**
Connect to the power outlet.
- 9 Voltage selector (Except for the US models)**
Select 120V or 230V according to the local power line voltage. (Refer to page 2)

Remote Descriptions

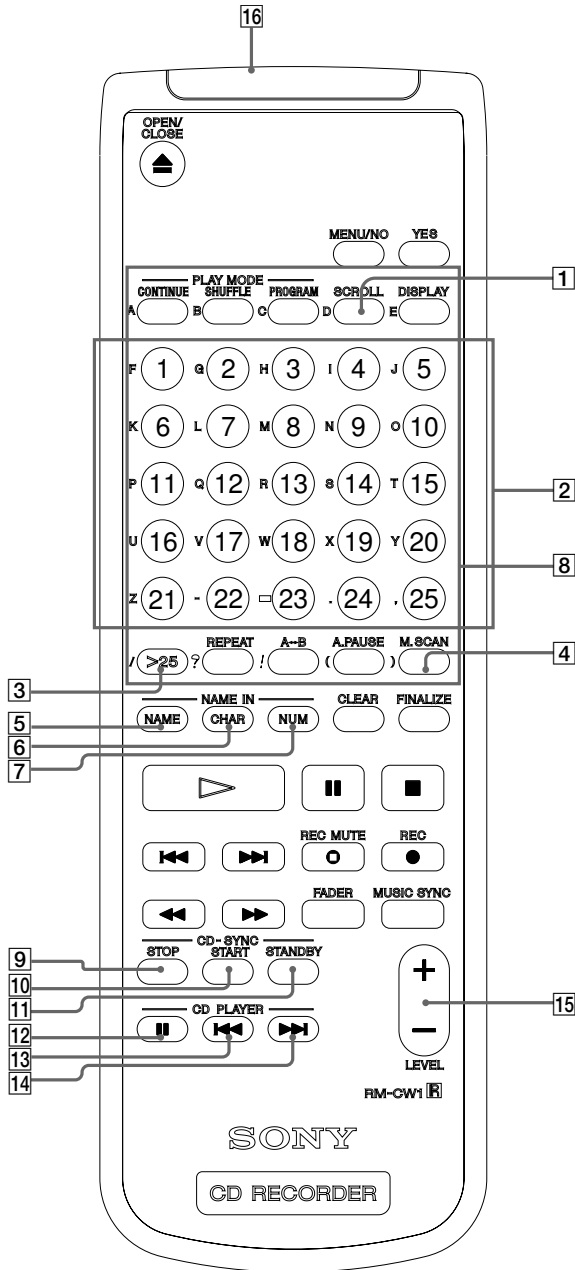

The buttons on the remote with the same display as the front panel have the same function. This section explains the functions of buttons that are on the remote only.

- 1 SCROLL button**
Use to scroll the name of a track or disc.
- 2 Number buttons**
Press to select a track number directly.
- 3 >25 button**
Use to select a track number greater than 25.
- 4 M.SCAN (music scan) button**
Press to start music scan.

NAME IN (NAME/CHAR/NUM/Character button)

- 5 NAME button**
Press to add the name or change the name of a track or disc.
- 6 CHAR button**
When entering characters using the remote, press to select the type of characters to be input. You can also switch between uppercase and lowercase letters.
- 7 NUM button**
When entering characters using the remote, press to enter numbers using buttons 1 to 10. Here, button 10 enters the number 0.
- 8 Character button**
When entering names, you can enter characters using the orange display buttons. Buttons 1 to 10 can be used after switching between number and alphabet inputs using the NUM and CHAR buttons.

CD-SYNC (STOP/START/STANDBY)

By connecting a Sony CD player, you can make recording easily. The remote operates both the CD player and the CD recorder, so install the CD player and CD recorder close together.

- 9 STOP button**
Press to stop CD Synchro-recording.
- 10 START button**
Press to start CD Synchro-recording.
- 11 STANDBY button**
Press to enter standby for CD Synchro-recording.

CD PLAYER (II/I<</>>I)

Use to output a Sony CD player remote signal. You can perform the following operations using these buttons instead of a CD player remote control.

- 12 II button**
Press to pause play.
- 13 I<< button**
Press to return to the start of the track currently playing, or to the start of the previous track.
- 14 >>I button**
Press to move to the start of the next track.
- 15 LEVEL +/- button**
Use to adjust the digital input sound level without entering the Setup menu.
- 16 Control-S output terminal**
By connecting the remote control to the control-S terminal using the supplied cable, you can use the remote control as a wired remote. Connecting the plug to this terminal disables the infrared beam.

Discs Recordable Using the CD recorder

Use discs with the following markings or inscriptions .

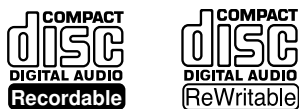

FOR CONSUMER
FOR CONSUMER USE
FOR MUSIC USE ONLY

Handling Discs

You can record on CD-R disc only once. Tracks recorded on CD-R disc cannot be erased. Recordings on CD-RW disc can be erased and used again.

When a CD-R or CD-RW disc is inserted into the CD recorder, the indicator to show the type of disc will light on the front panel. If a play-only CD is inserted, the indicator will not light.

(Example: CD-R disc)

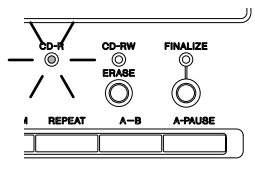

Do not use malformed discs. Doing so may cause damage to the CD recorder.

Finalizing

Finalizing is the process of writing a TOC (Table of Contents, track time and other information) to a CD-R or CD-RW disc. Before a disc is finalized, you can add additional recordings, but after a disc is finalized, further recording is disabled. Consequently, perform finalizing after completing recordings to the disc.

CD-R Discs

Until a CD-R disc is finalized, it cannot be played on a CD player. By finalizing, a CD-R disc can be played on a CD player as well as on this CD recorder. Unfinalized CD-R discs can be played on the CD recorder regardless.

CD-RW Discs

By finalizing a CD-RW disc can be played on a CD-RW-compatible CD player, but depending on the physical specifications, a CD-RW disc cannot be played on a CD player that is not CD-RW-compatible. Unfinalized CD-RW discs can be played on the CD recorder regardless.

💡 When finalizing, you can add disc and track names using this CD recorder.

💡 If a finalized disc is inserted, the finalized indicator will light, and a frame will appear around the music calendar.

1	2	3	4	5	← Music Calendar
6	7	8	9		

Recording on a Disc

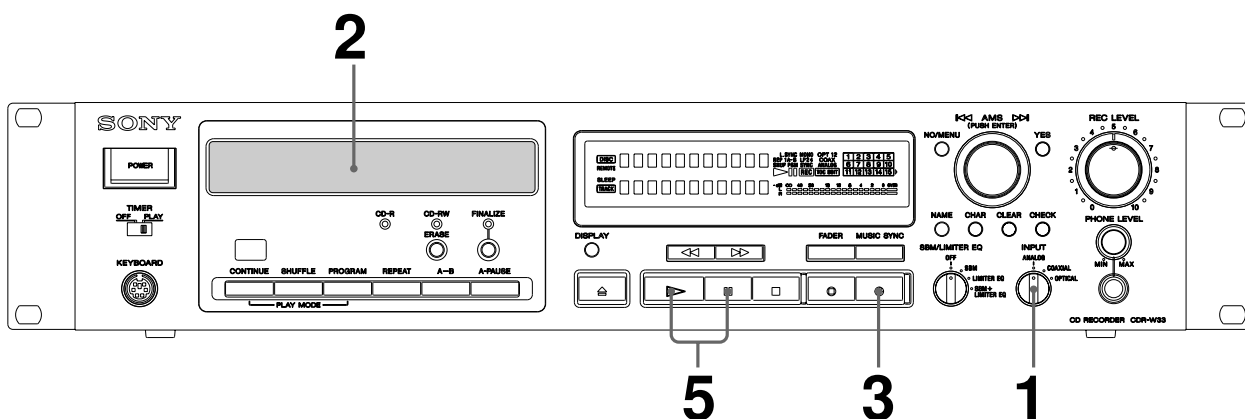

1 Select the input signal using the INPUT switch on the front panel.

ANALOG: Selects an analog signal input from the analog terminal.

COAXIAL: Selects a digital signal input from the digital coaxial terminal.

OPTICAL: Selects a digital signal input from the digital optical terminal.

2 Insert a CD-R disc or CD-RW disc.

3 ● Press the REC button.

Pressing the REC button enters recording standby mode. (▶|| REC will be displayed.)

The number of the next track to be recorded will be displayed. The track number will flash while the recorder is setting up, and when setup is complete, the track number will remain lit and the track time will be displayed. The input signal is monitored from the output terminal.

4 Adjusting the recording level

During recording and when in recording standby mode, the input signal level is displayed in the level meter, so you can adjust the recording level. Refer to page 12, "Adjusting the Recording Level."

5 Press the ▷ or || button.

Recording will start, and the recording time will be displayed. (▶ REC will be displayed.)

6 Start play on the input device.

To stop recording,
press the ■ button.

To pause recording,
press the || button.
The CD recorder will enter recording standby mode.

To restart recording,
Press the ▷ button or the || button.
A new track number will start from the location at which recording is restarted.

💡 Silent pause function

If the digital input remains mute for 30 seconds, the CD recorder will automatically pause recording. If making a digital recording from a CD or MD, mute recording will not continue after the source play has stopped.

Recording Precautions

When recording on a previously recorded disc

Make sure to add the new recording after the existing one. You cannot record while overwriting existing recordings.

Track numbers

You cannot edit track numbers after recordings.

When starting a recording from stop mode, the track number is added automatically following on from the track number of the last completed recording. When starting a recording from pause mode, the track numbers are automatically contiguous.

For how to add track numbers during recording, refer to page 12 "Marking Track Numbers while Recording (Track Marking)."

Sampling Rate Converter

A sampling rate converter is built into the CD recorder, so you can convert all digital input signals to the CD sampling frequency (44.1 kHz) for recording. Consequently, you can also record DAT and satellite broadcast digital signals, which have a different sampling frequency.

Writing to PMA (Program Memory Area)

When recording to a CD-R/RW disc, immediately after the **■** button is pressed, the recorded track number and track time information is automatically recorded in the program memory area on the disc. If writing to the PMA is not performed correctly, the recorded data is disabled, and the disc itself can no longer be used.

To make sure of writing to the PMA after completing recording, do not turn OFF the power supply to the CD recorder under the following conditions.

- During recording.
- When in pause mode after a recording.
- After pressing the **■** button, while *PMA Writing* is displayed. (Writing to the PMA takes approximately 5 seconds after recording has finished.)

Maximum Number of Tracks that can Be Recorded on a Disc

Depending on the CD specifications, you can record a maximum of 99 tracks on the CD-R/RW disc. Even if there is still space to record more on the disc, you cannot exceed 99 tracks. When the 99th track is being recorded, you cannot pause recording by pressing the **||** button. Stop the recording by pressing the **■** button.

Minimum Track Recording Time

You cannot record tracks less than 4 seconds long.

Switching Display During Recording

Pressing the DISPLAY button during recording changes the display as follows.

Track recording time

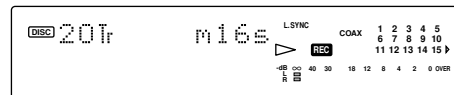

Recording time remaining on disc

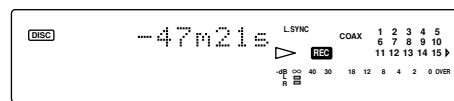

Input signal recording level (coaxial and optical inputs only)

In this display, you can adjust the recording level by turning the AMS control.

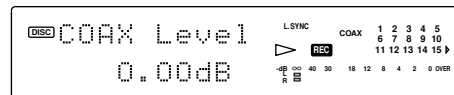

💡 You can hold the maximum level display on the level meter until performing manual reset.

Using peak hold display while inputting signals in recording mode and record standby mode before actually making a recording, you can check the maximum input signal value. Use this value to calibrate the recording level adjustment.

To use peak hold display, turn ON the Peak Hold setting in the Setup menu. Refer to page 28, "Setup Menu Operations."

To reset the peak hold display, use one of the following two methods.

- Turn OFF and then ON again Peak Hold in the setup menu.
- During recording mode or recording standby mode, press the CLEAR button.

You can also use peak hold display when playing discs.

Adjusting the Recording Level

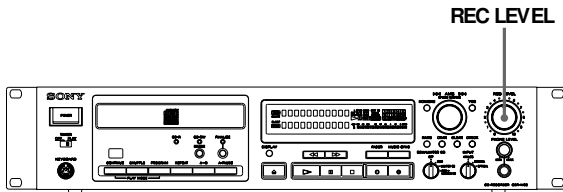

• Analog Inputs

You can adjust the recording level using the REC LEVEL control on the front panel. Adjust the recording level so that OVER on the level meter is not normally lit.

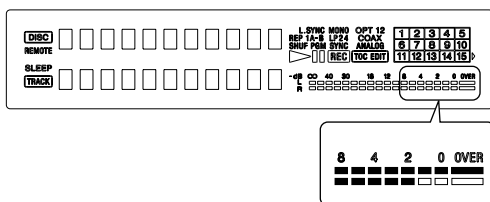

• Digital Inputs

You can adjust the recording level using "COAX Level" or "OPT Level" in the Setup menu.

Operations Using the Remote

You can adjust the level of the input signal selected using the LEVEL +/- button.

• Monitor Outputs During Recording

During recording, the sounds recorded are output to all the output terminals. With outputs to digital output terminals during recording of digital (coaxial or optical) inputs, however, input signals are output without adjustment as monitor outputs.

Consequently, in this case sounds in which recording level adjustments are not reflected are output, but the sound recorded on the disc is the adjusted one.

Adjusting Right and Left Level Balance

With analog inputs, you can adjust the left and right volume balance using "ANA L/R Bal" in the Setup menu. (With digital inputs, you cannot adjust the left and right volume balance. Refer to page 28, "Setup Menu Operations.")

Monitoring Sound Inputs (Input Monitor)

If the ● button is pressed when no disc has been inserted, you can make the selected input signal a monitor output. During input monitoring, if an analog input is selected, "AD-DA" will be displayed. If a digital input is selected, "-DA" will be displayed.

Marking Track Numbers while Recording (Track Marking)

There are two methods of adding track numbers: Manual track marking, in which you can add track numbers to suit your own timing, and auto track marking, which adds track numbers automatically. Select which method you want to use using "TrMark/Lsync" in the Setup menu.

TrMark/Lsync

ON: Auto track marking is enabled. The L.SYNC mark in the display window will light. In this setting, you cannot mark track numbers manually.

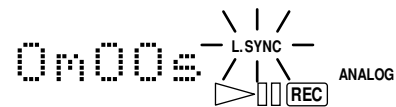

OFF: Auto track marking is disabled. Manual track marking is enabled, and you can add track numbers manually.

For Setup menu details, refer to page 28, "Setup Menu Operations".

Make the "TrMark/Lsync" settings in stop mode before starting a recording. You cannot change the "TrMark/Lsync" setting during recording or in recording standby mode.

Marking Track Numbers Manually (Manual Track Marking)

Manual track marking is only possible when "TrMark/Lsync" is turned OFF (i.e., L.SYNC mark is not lit). Press the ● button during recording to add the track number in the desired place.

Automatically Marking Track Number (Auto Track Marking/Level Sync)

This function is enabled when "TrMark/Lsync" is turned ON (i.e., L.SYNC mark is lit). The operation is different for analog inputs and digital (coaxial or optical) inputs.

Analog Inputs (Level Sync)

Track numbers are added when the signal sinks below the threshold for approximately 3 seconds, and then rises above the threshold level again. Set the threshold level using L.Sync Level in the Setup menu. For Setup menu details, refer to page 28, "Setup Menu Operations".

Digital Inputs

When recording a CD, MD, or DAT, track numbers are added according to changes in the track number sound source. If recording a digital sound source other than CD, MD, or DAT, track numbers are added depending on level sync in the same way as analog signals.

The timing for adding track numbers with CD, MD, and DAT sound sources is as follows:

- CD: When the sound is detected after the input signal track changes.
- MD: When the input signal track changes.
- DAT: When a start ID is detected.

Synchro-recording with the Input Source (Music Synchro-recording)

This function starts recording automatically from recording standby mode, depending on the input signal.

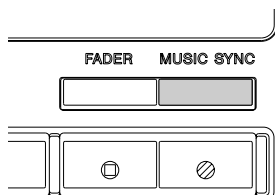

- 1** Select the input while in stop mode.
- 2** Press the **MUSIC SYNC** button.
The CD recorder will enter recording standby mode in input signal waiting mode, and "MUSIC SYNC" will flash. When the CD recorder is ready, "SYNC" and "Ready" will light.
- 3** Start playing the sound source you want to record.
Recording will start automatically.

Adding Mute Sections (Mute)

You cannot edit tracks after recording as with an MD, so the CD recorder is equipped with a mute function with which to mute sections after a track as necessary.

Press the **○** button during recording...

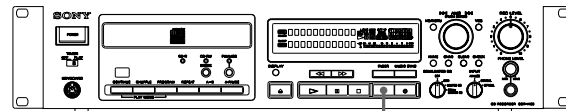

"REC Mute" will flash, and a mute section approximately 4 seconds long will be added. The CD recorder will then return to record standby mode.

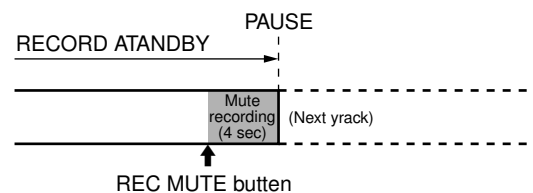

Press the **○** button after pausing from record standby mode to add an approximately 4-second mute section after the track that has just been recorded, before returning to record wait mode once again.

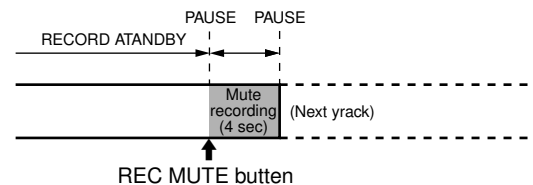

 To create a mute section longer than 4 seconds, press and hold the **○** button for the desired length of time you require the mute section to last.

You cannot create a mute section at the start of a track using the **○** button. Only one mute section can be added to each track.

Fade-in/Fade-out Recording

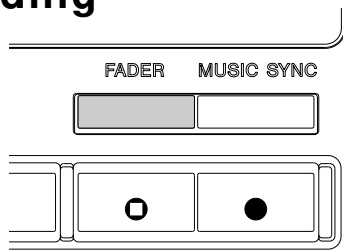

Fading In Recordings

- 1 **Make sure that the CD recorder is in recording standby mode.**
- 2 **Press the FADER button.**
Recording will begin once the last sound has gone, and the volume will rise automatically to the normal recording volume.

Fading Out Recordings

- 1 **Make sure that the CD recorder is in recording mode.**
- 2 **Press the FADER button.**
The volume will automatically decrease and the CD recorder will enter record standby mode.

Adjusting Fade-in/Fadeout Time

You can set the fade-in/fadeout time between 1 and 8 seconds, using "Fader Time" in the Setup menu screen.

DSP (Digital Signal Processing) Settings

You can make recordings of analog input signals while applying the following processes: Digital equalizer, digital limiter, and Super Bit Mapping. The block diagram of the analog input signal part to the CD recorder is shown below.

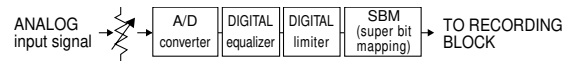

Using SBM (Super Bit Mapping)

To make recordings using the SBM filter, set the SBM/LIMITER/EQ control to "SBM" or "SBM + LIMITER + EQ".

SBM/LIMITER/EQ

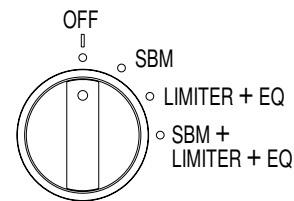

SBM Filter

The CD recorder is equipped with a 24-bit A/D converter, but the CD format itself is set at 16 bits as the universal standard. Consequently, you must convert the data, which was A/D-converted using 24 bits, to 16 bits to record. In this case, the simplest method is to omit the least-significant 8 bits of the 24-bit data. (This happens when SBM is turned OFF.) This, however, wastes much of the 24-bit data output from the A/D conversion. Using SBM processing, the least-significant 8 bits of the 24-bit data is woven into the 16-bit data while pushing outside of audible range the quantum noise when converting to 16 bits, by creating in the noise shaping filter frequency characteristics that take account of human auditory characteristics. In this way, although called 16-bit data, you can record the detailed sound quality on the original 24-bit data without degradation. In addition, SBM function operates during recording, so discs recorded using SBM processing reproduce the same sound quality when played on other CD players.

 **Depending on the headphones and your system, SBM effects may not be wholly effective.**

Using the Digital Limiter and Digital Equalizer

To make recordings using the limiter and equalizer effects, set the "SBM/LIMITER/EQ" control to "LIMITER + EQ" or "SBM + LIMITER + EQ". Make detailed settings for each item using the Setup menu. For details, refer to page 28, "Setup Menu Operations".

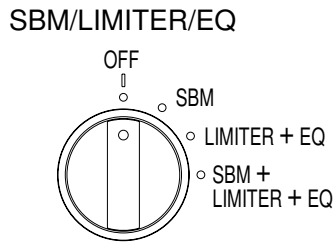

Digital Equalizer Setting

The CD recorder is equipped with a 3-band digital equalizer, a shelving equalizer for bass and trable frequency bands, and a parametric equalizer for middle frequency band. Adjust the parameters to make detailed settings using the Setup menu. For details, refer to page 28, "Setup Menu Operations".

Parameters and Variable Ranges

Bass frequency:	50 Hz to 1 kHz
Bass level:	-6.0 dB to 6.0 dB
Mid frequency:	100 Hz to 10 kHz
Mid level:	-6.0 dB to 6.0 dB
Mid width:	Narrow/Mid/Wide
Treble frequency:	1 kHz to 12.5 kHz
Treble level:	-6.0 dB to 6.0 dB

 Setting the band level parameter to high on the + side may cause the signal level to rise to the clip level internally, resulting in the sound warping. If this occurs, lower the input level using the REC LEVEL control knob.

Equalizer Frequency Characteristics

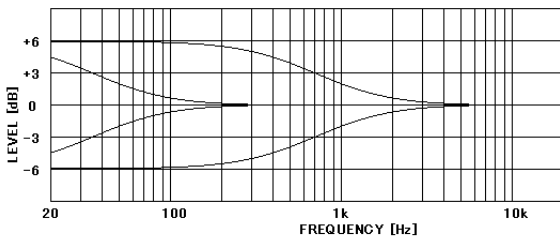

Bass equalizer

Frequency = 50 Hz, 1 kHz when each level = ± 6 dB.

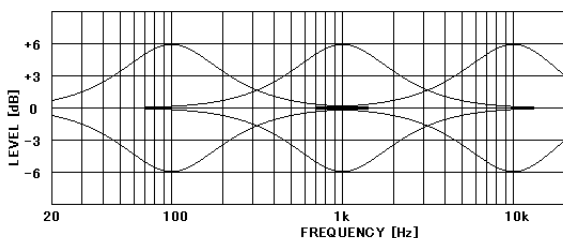

Mid equalizer

Frequency = 100 Hz, 1 kHz, 10 kHz when each level = ± 6 dB.

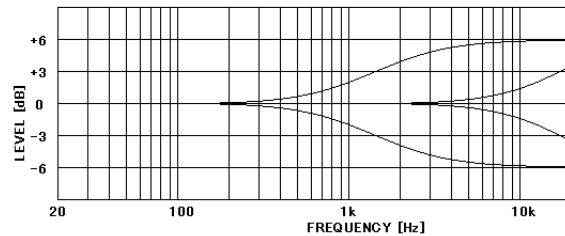

Treble equalizer

Frequency = 1 kHz, 12.5 kHz when each level = ± 6 dB.

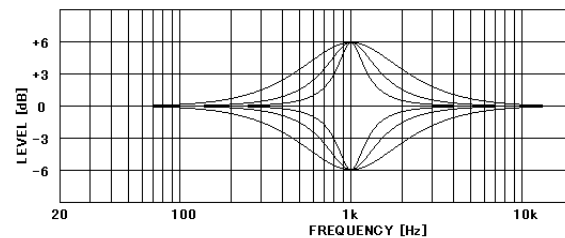

Mid equalizer

Frequency = 1 kHz and level = ± 6 dB when width is changed to 3 levels.

Digital Limiter

The digital limiter, which is used when performing CD mastering, can also be used without adjustment for simulation processing. Low level parts of signal are raised without distortion, and high level parts of signal are processed using soft clip signal waveforms to prevent hard clipping, so you can convert the entire recorded acoustic pressure level without audibly increasing distortion.

LIM Ratio Parameter (Limiter Ratio)

Variable range: 0% to 100% (0.00 dB to 6.02 dB).

The percentage is the effective ratio. There is no effect at 0%. At 100%, the maximum effect is yielded. Decibels express the amount of gain for the ratio (in the area of -20 dB maximum).

Waveform Variance During Limiter Operation

When input signal is below -20dB.

Signal level is doubled (when ratio = 100%)

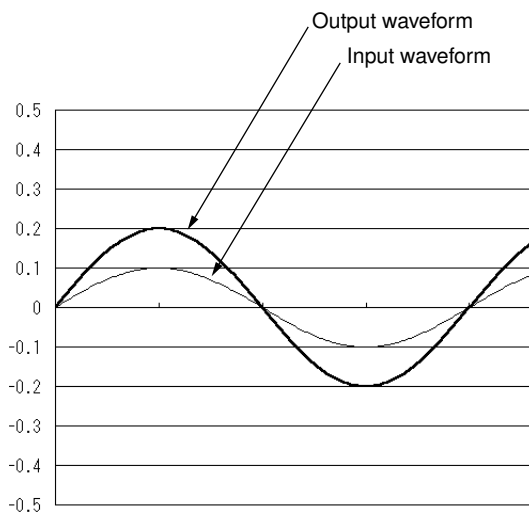

When input signal is over -20dB.

Peak part of the signal is soft-clipped.
(When ratio = 100%)

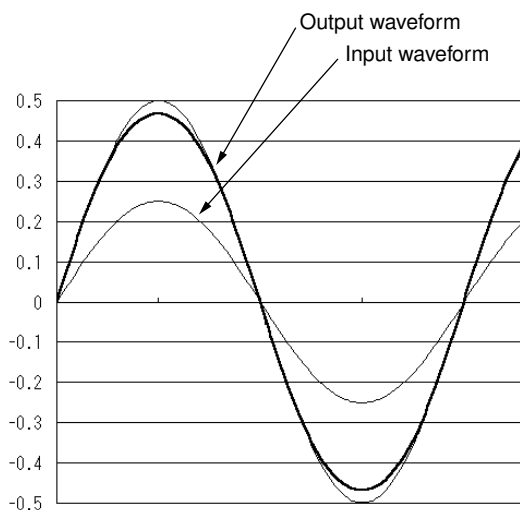

Using Digital Limiter Effectively

1 Convert the signal to high level.

When setting the analog input recording level, basically set the REC LEVEL control so that hard clipping does not occur in the greatest part of the level during A/D conversion. Even so, this may result conversely in the entire level being too low. If this is the case, when using the digital limiter, raise the low recording level using soft clipping to prevent audible distortion of high recording level.

2 Change the sound characteristic using soft clipping.

Limiter soft clipping is an effect resembling saturation on a tape recorder. Soft clipping is performed on input signals exceeding -20 dB, so setting a high level using the REC LEVEL control and adjusting the effect ratio using the LIM Ratio parameter achieves a forceful sound with little ear-grating distortion.

Level Variance During Limiter Operation

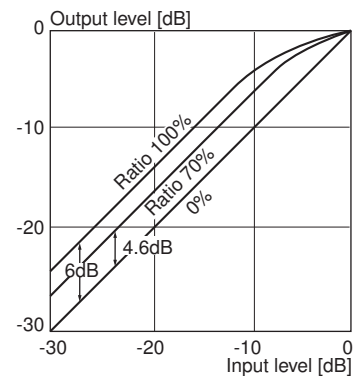

Synchro-recording with a Sony CD Player (CD Synchro-recording)

By connecting a Sony CD player to the CD recorder, you can easily record from CDs just by pressing the CD SYNC key on the remote. The remote operates both the CD player and the CD recorder, so install the CD player and CD recorder close together. (Use as a wireless remote.) Enabling the CDP remote operation function may cause incorrect operation, so make sure the setting is disabled. For details, refer to page 28, "Setup Menu Operations".

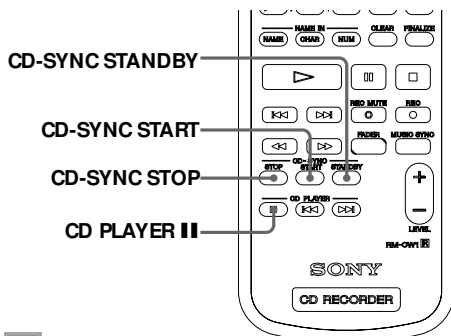

- 1** In the Setup menu, set CDP remote operation function to "Disable".
- 2** Insert the source disc in the CD player.
- 3** Insert a recordable disc into the CD recorder, and select the input to suit the CD player connection.
Turn ON the auto track marking from the Setup menu as necessary to enable automatic track numbering.
- 4** On the remote, press the CD-SYNC STANDBY button.
The CD player changes to play standby, and the CD recorder changes to recording standby mode.
- 5** Press the CD-SYNC START button on the remote.
The CD recorder starts recording, and the CD player starts to playing.

- 6** Press the CD-SYNC STOP button on the remote to stop recording at the desired position.
Note that with analog inputs, the CD recorder will continue to record even if CD playback has stopped.

To pause synchro recording, press the CD-SYNC STANDBY button on the remote.

To restart recording, press the CD-SYNC START button. The track number will change at the point where the recording was paused.

You can also use the CD player remote during CD synchro recording.

Press the STOP button to stop the CD player, and pause the CD recorder.

Press the PAUSE button to pause the CD player, and pause the CD recorder.

Press the PLAY button to restart CD synchro recording.

Digital Recording Without Sampling Rate Converter

If recording digital signals at 44.1 kHz sampling frequency from a CD or MD source, you can record without using the sampling rate converter (SRC).

In the Setup menu, set the setup item to "44.1kDirect". For details, refer to page 26, "Setup Menu Operations".

OFF: Use SRC to record.

ON: Do not use SRC to record.

Precautions

If recording sampling frequency signals of 32 kHz and 48 kHz using a DAT or BS tuner source, the setting is disabled, and sampling rate converter is automatically used during the recording. If sampling frequency of input signal changes or switches to other frequency, do not use this function (i.e., turn OFF the 44.1kHzDirect function) to stabilize the recording.

Finalizing (FINALIZE)

CD-R/CD-RW

CD-R discs can be played on ordinary CD players when they have been finalized, but you cannot change the disc status, such as adding additional tracks.

CD-RW discs can be played on CD-RW-compatible CD players when they have been finalized. You can later add or delete tracks on CD-RW discs by unfinalizing (i.e., undoing the finalizing) them.

Once finalizing has started, it cannot be stopped.

Finalizing takes approximately 130 seconds from start to finish. During this time, do not turn OFF the power supply to the CD recorder, as this will damage the TOC of disc, you will not be able to use the disc again.

Operating Procedure

- 1** Press the FINALIZE button.
- 2** The CD recorder will enter check mode. "Start?" and "ENTER/YES" will be displayed alternately.
- 3** If you are ready to finalize, press the AMS control or the YES button.
If you are not ready, press the MENU/NO button. When finalizing starts, "Finalize" will flash in the display. The countdown time remaining until finalizing finishes will be displayed.
- 4** When finalizing is completed, the FINALIZE indicator will light.

Finalized discs cannot be finalized again. You cannot finalize discs on which nothing has been recorded.

Adding Track Name and Disc Name (NAME)

CD-R/CD-RW

You can add disc names and track names in to discs in CD-text format. The disc names and track names that have been entered are written to the disc when the disc is finalized. Consequently, enter the names just before finalizing the disc.

Note: Removing discs or turning OFF the power supply before the disc is finalized but a name has been entered will result in the name data being lost.

You can record up to 23 characters each for disc name and track name.

You can use the following characters.

Alphabet: A to Z, and a to z.

Numbers: 0 to 9

Symbols: ! " # \$ % & ' () * + , - . / : ; < = > ? @ [\] ^ _ ` { | } ~ (blank)

After entering the name, if you try to remove the disc without finalizing, the following warning message will be displayed: "Text Edited sure ▲?" If you do not want to save the name, press the ▲ button again within 4 seconds.

Adding Names Using the CD recorder

- 1** In stop mode, press the NAME button.
- 2** **Select whether you want to enter the disc name or track number.**
Make the selection by turning the AMS control, and then press the AMS control or the YES button.
- 3** **Enter the name.**
The cursor will flash to show the position of the character being input. Turn the AMS control to select the character, and then press the AMS control to verify the character and move the cursor one place to the right.
Use the ◀◀ button and ▶▶ button to move the cursor position left and right.
Press the CLEAR button to delete the character on which the cursor is positioned, and to move all of the following characters one place back.
Press the CHAR button to select the character type. Pressing the CHAR button cycles through "A", "a", and "0" once each time the button is pressed. Having selected the character type, turn the AMS control to select the desired character.
- 4** **Once the character has been entered, press the YES button.**
The CD recorder will return to disc or track number selection status.
- 5** **Repeat steps 2 to 4 to enter the desired track and disc name.**
- 6** **Finally, press the MENU/NO button to quit the name input setup menu screen.**

Adding Names Using the Remote

- 1** Press the NAME button.
- 2** **Select whether you want to enter the disc name or track number.**
Press the ◀◀ button and ▶▶ button to make the selection, and then press the YES button.
- 3** **Enter the name.**
You can make the selection using the ◀◀ button, ▶▶ button, ◀◀ button, and ▶▶ button in the same way as the main CD recorder, but you can also enter the alphabet directly using the remote using the following procedure.
Select the desired character type.
Press the CHAR button to switch between uppercase and lowercase letters. When in uppercase, "Selected AB" will be displayed, and when in lowercase, "Selected ab" will be displayed. Press the NUM button to enter numbers directly. "Selected 12" will be displayed.
Entering Characters
In alphabet input mode, you can enter the characters A to Z and other symbols directly using the remote. If number input is selected, you can enter the numbers 0 to 9 directly, instead of the letters F to O. (Use the 10 key to enter 0.)
When a character is entered, the cursor moves one place to the right.
Press the CLEAR button to delete the character on which the cursor is positioned, and to move all of the following characters one place back.
- 4** **Once the character has been entered, press the YES button.**
The CD recorder will return to disc or track number selection status.
- 5** **Repeat steps 2 to 4 to enter the desired track and disc name.**
- 6** **Finally, press the MENU/NO button to quit the name input setup menu screen.**

Adding Names Using a Personal Computer Keyboard (Sold Separately)

For the basic keyboard settings, refer to page 27, "Keyboard Terminal".

- 1** Press the Num Lock (NAME) key to enter the name input setup menu screen.
- 2** Select whether you want to enter the disc name or track number.
Press the [Tab] key and [Shift + Tab] key to make the selection, and then press the Enter key to confirm.
- 3** Enter the name.
Enter the name using the keyboard as with a personal computer.
Entering Lowercase Characters
Use the alphabet keys. (Use the [Shift] key + the alphabet keys if Caps Lock is enabled).
Entering Uppercase Characters
Use the [Shift] key + the alphabet keys (Use the alphabet keys, if Caps Lock is enabled).
Entering Numbers
Use the number keys to enter the numbers.
Canceling adding a name
To cancel the name adding, press the [ESC] key.
Switching Between Uppercase and Lowercase Characters
Use the [Caps Lock] key to switch between uppercase and lowercase characters.
Moving the Cursor
Use the [←] and [→] keys to move the cursor left and right.
Deleting Characters
Position the cursor over the character you want to delete, and then press the [Delete] key.
Deleting the Character Before the Cursor
To delete the character before the cursor, press the [Back Space] key.
- 4** Once the character has been entered, press the [Enter] key.
The CD recorder will return to disc or track number selection status.
- 5** Repeat steps 2 to 4 to enter the desired track and disc name.

- 6** Finally, press the MENU/NO button to quit the name input setup menu screen.

Setting Skip/Unskip Tracks CD-R/CD-RW

When playing a CD-R/RW disc that you have recorded, you can skip tracks to which you do not want to listen.

The skip function is determined by the CD-R/RW specifications, and can be written on the disc. Discs that have been set to skip can be played with skipping by enabling the skip setting on a CD recorder (CD player) that is skip function compatible. (You cannot use skip play on CD recorders and CD players that are not skip function compatible.)

Setting skip and unskip for tracks is only possible on discs before they are finalized. After finalizing, the disc setting cannot be changed.

Setting Skip/Unskip

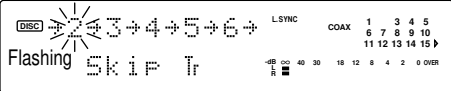
- 1** In the Setup menu, select Skip/Unskip Track Edit, and then press the AMS control or the YES button.
This menu item is not displayed for discs that have been finalized.
- 2** The recorded track numbers will be displayed. The current setting status for the flashing track number will be displayed as shown below.

Tracks to be skipped: "Skip Tr"
Tracks not to be skipped: "Unskip Tr"
When the desired track number is flashing, press the AMS control to change the skip/unskip status for that track.
- 3** To change the setting for another track, turn the AMS control to select the track number.
- 4** When you have finished the settings for all the tracks, press the YES button to confirm.

5 "PMA Write?" will be displayed. Select whether to record in the PMA area.

If you write to the PMA area, the setting information will remain even if the disc is removed from the CD recorder, and so remains valid even if another disc is inserted. If not writing to the PMA area, press the MENU/NO button. The setting information will not be written to the disc. In this case, the setting information will be stored until the disc is removed or the power is turned OFF.

💡 You can play discs without the skip that has been set. Turn OFF "Skip Play" in the menu. The skip setting will be ignored, and all recorded tracks will be played.

💡 Limits to the number of times you can write skip information to the PMA area of a disc.

CD-R DISC:

The area to which skip information can be written on a disc is limited. Consequently, write skip/unskip information to the PMA area immediately before removing the disc, and avoid writing the information an unnecessary number of times. The number of times the information can be written depends on the number of tracks set at the time. The skip memory area in which skip information is set, and the unskip memory area in which previous skip settings are undone store 21 blocks each. Each block can store a maximum of 6 tracks. For example, recording a 7th skip track in one block will result in a second block being used. The same is true for the unskip operation. When all 21 blocks for both skip and unskip have been used, you cannot make additional settings.

Writing skip settings to the PMA.

Writing skip settings to the PMA.

1	2Tr	3Tr	5Tr	8Tr			← 4 tracks written to PMA 1st time.
2	4Tr	6Tr	7Tr	10Tr	11Tr	13Tr	
3	15Tr						← 7 tracks written to PMA 2nd time.
4							
5							
20							
21							

CD-RW DISC:

There are no limits to the number of times you can write to the PMA, but the maximum number of skip settings is 21 tracks.

Unfinalizing CD-RW

You can restore CD-RW disc to the status they were immediately before the disc was finalized. This operation is called unfinalizing. You cannot add further recordings or delete tracks from a finalized CD-RW disc, but can do so by unfinalizing the disc.

You cannot cancel an unfinalize operation once it has started.

Unfinalizing takes approximately 80 seconds from start to finish. During this time, do not turn OFF the power supply to the CD recorder. The disc's TOC information will be corrupted, and you will no longer be able to use the disc.

Operating Procedure

This operation is valid only with finalized CD-RW discs.

- 1 Press the ERASE button.**
"Start?" and "ENTER/YES" will be displayed alternately for verification. Press the MENU/NO button to quit.
- 2 Press the AMS button or the YES button.**
"Unfinalize" will flash. The countdown time remaining until unfinalizing finishes will be displayed. When the display stops flashing, unfinalizing is complete.

💡 Unfinalizing discs with disc name and track name information.

The information is stored until the disc is removed or the power supply is turned OFF, in the same state as after it was entered. Consequently, you can edit the information or add other tracks names.

Erasing Tracks (TRACK ERASE) CD-RW

You can erase tracks recorded on CD-RW discs. If erasing, you can erase (a specified number of tracks from) the last track recorded. (For example, you cannot erase only the 5th track on a disc on which 10 tracks have been recorded in total.) To delete tracks from a CD-RW that has been finalized, first unfinalize on the disc to enable the erase function.

You cannot stop a track erase operation it has started.

Do not turn OFF the power supply to the CD recorder while tracks are being erased. The disc's TOC information will be corrupted, and you will no longer be able to use the disc.

Operating Procedure

- 1 Press the ERASE button.**
- 2 If deleting multiple tracks, set the range of tracks to be deleted by turning the AMS control.**
Press the MENU/NO button to quit.
- 3 Press the AMS control or the YES button.**
Erasing will start, and "Track Erase" will flash. When the display stops flashing, erasing is complete.

 **The names of the erased tracks will also be erased at the same time. If you have selected to erase all tracks, the disc name will also be erased.**

Erasing All Tracks (DISC ERSE) CD-RW

You can delete all the tracks currently written to a CD-RW disc, and reuse the disc. This operation is possible regardless of whether or not the disc has been finalized.

You cannot stop a disc erase operation once it has started.

Erasing the disc takes approximately 90 seconds. Do not turn OFF the power supply to the CD recorder while tracks are being erased. The disc's TOC information will be corrupted, and you will no longer be able to use the disc.

- 1 Press the ERASE button.**
If the disc has not been finalized, the erase tracks verification screen will be displayed. If the disc has been finalized, the unfinalize verification screen will be displayed.
- 2 Press the ERASE button once again. "Disc Erase Start?" will be displayed.**
Press the MENU/NO button to quit.
- 3 Press the AMS control or the YES button.**
"Disc Erase" will flash. The countdown time remaining until erasing finishes will be displayed. When the display stops flashing, erasure is complete.

Playing a Disc

1 Insert a disc.

When a disc is inserted, the CD recorder will enter stop mode, and the following will be displayed in the display window: Total number of tracks on the disc, total recording time, and the disc name (if a name has been added).

2 Press the ▷ button.

The disc starts to play.

To stop play, press the ■ button.

To pause play, press the || button.

To restart play, press the ▷ button or the || button.

To fast forward, press and hold the ►► button while the disc is playing.

The disc will start to play normally from the point at which you remove your finger.

To fast backward, press and hold the ◀◀ button while the disc is playing. The disc will start to play normally from the point at which you remove your finger.

To remove the disc, press the ▲ button. If you press the ▲ button while the disc is playing also, the playback will stop and the tray will open, so you can remove the disc.

You may become disable disc removal during play.

In the Setup menu, select ▲ mode. Refer to page 28, "Setup Menu Operations", for details.

Switching Display During Playback

Pressing the DISPLAY button during recording changes the display window as follows:

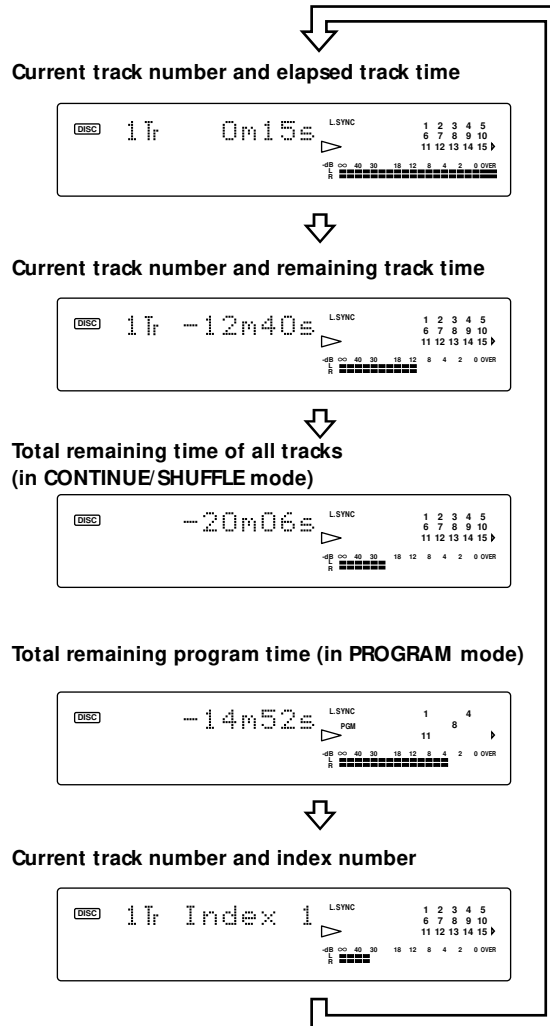

If the track title is stored on the disc in CD-text-compatible format, the title will be displayed in the lower line of the window.

Playing a Specific Track

Selecting previous or next tracks while playing or paused (AMS track selection).

To select the start of a preceding or later track while playing or paused, turn the AMS control. (AMS = Automatic Music Sensor)

Turn the control to the right (▶▶) to select a higher track number, and to the left (◀◀) to select a lower track number. Performing an AMS control operation during play will start the selected track from its beginning, and performing an AMS control operation during pause will move to the start of the selected track, and then pause play.

Selecting Tracks Directly by Track Number (Direct Selection)

You can select a track number directly using the number buttons on the remote, or on a keyboard. Making a selection during play will start the selected track from its beginning, and making a selection during pause will move to the start of the selected track, and then pause play.

💡 Directly Selecting Tracks with a Higher Track Number than 25

Press the >25 button, and then enter the number in the order of 10s and units using the number buttons (1 to 10). (Button 10 enters the number 0.)

Example: Selecting track No. 30

Press the buttons in the following order: >25 button, 3 button, 10 button.

Selecting Track Number Using the CD Recorder

Stop play, and then turn the AMS control until the desired track is displayed. Next, press the ▷ button to start playing the selected track.

Pansing After Each Track (Auto-Pause)

This function automatically pauses at the start of the next track after the previous track has finished playing. Turn ON and OFF the function by pressing the A-PAUSE button.

When Auto-Pause is ON, play automatically pauses at the start of a track, and Auto Pause is displayed.

When Auto-Pause is OFF, play does not pause at the start of a track, and continues to play the next track normally.

Playing Tracks Repeatedly (Repeat Play)

Cycle between the following by pressing the REPEAT button: Normal play → Repeat all tracks → Repeat 1 track → Normal play. Use the A-B button to operate A-B repeat.

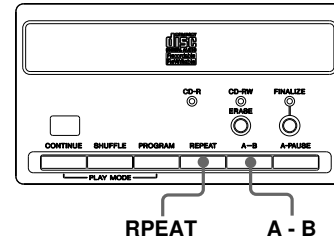

Repeat All Tracks

Press the REPEAT button. "REP" will be displayed. When the last track has finished playing, the CD recorder will automatically return to the beginning and start to play.

- In CONTINUE play mode, the disc will play in track order from first to last, and then repeat again from the start.
- In SHUFFLE play mode, when the last track has finished playing, shuffle play will start again from the beginning.
- In PROGRAM play mode, when all the programs have finished playing, play will start again from the first step of the program.

Repeat 1 Track

Press the REPEAT button. "REP 1" will be displayed, and the current track will be played repeatedly. If auto-pause is turned ON, the CD recorder will automatically pause at the start of the track each time.

A-B Repeat

Specify a part of the current track you want to listen to. That part will play repeatedly. A-B Repeat can only be used in CONTINUE play mode.

- 1 During play, press the A-B button to specify the start point of the part you want to repeat (point A). "REP A-" will light, and "B" will flash.
- 2 Continue play as normal (or press the ▶▶ button) until the track reaches the end point of the part you want to repeat (point B). Press the A-B button again to specify point B. "REP A-B" will light, and A-B repeat will start.

To cancel A-B repeat and resume normal play, press the REPEAT button.

To change the repeat area, press the A-B button while playing A-B repeat.

The current point will become the new point A. Set a new point B to start a new A-B repeat.

💡 You cannot specify an A-B repeat play that straddles two tracks.

💡 You cannot use A-B repeat play on unfinalized discs.

Creating Your Own Program (Program Play)

You can program the play order of the tracks to which you want to listen on the disc.

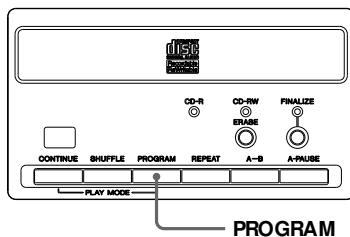

Setting Program Details

1 In stop mode, press the PROGRAM button to enter program play mode.

"PGM" is displayed in the display window.

2 Turn the AMS control to select the track number. (The selected track will be added after the last track in the program.)

Upper line display: Number of steps and total program time.

Lower line display: Track numbers in program order.

3 Press the AMS control to confirm.

The display returns to next program track selection.

4 Repeat steps 2 and 3 to set the desired program.

5

Press the YES button, or wait 20 seconds for the display to automatically quit setting mode.

Press the CLEAR button in program mode to delete the last track from the program.

Press the CHECK button in program mode to check the track order in the program.

Use the number buttons on the remote to select tracks in program mode. And The selected track numbers will be added to the end of the program.

To start program play,

press the ▷ button. Play starts in the order of tracks in the program.

To select tracks to be played during program play,

turn the AMS control to select tracks in the order of tracks in the program.

💡 You can program a maximum of 25 steps in one program, or a total program time of 999 minutes.

💡 Program details remain stored until the disc is removed, or the power supply is turned OFF.

Playing Tracks in Random Order (Shuffle Play)

You can play all tracks on the disc in random order.

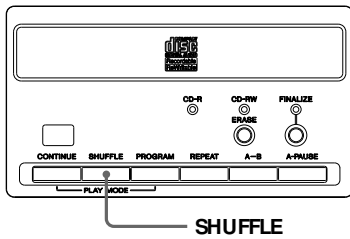

- 1 **Press the SHUFFLE button.**
The CD recorder will enter shuffle play mode, and "SHUF" will be displayed in the display window.

- 2 **Press the ▷ button.**

To select tracks during shuffle play, turn the AMS control to the right to select the next track to be played. If you turn the AMS control to the left, play will restart from the start of the track currently playing. You cannot select tracks that have already been played.

Music Scan

You can play the start of tracks one after the other for a fixed time only to check the order of tracks.

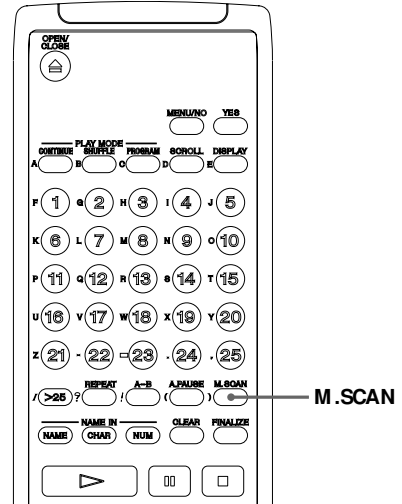

Press the M.SCAN button on the remote.

Press the ▷ button during music scan to end music scan and restart normal play from the current track.

- In CONTINUE play mode: Play all tracks in track order.
- In SHUFFLE play mode: Play all tracks in random order.
- In PROGRAM play mode: Play all programmed tracks in program order.

💡 Adjusting Play Time for the Start of Tracks During Music Scan

You can set the music scan time from 6 to 14 seconds using "M.ScanTime" in the Setup menu screen. For details, refer to page 28, "Setup Menu Operations".

Control-S Input Terminal (CTRL-S)

The Control-S input terminal on the CD recorder can perform control operations from external devices by connecting external devices other than the supplied remote control to system controller, which is equipped with a CTRL-S terminal.

Controllable Functions

You can control all the same functions as with the remote control. When the remote is plugged into the control-S terminal, the infrared sensor is disabled.

Keyboard Terminal

Installing a Keyboard

You can use any keyboard * that is IBM ** PC/AT or compatible with a PS/2 interface. You can use either a Japanese or English keyboard. (Recommended keyboard: SONY KB-10.) Use a keyboard with a current consumption of 120 mA max.

** IBM is a registered trademark of International Business Machines Corporation.

* Power consumption must be 120mA or less.

Connecting a Keyboard

Connect the keyboard connector to the keyboard terminal on the front panel of the CD recorder. The keyboard will be enabled approximately 4 seconds after connection.

Selecting Keyboard Type

Select whether the keyboard is Japanese or English using the menu operations.

- 1 Press the MENU/NO button and turn the AMS control. Display "PC Keyboard", and then press the AMS control or the YES button.
- 2 Turn the AMS control to select one of the following.
JP Type: Use a Japanese keyboard.
US type: Use an English keyboard.
- 3 Press the AMS control or YES button.

The functions of all the buttons on the CD recorder and the remote are allocated to the keyboard, so you can perform various operations using the keyboard instead of the CD recorder and the remote. The key allocations are shown in the following diagram.

Entering Track Names and Disc Name Using the Keyboard

You can enter track names and disc name using the keyboard. The keyboard is useful for directly entering alphabet and numbers. For the operating procedure, refer to page 18, "Adding Track Name and Disc Name (NAME)".

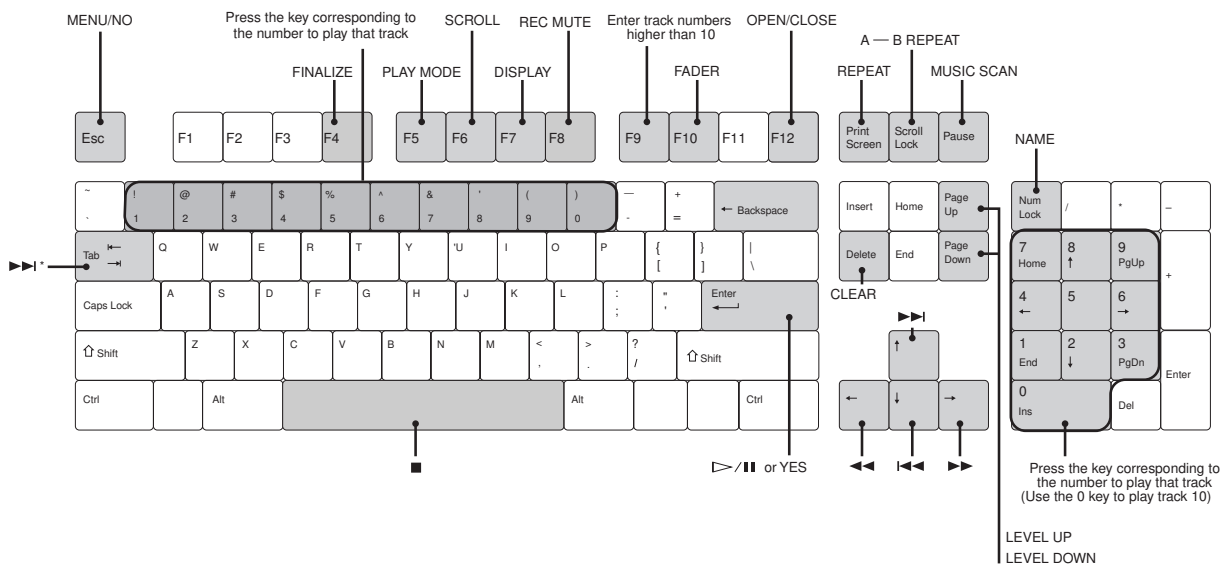

*⌘: Shift + Tab

REC ●: Shift + Enter

MUSIC SYNC: Ctrl + Enter

Adding Names

Use the Caps Lock key to switch between uppercase and lowercase characters.

Setup Menu Operations

Basic Setup Menu Operations

- 1** Press the MENU/NO button.
- 2** Turn the AMS control to select the desired menu item.
The item title will be displayed in the upper line, and the current item setting will be displayed in the lower line.
- 3** If the desired item setting is displayed, press the AMS control or the YES button.
The setting in the lower line will flash.

- 4** Turn the AMS control to change the setting (set value).
Items marked with a * in the table below changes at this step.
- 5** Press the AMS control or the YES button, to quit the setting changes.
The display will return to step 2.
The settings for items not marked with a * at this step will cancel when the MENU/NO button is pressed.
- 6** Press the MENU/NO button to quit the Setup menu.

Setup Menu Table

The Setup menu items are shown in the following table.

	Text Edit Disc/Tr Name	Enter disc name and track name.	
	TrMark/Lsync	Switch between auto track marking (level sinking) and manual track marking.	ON/OFF
	L.Sync Level	Level sink operation threshold level.	-72 dB to -48 dB (in 6dB steps)
*	COAX Level	Adjust sound level of coaxial digital input.	Mute to 0.0 dB
*	OPT Level	Adjust sound level of optical digital input.	Mute to 0.0 dB
*	ANA L/R Bal	Adjust LR balance during analog input recording.	RchMute to Center to LchMute
	Fader Time	Set fade-in/fadeout time during recording.	1 to 8 sec
*	Bass Freq	Set bass equalizer frequency.	50 Hz to 1 kHz
*	Bass Level	Set bass equalizer level.	-6 dB to 6 dB
*	Mid Freq	Set middle equalizer frequency.	100 Hz to 10 kHz
*	Mid Level	Set middle equalizer level.	-6 dB to 6 dB
*	Mid Width	Set middle equalizer bandwidth.	Narrow/Mid/Wide
*	Treble Freq	Set treble equalizer frequency.	1 kHz to 12.5 kHz
*	Treble Level	Set treble equalizer level.	-6 dB to 6 dB
*	LIM Ratio	Set limiter ratio (effective ratio).	0% to 100%
	44.1kDirect	Set recording not to use sampling rate encoder (SRC) during 44.1 kHz digital input recording.	OFF (record using SRC) ON (record without using SRC)
	Peak Hold	Set whether to leave level meter peak (maximum value) display.	ON/OFF
*	Skip/Unskip Track Edit	Set tracks to be skipped.	
	Skip Play		ON/OFF
	M.Scan Time	Set the play time for one track during music scan.	6 sec to 14 sec
	CDP RM Ctrl	Set to enable/disable CD player remote.	Disable/Enable
	Pc Keyboard	Set type of personal computer keyboard (sold separately).	JP type (Japanese keyboard) US type (English keyboard)
	▲ Mode	Set to disable tray opening during play and pause.	▶/■ Enable (Possible to open) ▶/■ Disable (Not possible to open)

Precautions

Condensation

Turning on the heating in a room when the weather is cold may cause water droplets to form inside the CD recorder. This is called condensation. If condensation occurs, normal operation will be disabled and the disc and parts may be damaged. In this case, remove the disc and leave the CD recorder to stand with the power supply turned ON for 1 hour, and then turn OFF the power and ON again before using the CD recorder normally. If normal operation is not restored even after several hours, consult the Sony Service Center.

Disc Handling Precautions

Handling Discs

- Do not touch the signal surface (the side without characters or printing) with your fingers and hands.
- Dust, scratches, and dirt may prevent normal play and recording.
- If a disc is damaged or dirtied before recording, normal recording will be disabled, so handle recording discs with greater care than normal play-only discs.
- You can delete tracks recorded on CD-RW discs and reuse the discs for recording as many times as you like, so when reusing, be sure that you can record correctly.



- Do not affix stickers to either the signal side or the printed side of the disc. The disc's center of gravity may be upset, and correct reading and writing disabled, or the CD may become stuck in the player and unable to be removed, causing damage.
- If writing the disc details or similar directly onto the surface of the label side (the side with characters or printing) of the disc, use a soft-tipped pen such as a felt pen.
- Writing forcefully with a hard-tipped pen such as a ball pen may cause damage to the recording surface, disabling the use of the disc.

Storage

- Avoid places with direct sunlight, high temperature, or high humidity, as this may cause warping or discoloring of the disc.
- Store the disc in the proper case. Placing multiple discs in one case may cause warping and scratching of the discs.

Inserting Discs

- Check that the CD is firmly inserted within the tray guides.
- Inserting the CD slanted may cause damage to the disc or the CD recorder.

Disc Maintenance

- Fingerprints, dust, and dirt may cause incorrect operation.
- Basically, take care not to dirty the signal side of the disc.
- If the disc is dirty, gently wipe the disc clean from the center outwards using a soft cloth.
- If the dirt is severe, wipe the disc gently with a soft, damp cloth, and then dry the water using a dry cloth.
- Do not use benzene, record cleaners, or static prevention solutions on the disc, as these chemicals may cause the disc to warp.

Dimensions

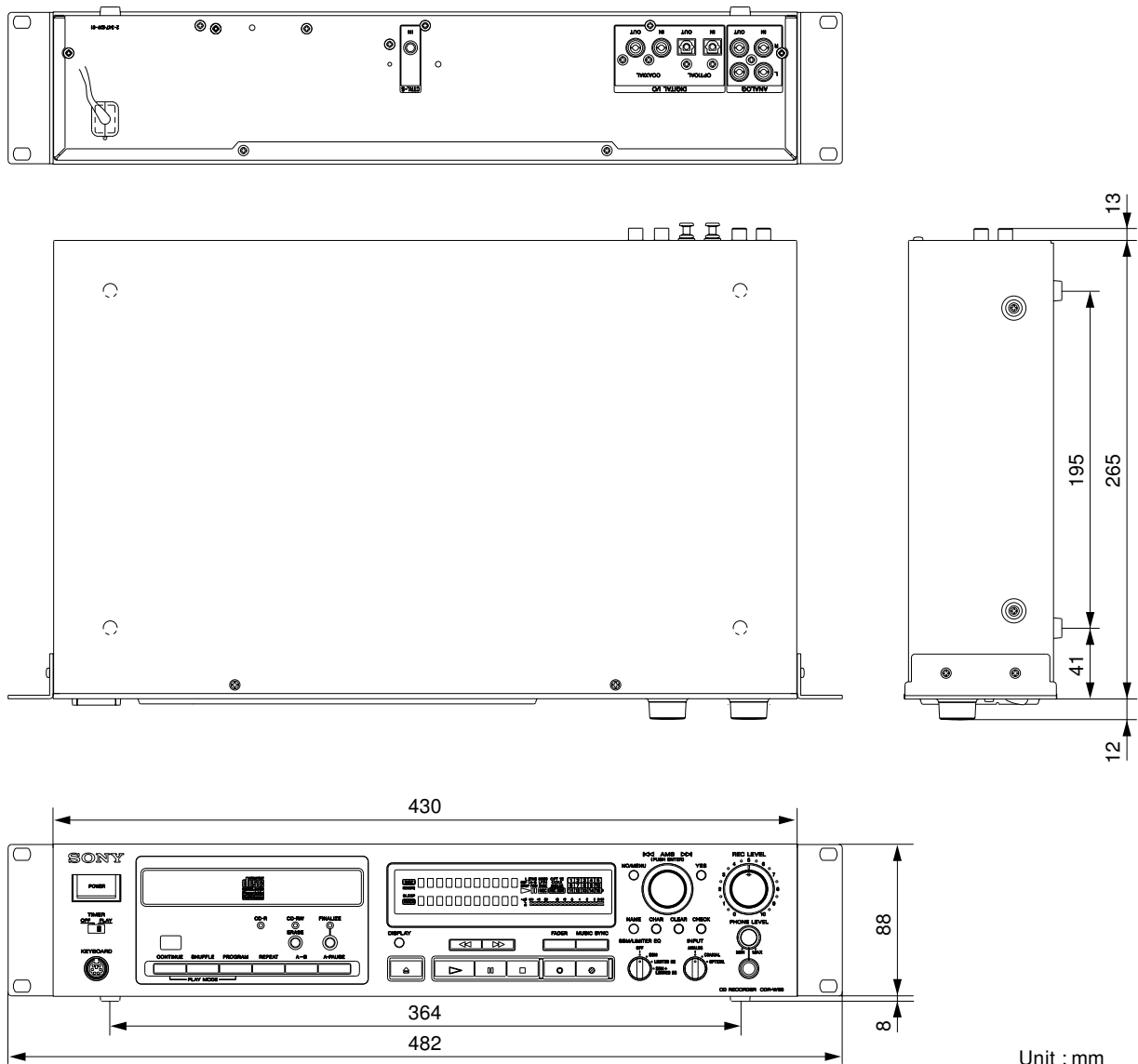

To rackmount

The unit can be mounted on EIA 19-inch rack. Move the four feet away and mount it on the rack. To move them away, pull out the plastic pins piercing them, then feet will be removed.

Specifications

Playable discs:	CD, CD-R, CD-RW
Recordable discs:	CD-R, CD-RW (for music use)
Recording method:	Track At Once (TAO)
No. of channels:	2-channel stereo
Sampling Rate Converter:	32 kHz, 44.1 kHz, 48 kHz (auto-select)
Frequency characteristics:	20 to 20,000 Hz, +0.3/−0.7 dB
Signal/Noise Ratio (S/N ratio):	98 dB (play), 92 dB (analog Rec and Play) (A-weighted)
Dynamic range:	98 dB (play), 92 dB (analog Rec and Play)
Wow and flutter*	Below measurement limits (±0.001% W. Peak).

Input Terminals

Terminal name	Terminal type	Input impedance	Basic input level	Max. input level
Analog IN	Pin jack × 2	47 kΩ	−4 dBu	+12 dBu
Digital IN	Pin jack × 1	75 kΩ	0.5 V _{p-p}	—
Coaxial	Coaxial		±20%	
Digital IN	Square connector	Optical wavelength	—	—
Optical	jack × 1	660 nm		

Output Terminals

Terminal name	Terminal type	Output level	Impedance
Analog OUT	Pin jack × 2	Max. + 8 dBu	more than 10kΩ
Digital OUT	Pin jack × 1	0.5 V _{p-p}	75Ω
Coaxial			
Digital OUT	Square connector	Rated output	—
Optical	jack × 1	−18 dBm, optical wavelength 660 nm	
Phones	Phone jack	0 to 10 mW (variable level)	32Ω

Control Terminals

Terminal name	Terminal type
Control-S IN	Mini jack × 1
KEYBOARD	Mini Din 6P × 1

0 dBu = 0.775 V

Power requirements:

Where purchased	Power requirements
U.S.A. and Canada	120VAC, 60Hz
Other countries	120V/230V AC selectable, 50/60Hz

Power consumption: 15 W

Dimensions: 482 × 88 × 265 mm (19 × 3 1/2 × 10 1/2 in.) (L × H × W) (Excluding protrusions)

Weight: 4.6 kg (10 lbs 3 oz)

Operating temperature:

5°C to 35°C

Storage temperature: −5°C to 60°C

Accessories

Operating Instructions × 1
 RM-CW1 Remote Control × 1
 R6 (size-AA) batteries × 2
 Control-S connector cord × 1

Accessories Sold Separately

Optical digital connector cable
 POC-15A or similar
 Coaxial digital connector cable
 VMC-10 or similar
 CD-R (blank disc) CRM74
 CD-RW (blank disc) CWM74

In the interests of improvement, specifications and dimensions may be subject to change without notice.

Troubleshooting

“TOC Reading” is displayed for a long time.

- ➔ The CD recorder reads CD-text-compatible characters. Consequently, it takes longer compared with players that are not CD-text-compatible.
- ➔ 30 s to 1 min. is required to read TOC information. This is not a malfunction.
- ➔ Is the disc inserted upside-down?
- ➔ Is the disc’s recording surface dirty?
- ➔ Depending on the disc, you may need to remove it and reinsert it for the disc to operate correctly.

After “TOC Reading” has been displayed, “OPC Adjust” is displayed.

- ➔ With CD-R/RW discs, laser power may need to be adjusted (OPC Adjust) when the disc is inserted for the first time, whether it is new or has been previously recorded. In this case, OPC adjust lasts for approximately 40 s.

“No Disc” is displayed, even with a disc inserted.

- ➔ Check that the disc is properly inserted between the guides (refer to page 29, “Disc Handling Precautions”).

Cannot play disc

- ➔ Is there anything recorded on the inserted disc?
- ➔ Check that the disc is a music disc (not a CD-ROM, etc.)
- ➔ Condensation (water droplets inside the CD recorder) must be considered. Remove the disc, and leave the CD recorder to stand with the power supply turned ON for 1 hour, and then turn OFF the power supply and ON again before trying to play the disc again. (Refer to page 29, Precautions.)

Cannot record to disc

- ➔ Is a play-only music CD inserted?
- ➔ Has the CD-R/CD-RW disc been finalized? (Refer to page 18, “Finalizing”).
- ➔ Are there already 99 tracks recorded on the disc? (Refer to page 11, “Recording Precautions”).
- ➔ Is the Recordable space on the disc full? (Refer to page 11, “Recording Precautions”).
- ➔ Is the source device connected correctly? (Refer to page 5, “Connections”).
- ➔ Is the INPUT switch selection correct? (Refer to page 10, “Recording on a disc”).
- ➔ Is the recording level set too low? (Refer to page 12, “Adjusting the Recording Level”).
- ➔ Are you trying to record on a recordable disc?

The recorded data does not stay on the disc.

- ➔ If the power supply is turned OFF during recording or while PMA Writing is displayed, writing to the PMA area will be incorrect, and the recording disabled. (Refer to page 11, “Recording Precautions”).

Cannot add track numbers, even pressing the ● button during recording.

- ➔ Check if auto track marking is ON (L.SYNC is lit). (Refer to page 12, “Adding Track Numbers (Track Marking)”).

Cannot play recorded discs on other CD players.

- ➔ Has the disc been finalized? (Refer to page 18, “Finalizing”).
- ➔ Is the disc dirty or damaged? (Refer to page 29, “Precautions”).
- ➔ Even if the CD-RW disc is finalized, a CD-RW disc cannot be played on a CD player that is not CD-RW-compatible. (Refer to page 18, “Finalizing”).

Even though the parameters have been set, the limiter and equalizer effects are not operating.

- ➔ Set the SBM/LIMITER/EQ switch to LIMITER + EQ or SBM + LIMITER + EQ. (Refer to page 15, “Using the Digital Limiter and Digital Equalizer”).
- ➔ Limiter and equalizer effects are enabled for analog recordings only. They are disabled during play and for digital recordings.
- ➔ SBM is very delicate, so if monitoring using headphones, depending on your system, the effects may not be recognizable.

Cannot use the remote for operations.

- ➔ Have the remote’s batteries worn down? (Refer to page 5, “Inserting Batteries into the Remote”).
- ➔ Is there any obstruction between the remote and the CD recorder? (When using the wireless remote.)
- ➔ Is the sensor aimed at the CD recorder? (When using the wireless remote.)
- ➔ Is the supplied cable attached to either the CD recorder or the remote? (When using the wireless remote.)

The disc name and track name that were entered have been erased.

- ➔ If the power supply is turned OFF or the disc removed before being finalized, the entered names will be erased. (Refer to page 18, “Finalizing”).

Display Messages

Message	Meaning
No Disc	Disc has not been inserted.
0Tr 0M00s	Time display when unrecorded disc is inserted.
TOC Reading	Disc TOC information is read immediately after a disc is inserted.
OPC Adjust	Optimizing laser power for recording.
Disc Error	Disc is not inserted correctly. Cannot read disc information correctly.
PMA Writing	Recording to PMA (Program Memory Area). Displayed after recording is stopped or skip setting is verified. Do not turn OFF the power supply while this message is displayed.
SkipPmaFull	PMA skip/unskip area is full. Cannot record new information.
Text Edited sure ▲?	This message is a warning that although a disc name or track name has been entered, you are trying to remove the disc without finalizing. Press the ▲ button again within 4 seconds to remove the disc. All entered information will, however, be lost. To store the name data, finalize the disc before removal.
Disc Full	No more can be recorded on the disc.
Finalized	Disc has been finalized, so no more tracks can be recorded.
Tno Full	The maximum number of tracks (99) have been recorded, so no more tracks can be recorded.
Cannot Rec	CD is play-only, so recording is not possible, or REC MUTE has been set at the start of the unrecorded tracks.
Cannot Erase	CD is play-only, or is a CD-R (tracks cannot be erased).
No Track	Playing an unrecorded disc, or a disc on which all tracks have been set to skip.
Cannot Copy	Signal is not consumer digital audio format.
Din Unlock	Power supply is turned OFF to the recording source, or is not correctly connected.
Auto Pause	Auto-pause function is ON, and CD recorder is in standby mode.
Timer Play	Timer play function has turned ON when the power supply was turned ON, and CD recorder is in play mode.
Open Lock	▲ mode is set to ►/ Disable, and the ▲ button has been pressed during play or pause.
Skip Track	The selected track has been set to skip.
Cannot Mark Now L.Sync	Attempting to mark track number manually while auto track marking has been set.
OPC Full	OPC recording area is full. Cannot perform OPC Adjust.
PMA Full	PMA recording area is full. (refer to page 21)
Rec Error	Error has occurred due to shock during recording.

