

Turbomolecular Pumps
With Electronic Drive Unit TC 600



TPH 521 P C
TPU 521 P C

PT 0155 BE/C (0503)

	Page		Page
1. Safety Instructions	3	4.9. Operations With The Remote Control Unit.....	20
1.1. For Your Orientation.....	3	Venting Release (Optional).....	20
1.2. Pictogram Definitions.....	3	Motor, Turbopump	20
2. Understanding The Pumps		Pumping Station	20
TPH/TPU 521 P C	4	Heating/Reset	20
2.1. Main Features.....	4	Standby.....	20
Proper Use	4	Rotation Speed Setting Operations	
Improper Use	5	Via Input PWM	20
2.2. Differences Between The Pump Types.....	5	Switching Outputs.....	20
2.3. Scope Of Delivery	5	5. Monitoring Operations.....	21
3. Installation	6	5.1. Operations Display Via LED.....	21
3.1. Preparations For Installation.....	6	5.2. Turbopump Temperature Monitoring	21
3.2. Installing The Pump,		6. What To Do In Case	
Connecting The High Vacuum Side	6	Of Breakdowns?.....	22
3.3. Connecting The Fore-Vacuum Side	9	7. Maintenance/Replacement	23
3.4. Connecting The Cooling Unit.....	10	7.1. Replacing The Lubricant.....	23
3.5. Connecting The Venting Valve.....	11	7.2. Cleaning The Lubricating Pump.....	23
3.6. Connecting The Casing Heating Unit.....	11	7.3. Replacing The Electronic Drive Unit TC 600	24
3.7. Connecting The Sealing Gas Valve.....	11	8. Service	25
3.8. Installing The Cover Plate For The TC 600	12	9. Technical Data	26
3.9. Connecting The Electronic Drive Unit TC 600.....	13	9.1. Dimensions Diagram	27
3.10. Installing The Power Unit	13	10. Accessories	31
3.11. Connecting The Remote Control Unit	14	10.1. Lubricant.....	31
3.12. Connecting The Serial Interface RS 485	15	11. Spare Parts	32
Connection	15	Declaration of Contamination	33
Connecting The RS 485	15	Manufacturer's Declaration	(last page)
3.13. Connections Diagram.....	16		
4. Operations	17		
4.1. Filling In The Lubricant.....	17		
4.2. Before Switching ON.....	17		
4.3. Switching ON.....	18		
4.4. Gas Type Dependent Operations	18		
4.5. Circulatory Lubrication.....	19		
4.6. Switching OFF And Venting.....	19		
4.7. Shutting Down For Longer Periods	19		
4.8. Operations With The DCU 001,			
DCU 300 or HPU 001	19		

Please note: Current operating instructions are available via www.pfeiffer-vacuum.net.

1. Safety Instructions

- ☞ Read and follow all instructions in this manual.
- ☞ Inform yourself regarding:
 - Hazards which can be caused by the pump;
 - Hazards which can be caused by your system.
 - Hazards which can be caused by the media being pumped.
- ☞ Avoid exposing any part of the body to vacuum.
- ☞ Observe the safety and accident prevention regulations.
- ☞ Regularly check that all accident prevention measures are being complied with.
- ☞ Do not operate the turbopump with open high vacuum flange.
- ☞ Do not carry out any unauthorised conversions or alterations to the turbopump with TC 600.
- ☞ When returning the turbopump observe the shipping instructions.
- ☞ The turbopump must be anchored in accordance with the installation instructions (Sec. 3).
- ☞ Do not disconnect the plug between the TC 600 and accessory components during operations.
- ☞ Before opening the turbopump disconnect the voltage supply to the TC 600.
- ☞ When working on the turbopump, the high vacuum flange should only be opened once the rotor is at rest.
- ☞ When using sealing gas, the pressure in the hose connection should be limited to 2 bar via the overpressure valve.
- ☞ If a heater is in use temperatures of up to 120 °C can arise in the area of the high vacuum flange. Take care to avoid burns!
- ☞ During operations temperatures of up to 65 °C can arise in the lower part of the turbopump. Take care to avoid burns!
- ☞ Keep leads and cables well away from hot surfaces (> 70 °C).
- ☞ Operate the turbopump with TC 600 only in conjunction with the relevant Power Pack Unit (accessory).
- ☞ Without the cover plate for the TC 600 the unit has been accredited protection class IP 30. When the unit is operated in environments which require other protection classes, the necessary measures must be taken. When the turbopump is water cooled the enclosed cover plate for the TC 600 must be installed by an electrical specialist, in order to attain protection class IP 54.
- ☞ The mains connection must be subject to a safe connection to the PE (protection class 1).
- ☞ If the turbopump and the TC 600 are operated separately (only permissible with the agreement of the manufacturer) the turbopump must be connected to the PE.
- ☞ The turbopump and the TC 600 must only be disconnected from each other when the turbopump is completely at rest and the TC 600 has been disconnected from the power supply.
- ☞ The cause of any operating voltage leakage to earth (red LED flashes) must be eliminated to avoid the danger of an electric shock.
- ☞ The housing screws do not loosen, pull tight, remove or replace, since otherwise the guarantee for the security of the turbopump expires.

1.1. For Your Orientation

Instruction in the text

➔ Working instruction: here, you have to do something.

Symbols used

The following symbols are used throughout in illustrations:

- ⊕ High vacuum flange
- ⊖ Fore-vacuum flange
- ⊞ Venting connection
- ⊗ Cooling water connection
- ⊕ Air cooling
- ⚡ Electric connection
- ⊕ Sealing gas connection

Abbreviations used

DCU = Display and operating unit
 HPU = Display and operating unit
 TC = Electronic drive unit, turbopump
 TPS = Power unit

Position numbers

The same pump and accessory parts have the same position numbers in all illustrations.

1.2. Pictogram Definitions



Warning, danger of burns from touching hot parts.



Warning, danger of personal injury.



Caution, danger of damage to the pump or to the system.



Warning, danger of injury from rotating parts.



Please note, attention to particularly important information on the product, handling the product or to a particular part of the documentation.

2. Understanding The Pumps

2.1. Main Features

Turbopumps with the TC 600 form a complete unit. Voltage is supplied by Power Unit TPS (see "Accessories").



On delivery, the pumps have been set up for operations in remote mode. Remote plug 8d should therefore be disconnected if operations with the DCU 001, DCU 300 or HPU 001 are required.

Turbomolecular Pump TPH/TPU 521 P C

- 1 High vacuum flange
- 2 Fore-vacuum flange
- 3 Cooling water connection
- 4 Venting screw/venting valve connection
- 8 Electronic Drive Unit TC 600
- 8d Remote plug
- 9 Sealing gas connection
- 71 Lubricant filler screw
- 72 Lubricant drain screw
- 73 Sight glass

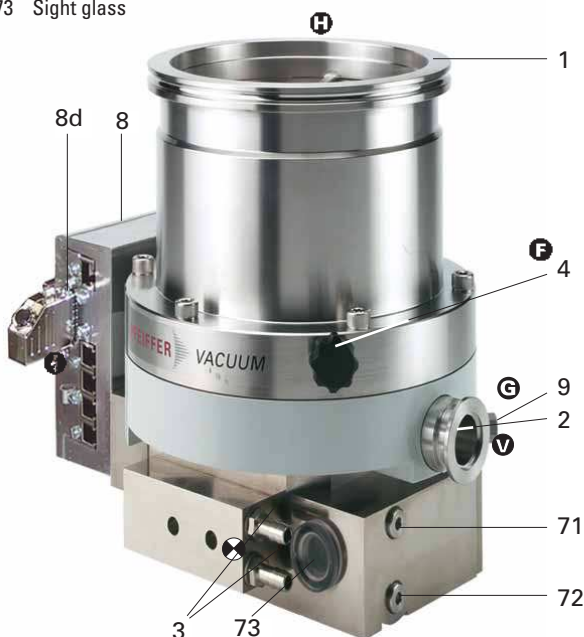

Cooling

Standard: Water cooling

Integrated protective measures against excess temperatures:

The Electronic Drive Unit TC 600 reduces the rotor rotation speed.

Bearings

High vacuum side: Wear free permanent magnetic bearing.

Fore-vacuum side: Oil circulatory lubricated ball bearing with ceramic balls.



The turbopumps must **not** be transported when filled with lubricant.

When being fitted into or dismantled from a system, turbopumps may **only be positioned as shown in Section 3.2.** Other positions can cause the pumps to be contaminated with lubricant.

Ambient conditions

The turbomolecular pump needs to be installed in compliance with the following ambient conditions:

Installation location:	protected against the weather (rooms within buildings)
Temperature:	+5 °C to +40 °C
Relative humidity of the air:	max. 80 % at $T \leq 31$ °C up to max. 50% at $T \leq 40$ °C
Air pressure:	77 kPa - 106 kPa
Installation altitude:	2000 m max.
Pollution degree:	2
Overvoltage category:	II
Connection voltage:	72 VDC $\pm 5\%$

Proper Use

- The Turbomolecular Pumps may only be used for the purpose of generating vacuum.
- The Turbomolecular Pumps are designed to pump corrosive gases and vapours. Where corrosive gas processes are involved, gas bonding and particles which can damage the surfaces of the pump can be produced. The motor and bearing compartments have to be protected with sealing gas.
- The turbopumps may only be used to pump those media against which they are chemically resistant. For other media the operator is required to qualify the pumps for the processes involved.
- If the process produces dust, the maintenance intervals must be specified accordingly and sealing gas must be used.
If the pump is to be operated with more than 50% of the permissible gas load then sealing gas should be used to ensure rotor cooling.

- The turbopump must be connected to a backing pump in accordance with Section 3.3.
- Only Pfeiffer Vacuum power units may be used to operate the TC 600. The use of other power units requires the prior agreement of the manufacturer and equalization with the valid specification.
- Without the cover plate for the TC 600 the pumps may only be operated providing the ambient conditions in compliance with Protection Type IP 30 are observed.

Improper Use

The following is regarded, inter alia, as improper:

- The pumping of explosive gases.
 - Operating the pumps in areas where there is a danger of explosion.
 - Operating the pumps in areas where there is a danger of radioactivity.
 - The pumping of gases and vapours which attack the materials of the pumps.
 - The pumping of corrosive gases without sealing gas.
 - The pumping of condensating vapours.
 - Operations with improper gas modes.
 - Operations involving impermissibly high levels of gas loads.
 - Operations with impermissibly high fore-vacuum pressure.
 - Operations involving too high levels of heat radiation power (see Section 9. "Technical Data").
 - Venting with rates higher than in Section 4.6. stated.
 - Operating the pump without the cover plate for the TC 600 in environments which require a protection class superior to IP 30.
- Installation of the pumps in systems where the turbomolecular pumps are subjected to impact-like stress and vibrations or the effect of periodically occurring forces.
- The use of other power units or accessories which are not named in this manual or which have not been agreed by the manufacturer.
 - The connection to power units with earthing of a direct voltage pole.

The turbomolecular pumps and flange connections must not be used to tread on when climbing onto the system.

Improper use will cause all claims for liability and guarantees to be forfeited.

2.2. Differences Between The Pump Types

Feature	TPH 521 P C	TPH 521 P C	TPU 521 P C
HV-flange	DN 100 ISO-K DN 160 ISO-K	DN 100 ISO-F DN 160 ISO-F	DN 100 CF-F DN 160 CF-F
HV-seal	Elastomer	Elastomer	Metal
Attainable final pressure (out)	$< 1 \cdot 10^{-8}$ mbar (without baking-out)	$< 1 \cdot 10^{-8}$ mbar (without baking-out)	$< 5 \cdot 10^{-10}$ mbar (with baking-out)

Abbreviations on the Type plate of the pump

TPH/TPU 521 P C

- Suffix "P": Purge gas connection for the prevention of the ingress of aggressive gases into the motor and bearing area
- Suffix "C": Surface protection for passive protection of the pump

2.3. Scope Of Delivery

The turbopump scope of delivery includes:

- Lubricant F3 (35 ml) with filling syringe,
- cover plate for the TC 600 to fulfilled the conditions for protection class IP 54 (please see Section 3.8.),
- protective covering for the high vacuum flange and the fore-vacuum flange.



The 4 screws at the High vacuum flange are not sufficient for the attachment of the pump at a recipient (see Section 3.).

3. Installation

3.1. Preparations For Installation



Do not carry out any unauthorised conversions or alterations to the turbopump.



In case the rotor blocks suddenly, torque levels up to **6690 Nm** can occur which need to be absorbed by the system and the high vacuum flange.



The turbopumps must not be transported when filled with lubricant.

- Pumps must be filled with lubricant before being operated (see Section 4.1.).
- If the turbopump is to be operated with the DCU 001 or HPU 001, the remote plug 8d (please see Section 2.1.) on the TC 600 should be disconnected and then proceed in accordance with the corresponding operating instructions.
- The maximum permissible rotor temperature of the pump is 90 °C. If the vacuum chamber or parts in the vacuum chamber are heated, the values stated in the technical data relating to the level of heat which may be radiated into the pump must not be exceeded. If necessary, suitable shielding must be fitted in the vacuum chamber before the turbopump (constructional suggestions available on request).
- The temperature of the high vacuum flange must not exceed 120 °C.
- Only remove the blank flange from the high and for-vacuum side immediately before connection.
- Where magnetic fields of > 5.0 mT are involved suitable shielding must be provided (available on request).
- If the pump is baked out, the heating sleeve and the body of the pump must be insulated to prevent burns from accidental contact.
- Floor mounting of the turbomolecular pump is only admissible after consulting the manufacturer.



The person responsible for commissioning must ensure that the installation is carried out in accordance with the legal regulations and the pertinent industrial standards.

3.2. Installing The Pump, Connecting The High Vacuum Side



The utmost cleanliness must be observed when fitting all high vacuum parts. Unclean components prolong the pumping time. All installations units for the flange must be with installation grease-free, dust free and drying.

Use a Pfeiffer Vacuum splinter shield or protective mesh

The use of a Pfeiffer Vacuum splinter shield or protective mesh in the high vacuum flange protects the turbopump against foreign bodies coming from the vacuum chamber but does reduce the volume flow rate as followed:

		Reduced volume flow rate in %		
		N ₂	Ar	CF ₄
Splinter shield	DN 100	20	23	28
	DN 160	14	16	20
Protective mesh	DN 100	6	7	8
	DN 160	4	4	6

Connecting via bellows or Pfeiffer Vacuum vibration compensator (Accessory)

The high vacuum side can be flanged onto the vacuum chamber either directly or via a bellows or a vibration compensator (please see Sec. 10. "Accessories").

When using a Pfeiffer Vacuum vibration compensator, suitable securing needs to be introduced capable of absorbing the energy of the rotor should it suddenly block, since the vibration compensator itself alone cannot absorb the occurring forces. Please consult the manufacturer.



The maximum permissible temperature at the vibration compensator is 100 °C.

Installing the high vacuum flange

- In case the rotor blocks suddenly, torque levels up to **6690 Nm** can occur which need to be absorbed by the system and the high vacuum flange.
- For installing the turbomolecular pumps to the high vacuum flange, the components listed in the following **must** be used exclusively. Otherwise the turbomolecular pump may twist or tear off. The components for installing the turbomolecular pumps are special designs from Pfeiffer Vacuum
- The minimum strength of 170 N/mm² of the flange material needs to be observed.

Installation is done as follows.



To reliably prevent the pump from twisting if the rotor suddenly blocks, it is absolutely prohibited to secure a pump with an ISO-K flange on a vacuum chamber with an ISO-F flange or vice versa. Both flanges **must be** of the same type. Installation with different flange types is carried out at the user's own risk. Pfeiffer Vacuum shall assume no liability whatsoever for any damage or injuries resulting from this kind of attachment.

ISO-K to an ISO-K flange

For installation, the following components are available.

Connection nominal-diameter	Designation	Order-number
DN 100 ISO-K/ DN 100 ISO-K	Centering ring (coated)	PM 016 210 AU
	Centering ring (coated) with splinter shield	PM 016 211 AU
	Centering ring (coated) with protective mesher	PM 016 212 AU
	Bracket screws (16 pieces must be used)	PF 300 110 -T
DN 160 ISO-K/ DN 160 ISO-K	Centering ring (coated)	PM 016 216 AU
	Centering ring (coated) with splinter shield	PM 016 217 AU
	Centering ring (coated) with protective mesher	PM 016 218 AU
	Bracket screws (14 pieces must be used)	PF 300 110 -T

Bracket screw

- A ISO-K flange
- B Bracket screw
- C Centering ring, coated
- D Splinter shield
- E Protective mesh

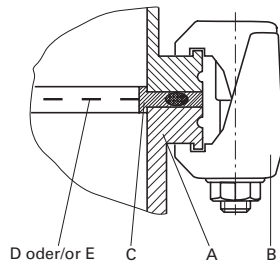

- ➔ The clamps need to be tightened crosswise in three steps. Tightening torque: 5 Nm, 15 Nm, 25 ±2 Nm

ISO-F to an ISO-F flange

For installing there exist three variants.

Variant 1 - Hexagon screw with blind hole

Connection nominal-diameter	Designation	Order-number
DN 100 ISO-F	Centering ring (coated)	PM 016 210 AU
	Centering ring (coated) with splinter shield	PM 016 211 AU
	Centering ring (coated) with protective mesher	PM 016 212 AU
	Hexagon screws with washer (8 pieces each must be used)	N 3024 428 1C N 3502 422 4P
DN 160 ISO-K/ DN 160 ISO-K	Centering ring (coated)	PM 016 216 AU
	Centering ring (coated) mit Splitterschutz	PM 016 217 AU
	Centering ring (coated) mit Schutzgitter	PM 016 218 AU
	Hexagon screws (8 pieces must be used)	N 3024 479 1C

Hexagon screw with blind hole

- A ISO-F flange
- B Hexagon screw¹⁾
- C Centering ring, coated
- D Splinter shield
- E Protective mesh

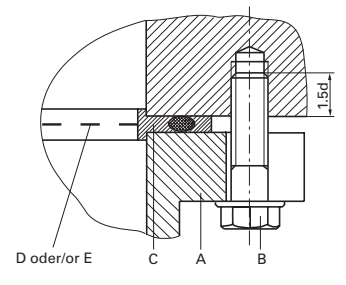

1) DN 100 ISO-F with washer

- ➔ For a flange material having a strength of > 270 N/mm² and with a blind hole the hexagon screw 1,5 d must be screwed in. The hexagon screws must be tightened crosswise in three steps.

Tightening torque:

DN 100 ISO-F: 5 Nm, 12 Nm, 22 ±2 Nm
DN 160 ISO-F: 10 Nm, 20 Nm, 38 ±3 Nm

Variant 2 - Stud screw with blind hole

Connection nominal-diameter	Designation	Order-number
DN 100 ISO-F	Centering ring (coated)	PM 016 210 AU
	Centering ring (coated) with splinter shield	PM 016 211 AU
	Centering ring (coated) with protective mesher	PM 016 212 AU
	Stud screws (8 pieces must be used)	N 3169 428 2C
	Nuts with washer (8 pieces each must be used)	N 3433 047 8P N 3502 422 4P
DN 160 ISO-F	Centering ring (coated)	PM 016 216 AU
	Centering ring (coated) with splinter shield	PM 016 217 AU
	Centering ring (coated) with protective mesher	PM 016 218 AU
	Stud screws (8 pieces must be used)	N 3169 485 2C
	Nuts (8 pieces must be used)	N 3433 051 8P

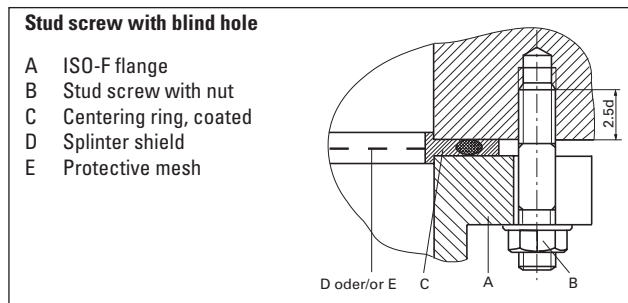

1) DN 100 ISO-F with washer

➔ For a flange material having a strength of 170-270 N/mm² and a screw-in flange, the stud screw 2,5 d must be screwed in. The nuts must be tightened crosswise in three steps.

Tightening torque:

DN 100 ISO-F: 5 Nm, 12 Nm, 22 ±2 Nm

DN 160 ISO-F: 10 Nm, 20 Nm, 38 ±3 Nm

Variant 3 - Stud screw and clearance hole

(components as for variant 2; 16 pieces of nuts must be used)

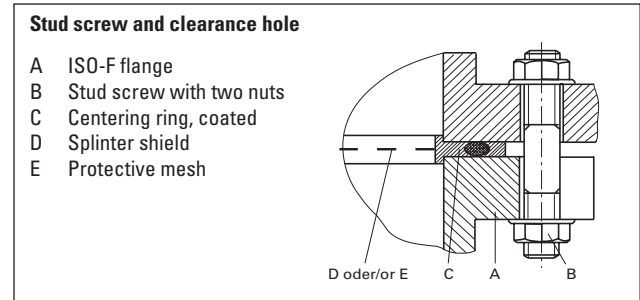

➔ For a flange material having a strength of > 170 N/mm² and a stud screw with clearance hole, the nuts must be tightened crosswise in three steps.

Tightening torque:

DN 100 ISO-F: 5 Nm, 12 Nm, 22 ±2 Nm

DN 160 ISO-F: 10 Nm, 20 Nm, 38 ±3 Nm

CF-F flange

Applications for installing an CF-F to an CF-F flange:

Stud screw with blind hole

16 (DN 100 CF-F) or 20 (DN 160 CF-F) pieces of stud screws (M8) with washers and nuts must be used. The stud screws need to be tightened revolving with a tightening torque of 22 ±2 Nm.

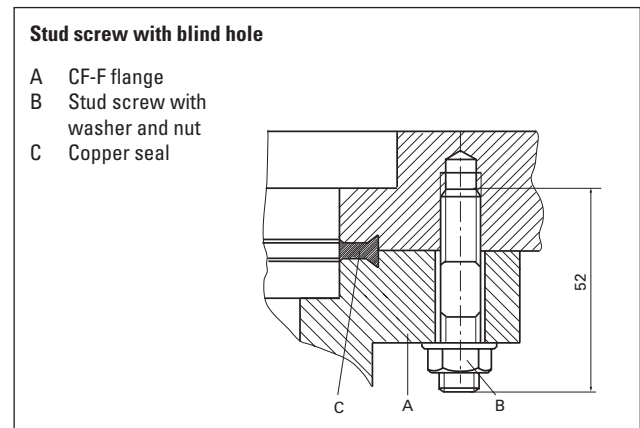

Hexagon screw and clearance hole

16 (DN 100 CF-F) or 20 (DN 160 CF-F) pieces of hexagon screws (M8) with washers and nuts must be used. The hexagon screws need to be tightened revolving with a tightening torque of 22 ±2 Nm.

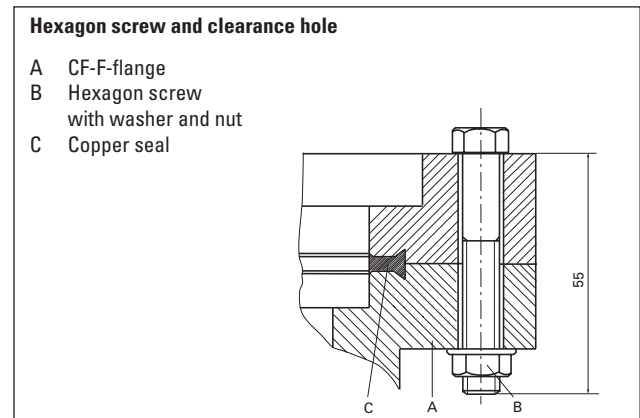

The components for installing to an CF-F flange are to be ordered under the following numbers:

Connection nominal-diameter	Designation	Order-number
DN 100 CF-F DN 160 CF-F	Hexagon screw M8 with washer and nut (25 pieces) ¹⁾	PF 505 003 -T
	Stud screw M8 with washer and nut (22 pieces) ¹⁾	PF 507 003 -T
DN 100 CF-F	Copper seal (10 pieces) ¹⁾ or copper seal silvered (10 pieces) ¹⁾	PF 501 410 -T PF 501 510 -T
	Splinter shield ²⁾	PM 016 315
	Protective mesh ²⁾	PM 016 336
DN 160 CF-F	Copper seal (10 pieces) ¹⁾ oder copper seal silvered (10 pieces) ¹⁾	PF 501 416 -T PF 501 516 -T
	Splinter shield ²⁾	PM 016 318
	Protective mesh ²⁾	PM 016 339

1) supplied pieces

2) Insert the splinter shield and protective mesh in the high vacuum flange with the clamping lugs downward.

Directly flanging the pump

The turbopump can be flanged onto the vacuum chamber vertically (0°) up to an angle of 90° maximum.



The fore-vacuum flange must always point downwards.

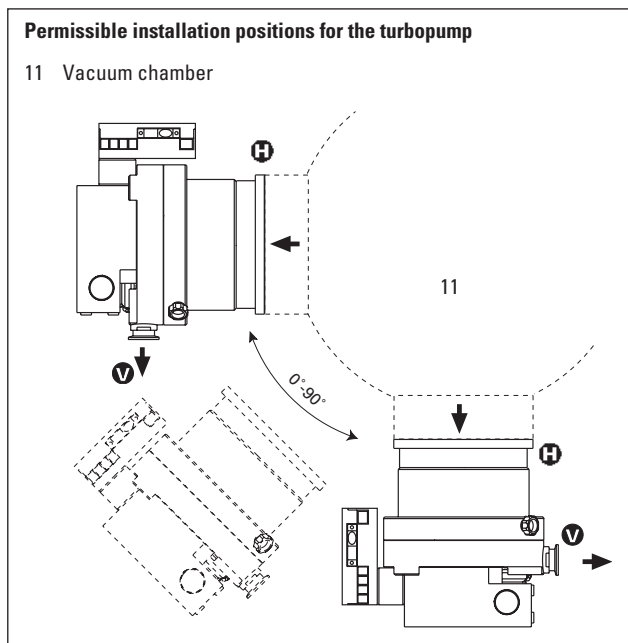

The loading capacity of the high vacuum flange is max. 1000 N (equivalent to 100 kg). Asymmetric loading on the high vacuum flange must be avoided.

If the pump is being installed horizontally:

The fore-vacuum flange of the turbopump must be aligned vertically downwards (maximum deviation $\pm 20^\circ$), otherwise the turbopump could become dirty and the lubricating pump not properly function.

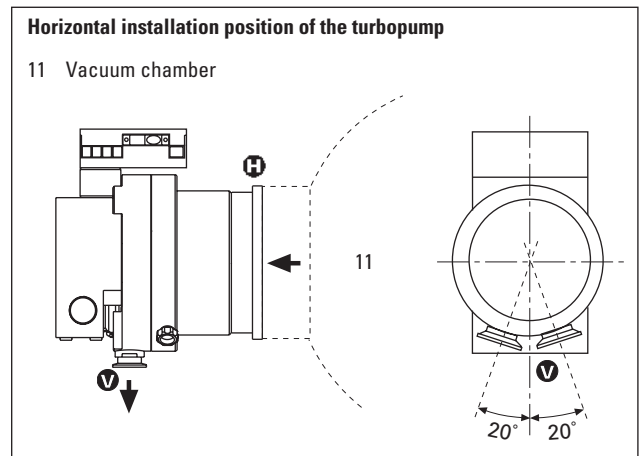

No forces from the piping system must be allowed to act on the pump where turbopumps are anchored. Suspend or support all pipes to the pump.

3.3. Connecting The Fore-Vacuum Side

Backing pump: Fore-vacuum pressure please refer to Section 9. Technical Data.

Recommendation: Dry backing pump or Rotary vane vacuum pumps from the Pfeiffer Vacuum range.

Connecting the backing pump

All connections of the fore-vacuum line: With the usual small flange components or screwed hoses.



Be sure to conduct away the exhaust gases from the backing pump. Do not reduce the free cross section of the fore-vacuum flange with following components.



The exhausted process gases and vapours can represent a health hazard and can also be environmentally damaging. Comply with all the gas manufacture's safety instructions.

- ➔ With rigid pipe connections: Fit a bellows in the connecting line to reduce vibration.
- ➔ The electrical connection of the backing pump is made via a relay box (see Section 10. Accessory) whose control line is connected to "FV PUMP" on the TC 600.

Please refer to Operating Instructions PT 0030 BN for details on the relay box, backing pump and its installation.

3.4. Connecting The Cooling Unit

The Turbopumps TPH/TPU 521 P C are water cooled as standard.



When the turbopump is water cooled the enclosed cover plate for the TC 600 must be installed by an electrical specialist, in order to attain protection class IP 54 (please see Section 3.8.).

Water Cooling



The cooling water connections referred to here are in respect to the standard version turbopump.

The cooling water can be drawn either

- From the cooling water mains, or
- From Recycled Water Cooling Unit TZK in closed circuit.

Cooling from the cooling water mains

To prevent deposits collecting in the pump the cooling water must be filtered.

Minimum cooling water requirements:

Mechanically clean, optically clear, no turbidity, no sediment, chemically neutral, temperature > dew point.

Oxygen content:	max. 4 mg/kg
Chloride content:	max. 100 mg/kg
Carbonate hardness:	max. 10 ° dH
Consumption of potassium permanganate:	max. 10 mg/kg
Carbon dioxide:	Undetectable
Ammonia:	Undetectable
pH-value:	7 – 9
Max. fore-line over pressure:	max. 6 bar
Minimum flow rate at gas load max.:	100 l/h at 15 °C

Connection to the cooling water mains

- ➔ Fit the dirt trap (Accessory) in the supply line.
- ➔ Connect the supply line (31) with hose clips onto one of the two cooling water connections.
- ➔ Connect the return line (32) to the other cooling water connection of the turbopump.
- ➔ Tighten the cooling water connection to a torque of 10 Nm.
- ➔ Tighten all hose clips and check for firm seating of the hoses.

Cooling from the cooling water mains

- 3 Cooling water connection
- 31 Supply line
- 32 Return line
- 33 Dirt trap

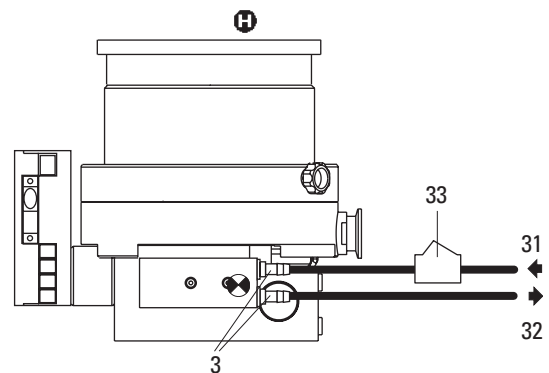

Cooling With The Recycled Water Cooling Unit TZK (Accessory)

Connection to the TZK

Dirt traps are not permissible in the lines.

All other steps as for connecting to the cooling water mains.

Cooling with Recycled Water Cooling Unit TZK

- 3 Cooling water connection
- 31 Supply line
- 32 Return line
- 35 Recycled Water Cooling Unit TZK

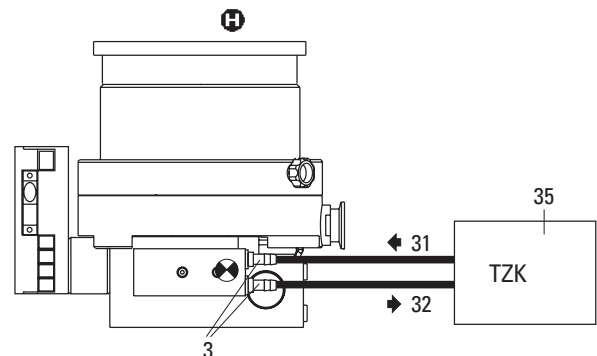

3.5. Connecting The Venting Valve

The venting valve TVF 005 (please see Section 10. Accessory) provides automatic venting in the event of a power failure and switching off.

Fitting the venting valve

- ➔ Unscrew the venting screw 4 (please see Section 2.1.) from the venting connection of the turbopump.
- ➔ Screw in venting valve 42 with seal (USIT ring) on hexagonal SW 14.

Electrical connection

- ➔ Plug control lead 42a into the connection "VENT" of the TC 600 (8) on the turbopump.

The venting mode of the venting valve is selected via the DCU/HPU or Serial Interface RS 485.

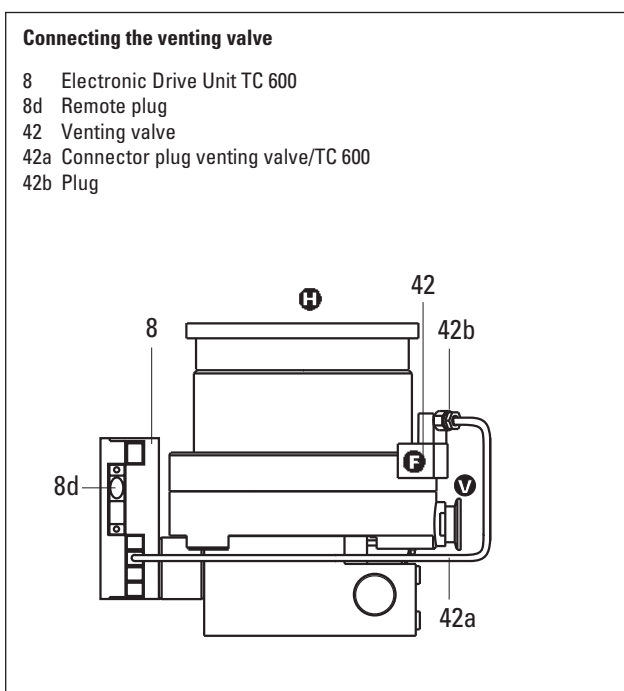

The maximum pressure at the venting valve is 1.5 bar absolute.

Please refer to Operating Instructions PM 0507 BN for details on Venting Valve TVF 005.

3.6. Connecting The Casing Heating Unit

Heating turbopumps and vacuum chambers accelerates the attainment of final pressures. The heating period is dependent on the level of contamination and the required final pressure. Heat for at least four hours.



High temperatures are generated when turbopump or vacuum chamber are baked out. Contact with hot parts can cause burns, even when the casing heating has been switched off. Heating sleeves, pump casing and vacuum chamber should be insulated when fitting. Do not touch heating sleeves, pump casing and vacuum chamber during baking out.

Please refer to Operating Instructions PM 0542 BN for details on the casing heating unit and its installation.

3.7. Connecting The Sealing Gas Valve

To protect the pump, particularly where corrosive or dust producing processes are involved, it is necessary to use sealing gas. Connection is made via the sealing gas valve (please see Section 10. Accessories).

Please refer to Section 9.1. Dimensions Diagram for the sealing gas connection.

Please refer to Operating Instructions PM 0229 BN for details on installing the sealing gas valve and adjusting the sealing gas flow.

3.8. Installing The Cover Plate For The TC 600

The turbomolecular pump with integrated Electronic Drive Unit TC 600 has an IP 30 protection class rating.

When the turbopump is water cooled the enclosed cover plate for the TC 600 must be installed by an electrical specialist, in order to attain protection class IP 54



Before installing the cover plate, the Electronic Drive Unit TC 600 must be disconnected from the power supply. The speed of the turbomolecular pump must be 0 Hz.



Before beginning with any installation work involving the cover plate for the Electronic Drive Unit TC 600, the remote plug 8d (see Section 2.1.) must be removed. When using the remote plug, the cover of the remote plug must be unscrewed from the remote plug.

- ➔ First the cable clamp must be removed from the TC 600.
- ➔ Thereafter unscrew the 3 cylinder head screws with slot (M3) from the TC 600.
- ➔ Bolt the bottom section 107a to the TC 600 with the hexagon socket screws 107b (3 pieces). The sealing surface must rest against the TC 600.
- ➔ Insert the O-ring 107c into the bottom section.

Installing the bottom section

8	Electronic Drive Unit TC 600
107a	Bottom section
107b	Hexagon socket screw (3 pieces)
107c	O-ring

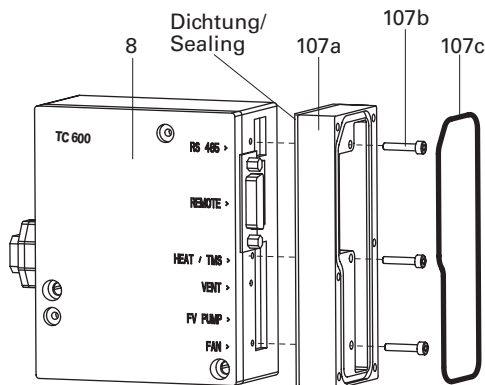

- ➔ First pull the corresponding cables through the inserts with screwed cable glands and the cover 107d and insert the cables at the TC 600.

In case the pump is operated using the remote control, the remote control unit must be connected in accordance with Section 3.11 and the wiring diagram (Section 3.13).

Inserts and Screw fittings

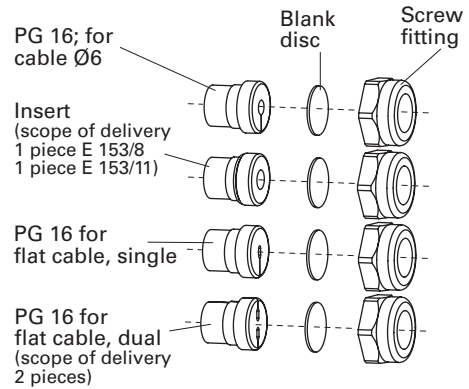

The cable arrangement is as follows:

- Accessories (venting valve, backing pump) in PG 16 with flat cable (single or dual)
- Interface cable RS 485 in PG 16; for cable Ø 6
- Connecting cable for remote control etc. in insert E 153/8 or E 153/11.

- ➔ Thereafter screw the cover 107d to the bottom section 107a with the screws 107e (6 pieces). Particularly ensure that the O-ring 107c is properly seated!

Installing the cover

8	Electronic Drive Unit TC 600
107a	Bottom section
107c	O-ring
107d	Cover
107e	Screw (6 pieces)

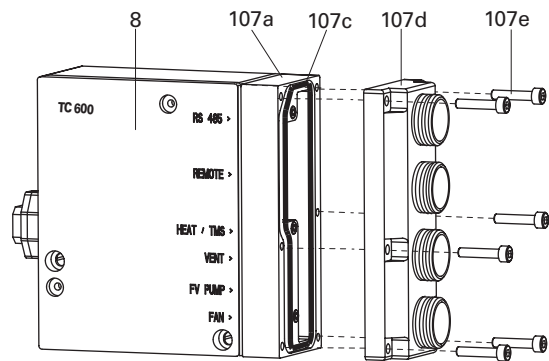

- ➔ Firmly tighten the screwed cable glands at the cover 107d.



If a cable feedthrough remains unoccupied, a blank disc must be inserted instead of the cable.

After installing the cover plate, the requirements of protection class IP 54 are fulfilled. The turbomolecular pump may then be operated once more.

3.9. Connecting The Electronic Drive Unit TC 600



The turbopump and the Electronic Drive Unit TC 600 are connected and together form a single unit. Connecting cable 8a has to be ordered separately (see Section 10. Accessories).

- ➔ Unscrew screw with tooth lock 8c from the TC 600 (above the connection X4).¹⁾
- ➔ Plug the plug X4 on connecting cable 8a into the connection X4 on the TC 600 and screw in screw 8b.
- ➔ Secure plug X4 on the TC 600 with a screw and tooth lock 8c.¹⁾
- ➔ Connect plug X2 on connecting cable 8a with power unit TPS 300/DCU 300 (please see Section 10. Accessories) on connection X2.
- ➔ Using screws and toothlock 8c (two pieces, included with the cable consignment) secure plug X2 to power unit 105.¹⁾

¹⁾ Only with cable PM 051 843 -T



Once operations voltage has been supplied, the TC 600 performs a self test on the supply voltage. The supply voltage for the turbopump is 72 VDC ± 5% in accordance with EN 60 742.

If the turbopump is to be operated with the Display and Operating Unit DCU 001/DCU 300 or HPU 001, the remote plug 8d on the TC 600 should be disconnected and then proceed in accordance with the respective operating instructions.



Voltage may only be supplied with the Pfeiffer Vacuum power units (Accessory). The use of other power units requires the prior agreement of the manufacturer and equalization with the valid specification (power unit specifications available on request).

Please refer to Operating Instructions PM 0521 BN for details on Power Unit TPS.



The mains connection must be freely accessible at all times.

Connecting the TC 600 with Power Unit TPS 300/DCU 300

- X1 Mains connection
- X2 Connection, power unit
- X4 Connection, TC 600
- S1 ON/OFF switch
- 8 Electronic Drive Unit TC 600

- 8a Connecting cable TC 600 - TPS/DCU
- 8b Screw
- 8c Screw with tooth lock
- 8d Remote plug
- 105 Power Unit TPS 300

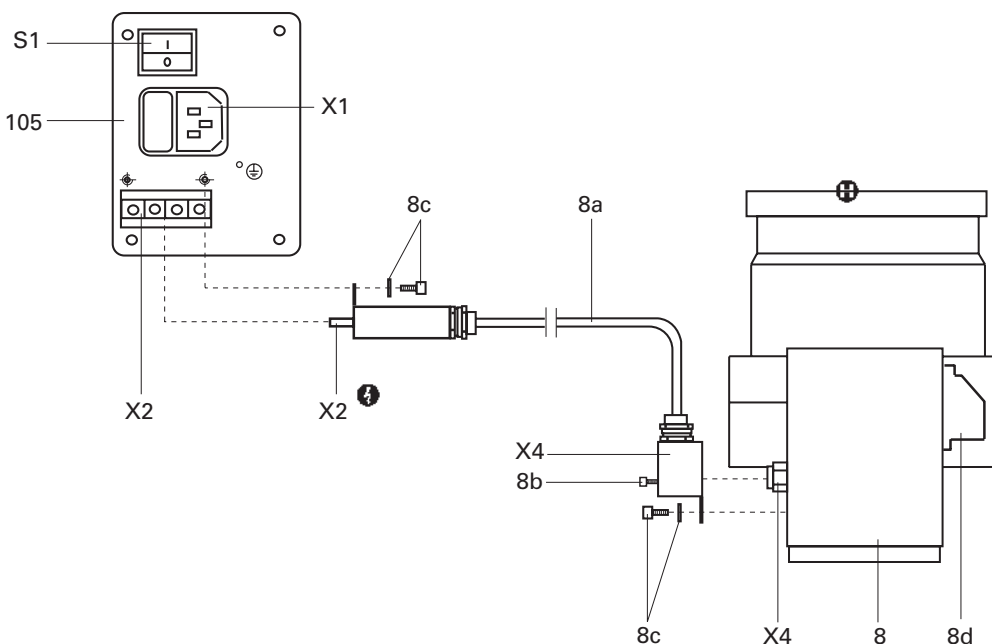

3.11. Connecting The Remote Control Unit

Remote control options for various functions are provided with the connection "REMOTE" on the TC 600 via the 15-pole D-Sub-Connector. Shielded cable must be used. Shielding is on the plug side of the TC 600 connected to the TC casing.

The inputs 2-6 are activated by connecting them to the + 24 V on pin 1 (active high) (please see Section 3.13. Connection Diagram).

Pin occupancy and remote plug functions
(please see following table)

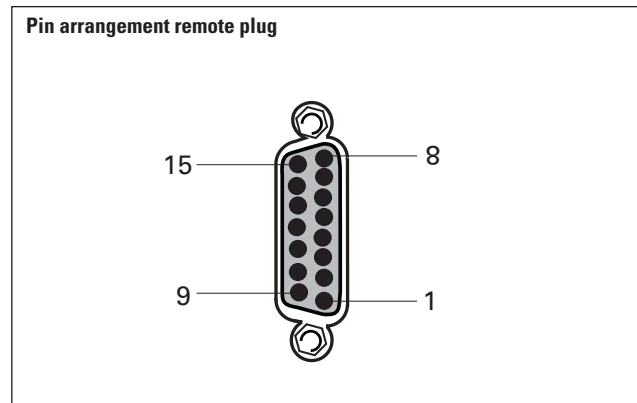

When connecting supply voltage, the turbopump is started.

On delivery:
Pin 1, Pin 2, Pin 3 and Pin 4 are bridged in the mating plug.

Pin occupancy and remote plug functions		
Pin nr.	Input open (low)	Input closed (high) on + 24V (pin 1)
1	+24 V	
2	venting blocked (see Section 3.5.)	venting released (see Section 3.5.)
3	motor, turbopump off	motor, turbopump on: the turbopump is driven, current flows through the motor coils
4	pumping station off	pumping station on: the turbopump is driven, backing pump is started via the relay box
5	heating off optional: Sealing gas valve off ¹⁾	heating on: the heating is switched on once the rotation speed switchpoint is attained and off when the rotation speed switchpoint is unattained optional: Sealing gas valve on ¹⁾
5		reset: by supplying a pulse (T < 2s) with an amplitude of 24V a malfunction acknowledgement can be processed
6	standby off	standby on: pump is accelerated to 66% of its nominal rotation speed
7	rotation speed setting mode off	the rotation speed can be changed by feeding a PWM signal to this pin or via Serial Interface RS 485 (see Section 4.9. "Rotation Speed Setting Mode")
8	Output (low) rotation speed switchpoint not attained	Output (high) rotation speed switchpoint attained; output can be loaded with 24 V/50 mA
9	Output (low) Collective malfunction message	Output (high) malfunction-free operations; output can be loaded with 24 V/50 mA
10	Mass (ground)	—————
11	Contact Output 1: Switchpoint attained	contact ²⁾ between pin 11 and pin 12 closed if the turbopump is above the switchpoint
12	Contact Output 1: Switchpoint attained	
13	Contact Output 2: Collective malfunction message	contact ²⁾ between pin 13 and pin 14 open in the event of a collective malfunction
14	Contact Output 2: Collective malfunction message	
15	Analog output	rotation speed proportional output voltage 0 - 10 VDC = 0 - 100 % * f _{end} /load R ≥ 10 kΩ

1) The option must be set via the Serial Interface RS 485 (please see Operating Instructions PM 0547 BN, Pumping Operations with DCU.

2) The following technical data is applicable for the contacts: U_{max} = 50 VDC
I_{max} = 1 A

3.12. Connecting The Serial Interface RS 485

An external operating component (DCU 001, DCU 300 or HPU 001) or an external computer can be connected via the connection "RS 485" on the TC 600 with the use of a shielded 8 pole modular connecting cable contained with the delivery.

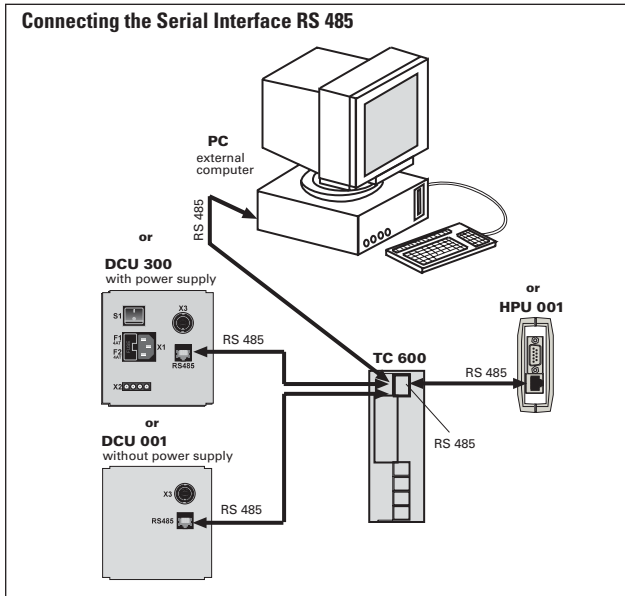

The serial interface is galvanically and safely separated from the maximum supply voltage from the TC 600.

Connection

Description	Value
Serial Interface Type:	RS 485
Baudrate:	9600 baud
data word lengths:	8 bit
Parity:	no (no parity)
Startbits:	1
Stopbits:	1..2

The electrical connections are internally optically decoupled at TC 600.

Pin	Arrangement
1	not connected
2	+24 V output (≤ 210 mA loading capacity)
3	not connected
4	not connected
5	RS 485: D+ (DO / RI)
6	Gnd
7	RS 485: D- (\overline{DO} / \overline{RI})
8	not connected

RS 485



1 ... 8

(View from the plug side of the TC 600)



It is possible to connect an RS 232 (e.g. PC) via a level converter (please see Section 10. Accessories).

Connecting The RS 485

Connecting to a fixed bus system:

- ➔ Connect all units with D+ (pin 5 / RS 485) and D- (pin 7 / RS 485) to the bus.
- ➔ The bus must be completed at both ends.

The connections should be made in accordance with the specification of the Serial Interface RS 485.

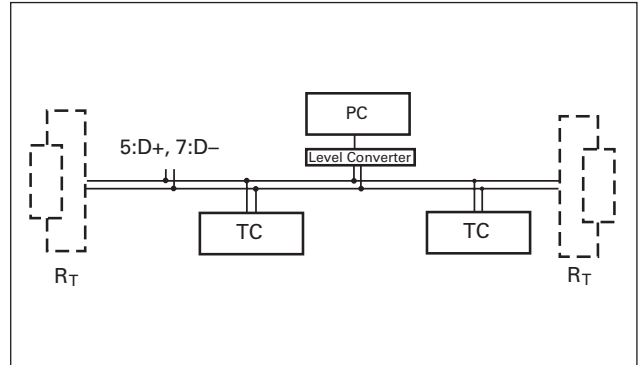

All units connected to the bus must have differing serial interface addresses (parameter 797).

The group address of the TC 600 is 960.



Only safety low voltages (SELV) may be connected to Serial Interface RS 485.

All switched on remote functions have priority over the serial interface functions.



Please refer to the separate Operating Instructions PM 0488 BN for more detailed information on operations via Serial Interface RS 485 and its electronic data.

Profibus DP Gateway TIC 250 is available (accessory) for connecting an Electronic Drive Unit TC 600 to a Profibus DP. Please refer to the respective Operating Instructions PM 0599 BN for detailed information on the operation of the TIC 250.

3.13. Connections Diagram

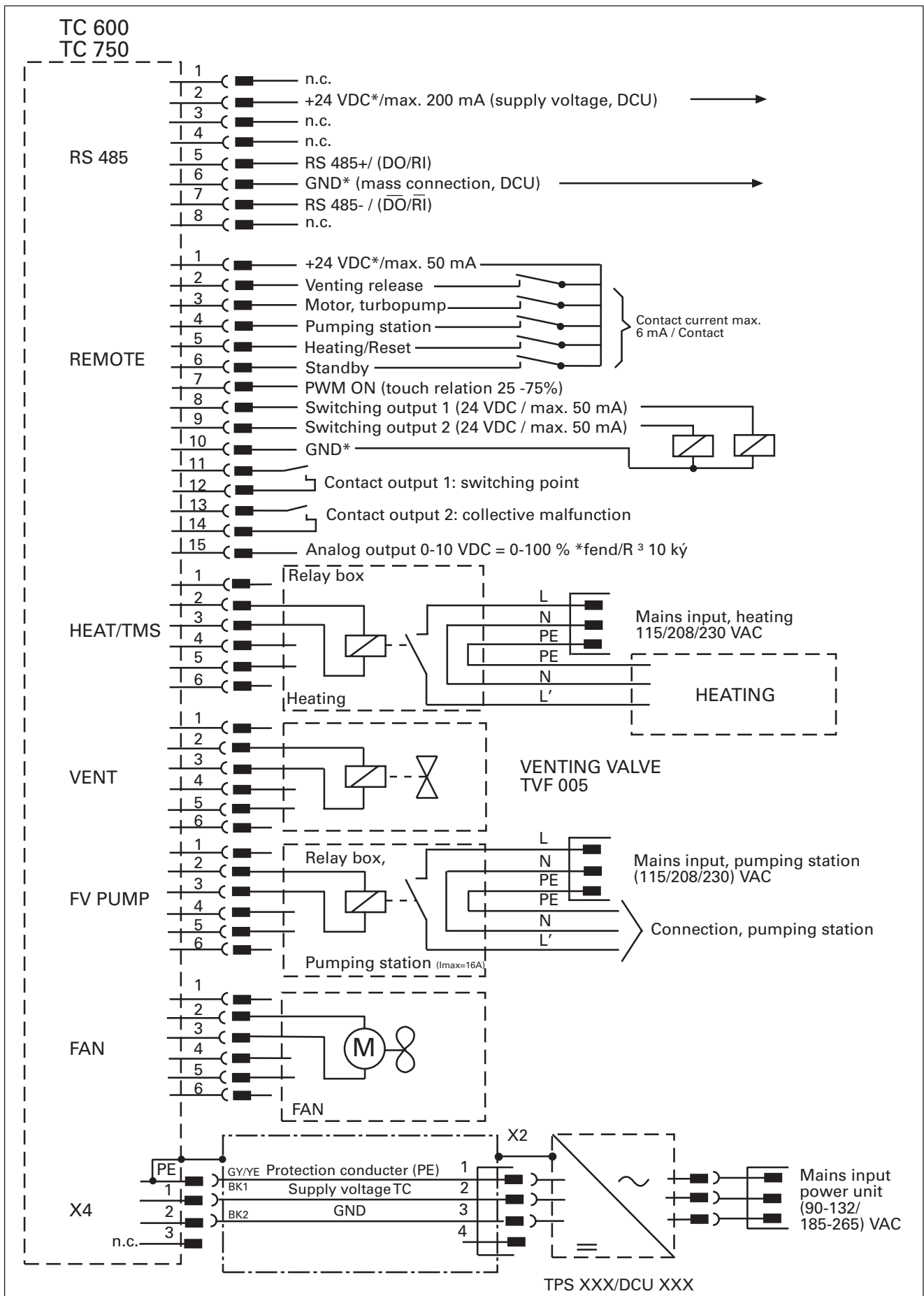

4. Operations

4.1. Filling In The Lubricant



Pumps **must** be filled with lubricant "F3" before being operated.

The turbopumps must **not** be transported when filled with lubricant.

If possible fill in the lubricant in the fitting position of the pump.

Pumps are designed to operate with Lubricant "F3" contained with the delivery 35 ml (see type plate).



If "F3" is heated above 300 °C, toxic vapours which can harm the airways are given off. Do not allow "F3" to come into contact with tobacco products (danger of poisoning when ignited). The precautions necessary in the handling of chemicals must be observed.

Filling in the lubricant

- ➔ Unscrew lubricant filler screw 71 and, using the syringe provided, inject 35 ml of lubricant.
- ➔ Screw back in lubricant filler screw 71 with the O-ring 75.

If the pump is to be operated, the sight glass must be at least one third full of lubricant.

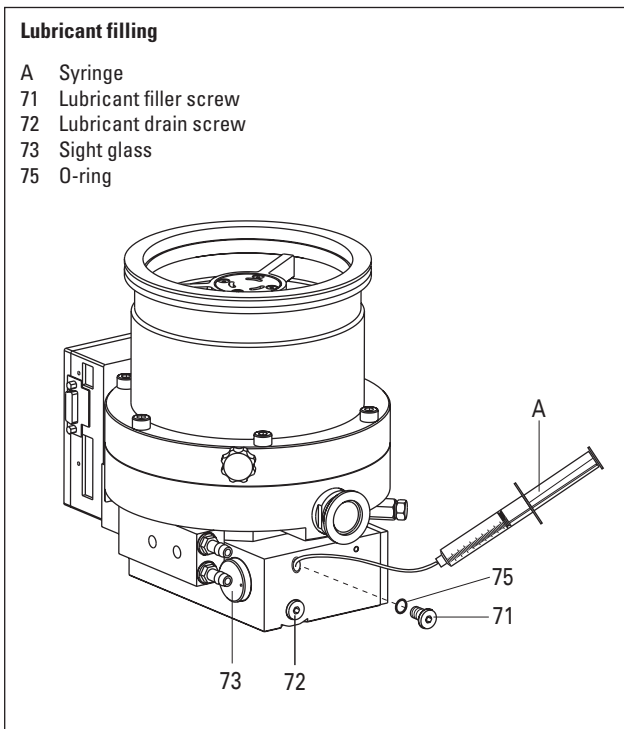

If the pump is operated in an installation position at an angle $> 0^\circ$ the lubricant is to be filled in via the lubricant filler screw on the underside of turbopump (please see next figure).

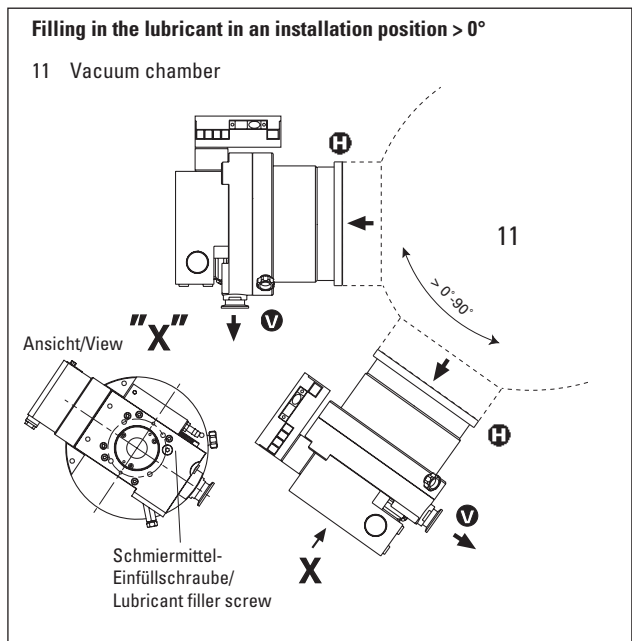

4.2. Before Switching ON



Turbopump rotors rotate at high speed. When the high vacuum flange is open there is a danger of injury and of damage to the pump caused by objects falling into the pump.

Therefore never operate the pump with open high vacuum flange.



Take care when pumping hazardous gases and observe the safety precautions of the gas manufacturer.

- ➔ With sealing gas: Open the sealing gas supply.
- ➔ Open cooling water supply and check flow.
- ➔ Plug connecting cable 8a (Section 10. Accessories) into the TC 600 and connect with Power Unit TPS on X2 (please see Section 3.9.).

Please note:

The following pre-settings have been programmed:

- Start-up time 8 min
- Rotation speed switchpoint 80%
- Automatic venting 50%

These settings can only be altered via Serial Interface RS 485 (DCU, HPU or PC); please refer to the respective operating instructions.

4.3. Switching ON

- ➔ Switch on the turbopump with switch S1 on the power unit.
- Once the self test has been successfully completed on the TC 600 (duration approximately 15 seconds), both the turbopump and the backing pump (if connected) begin operating.

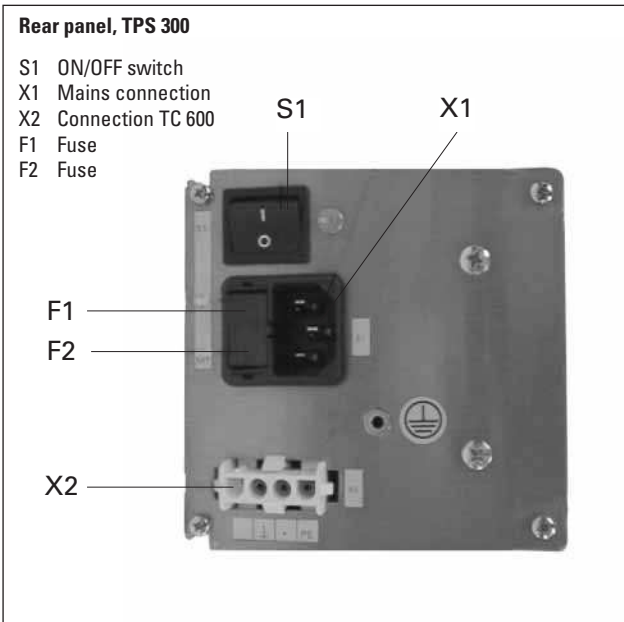

When switching on for the first time or after a lubrication change, the flow of lubricant can be interrupted as a result of the formation of gas bubbles. In such cases, as in other malfunctions, the electronic drive unit switches off the turbopump.

- ➔ Switch off the turbopump starting switch S1 on the power unit TPS 300 and then on again.

4.4. Gas Type Dependent Operations

Where high level gas loads and rotation speeds are involved, the resulting friction subjects the rotor to the effect of great heat. To avoid over-heating, a power rotation speed characteristic line is implemented in the TC 600; this ensures that where maximum gas loads are involved, the pump will operate at any rotation speed without the danger of damage arising. The maximum power is dependent on the type of gas. Two characteristic lines are available for any type of gas in order to fully exploit the power potential of the pump:

- "Gas-Mode 0" for gases with molecular mass ≥ 40 as, for example, Argon;
- "Gas-Mode 1" for all lighter gases.

Works setting: Gas mode 0

- ➔ Set the applicable gas mode on the TC 600 via the DCU or HPU (please refer to the respective operating instructions).



Pumping gases with molecular mass ≥ 40 with the incorrect gas mode can cause damage to the pump. When pumping noble gases heavier than Argon it can come to the destruction of the pump. Please contact the manufacturer before using such gases.

For the vertex of the power characteristic line please refer to Section 9. Technical Data.

Maximum power is applied when the pump starts in order to limit the time required. Once the set rotation speed is attained, switching to the selected power characteristic line is automatic.

If the gas dependent maximum power is exceeded, the rotation speed is reduced until equilibrium between the permissible power and gas friction is attained.

The power limitation serves to protect the pump against thermal over-loading. In order to avoid rotation speed fluctuations it is recommended to set, in rotation speed setting mode, the equilibrium frequency or a somewhat lower frequency.



There can be types of pump whereby there is no differentiation between the two "gas modes" settings.

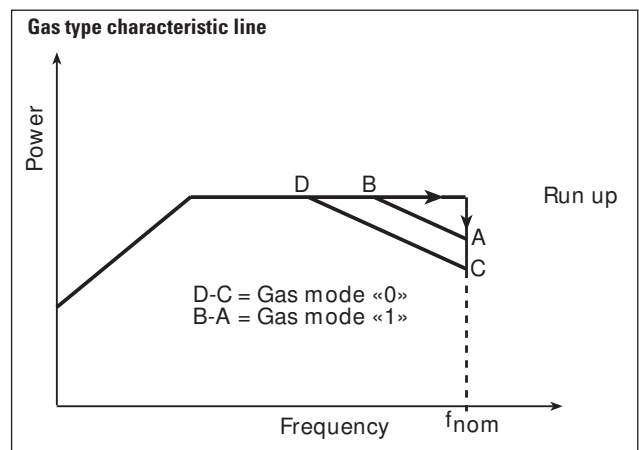

4.5. Circulatory Lubrication

The ball bearing on the fore-vacuum side is supplied with lubricant via the lubricating pump.

The circulation of the lubricant is monitored via a switching contact. If there is insufficient lubricant, the electronic drive unit switches off the turbopump. Monitoring is active only from 60% of the final rotation speed.

If, at a rotation speed of > 60% of the final rotation speed (for example through the degassification of the lubricant), the contact opens for ≥ 2 minutes, the electronic drive unit assumes a lubricant deficiency and switches off the turbopump.

- ➔ Check the filling level of the lubricant.
- ➔ Switch off the turbopump starting switch S1 on the power unit and then on again.
- ➔ Check lubricant pump function.

4.6. Switching OFF And Venting

To avoid contamination occurring when switching off, the pump should be vented before shut-down.

- ➔ Switch off both turbopump and backing pump on the power unit at the same time with switch S1.
Where corrosive gas processes are involved, the sealing gas supply should be shut off after approximately 10 minutes and both turbo pump and backing pump switched off with switch S1.

➔ Venting

There are three possibilities to vent turbopump:

- **Manual venting** with the use of the venting screw (status on delivery).
- **Venting with the venting valve TVF 005** (Accessory)
The venting modes are selectable via the remote control (please see Section 4.9.), via the DCU or HPU (please refer to the relevant operating instructions).
- **Venting in two stages** when the vacuum chamber should be vented as quickly as possible.

First stage: venting with a pressure increase rate of 15 mbar/s for 20 seconds.

Second stage: venting with an optionally large venting valve.

The valve cross-section for a venting rate of 15 mbar/s must be compatible with the size of the vacuum chamber. Where small vacuum chambers are involved, the Pfeiffer Vacuum Venting Valve TVF 005 can be used for first stage venting.

- ➔ Shut off water supply.

4.7. Shutting Down For Longer Periods



Vacuum pumps are sometimes used to pump aggressive or hazardous gases. There is a danger of personal injury resulting from coming into contact with process gases. Before removing a turbopump from the system, first:

- Vent the turbopump with a neutral gas or dry air.
- Ensure that there is no residual process gas in the system nor in the feeder lines.

If the turbopump is to be shut down for more than a year:

- ➔ Remove turbopump from the system.
- ➔ Change the lubricant (see Section 7.1.).
- ➔ Close the high vacuum flange and evacuate the turbopump via the fore-vacuum flange.
- ➔ Vent turbopump via the venting connection with nitrogen or dry air.
- ➔ Close fore-vacuum and venting connection by blank flanging.
- ➔ Place the pump vertically on its rubber feet.
- ➔ The pump must be stored in buildings within a temperature range of -25 °C to +55 °C.
- ➔ In rooms with moist or aggressive atmospheres, the turbopump must be air-sealed in a plastic bag together with a bag of desiccant, e.g. silicagel.



If the pump has been shut down for 3 years a bearing change must be carried out (please get in touch with Pfeiffer Vacuum Service).

4.8. Operations With The DCU 001, DCU 300 or HPU 001

Operations with the DCU 001, DCU 300 or HPU 001 should be carried out in accordance with the relevant Operating Instructions:

- PM 0477 BN (DCU description)
- PM 0547 BN (Operating the pump with the DCU)
- PT 0101 BN (Display and Operating Unit HPU 001).



Operations with the DCU 001, DCU 300 and HPU 001, the remote plug 8d on the TC 600 (please see Section 2.1.) should be disconnected.

4.9. Operations With The Remote Control Unit

Remote control operations can be performed via the connection with the designation "REMOTE" on the TC 750. The connection is via a 15 pole D-Sub connector.

Pin arrangement and remote plug functions please see table under Section 3.11..

Inputs 2-6 are activated if they are connected with the +24 V on pin 1 (active high).



On delivery there is a bridge between Pin 1, Pin 2, Pin 3 and Pin 4 on the TC 750 mating plug. When operations voltage is supplied and a successfully completed.

TC 750 self-test the turbopump and any connected backing pump will be started.

Venting Release (Optional)

Automatic venting:

Venting frequency (correspond to 50% of the final rotationspeed)	Switch off the pumping station	Mains power failure ¹⁾
< 357 Hz	venting valve opens for 3600 s (1 h) (works setting)	venting valve opens and closes on attainment of approximately 15% of the final rotation speed

1) When mains power is restored the venting procedure is interrupted

Venting OFF:

Venting does not take place.

Other venting modes:

Other venting modes can be selected via the DCU or HPU.

Motor, Turbopump

When the pumping station is switched on and once the self test has been successfully completed (duration see Section 4.3.), the turbopump is set in operation. During operations, the turbopump can be switched on and off while the pumping station is switched on. Thereby the turbopump will not be vented.

Pumping Station

Any connected pumping station components are started up (e.g. backing pump, venting valve, air cooling) and with simultaneous activation of the input "motor, turbopump" the turbopump is set in operation once the self test has been successfully completed (duration see Section 4.3.).

Heating/Reset

Heating (optional)

Once the rotation speed switchpoint is attained the heating unit is switched on; when the rotation speed switchpoint is fallen below the heating unit is switched off.

Reset

The heating input has two functions (please see Section 3.11., point 5 "Reset").

Standby

The pump can be operated optionally at 66% of its nominal rotation speed (standby ON) or at its nominal rotation speed (standby OFF).

Rotation Speed Setting Mode Via Input PWM

The supply of pulse width modulated signals (PWM) with a ground frequency of 100 Hz $\pm 20\%$ with an amplitude of maximum 24 V and a touch ratio of 25-75% enables the rotation speed to be set in the range from 20-100% of the nominal rotation speed.

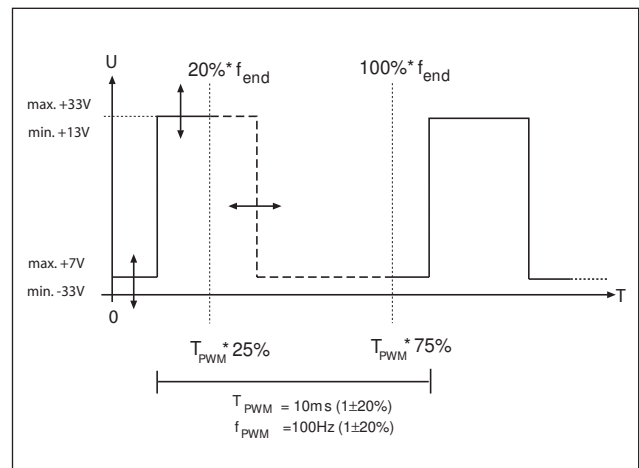

If no signal is present the pump accelerates up to its final rotation speed.

A PWM adapter box for rotation speed setting operations for the turbopump is available as an option (please see Section 10, Accessories).

Switching Outputs

Switching outputs 1 and 2 can be loaded with a maximum 24 V / 50 mA per output. The following functions are assigned to the switching outputs:

Switching output 1: Active high when the rotation speed switchpoint is attained. The switchpoint for the turbopump is set at 80% of the nominal rotation speed. It can be used, for example, for a message "pump ready to operate".

Switching output 2: Active low with a malfunction - collective malfunction message.



The connection of a relay is made between pin 10 (mass) and the respective switching output pin 8 or pin 9 (see Section 3.13. Connections Diagram).

5. Monitoring Operations

5.1. Operations Display Via LED

Certain operations modes of the turbopump and the TC 600 can be ascertained via the two integrated LEDs located on the front panel of the TC 600.

The following operations modes are displayed:

LED		Cause
 green	 red	
glows	–	<ul style="list-style-type: none"> – power unit OK – Function "pumping station ON" carried out
flashes (1/12 s active)		<ul style="list-style-type: none"> – Power unit OK – Pumping station OFF
blinks (1/2 s active)		<ul style="list-style-type: none"> – Mains power supply failure
	glows	<ul style="list-style-type: none"> – Collective malfunction (for example, start-up time error, excess temperature, turbopump or TC 600, lubricant deficiency) – Switching output 2 active (low)
	blinks (1/2 s active)	<ul style="list-style-type: none"> – Warning (for example, earth leakage fault in the voltage supply, mains power supply failure)

5.2. Turbopump Temperature Monitoring

Where impermissible motor temperatures are involved or the temperature of the casing is too high, the motor current is reduced.

This can lead to dipping below the set rotation speed switchpoint and results in the turbomolecular pump being switched off.

LED on the TC 600 glows red: Collective malfunction.



Differentiated malfunction and warning signals are only possible with the use of the DCU or HPU.

6. What To Do In Case Of Breakdowns?

Problem	Possible Causes	Remedy
Pump doesn't start; None of the integrated LEDs glow on the TC 600	<ul style="list-style-type: none"> • Power supply interrupted • Incorrect operations voltage supplied • Pins 1-3 and 1- 4 on the remote-plug not connected • No supply of operations voltage • Defect TC 600 • Reduction in the voltage in the cable 	<ul style="list-style-type: none"> • Check fuse in the power unit • Check plug contacts on the power unit • Check power unit feeder line • Check voltage on the power pack unit (72 VDC) at connection X2 • Supply correct operations voltage • Connect pins 1-3 and 1- 4 on the remote plug • Check plug contacts on the power unit • Replace TC 600 (please see Sec. 7.3.) • Use suitable cable
Pump doesn't attain nominal rotation speed within the set start-up time; Pump cuts out during operations	<ul style="list-style-type: none"> • Fore-vacuum pressure too high • Leak or too high levels of gas load • Rotor sluggish caused by defective bearing • TC start-up time too short • Thermal overloading caused by: <ul style="list-style-type: none"> – Insufficient water flow – Insufficient air supply – Fore-vacuum pressure too high – Ambient temperature too high • Lubricant or lubricating pump dirty • Lubricant deficiency 	<ul style="list-style-type: none"> • Check backing pump function • Check seals • Seek leak and repair • Supply of process gas too high; reduce • Check bearing (noises?): Request Pfeiffer Vacuum Service to replace • Set longer start-up time with the DCU/HPU or PC • Ensure free flow • Ensure adequate air supply • Reduce fore-vacuum pressure • Reduce ambient temperature • Carry out lubricant change as per Section 7.1. or clean the lubricating pump as per Section 7.2. • Check lubricant and replace as necessary
Pump doesn't attain final pressure	<ul style="list-style-type: none"> • Pump dirty • Leak in vacuum chamber, lines or pump 	<ul style="list-style-type: none"> • Bake out pump • If seriously contaminated: Request Pfeiffer Vacuum Service to clean • Seek leak starting with vacuum chamber • Repair leak
Unusual operating noises	<ul style="list-style-type: none"> • Bearing damaged • Rotor damaged • Splinter shield (if fitted) not seated firmly 	<ul style="list-style-type: none"> • Inform Pfeiffer Vacuum Service of need for repair • Inform Pfeiffer Vacuum Service of need for repair • Check seat of splinter shield
Red LED on the TC 600 glows	<ul style="list-style-type: none"> • Collective malfunction 	<ul style="list-style-type: none"> • Reset via mains OFF/ON or remote pin 5 • Different malfunction display with a DCU or HPU¹⁾ possible
Red LED on the TC 600 blinks	<ul style="list-style-type: none"> • Warning from: <ul style="list-style-type: none"> – Mains power failure – Supply voltage short circuit to earth • Wrong setting for nominal rotation speed (Parameter 777) 	<ul style="list-style-type: none"> • Different warning display with a DCU or HPU¹⁾ is possible • Check power pack voltage • Check the power pack mains connection • Check the power unit voltage for short circuit to earth • Enter 717 Hz for parameter 777 (see operating instruction PM 0547 BN "Pumping Operations With DCU"). If there is no DCU/HPU available contact Pfeiffer Vacuum Service.

1) Without a DCU inform Pfeiffer Vacuum Service to check the cause of trouble.

7. Maintenance/Replacement



No liability for personal injury nor material damage will be accepted for damages and operational interruptions which have been caused by improper maintenance; in addition, all guarantees become invalid.

You can replace the lubricant and the Electronic Drive Unit TC 600 yourself (see Section 7.1. and 7.3.)

Please contact your local Pfeiffer Vacuum Service for all other maintenance and service work.



Ensure no mechanical forces act on the Electronic Drive Unit TC 600.

7.1. Replacing The Lubricant

The lubricant should be replaced at least once a year. Where extreme operating conditions or unclean processes are involved, the replacement interval should be checked with your Pfeiffer Vacuum Service Center.



Drain of and fill in the lubricant in the fitting position if possible. If it is absolutely necessary to dismantle the pump to change the lubricant, this may only be carried out in the position shown in Section 3.2. Otherwise the lubricant could contaminate the pump.



Lubricant drain screw 72 may only be opened if the turbopump has been vented to atmospheric pressure.

- ➔ Switch off the turbopump, vent to atmospheric pressure (see Section 4.5.) and allow to cool as necessary.
- ➔ Unscrew lubricant drain screw 72 and drain lubricant into a suitable container.



Lubricants can contain toxic substances from the medium pumped. Lubricant must be disposed of in accordance with the respective regulations. Safety instructions data sheet for the lubricant on request.

- ➔ Screw back in lubricant drain screw 72 with the O-ring 75.
- ➔ Unscrew lubricant filler screw 71. Using the syringe provided inject maximum 35 ml of lubricant as per the type plate (please see Section 4.1. for the lubricant level).
- ➔ Screw in lubricant filler screw 71 with the O-ring 75.

Replacing the lubricant

- 71 Lubricant filler screw
- 72 Lubricant drain screw
- 73 Sight glass
- 75 O-ring

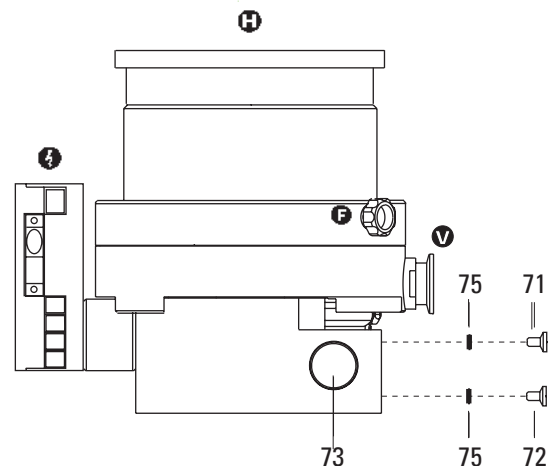

If the pump is operated in an installation position in an angle $> 0^\circ$ the lubricant is to be filled in via the lubricant filler screw at the underside of turbopump (please see Section 4.1.).

7.2. Cleaning The Lubricating Pump

If, following a malfunction, the pump does not accelerate to its operational rotation speed on account of insufficient lubricant, the lubricating pump must be cleaned.

For cleaning the lubricant pump please contact your local Pfeiffer Vacuum Service Center.

7.3. Replacing The Electronic Drive Unit TC 600



The turbopump and the TC 600 must only be disconnected from each other when the turbopump is completely at rest and the TC 600 has been disconnected from the power supply.

- ➔ Switch off the turbopump, vent to atmospheric pressure (see Section 4.6.) and allow to cool as necessary.
- ➔ If necessary, remove the turbopump from the system.
Unsrew screws 8c (2 pieces) from the Electronic Drive Unit TC 600 and remove the TC 600 from the turbopump.

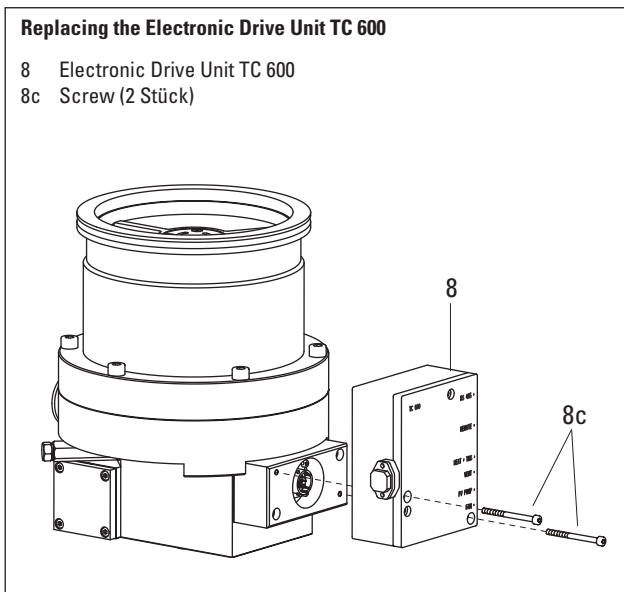

- ➔ Install the new Electronic Drive Unit TC 600 back onto the turbopump and connect again.



Please take into account that after replacement the standard operating parameters are always pre-set.
If your application requires different parameters, please modify accordingly.

8. Service

Do make use of our service facilities

In the event that repairs are necessary a number of options are available to you to ensure any system down time is kept to a minimum:

- Have the pump repaired on the spot by our Pfeiffer Vacuum Service Engineers;
- Return the pump to the manufacturer for repairs;
- Replace the pump.

Local Pfeiffer Vacuum representatives can provide full details.



Please take into account that where Pfeiffer Vacuum Service replacement service is involved the standard operating parameters are always pre-set.

If your application requires different parameters, please modify accordingly.



The turbopump and the Electronic Drive Unit TC 600 form a single unit and must therefore be returned complete for repair purposes. Before returning the unit it should be ensured that the power unit is not the cause of the malfunction (please see Section 5. for checking the power unit).

Before returning:

- ➔ Dismantle all accessories.
- ➔ If the unit is free of harmful substances please attach a clearly visible notice "Free of harmful substances" (both on the unit and also on the delivery note and any accompanying letters).

"Harmful substances" are substances and preparations as defined in the current, local, dangerous substances regulations; in the U.S.A. as "materials in accordance with the Code of Federal Regulations (CFR) 49 Part 173.240 Definition and Preparation". We will carry out the decontamination and invoice this work to you if you have not attached this note. This also applies where the operator does not have the facilities to carry out the decontamination work.

Fill out the declaration of contamination

- ➔ In every case the "Declaration of Contamination" must be completed diligently and truthfully.
- ➔ A copy of the completed declaration must accompany the unit; any additional copies must be sent to your local Pfeiffer Vacuum Service Center.

Please get in touch with your local Pfeiffer Vacuum representatives if there are any questions regarding contamination.



Decontaminate units before returning or possible disposal. Do not return any units which are microbiologically, explosively or radioactively contaminated.

Returning contaminated units

If contaminated have to be returned for maintenance/repair, the following instructions concerning shipping must be followed:

- ➔ Neutralise the pump by flushing with nitrogen or dry air.
- ➔ Seal all openings to the air.
- ➔ Seal pump or unit in suitable protective foil.
- ➔ Return equipment only in suitable, rugged shipping containers and by complying with the currently valid shipping regulations.

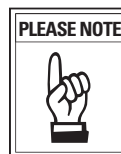

Repair orders are carried out according to our general conditions of sale and supply.

If repairs are necessary, please send the pump together with a short damage description to your nearest Pfeiffer Vacuum Service Center.

9. Technical Data

Feature	Unit	TPH 521 P C		TPH 521 P C	
Connection nominal diameter:: Inlet		DN 100 ISO-K DN 100 ISO-F	DN 160 ISO-K DN 160 ISO-F	DN 100 CF-F	DN 160 CF-F
Outlet		DN 25 ISO-KF/G 1/4"		DN 25 ISO-KF/G 1/4"	
Venting connection		G 1/8"		G 1/8"	
Nominal rotation speed	Hz (1/min)	717 (43 000)		717 (43 000)	
Standby rotation speed	Hz (1/min)	477 (28 600)		477 (28 600)	
Start-up time (up to 90% of the nominal rotation speed)	min	3.5		3.5	
fore-vacuum pressure ≤ 0.1 mbar)					
Maximum noise level ¹⁾	dB (A)	50		50	
Final pressure, backing pump	mbar	$< 10^{-2}$		$< 10^{-2}$	
Integral leak rate (He) ²⁾	mbar l/s	$< 1 \cdot 10^{-7}$		$< 1 \cdot 10^{-7}$	
Maximum permissible rotor temperature	°C	120		120	
Permissible heat radiaten power	W	14		14	
Volum flow rate for:					
Nitrogen N ₂	l/s	260	430	260	430
Helium He	l/s	296	380	266	380
Hydrogen H ₂	l/s	220	300	220	380
Argon Ar	l/s	245	430	245	430
Tetrafluoromethane CF ₄	l/s	200	360	200	360
Compression ratio for:					
N ₂		$> 10^7$		$> 10^7$	
He		$4.8 \cdot 10^3$		$4.8 \cdot 10^3$	
H ₂		$3 \cdot 10^2$		$3 \cdot 10^2$	
Ar		$> 10^7$		$> 10^7$	
CF ₄		$> 10^7$		$> 10^7$	
Maximum fore-vacuum pressure					
N ₂	mbar	1.0		1.0	
He	mbar	0.8		0.8	
H ₂	mbar	0.4		0.4	
Ar	mbar	1.3		1.3	
CF ₄	mbar	1.4		1.4	
Maximum gas throughput ³⁾ at final rotation speed					
N ₂	mbar l/s	7.6		7.6	
He	mbar l/s	14.5		14.5	
H ₂	mbar l/s	50.0		50.0	
Ar	mbar l/s	3.8		3.8	
CF ₄	mbar l/s	4.0		4.0	
Maximum gas throughput at intake pressure of 0.1 mbar ⁴⁾					
N ₂	mbar l/s	6.0		6.0	
He	mbar l/s	4.0		4.0	
H ₂	mbar l/s	3.0		3.0	
Ar	mbar l/s	7.0		7.0	
CF ₄	mbar l/s	8.0		8.0	
Vertex power characteristics line ⁵⁾					
A	W / Hz	260/715		260/715	
B	W / Hz	260/715		260/715	
C	W / Hz	220/715		220/715	
D	W / Hz	260/605		260/605	
Final pressure ⁶⁾ with rotary vane vacuum pump	mbar	$< 1 \cdot 10^{-8}$		$< 5 \cdot 10^{-10}$	
Lubricant Type ⁷⁾		F3		F3	
Filling volume	ml	35		35	
Maximum cooling water consumption with water at 15 °C ⁸⁾	l/h	100		100	
Cooling water temperature	°C	5 - 25		5 - 25	
Power consumption, casing heating unit	W	100		100	
Weight	kg	16.5 (ISO-K)/ 17.5 (ISO-F)	16.0 (ISO-K)/ 18.0 (ISO-F)	17.5	17.0
Permissible magnetic field	mT	5.0		5.0	
Operating voltage	VDC	72 ±5%		72 ±5%	
Duration ⁸⁾ / max. current consumption	A	3.2/4.2		3.2/4.2	
Duration ⁸⁾ / max. power	W	230/300		230/300	
Protection class ⁹⁾		IP 30		IP 30	
Shipping and storage temperature	°C	-25 to +55		-25 to +55	
Relative humidity of air	%	5-85 non-condensing		5-85 non-condensing	

1) Distance from the pump 1 m

2) Measured at a helium concentration of 100 %, 10 s measurement time

3) Measured with the Rotary vane Vacuum Pump DUO 030 A.

4) Rotation speed of pump may drop below the nominal rotation speed.

5) For gas type characteristic lines please refer to section 4.4.

6) In accordance with DIN 28 428 the final pressure is that pressure which is attained in a measuring dome 48 hours after backing out.

7) Please see type plate.

8) With maximum gas throughput.

9) Protection class IP 54 is afforded for the Electronic Drive Unit TC 600 by retro-fitting a cover plate.

9.1. Dimensions Diagram

TPH/TPU 521 P C

DN 100 ISO-K/DN 100 CF-F

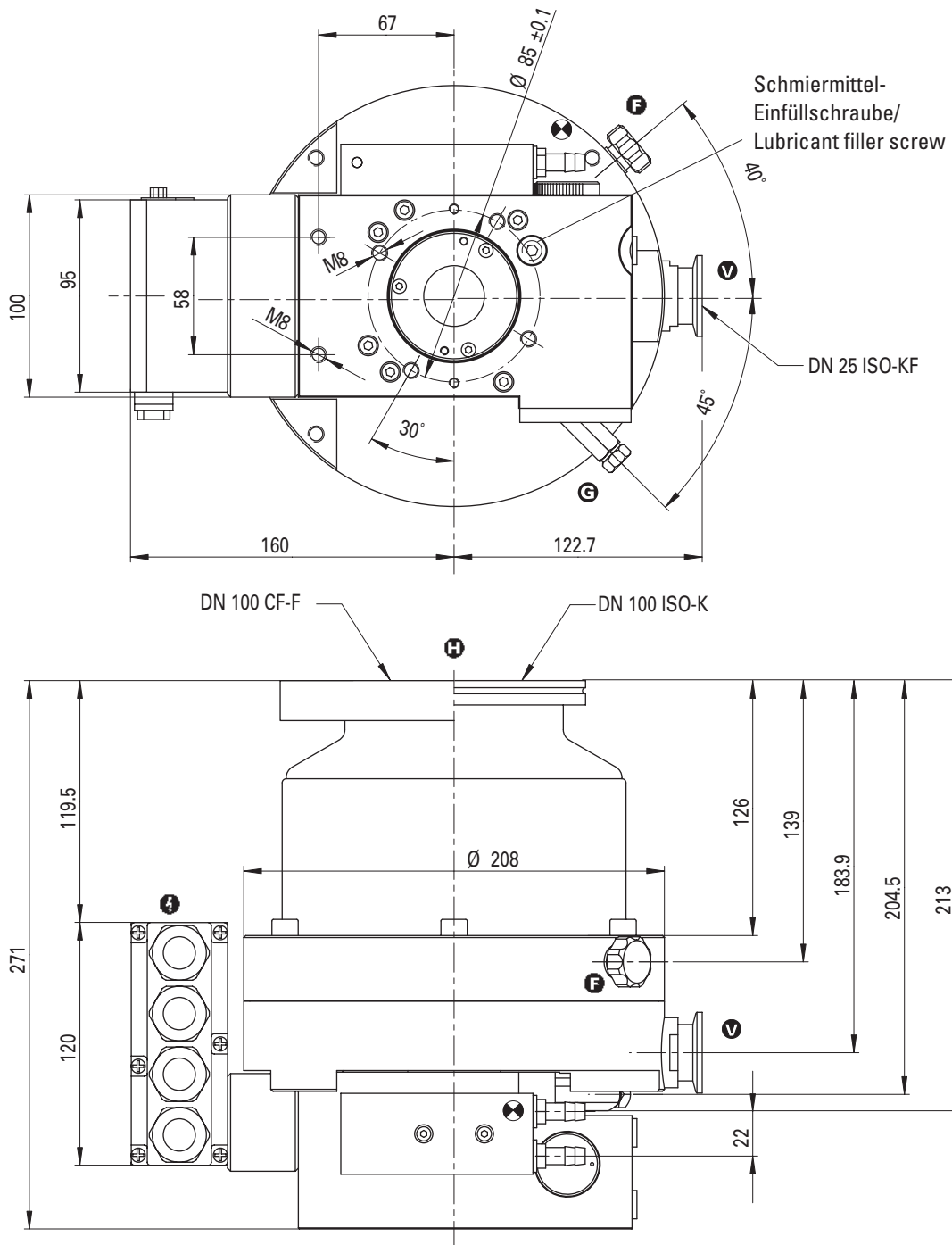

11. Spare Parts

Pos.	Description	Pieces	Size	Number	Comments	Order Quantity
Spare parts TPH/TPU 521 P C						
6	Blanking plug	4		P 4098 582 FA	see Sec. 7.3.	
8	Electronic Device Unit	1		PM C01 720		
8d	Remote plug	1		PM 051 793 -X		
17	USIT-ring	1		P 3529 133 -A		
71	Lubricant filler screw	1	A2-50, G1/8" A	N 3191 382 X		
72	Lubricant drain screw	1	A2-50, G1/8" A	N 3191 382 X		
73	Sight glass	1		PM 003 251		
75	O-ring	2	6 x 2.2	P 4070 088 PV		
76	O-ring	1	22 x 3	P 4070 384 PV		

When ordering accessories and spare parts please be sure to state the full part number. When ordering spare parts please state additionally the unit type and unit number (see type plate). Please use this list as an order form (by taking a copy).

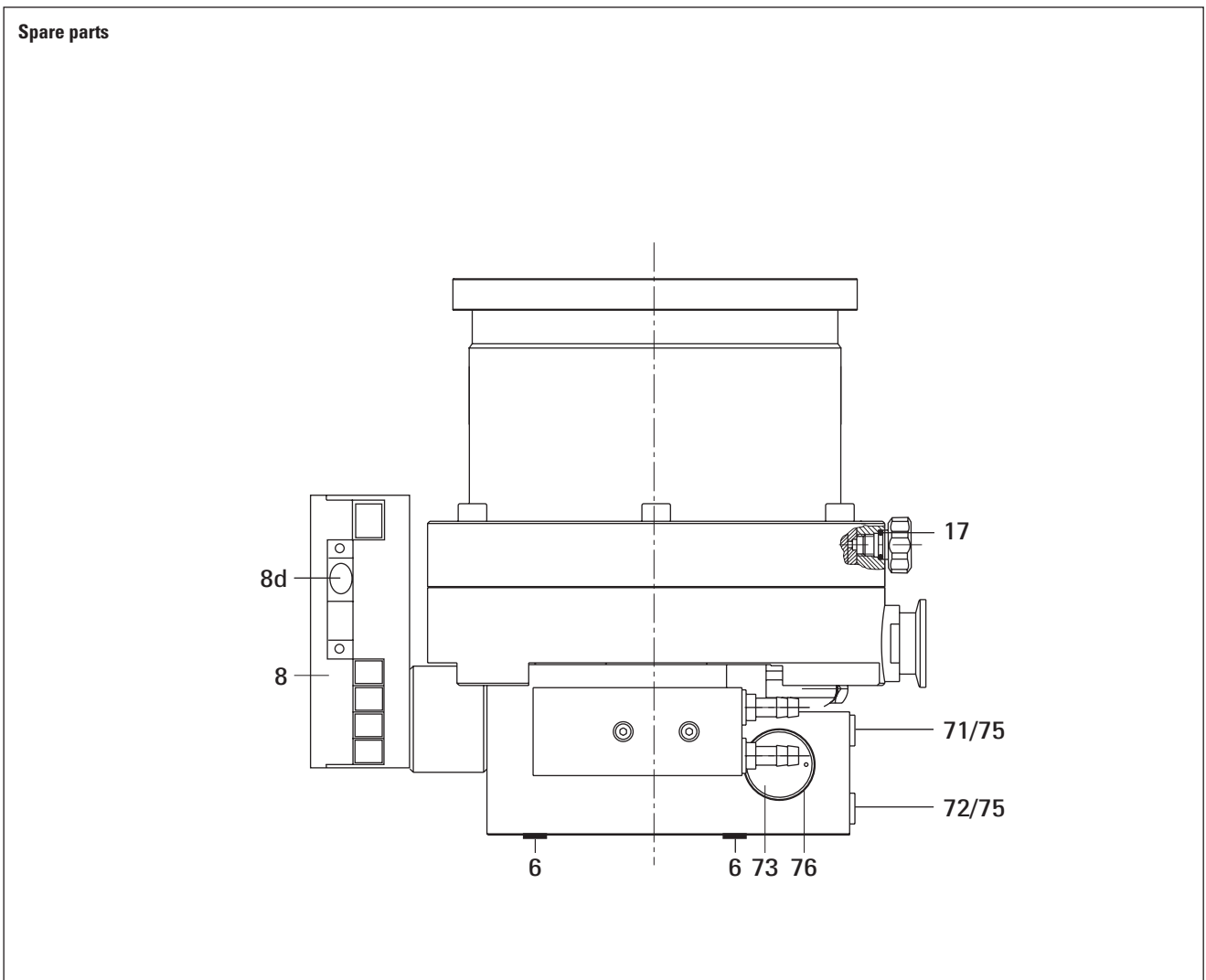

Declaration of Contamination of Vacuum Equipment and Components

The repair and/or service of vacuum components will only be carried out if a correctly completed declaration has been submitted. Non-completion will result in delay.

The manufacturer could refuse to accept any equipment without a declaration.

This declaration can only be completed and signed by authorised and qualified staff:

1. Description of component:

- Equipment type/model: _____
- Code No.: _____
- Serial No.: _____
- Invoice No.: _____
- Delivery Date: _____

2. Reason for return:

3. Equipment condition

- Has the equipment been used?
yes no
- What type of pump oil was used?

- Is the equipment free from potentially harmful substances?
yes (go to section 5)
no (go to section 4)

4. Process related contamination of equipment

- toxic yes no
- corrosive yes no
- microbiological hazard*) yes no
- explosive*) yes no
- radioactive*) yes no
- other harmful substances yes no

*) We will not accept delivery of any equipment that has been radioactively or microbiologically contaminated without written evidence of decontamination!

Please list all substances, gases and by-products which may have come into contact with the equipment:

Tradename Product name Manufacturer	Chemical name (or Symbol)	Danger class	Precautions associated with substance	Action if spillage or human contact
1.				
2.				
3.				
4.				
5.				

5. Legally Binding Declaration

I hereby declare that the information supplied on this form is complete and accurate. The despatch of equipment will be in accordance with the appropriate regulations covering Packaging, Transportation and Labelling of Dangerous Substances.

Name of Organisation: _____

Address: _____ Post code: _____

Tel.: _____

Fax: _____ Telex: _____

Name: _____

Job title: _____

Date: _____ Company stamp: _____

Legally binding signature: _____

Herstellererklärung Manufacturer's Declaration

im Sinne folgender EU-Richtlinien:
pursuant to the following EU directives:

- **Maschinen/Machinery 98/37/EWG (Anhang/Annex II B)**
- **Elektromagnetische Verträglichkeit/Electromagnetic Compatibility 89/336/EWG**
- **Niederspannung/Low Voltage 73/23/EWG**

Hiermit erklären wir, daß das unten aufgeführte Produkt zum Einbau in eine Maschine bestimmt ist und daß deren Inbetriebnahme so lange untersagt ist, bis festgestellt wurde, daß das Endprodukt den Bestimmungen der EU-Richtlinie 98/37/EWG entspricht.

Das unten aufgeführte Produkt entspricht den Anforderungen der EU-Richtlinien **Maschinen 98/37/EWG, Elektromagnetische Verträglichkeit 89/336/EWG** und **Niederspannung 73/23/EWG**.

We hereby certify that the product specified below is intended for installation in a machine which is forbidden to be put into operation until such time as it has been determined that the end product is in accordance with the provision of EU Directive 98/37/EEC.

*The product specified below is in correspondence to the EU directives **Machinery 98/37/EEC, Electromagnetic Compatibility 89/336/EEC** and **EU Low Voltage 73/23/EEC**.*

Produkt/Product:

TPH 521 P C / TPU 521 P C

Angewendete Richtlinien, harmonisierte Normen und angewendete nationale Normen:

Guidelines, harmonised standards, national standards in which have been applied:

**EN 12100-1, EN 12100-2, EN 294,
EN 1012-2, EN 61010a**

Unterschrift/Signature:



Pfeiffer Vacuum GmbH
Berliner Str. 43
35614 Asslar
Germany

(W. Dondorf)
Geschäftsführer
Managing Director

Vacuum is nothing, but everything to us!



Turbo Pumps



Rotary Vane Vacuum Pumps



Roots Pumps



Dry Vacuum Pumps



Leak Test Units



Valves



Flanges, Feedthroughs



Vacuum Measurement



Gas Analysis



System Technology



Service

PFEIFFER  **VACUUM**

Pfeiffer Vacuum Technology AG · Headquarters/Germany

Tel. +49-(0) 64 41-8 02-0 · Fax +49-(0) 64 41-8 02-2 02 · info@pfeiffer-vacuum.de · www.pfeiffer-vacuum.net