



Installation & Parts Manual

MS-Series Spherical Two-Case Meters

**LIQUID
CONTROLS**
A Unit of IDEX Corporation

IDEX
IDEX CORPORATION



Installation: M100-20

www.lcmeter.com

Table of Contents

<u>Description</u>	<u>Page Number</u>	
Safety Precautions	3	Disassembling the Meter
How LC Meters Work	4	Draining Fluid from the Meter
Owner's Information Packet	5	Opening the Weldment Assembly
Installation Requirements	6	Removing Rotor Gears
System Design Considerations	7-10	Removing the Bearing Plate & Rotors ...
Operation Requirements	11	Removing Meter Housing Assembly
Meter Start Up and Operation	12-14	Universal Joint Assembly
Reversing the Meter Registration	13	Reassembling the Meter
Setting the Standard Adjuster	14	Installing the Meter
Meter Maintenance	15-16	Assembling the Meter
Servicing the Drive Components	17-20	Rotor Gear Timing
Removing the Dust Cover	17	Reassembling Weldment Assembly
Removing the Adjuster		Bolt Tightening Sequence
& Adjuster Driver Assembly	17-19	Wrench and Socket Size Chart
Servicing the Packing Gland	19	Fastener and Torque Chart
Packing Gland Components	20	Identification of Bolt Grades
The Retaining Plate	20	Troubleshooting
		How to Order Replacement Parts
		Parts Breakdown

Publication Updates and Translations

The most current English versions of all Liquid Controls publications are available on our website, www.lcmeter.com. It is the responsibility of the Local Distributor to provide the most current version of LC Manuals, Instructions, and Specification Sheets in the required language of the country, or the language of the end user to which the products are shipping. If there are questions about the language of any LC Manuals, Instructions, or Specification Sheets, please contact your Local Distributor.

⚠ **WARNING**

- Before using this product, read and understand the instructions.
- Save these instructions for future reference.
- All work must be performed by qualified personnel trained in the proper application, installation, and maintenance of equipment and/or systems in accordance with all applicable codes and ordinances.
- Failure to follow the instructions set forth in this publication could result in property damage, personal injury, or death from fire and/or explosion, or other hazards that may be associated with this type of equipment.

Please have the following information available when making inquiries, ordering replacement parts, or scheduling service. If a specific meter accessory is involved, please provide the model and serial number of the meter in question (see page 5).

Meter Serial Number _____

Full Service Distributor _____

Full Service Distributor Phone Number _____

NOTICE:

This manual provides warnings and procedures that are intended to inform the owner/operator of the hazards present when using the Liquid Controls Meter on LPG and other products. The reading of these warnings and the avoidance of such hazards is strictly in the hands of the owner/operator of the equipment. Neglect of that responsibility is not within the control of the manufacturer of the meter.

SAFETY PROCEDURES:

Remember to relieve internal pressure before disassembly or inspection of the strainer, vapor eliminator, valves, POD pulser, and the front or rear covers. See "Meter Maintenance" on Page 15 for the steps to relieve internal pressure in your system.

BE PREPARED:

- Make sure that all necessary safety precautions have been taken. Provide for proper ventilation, temperature control, fire prevention, evacuation, and fire management.
- Provide easy access to the appropriate fire extinguishers for your product. Consult with your local fire department, state, and local codes to make sure that you are adequately prepared.
- Read this manual as well as all the literature provided in your "Owner's Information Packet". If you have any questions, consult your full-service distributor or call the Service Department at Liquid Controls.

IN THE EVENT OF A GAS LEAK:

In the event of a large gas leak:

Evacuate the area and notify the fire department.

In the event of a small, contained gas leak:

1. Stop the leak.
2. Prevent accidental ignition.
3. Prevent entrance of gas into other portions of the building. Some gases, such as LPG, seek lower levels, while other gases seek higher levels.
4. Evacuate all people from the danger zone.
5. See that the gas is dispersed before resuming business and operating motors. If in doubt, notify your local fire department.

IN THE EVENT OF A GAS FIRE:

In the event of large fires or fires that are spreading:

1. Evacuate the building and notify your local fire department.
2. Stop the leakage only if the equipment can safely be reached.

In the event of small, contained fires that you can safely control:

1. Stop the leakage only if the equipment can safely be reached.
2. Use the appropriate extinguisher: Class B fire extinguisher, water, fog, etc., depending on the materials. If in doubt, call your local fire department.

WARNING

All internal pressures must be relieved before disassembly of the meter, strainer, vapor eliminator, any valves in the system, the pulse output device, or the front and rear covers. **LINE PRESSURE MUST BE 0.0 PSI.** See "Meter Maintenance" on Page 15 for the procedures to relieve internal

How LC Meters Work

Liquid Controls MS-Series meters are positive displacement flowmeters. They are designed for liquid measurement in both custody transfer and process control applications. Because of their simple design, they are easy to maintain, and can easily be adapted to a variety of systems.

The meter element (1) is designed with three cylindrical bores (2). A Blocking rotor (3) and two Displacement rotors (4,5) turn in a synchronized relationship within the bores. The three rotors are supported by bearing plates (6,7). The ends of the rotors protrude through the bearing plates. Blocking rotor gear (8) is placed on the end of the blocking rotor (3). Displacement rotor gears (9,10) are placed on the ends of the displacement rotors (4,5). These gears create the synchronized timed relationship between the three rotors.

As fluid moves through the meter element, the rotor assembly turns. The liquid is segmented into uniform sections by the turning rotors. Fluid displacement happens simultaneously. As fluid enters, another portion of the fluid is being partitioned and measured. At the same time, the fluid ahead of it is being displaced out of the meter and into the discharge line. Since the volume of the bores is known, and the same amount of fluid passes through the meter during each revolution of the blocking rotor, the exact volume of liquid that has passed through the meter can be determined.

This true rotary motion is transmitted through either the pulse output device (POD) to the encoder, or the face gear and drive shaft to the counter/register. True rotary motion output means consistent accuracy since the register indication is in precise agreement with the actual volume throughput at any given instant.

At any position in the cycle, the meter body, the blocking rotor, and at least one of the displacement rotors form a continuous capillary seal between the un-metered upstream product and the metered downstream product.

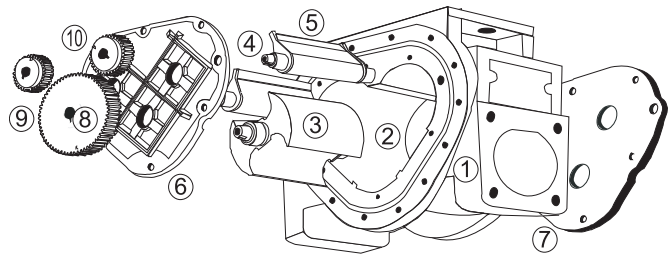

Capillary seals mean no metal-to-metal contact within the metering element. This means no wear. No wear means no increase in slippage, and no increase in slippage means no deterioration in accuracy.

Throughout the metering element, the mating surfaces are either flat surfaces or cylindrical faces and sections that are accurately machined. These relatively simple machining operations, plus the fact that there is no oscillating or reciprocating motion within the device, permit extremely close and consistent tolerances within the LC meter.

The product flowing through the meter exerts a dynamic force that is at right angles to the faces of the displacement rotors. The meter is designed so that the rotor shafts are always in a horizontal plane. These two facts result in no axial thrust. Therefore, with no need for thrust washers or thrust bearings, the rotors automatically seek the center of the stream between the two bearing plates eliminating wear between the ends of the rotors and the bearing plates.

Liquid Controls meters are made of a variety of materials to suit a variety of products. Because of our no-wear design, capillary seals, and unique rotary metering, LC meters provide unequalled accuracy, long operating life, and unusual dependability.

Blocking rotor

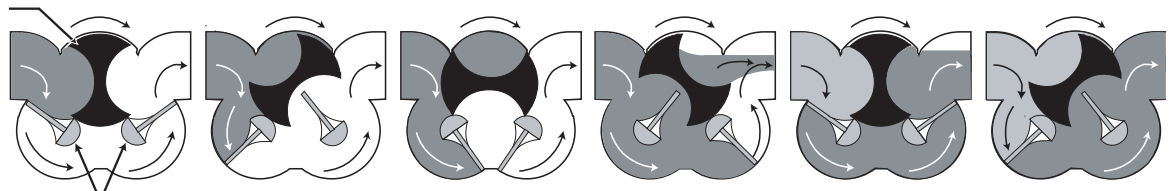

Displacement rotors

Owner's Information Packet

Is all the documentation included with the meter? LC meters come in many variations. The information sent depends on the accessories ordered with the meter. Make an inventory of the "Owner's Information Packet". First, find the LC packing slip with the computer printout. Locate the serial number and the meter model number on this printout. Cross-reference the packing slip with the actual meter serial numbers.

Included in the "Owner's Information Packet" are the following:

- Installation, Operation & Parts Manuals (for all elements supplied such as LectroCount Register, Valves, Air Eliminators, etc.)
- Bill of Materials

Record the meter serial number in the space provided on Page 2 of this manual. This page also provides a space for the full-service distributor's name and telephone number, if applicable. Fill in this information and keep it handy. The meter serial number and model number will be required when calling for service or parts. See "How to Order Replacement Parts" on Page 35 in this manual.

Serial Plates

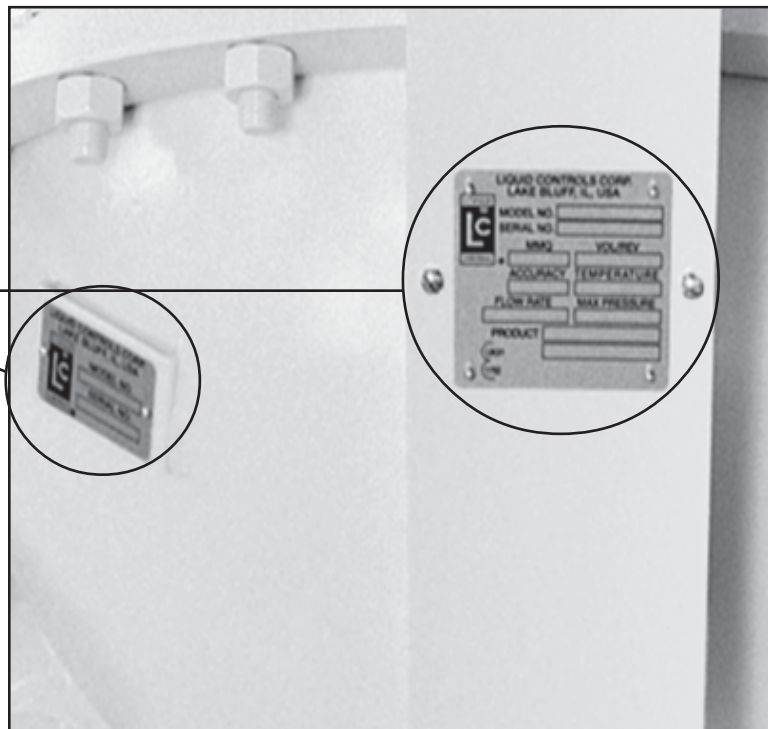

Installation Requirements

⚠ WARNING

All internal pressures must be relieved before disassembly of the meter, strainer, vapor eliminator, any valves in the system, the pulse output device, or the front and rear covers. **LINE PRESSURE MUST BE 0.0 PSI.** See “Meter Maintenance” on Page 15 for the procedures to relieve internal pressure.

- Make sure that all necessary safety precautions have been taken. Provide for proper ventilation, temperature control, fire prevention, evacuation, and fire management.
- Provide easy access to the appropriate fire extinguishers for the product. Consult with the local fire department and state and local codes to make sure that you are adequately prepared.
- Read this manual as well as the literature provided in the “Owner’s Information Packet”. If there are any questions, consult with the full-service distributor or call the Service Department at Liquid Controls.
- Install the meter and accessories in conformance with all applicable federal, state, local, construction, electrical, and safety codes.
- Class 10 meters for LPG must be installed in accordance with the requirements of ANSI-NFPA 58 in addition to all other state and local codes.
- Before shipment, protective thread caps were placed in all meter and accessory openings. They should remain in place until ready to attach piping.
- Prior to meter installation, the entire piping system should be thoroughly flushed of all debris, with a liquid that is compatible with the construction of the meter.
- Keep all external surfaces of the meter clean.
- The meter must always be securely bolted to a platform or supporting member, regardless of the mounting position of the meter. **Never “hang” a meter on the connecting pipe.**
- Prevent pipe strain or stress from occurring when making meter or accessory repairs. Pipe strain and stress occur when the pipes are not supported or are not aligned correctly to the meter. **The weight of the pipes must always be supported independent of the meter.** This means that the meter and accessories can easily be removed without affecting the pipes or the pipe alignment. Never leave any of the pipes hanging.
- Apply pipe compound to male threads only.
- Install the meter down stream of the pump.
- Position the meter with service in mind. Provide ample work space. Removing covers can be difficult when work space is not available. Always supply a platform or support for the meter mounting.
- A meter is metallurgically designed to be physically compatible with a given type of liquid, as originally specified by the customer, and as indicated on the Serial Number Plate. A meter should not be used with a liquid different from the liquid originally specified, unless the physical characteristics and pH rating are similar and the application has been checked with Liquid Controls Sales or Engineering.

NOTE: Always request up-to-date, engineering approved, dimensional drawings before starting any construction. Do not rely on catalog pictures or drawings which are for reference only. After receiving prints, check to see that all equipment ordered is shown and that any extra pressure taps, plugs, etc. are noted and their size specified.

System Design Considerations

Flowmeters must be installed properly if accuracy and repeatability of measurements are to be sustained over long periods of time. The system in which the meters are to be used must have provisions for controlling flow, transitional, and no flow conditions. Pressure, both hydrostatic and hydrodynamic, must be an integral part of the variables controlled in the flowing system. Systems in which meters are to be installed must be designed to eliminate transient pressure conditions, eliminate thermally induced pressure increases, and to exclude air or vapor.

The complete system must be kept full of product at all times. The photograph below is a typical fuel delivery gantry designed for loading rail tank wagons. This particular gantry has provisions for loading 152 rail tank wagons at one time. Four different fuels are supplied to the gantry through 16 inch pipe lines which are approximately ½ mile long. The pumps are centrifugal type and are located between 100 and 300 yards from the storage tanks.

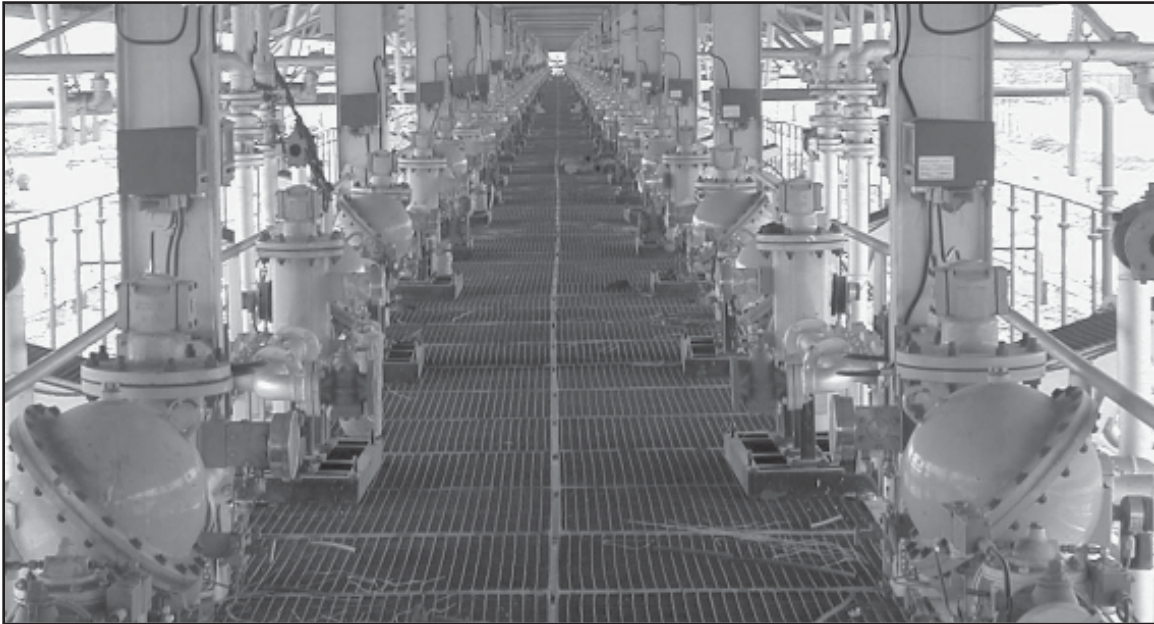

The next photograph shows a typical gantry position. From left to right, there is a supply line attached to an isolation valve, a second isolation valve and piping leading vertically to the loading arm. The meter is equipped with a dual channel, quadrature pulse

transmitter connected directly to a batch controller. The batch controller provides preset batch capability, flow rate control, and slow flow start and stop. There is one batch controller for each metering position.



System Design Considerations

Design For Calibration

Field calibration of meters is essential. Calibration conducted during meter production is to confirm the meter is capable of attaining the required accuracy/linearity and repeatability.

Typically, the meter characteristics are:

Mechanical Registration

- Repeatability: Capable of .02% or better at any flow rate over entire range
- Linearity: $\pm .125\%$ over a 5:1 range
- Linearity: $\pm .22\%$ over a 10:1 range
- Linearity: $\pm .5\%$ over a 40:1 range

Electronic Registration

- Repeatability: Capable of .02% or better at any flow rate over entire range
- Linearity: $\pm .1\%$ over a 5:1 range
- Linearity: $\pm .1\%$ over a 10:1 range
- Linearity: $\pm .15\%$ over a 40:1 range

The meters are normally tested against a master meter that has been proven against a Weights & Measures certified, volumetric prover.

The pictures below show a properly configured meter installation and mobile master prover. The prover connections are at the right. The two valves to the left of the meter are for connecting the volumetric prover or



Volumetric Prover

master meter to be used for calibration. The valve mounted in the vertical line between the two horizontally mounted valves is a double-block, bleed valve used to ensure there is no leakage through the valve during calibration.



Proper Meter Installation



Mobile Master Proving Trolley

Design for Standard Mounting Arrangements (straight through flow)

Regardless of meter mounting configuration, accessories such as the air/vapor eliminator must always be mounted in a vertical orientation to permit proper operation of the float-actuated apparatus.

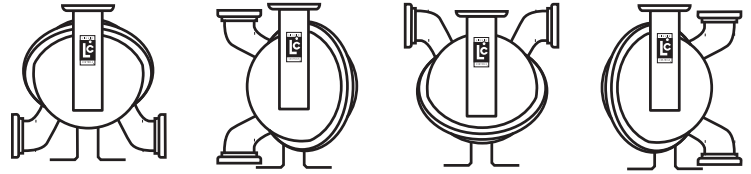

Design for Special Mounting Arrangements

Special flange arrangements are available as shown. Contact the factory for details or additional information.

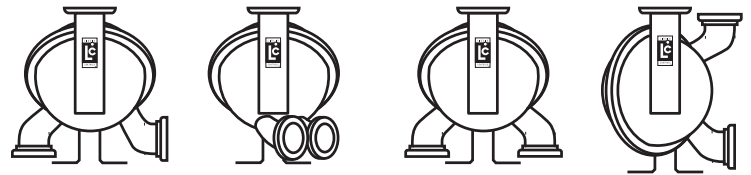

Design for Hot Oil/Steam Jacket Options

Heating a meter can be accomplished by hot oil/steam jacketing the meter's rear cover and/or packing gland boss. A heat jacketed meter does not preclude the necessity for insulating the meter and surrounding piping.

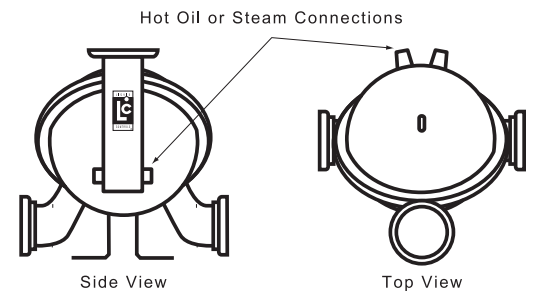

Design for Ensuring the System Remains Full of Product

The first consideration is merely filling the piping for the first time. The filling of the system must take place slowly in order to avoid pressure "spikes" or transients caused by rapid acceleration or deceleration of the liquid. Under gravity flow conditions, pressure transients in orders of magnitude larger than the available head pressure are possible.

At this time, air must be removed from the system. Make sure that a positive head condition is always present in the system (which should be designed into the system). Air or vapor in the system contributes to error in measurements while metering. Once air is removed from the system, ensure that the system design does not allow for air to re-enter the system once it is full of product.

System Design Considerations

Design for Thermal Shock or Expansion

Temperature considerations in system design should not be ignored. Care must be taken in the design so that zones are not created where fluid can be trapped or locked between two closed valves. For every 1°F increase in temperature, pressure in the trapped zone will increase by an amount depending on the product in the system (70 psi for LPG). A few degrees increase in ambient temperature may create a serious problem if thermal expansion pressure relief is not included in regions where the product may be trapped. Typically, the pressure setting in a thermal relief valve is set approximately 10% higher than the nominal operating pressure.

Design for Proper Flow Control

The example on Page 7 shows 152 meters monitoring the delivery of 4 different products. Thirty eight meters are used for delivery of HSD. Assume that one (1) pump is selected to supply product to the meters. Each meter measures 375 gallons per minute (GPM). The total flow capacity of the pump must be:

$$38 \times 375 \text{ GPM or } 14,250 \text{ GPM.}$$

Once the system is in operation, product flows through the first meter when the control valve is opened. If the flow rate is not regulated, 14,250 GPM attempts to flow through the meter. The resulting overspeed will immediately damage the meter. It is critically important that a each meter location be equipped with a digital or hydraulic flow rate controller. These valves must be downstream of the meter to ensure that the meter remains full of product at all times.

Control must also be used when beginning or stopping flow. Proper control will minimize or eliminate transient pressure conditions brought on by rapid velocity changes in the system.

Commissioning

Once the metering system is installed, it is ready for commissioning. Filling the system the first time requires care and time. Ensure that the isolation valve on the inlet side of the meter is closed. Pressure the header by starting the pump. At the meter position to be commissioned, “crack” or slightly open the inlet isolation valve until flow into the meter can be heard. Allow the inlet side to remain in this slightly opened position until flow stops.

At this time, “crack” or loosen the pipe plug on top of the meter case to allow air to bleed out. Once the air is eliminated and product is present, fully tighten the plug. Open the inlet side isolation valve completely. The system must be kept full of fluid to avoid damage to the meter. If air is allowed inside the metering element, significant damage can occur as this air expands or compresses due to system flow and pressure conditions. In extreme cases, the presence of air can cause catastrophic failure of the measuring element as a result of liquid velocities and transient pressure spikes that can bend or break critical measuring elements. The rate at which the system is filled and pressurized must be controlled to eliminate the possibility of creating any pressure transients from excessive liquid velocity. Once the meter and system are filled, pressurized, and free of air, flow may begin.

Care must be taken during the initial flow condition to prevent damage to the meter or strainer due to foreign debris in the piping system. Foreign particles not removed during flushing and hydrotesting will collect in the strainer basket. Monitor the strainer differential pressure for the first month of operation. Clean the strainer basket if needed. Examine the strainer basket carefully and replace if damaged.

Assure that the thermal relief valves are installed and functioning properly.

The meter must remain full of product at all times.

An easy way to accomplish this is to put the meter assembly in the line below the piping center-line (a sump position). This requires adding elbows and flanges prior to installing the meter. The meter should be installed with a bypass loop, below the pipe center-line, with block valves upstream and downstream. A block valve should be located in the mainstream, labeled as the bypass valve. **A word of caution:** any portion of pipe system that might isolate or block flow should be provided with a pressure relief to prevent damage from thermal expansion. There are excellent benefits to this type of installation. First, the meter is kept full. Second, this type of installation allows the meter to be isolated for servicing and calibration while continuing flow through the bypass valve.

Upstream lines must be maintained full to prevent air from entering the meter. If the upstream or inlet lines are constructed in a manner which allows reverse flow, foot valves or back checks must be installed.

NOTE: Use soft seats, not cast iron swing checks.

Every meter should be calibrated under actual service and installation conditions per the API Manual of Petroleum Measurement Standards:

Chapter 4: Proving Systems

Chapter 5: Metering

Chapter 6: Metering Assemblies

Chapter 11 Section 2.3: Water Calibration of Volumetric Provers

Chapter 12 Section 2: Calculation of Petroleum Quantities

These chapters of the API Manual of Petroleum Measurement Standards supersede the API Standard 1101.

Provide a means of conveniently diverting liquid for calibration purposes.

Give careful attention to your system's pumping equipment and piping because of their influence on liquid being measured as it enters the meter assembly. Systems should be made free of conditions that cause or introduce entrained air or vapor.

Follow the manufacturer's recommendations fully when installing pumps. Give particular attention to factors like: use of foot valves, pipe size to the inlet and conformance to net positive suction head (NPSH) conditions when suction pumping is required. Following the manufacturer's recommendations will minimize air and vapor elimination problems.

For all products, it is desirable to use flooded suctions and piping sized larger than the normal pump size.

Hydraulic shock is harmful to all components of an operating system including valves, the meter and the pump. In particular, meters must be afforded protection from shock because of their need to measure with high precision. Generally the best protection is prevention, which can be readily accomplished by adjusting valve closing rates in such a manner that shock does not occur. Shock pressure and system pressure are independent of each other.

Thermal expansion like hydraulic shock is a phenomenon that can easily damage meters and systems in general. Care should be taken in designing the system to include pressure relief valves in any portion or branch of the system that might be closed off by closure of operating valves or block valves. Note that 1°F is equivalent to an increase amount depending on the product in the system (70 psi for LPG).

⚠ WARNING

Under normal operation, do not expose any portion of the LP-Gas system to pressures in excess of rated working pressures without an automatic safety valve to vent the over pressure discharge to a place of safety away from the operator and other people. Failure to provide such a safety relief may result in leakage or rupture of one or more of the components in the system. This can result in injury or death from the gas, a fire, or pieces of flying debris from the rupture.

When a Back Check Valve is used, an automatic safety valve must be installed to prevent pressure buildup (thermal expansion) in excess of rated working pressure in the meter housing. One automatic safety valve should be installed in each meter. Remove the pipe plug from the front cover or rear cover and insert the appropriate automatic safety valve.

Meter Start Up and Operation

Prior to meter start up, use extreme caution. Make sure that:

1. The meter is properly secured
2. All connections are tight
3. All valves are in the closed position

Placing your meter in operation:

Check to determine that all fittings and flanges are tight and liquid lines are closed.

Open the vapor line to the meter. Using vapor pressure only, check each joint with a liquid soap solution to see that no leaks go undetected. When all joints have been checked, admit liquid SLOWLY to avoid operation on vapor at speeds greater than the maximum indicated on the serial number plate and to insure that cover cavities do not contain vapor which can be compressed. Proper slow filling can be done by throttling the system with a valve at the meter OUTLET.

With the valve(s) open between the tank and the meter, go to the valve located down stream of the meter. Open the down stream valve slowly until the meter's register/counter starts to move. Do not run the meter any faster than 25% of its maximum rated flow during start-up. Once the product is flowing out the end of your system, the outlet valve can be opened all the way provided that the system is designed not to exceed the flow rate marked on the meter.

NOTE: If the valves are not manual, consult the valve manufacturer for slow flow start-up.

Filling the system with a pump:

Consult the pump manufacturer for proper pump priming. Once the pump is primed with product, proceed.

NOTE: Make sure that your pump can operate against a dead head pressure. If NOT, consult the factory for assistance.

Never operate the meter or system when partially filled with liquid, or with pockets of compressed air or vapor present. If these conditions cannot be avoided, air and vapor elimination systems may be required. If you cannot fill the meter slowly by gravity or by using a valve to throttle back the flow, consult the factory.

- Do not operate the meter at a pressure exceeding that marked on the Serial Number Plate. Under any and all pressure producing circumstances, for instance, thermal expansion and hydraulic shock, the working pressure must not exceed the indicated maximum.
- If the meter is operated at a rate greater than the maximum recommended GPM, excessive wear and premature failure may occur.

The meter can be calibrated for flows below minimum ratings if the flow remains constant and varies within narrow limits or if the product is viscous. A meter should never be run beyond the maximum flow rate determined for that class meter and/or liquid measured.

Electronic Registration

Liquid Controls' family of LectroCount® electronic registers provide near-perfect metering accuracy over a full range of flow rates and deliver enhanced functions including: automated data collection (i.e., date, time, product, delivery quantity and more), on-site ticket generation, meter linearization, electronic temperature volume compensation, real-time communication capabilities (RF, GPS, CDPD), improved security and more.



Reversing the Meter Registration

The direction of flow is specified by the customer when the meter is ordered. The standard direction of flow is from left to right when facing the front of the meter. A red, pressure sensitive label indicating the inlet is affixed to the meter at the time of shipment.

If the meter is equipped with a strainer and/or valve, the strainer and/or valve **MUST** be moved when reversing the direction of flow through the meter. **The strainer should always be located on the inlet side of the meter.** When the meter is equipped with a valve, it is moved to the outlet side of the meter. Some repositioning of the valve components may be required. See the Valve Manual in the Owner's Information Packet.

When the meter is first installed, check the register. If the register counts **DOWN** (numbers decrease) the direction of registration must be reversed by either reversing the position of the adjuster drive gear or by reprogramming the direction of flow using the Lap Pad (for LectroCount electronic registration). Consult the LectroCount Operation Manual provided in the Owner's Information Packet.

Reversing the drive to the register is accomplished by reversing the position of the adjuster drive gear relative to the pinion gear of the packing gland.

Adjuster drive gear engaged from the top.

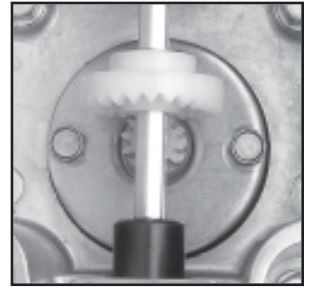

Adjuster drive gear engaged from the bottom.

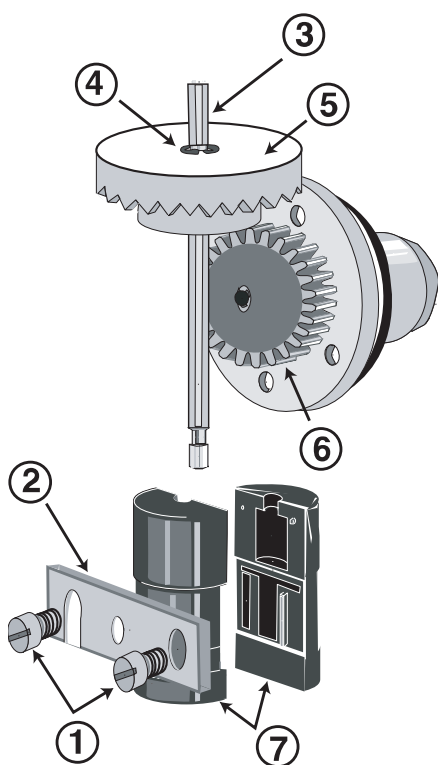
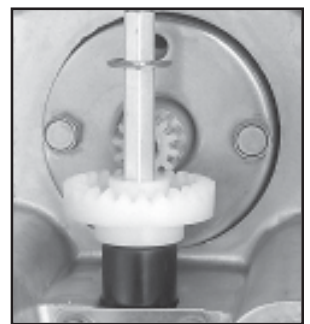

1. See Meter Maintenance on Page 15 and "Servicing the Drive Components" on Page 17, for instructions on removing the dust cover.
2. Remove the retaining spring screw(s) (1) with a standard screwdriver.
3. Remove the retaining spring (2).
4. Remove the drive shaft (3) mounted with the adjuster driver gear assembly (4, Retaining Ring) (5, Adjuster Drive Gear).
5. Remove the retaining ring (4) with a screwdriver or pliers.
6. Remove the adjuster driver gear (5) and turn it 180° so that it is upside down from the original installed position. The bushing (7) supports the adjuster drive gear in the lower position. The retaining ring (4) supports the adjuster drive gear in the upper position.
7. Reassemble the parts in reverse order. Make sure that the adjuster driver gear meshes with the packing gland's pinion gear (6) without being too tight. Make sure there is a little play in the gear teeth. The retaining ring (4) should be placed in the groove provided on the drive shaft (3) regardless of the adjuster drive gear position. The packing gland pinion gear to adjuster drive gear ratio is either 1:1 or 2:1. In the 2:1 ration, the pinion of the packing gland is smaller in diameter.

Setting the Standard Adjuster

Note: These instructions apply to meters equipped with mechanical output accessories only. If the meter is equipped with an electrical output assembly, refer to the accessory manual, such as the Pulser Manual or LectroCount Manual in your Owner's Information Packet.

1. See Meter Maintenance on Page 15, and "Servicing the Drive Components" on Page 17, to remove the dust cover.
2. Check meter registration by delivering product to a reliable, accurate prover. Perform multiple delivery tests to verify the meter repeatability.
3. Record the setting indicated on the adjuster.
4. Note the volume in the prover. Calculate the difference between the counter and prover volume. Multiply the result by 100. Refer to the formula below.
5. Loosen the adjuster clamp screw.
6. When the prover volume is less than the meter counter volume, add the percentage to the original adjuster setting by turning the thimble towards the arrow marked LARGER (volume). Correct the original setting by approaching the number desired from the next larger number. For example, a desired adjuster setting is "3.4". Turn the adjuster thimble to the left to number "4", then to the right to obtain the "3.4" setting.
7. When the prover volume is more than the meter counter volume, subtract the percentage from the original adjuster setting by turning the thimble in the direction of the arrow marked SMALLER (volume).
8. Retighten the adjuster clamp screw. Run product through the meter to allow the adjuster to take set. Then make several prover runs to check for accuracy and repeatability.

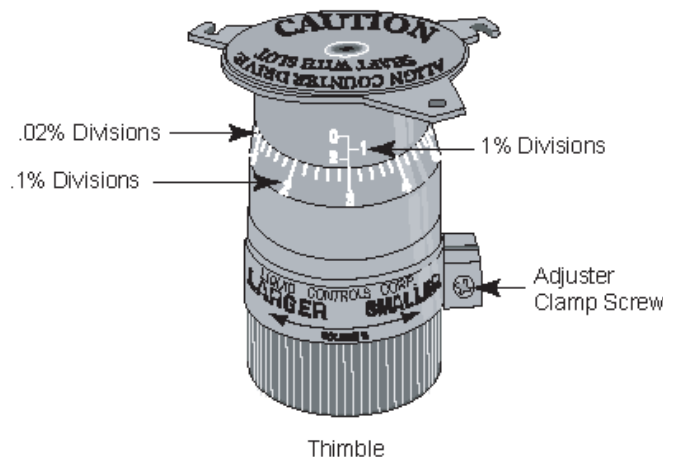
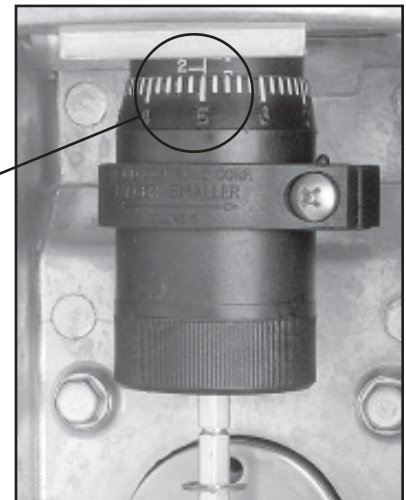

$$\% \text{ CORRECTION} = \frac{\text{VOLUME IN PROVER} - \text{VOLUME ON METER COUNTER}}{\text{VOLUME IN PROVER}} \times 100$$

⚠ WARNING

RELIEVING INTERNAL PRESSURE

All internal pressure must be relieved to zero before disassembly or inspection of the strainers, air eliminators, valves, the pulse output device (POD), or the front and rear covers.

Serious injury or death from fire or explosion could result from maintenance of an improperly depressurized and evacuated system.

Procedure for Non-LPG Meters

1. Turn off pump pressure.
2. Close valves before and after the meter.
3. Remove pressure by cracking open the drain plugs until pressure is relieved. Then open the drain plugs completely and drain the meter.

Procedure for LPG System Meters

1. Close the belly valve of the supply tank.
2. Close the valve on vapor return line.
3. Close the manual valve in the supply line on the inlet side of the meter. If no manual valve exists on the inlet side, consult the dispenser manufacturer for procedures to depressurize the system.
4. Slowly open the valve/nozzle at the end of the supply line.
5. After product has bled off, close the valve/nozzle at the end of the supply line.
6. Open the bleed valves located on the strainer cover and meter cover (if equipped) to relieve pressure in the system. Product will drain from the meter system.

Caution: If the systems contains a Back Check Valve, pressure inside the meter housing **MUST** be relieved by opening the bleed valve in the meter cover (if equipped) or by loosening one of the pipe plugs in the meter cover. This procedure must be done for each meter.

7. As product is bleeding from the bleed valve, slowly reopen and close the valve/nozzle on the discharge line. Repeat this step until the product stops draining from the bleed valve and discharge line valve/nozzle.

Meter Maintenance

Prevent pipe strain or stress from occurring when making meter or accessory repairs. Pipe strain and stress occur when the pipes are not supported or are not aligned correctly to the meter. The weight of the pipes must always be supported independent of the meter. This means that the meter and accessories can easily be removed without affecting the pipes or the pipe alignment. Never leave any of the pipes hanging.

Seasonal meter storage. If the meter is used for seasonal work, at the end of each season the meter should be removed from the system and thoroughly flushed with a compatible liquid. This includes removing the drain on the front and rear covers. Then flush the product from the front and rear covers. If flushing with water is preferred, extra care should be taken to drain the meter completely and to dry all internal parts. Immediate refilling with a compatible liquid (or oil misting) is essential to prevent corrosion as well as ice damage to parts from moisture that was overlooked after flushing and drying.

Do not mar or scratch any of the precision machined surfaces by prying or sanding parts.

Torque specifications. All fasteners such as screws and bolts should be torqued to proper specification. See the "Torque Chart" on Page 31 of this manual.

Stone the machined surfaces when reassembling the meter to assure that the machined surfaces are free of burrs and mars.

Repair pulled threads with threaded insert fasteners. These can be used in many instances. Contact your full-service distributor for advice if this occurs.

Coating threads. When removing and replacing bolts and castings in a meter, always coat the threads with anti-seize.

Removing flange seals. When removing the flange assembly, always carefully remove the O-ring seal. Make sure that the flange surface is clean. Discard and replace the old O-Ring seal if it is nicked or scratched in any way. If it is undamaged, it can be reused.

Examine all fasteners. Make sure fasteners are not bent, rusted, or have pulled threads. The threads should all appear evenly placed. If the bolts are bent, check the housing and bearing plate for flatness. Use a straight edge to determine flatness.

Look for gaps. When disassembling a meter, use a feeler gauge to check for gaps between the bearing plate and housing. If you do find gaps, check the bearing plates for flatness with a straight edge. Gaps can be caused by shock problems that must be resolved. Contact your full-service distributor or the Service Department at Liquid Controls for assistance if this occurs.

Check the O-Rings. O-Rings should be smooth. Cracked or worn O-Rings should be replaced. However, a more serious problem of shock may have occurred if the O-Rings look nibbled. Shock problems must be verified and resolved. Contact your full-service distributor or the Service Department at Liquid Controls for assistance if this occurs.

Check the bearing plates. Check the bearing plates for flatness. Use a straight edge. Warped bearing plates can be caused by shock problems that must be resolved. Contact your full-service distributor or the Service Department at Liquid Controls for assistance if this occurs.

Weights & Measures. Check with the regulatory agency that governs Weights & Measures in your area. Removing a seal wire may require Weights & Measures recalibration.

Servicing the Drive Components

Removing the Dust Cover

1. Cut the dust cover seal wire (if present) with a side cutters. Remove the dust cover screws with a flat blade screwdriver. Remove the dust cover.

NOTE: See Relieving Internal Pressure and Weights & Measures in the Meter Maintenance section on Page 15 of this manual.

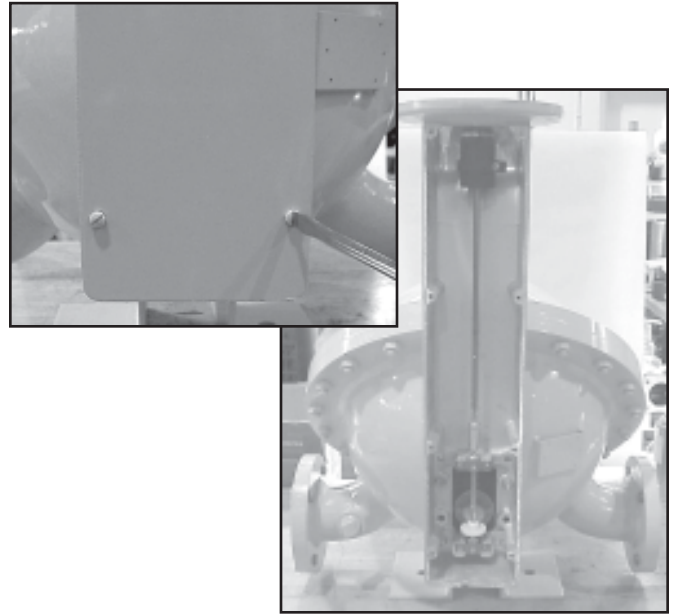

Removing the Adjuster and Adjuster Drive Assembly

2. Record the Adjuster Micrometer setting.

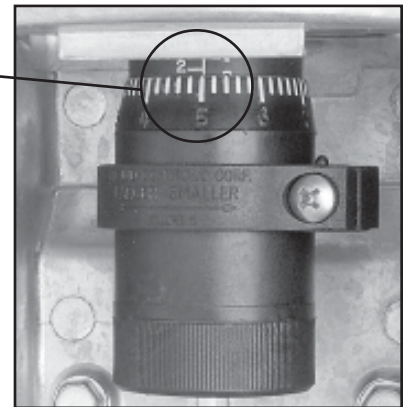

3. Carefully note the adjuster drive gear position. The gear engages the packing gland pinion from below (shown) or above. The gear must be reinstalled in its original position or the register counter will run backwards.

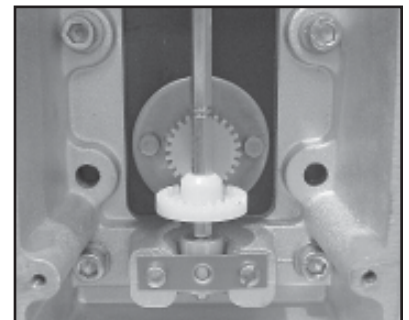

Servicing the Drive Components

Removing the Adjuster and Adjuster Drive Assembly (Continued)

4. Use a flat blade screwdriver to remove the two screws of the upper retaining spring.

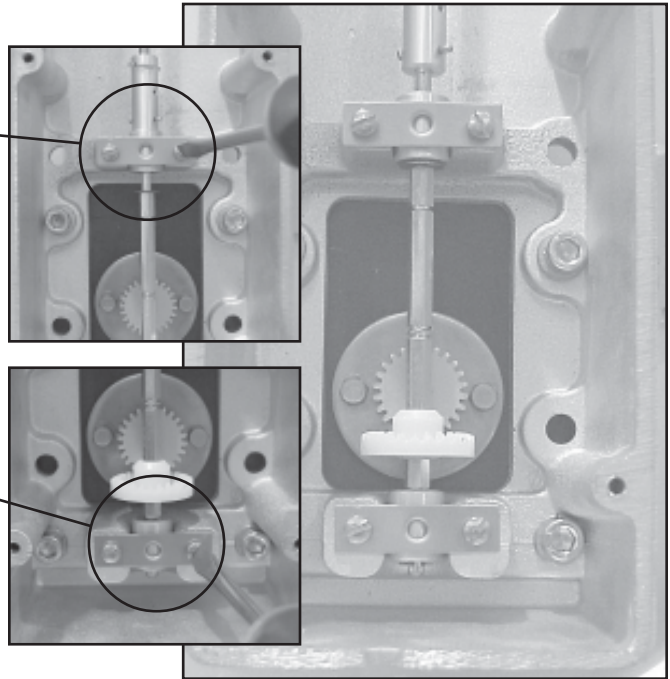

5. Use a flat blade screwdriver to remove the two screws of the lower retaining spring.

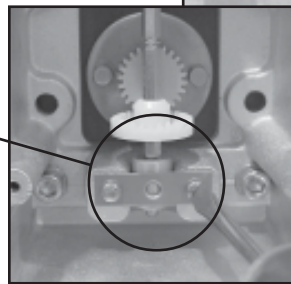

6. Remove the drive assembly.

If there is a need to remove the entire counter adapter assembly, remove the 4 screws located at the bottom end of the assembly.

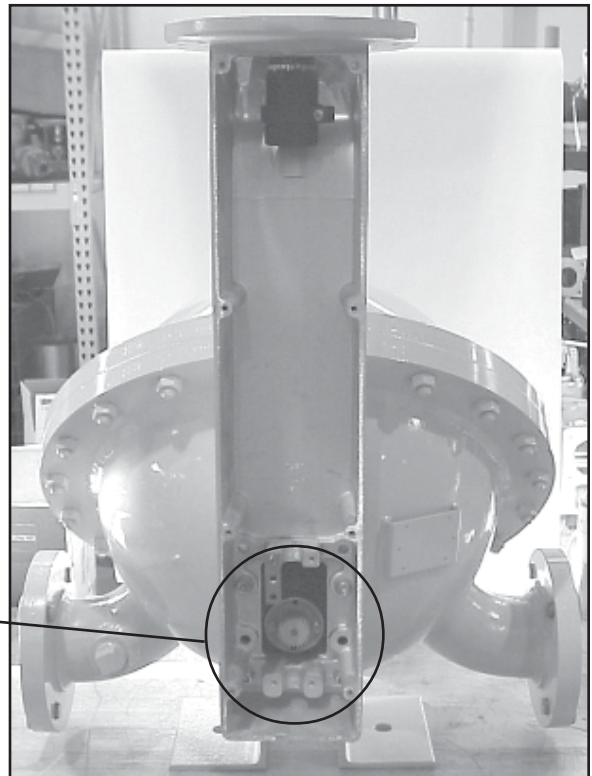

Servicing the Drive Components

Removing the Adjuster and Adjuster Drive Assembly (Continued)

7. Remove the Adjuster assembly by removing the single screw holding it in place. The adjuster can then be rotated clockwise and removed from below.

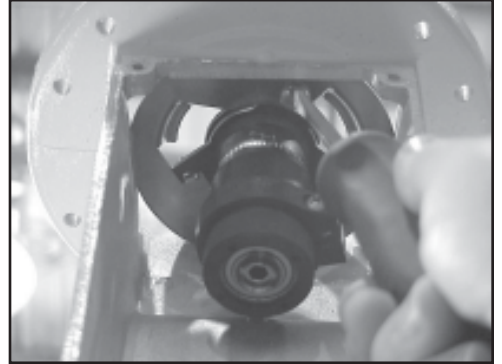

Removing the Packing Gland

⚠ WARNING

All internal pressures must be relieved before disassembly of the meter, strainer, vapor eliminator, any valves in the system, the pulse output device, or the front and rear covers. **LINE PRESSURE MUST BE 0.0 PSI.** See "Meter Maintenance" on Page 15 for the procedures to relieve internal pressure.

8. Remove the two packing gland retaining plate screws with a 5/16" socket and ratchet driver extension or 5/16" nut driver.

NOTE: It is not necessary to completely remove the stack from the meter to service the packing gland.

9. Pull out the packing gland. There is an O-Ring for the packing gland which may not come out with the packing gland. If it does not come off with the packing gland, it will be located in the packing gland well.

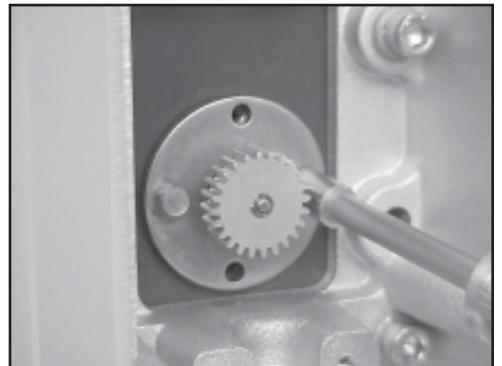

The packing gland may be taken apart by removing the retaining ring from the gear end of the assembly.

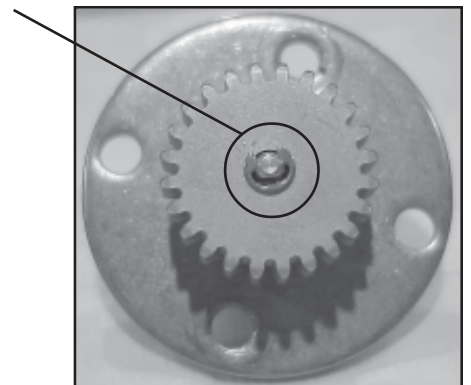
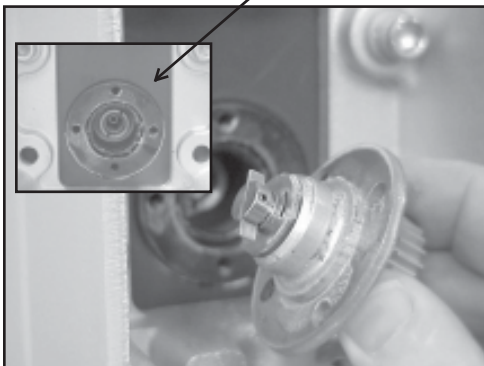

Servicing the Drive Components

Standard Packing Gland

1. Housing
2. Drive Blade
3. Bushing
4. Shaft
5. Retaining Clip
6. "U" Cup
7. Rulon Thrust Washer
8. Stainless Steel Thrust Washer
9. Nylon Washer
10. O-Ring
11. Retaining Plate
12. Retaining Plate Screws (2)
13. Roll Pin
14. Output Gear 1:2
15. Output Gear 1:1

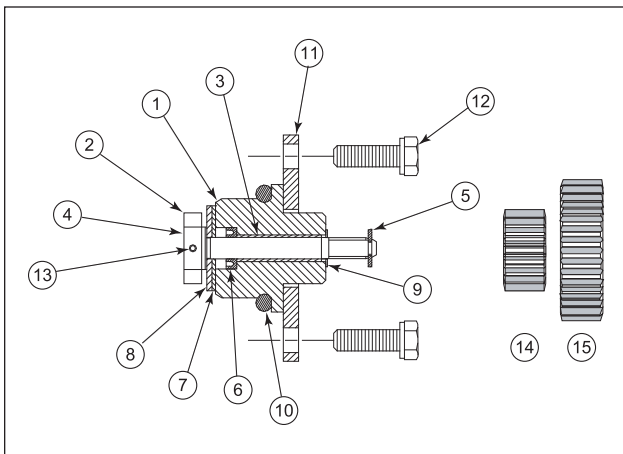

LPG Packing Gland

1. Housing
2. Drive Blade
3. Bushing
4. Shaft
5. Retaining Clip
6. "U" Cup
9. Stainless Steel Washer
10. O-Ring
11. Retaining Plate
12. Retaining Plate Screws (2)
13. Roll Pin
14. Output Gear 1:2
15. Output Gear 1:1
16. Carbon Guide Bearing

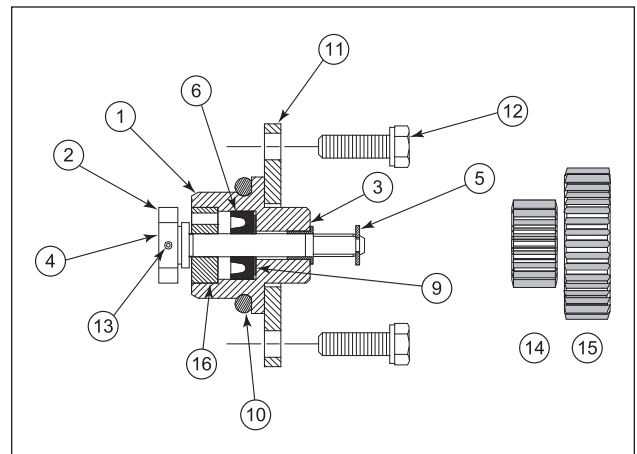

The Retaining Plate

The retaining plate has four holes"
 Two that are drilled 1.5" on center
 Two that are drilled 1.625" on center.

Turn the retaining plate until the holes match up with the threads to determine which orientation is correct for the meter being serviced.

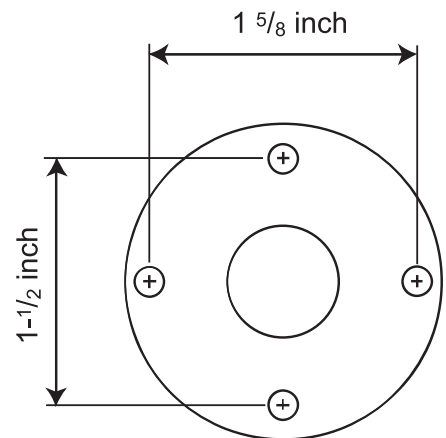

Disassembling the Meter

Tools:

Torque Chart
Wrench & Socket Size Chart
Counter bracket wrench or socket
Drain plug wrench
Cover socket or open end/box end wrench

Standard screwdrivers (2)
Spare displacement rotor gear
Bearing plate wrench
Plastic or rubber mallet
Emery cloth
Wire brush

(See Pages 31 & 32 for the Torque and Wrench & Socket Size Charts)

⚠ WARNING

All internal pressures must be relieved before disassembly of the meter, strainer, vapor eliminator, any valves in the system, the pulse output device, or the front and rear covers. **LINE PRESSURE MUST BE 0.0 PSI.** See "Meter Maintenance" on Page 15 for the procedures to relieve internal pressure.

Draining Fluid from the Meter

1. After the internal pressure has been relieved, open the drain plugs located at the bottom of the weldment assembly and discharge arm to drain all fluid from the weldment assembly.

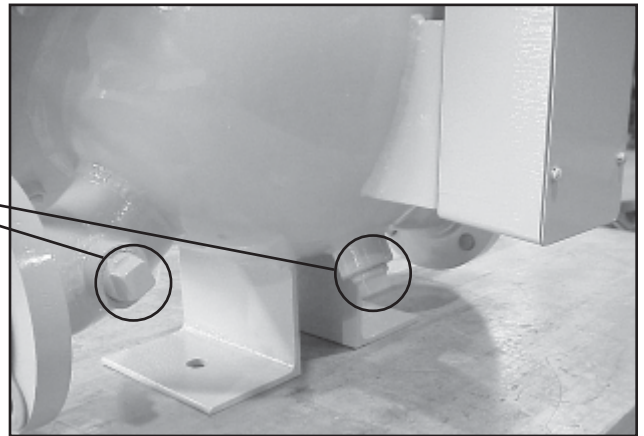

Opening the Weldment Assembly

2. Once the system has been completely drained, the weldment assembly may be opened by removing the cover screws and bolts that are located around the rim of the enclosure.

The number of bolts may vary between the different meter sizes.

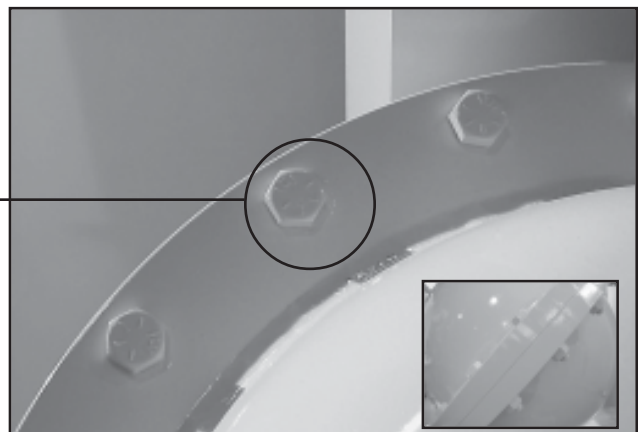

Disassembling the Meter

- When all the screws and bolts have been removed, remove the weldment cover. This exposes the inside of the weldment assembly and provides access to the meter assembly. The meter assembly is held in place by 4 bolts on the inlet side of the meter. This can be either side of the meter depending on the direction of flow.

Access to these four bolts is gained by removing the front bearing plate of the meter housing.

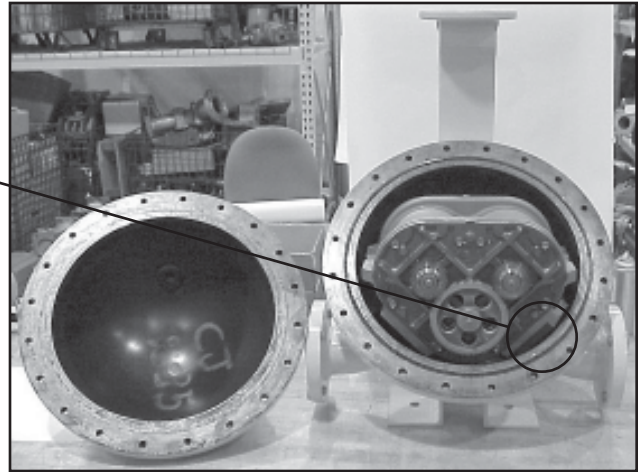

- Remove the O-Ring from the weldment assembly. Undamaged O-Rings may be reused.

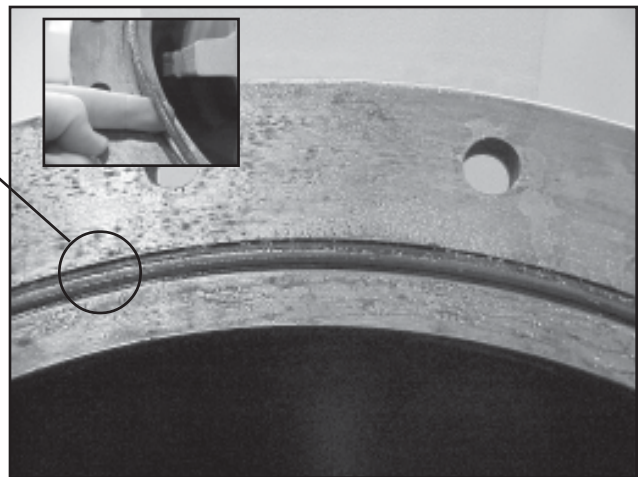

Removing the Rotor Gears

- Hold a spare displacement rotor gear between the right displacement rotor gear and the blocking rotor gear to keep them from turning. If a spare gear is not available, use a shop rag between the gear teeth. Use the rotor gear allen key to loosen the rotor gear screw by turning it counter-clockwise. Do not remove the screw completely.

NOTE: Do not use a metallic tool for locking the gears as this will likely result in damage to the gear teeth.

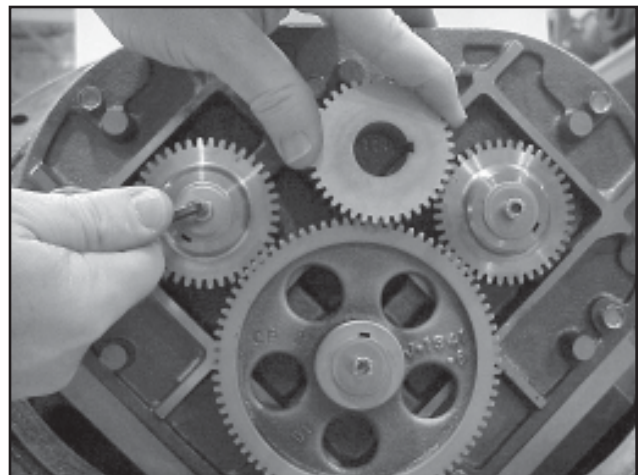

Disassembling the Meter

6. Keeping the spare displacement gear between the right rotor gear and blocking gear, use the allen wrench to loosen the screw of the right rotor gear assembly.



7. To loosen the screw of the blocking rotor gear, move the spare displacement rotor gear to between the left rotor gear and the blocking rotor gear to prevent the gears from moving.

Once all the screws are loose, remove the screws and washers completely from each of the 3 gear assemblies.

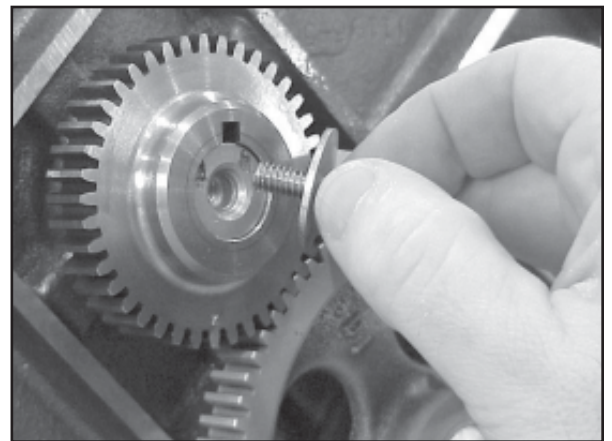
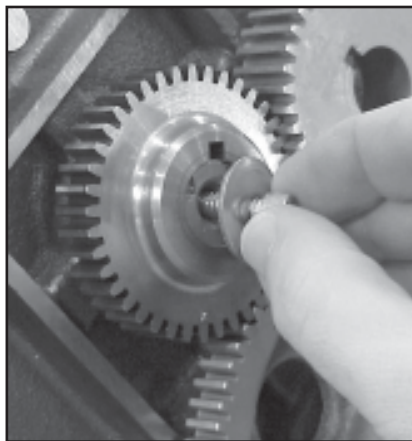
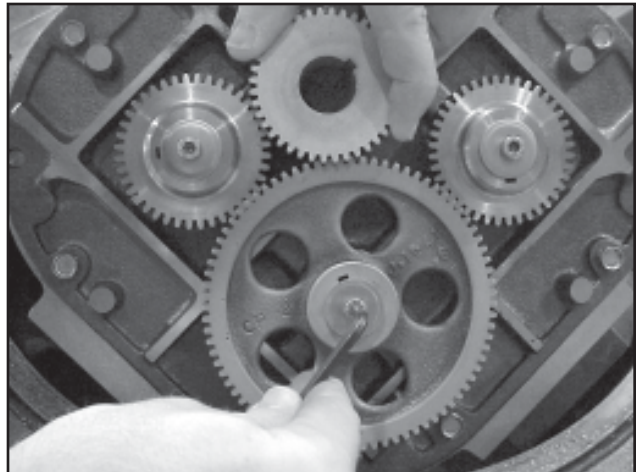

Disassembling the Meter

Removing the Rotor Gears

- Using one or two flat blade screwdrivers, gently pry the gear off its rotor tapered end. Do this for each of the gears.

As the rotor gear comes off, remove the key (1) from the rotor keyway (2). Save the key to use when reassembling.

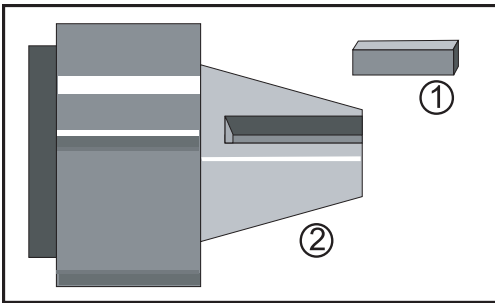
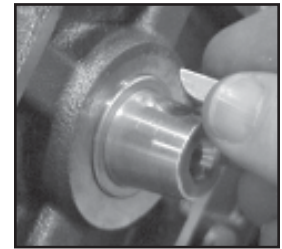
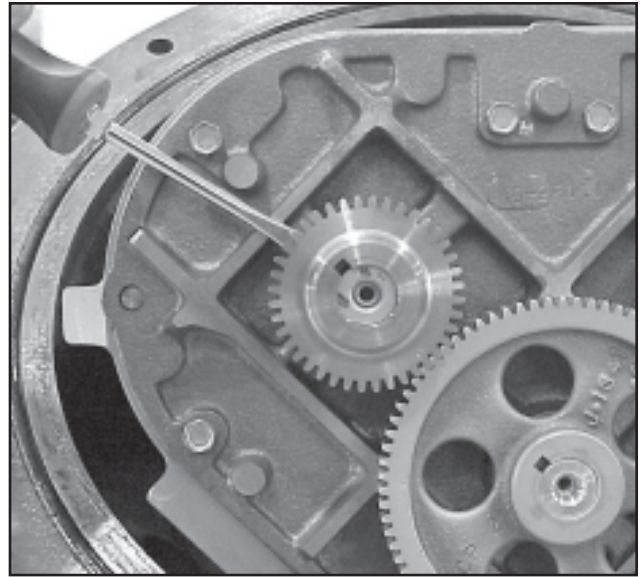

Removing the Bearing Plates and Rotors

- Use the bearing plate wrench or nut driver to remove the screws that hold the front bearing plate to the meter housing. The number of screws varies between the different meter sizes.

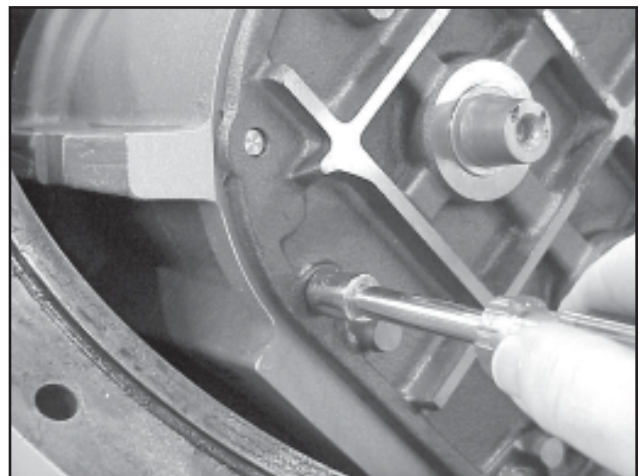

Disassembling the Meter

10. When all the bolts are removed, insert a screwdriver into each of the two notches near the dowel pins. Be careful not to mar any of the surfaces. Gently pry the front bearing plate off the dowel pins. Remove the front bearing plate and rotor assemblies by pulling a rotor straight out from the housing. Be careful not to mar any of the surfaces.

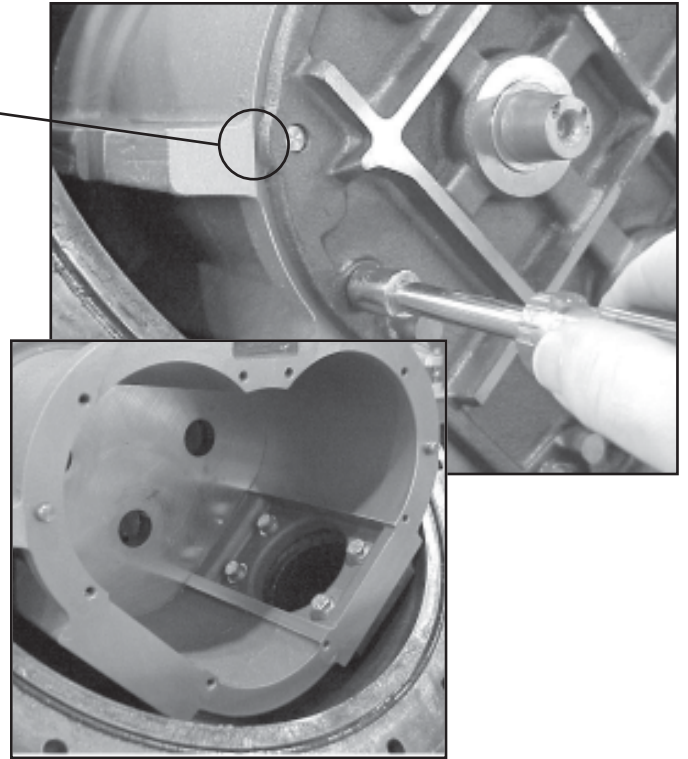

Removing the Meter Housing Assembly

11. The meter housing assembly is held in place by four bolts. Remove these using an impact or socket wrench. There is a flat gasket between the meter housing and the weldment housing. Inspect this gasket for damage and replace as needed.

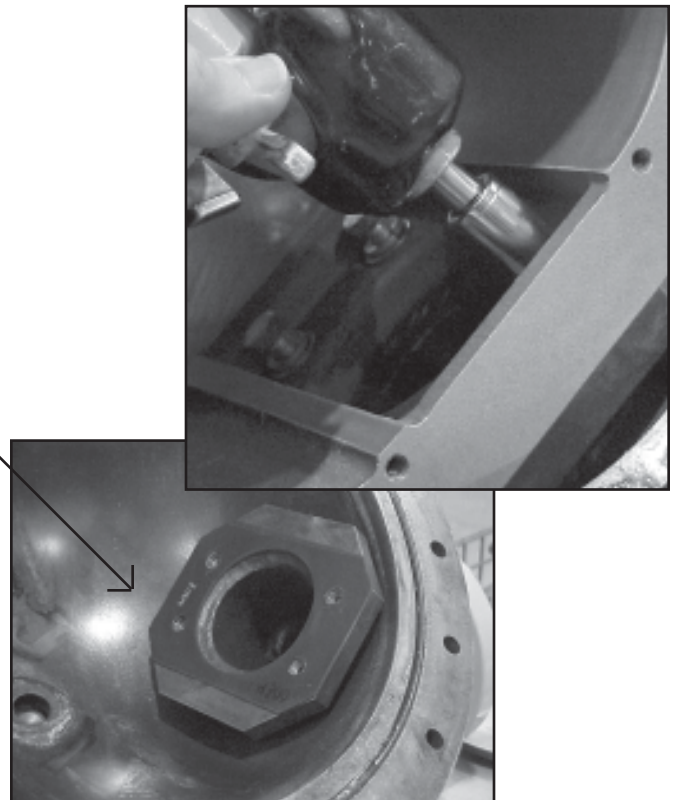

Disassembling the Meter

Universal Joint Assembly

12. The Universal Joint is an extension used to connect the blocking rotor of the meter to the packing gland. When the blocking rotor rotates, the Universal Joint causes the packing gland to rotate which drives the register. This assembly extends through the back of the meter and into the weldment wall through the drive coupling bearing.

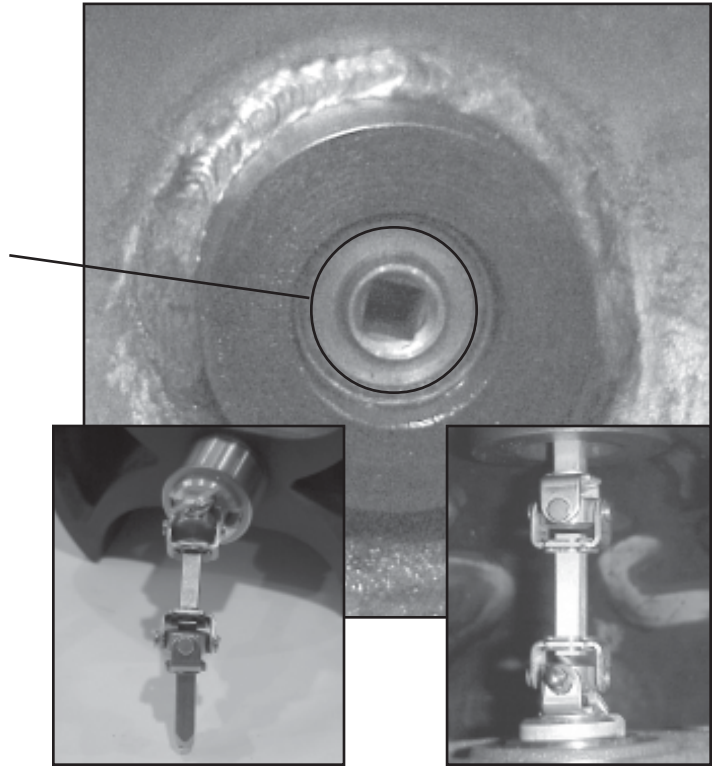

Universal Joint Components

- | | |
|-----------------------|--------------------|
| 1. Screw, #8-32 | 7. Drive Coupling |
| 2. Retaining Ring (3) | 8. Driver Packing |
| 3. Retaining Ring (3) | 9. U-Joint Bracket |
| 4. U-Joint Pin (8) | 10. Coupling |
| 5. Lock Washer | 11. Trunnion |
| 6. Coupling | |

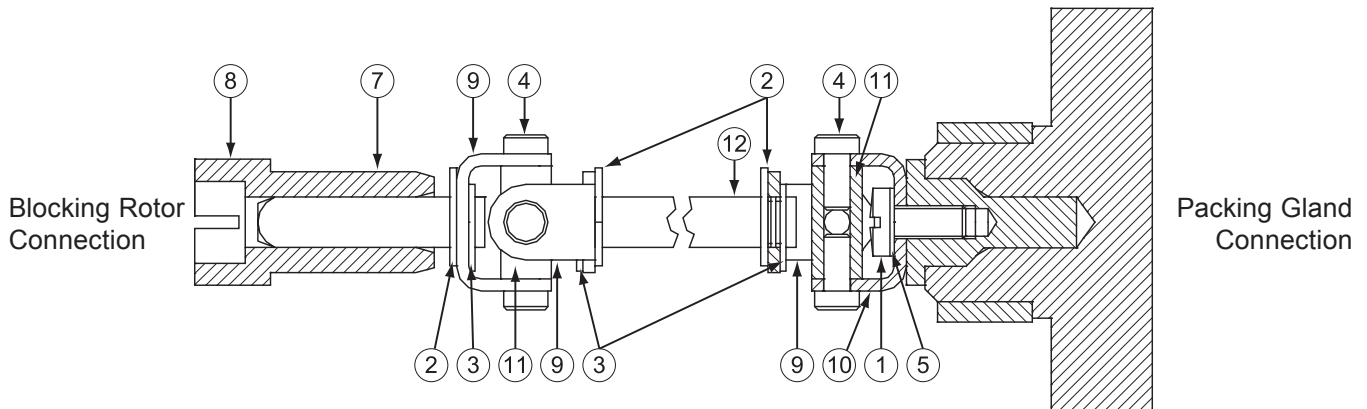

Reassembling the Meter

Tools:

Cover socket or open end/box end wrench
Spare displacement rotor gear or shop rag
Rotor gear wrench or socket
Bearing plate wrench or socket

NOTE: The principles of meter disassembly and reassembly are the same for all Liquid Controls meters. Although your meter may look slightly different than those pictured, the steps are the same, except as noted.

(See Pages 31 & 32 for the Torque and Wrench & Socket Size Charts)

Installing the Meter

1. Place the flat gasket in the lower weldment and line up the bolt holes. Position the meter housing in the weldment lower hemisphere and secure using the four bolts. Use care not to damage the flat gasket. Use an impact driver or socket to tighten bolts.

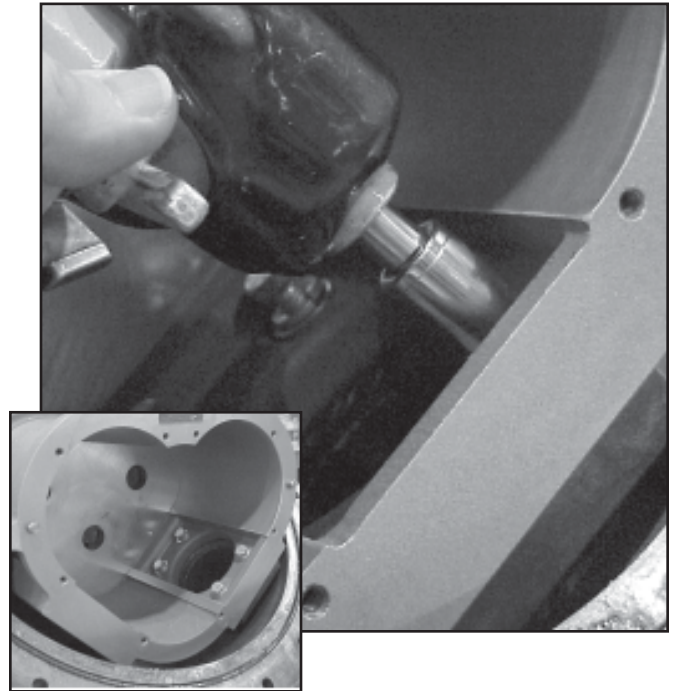

Assembling the Meter

2. Install the blocking rotor. It will be necessary to guide the universal joint assembly into the drive coupling bearing and packing gland by reaching behind the meter element.

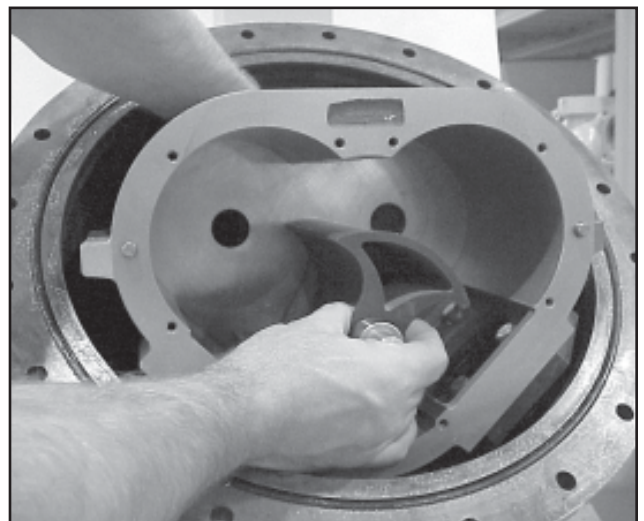

Reassembling the Meter

3. Install the two displacement rotors. Insert the non-tapered ends into the housing. Place each rotor into its respective bore on the bearing plate.

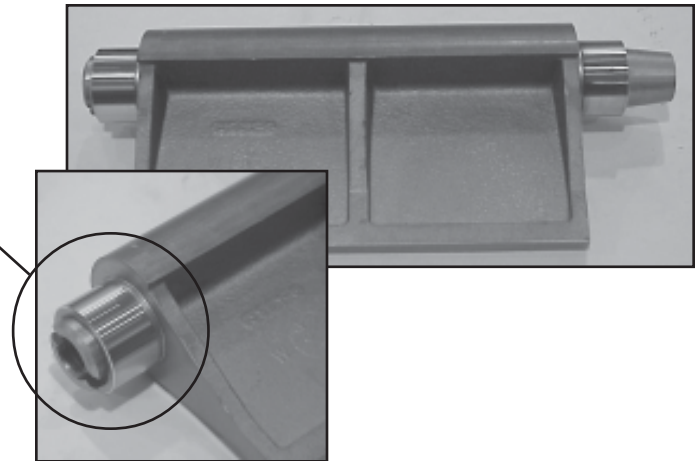

4. Install the bearing plate cover over the three tapered ends and fasten it with the bearing plate screws. Use the bearing plate wrench. The number of screws varies between different meter sizes.

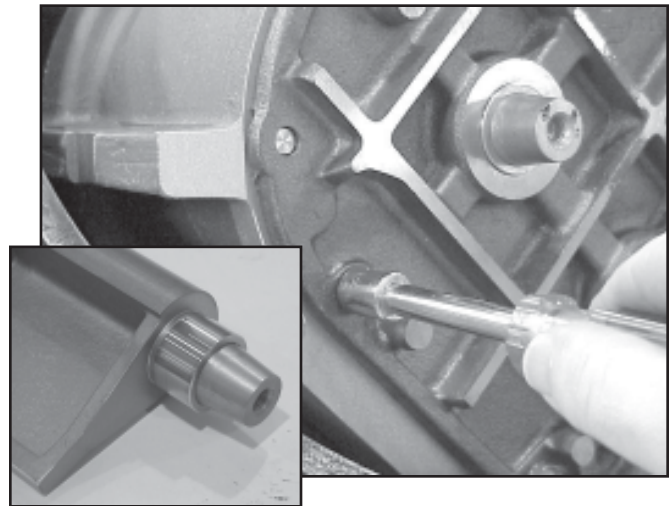

5. Install the rotor keys. The rotor key is a small wedge of metal. Position the keys in each one of the three rotors. Press the keys into the rotor keyways.

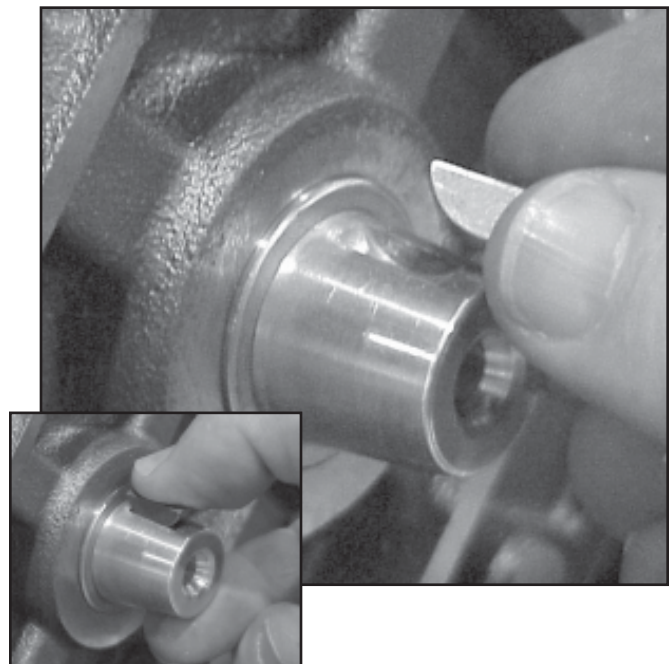

Rotor Gear Timing

- Slide the blocking rotor gear on its tapered rotor end. Slide the right displacement rotor gear on its tapered rotor end so that the timing marks line up between the two gears.

HINT: Before placing the right displacement rotor gear on its end, hold the right rotor gear in position. Turn the blocking rotor gear. Line up the timing marks before placing the right displacement rotor gear on its tapered end.

- Slide the left displacement rotor gear on its tapered rotor end so that its timing mark lines up with the blocking rotor gear.

- Insert the rotor gear screw and flat washer into each of the rotor gears and finger tighten.

- Position the spare displacement rotor gear between the left displacement rotor and the blocking rotor gear to prevent the gears from moving. If a replacement gear is not available, use a shop rag between the teeth of the gears. Tighten the screws of the displacement rotor gears to the torque specification listed in the Torque Chart.

- Position the spare displacement rotor gear between the right displacement rotor and the blocking rotor gear to prevent the gears from moving. Tighten the screw of the blocking rotor gear to the torque specification listed in the Torque Chart.

- Rotate the gears to make sure that the rotors turn freely. Burrs, foreign material, or marred surfaces can restrict the rotor movements. It may be necessary to remove the gears and rotors and deburr or clean the surfaces again.

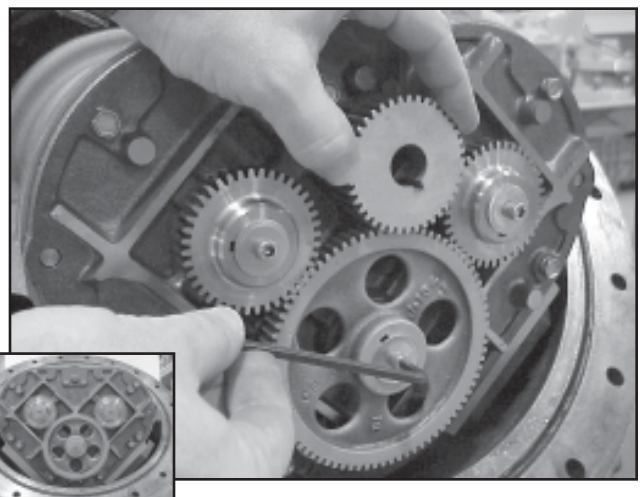
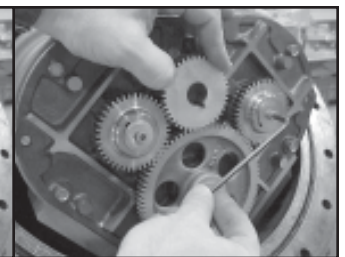
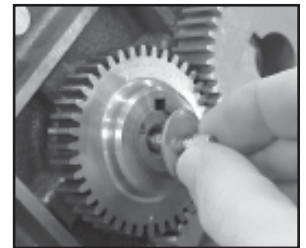
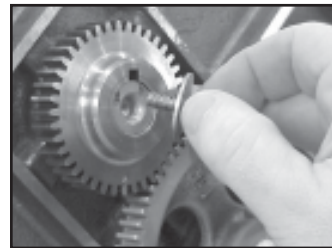
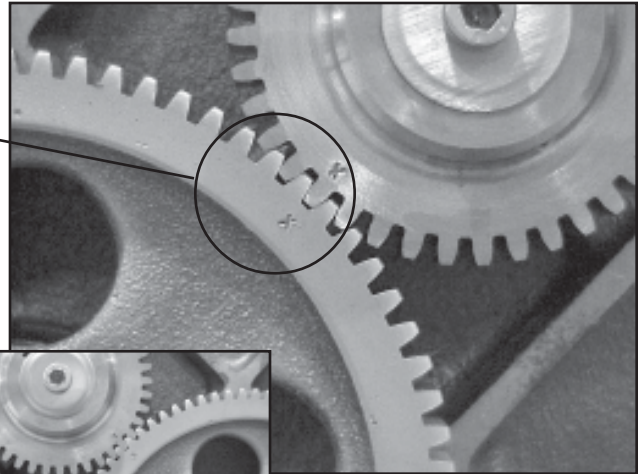

Reassembling the Meter

Reassembling the Weldment Assembly

12. Install a new O-Ring in the groove around the weldment base assembly if required.



13. Position the weldment cover on top of the weldment base so that the cover vent plug is on top.

Install the screws around the rim of the weldment cover. Attach the nuts to the back of each screw. Begin by hand-tightening each of the screws. Once this is complete, tighten the nuts and bolts to the proper torque following the tightening sequence on Page 31.

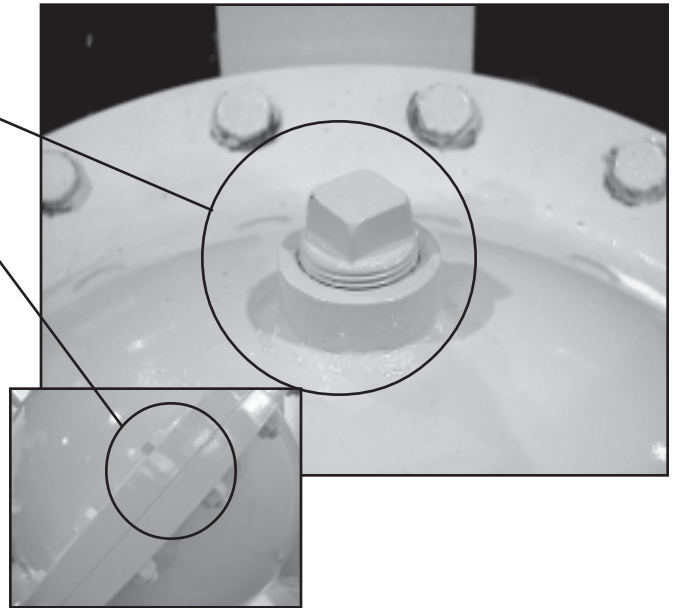

14. To complete the reassembly, reinstall the adjuster and drive components. When this is complete, reinstall the dust cover.

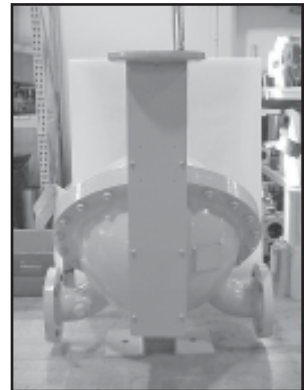

Wrench and Socket Size Chart

Bolt Tightening Sequence

When placing the weldment cover on the weldment base, it is important that the bolts are tightened in a sequence which reduces the risk of leaking when the system is put back in service. The number of bolts will vary depending on the size of the meter. The general pattern should be followed as pictured.

It is important to ensure that the O-Ring does not get pinched during this process.

Tighten the bolts following the pattern to 50% of the nominal torque. When all the bolts are torqued to 50%, they should then be torqued to the proper setting following the same pattern. Follow the torque specifications listed.

When replacing fastener elements, it is recommended to use compatible components.

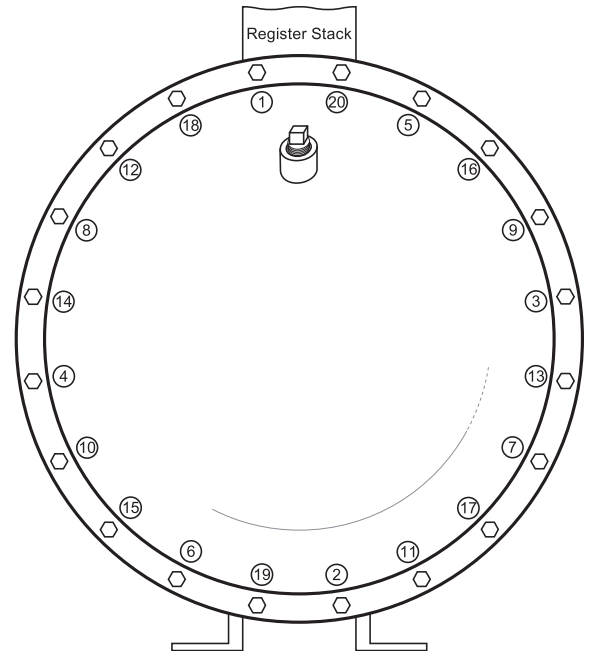

WRENCH/SOCKET USED								
Meter Model	Meter Element				Weldment Assembly			
	Dust Cover Screws	Counter Bracket Screws	Bearing Plate Screws	Rotor Gear Screws	Element Mounting Bolts	Drain Plug	Cover Vent Plug	Weldment Cover
MS-7 MSB-7	slotted screwdriver	1/4" Allen wrench	7/16" wrench/socket	3/8" wrench/socket	1/4" Allen wrench	13/16" 4-point socket	9/16 4-point socket	3/4" wrench/socket
MSA-7 MSAA-7	slotted screwdriver	1/4" Allen wrench	7/16" wrench/socket	3/8" wrench/socket	1/4" Allen wrench	13/16" 4-point socket	9/16 4-point socket	9/16" wrench/socket
MSC-7	slotted screwdriver	1/4" Allen wrench	7/16" wrench/socket	3/8" wrench/socket	1/4" Allen wrench	13/16" 4-point socket	9/16 4-point socket	15/16" wrench/socket
MS-15 MSA-15 MSAA-15	slotted screwdriver	1/4" Allen wrench	7/16" wrench/socket	3/16" Allen wrench	1/4" Allen wrench	13/16" 4-point socket	13/16" 4-point socket	9/16" wrench/socket
MSB-15 MSC-15	slotted screwdriver	1/4" Allen wrench	7/16" wrench/socket	3/16" Allen wrench	1/4" Allen wrench	13/16" 4-point socket	13/16" 4-point socket	1-5/16" wrench/socket
MS-30 MSA-30 MSAA-30 MS-40	slotted screwdriver	1/4" Allen wrench	7/16" wrench/socket	3/16" Allen wrench	9/16" wrench/socket	13/16" 4-point socket	13/16" 4-point socket	3/4" wrench/socket
MSB-30 MSC-30	slotted screwdriver	1/4" Allen wrench	7/16" wrench/socket	3/16" Allen wrench	9/16" wrench/socket	13/16" 4-point socket	13/16" 4-point socket	1-5/8" wrench/socket
MS-75 MSA-75 MSAA-75 MSB-75 MSC-75	slotted screwdriver	1/4" Allen wrench	1/2" wrench/socket	9/16" wrench/socket	15/16" wrench/socket	13/16" 4-point socket	13/16" 4-point socket	15/16" wrench/socket
MS-120 MSA-120 MSAA-120	slotted screwdriver	1/4" Allen wrench	1/2" wrench/socket	9/16" wrench/socket	15/16" wrench/socket	13/16" 4-point socket	13/16" 4-point socket	1-1/8" wrench/socket

Fastener and Torque Chart

FASTENERS USED								
Meter Model	Meter Element				Weldment Assembly			
	Dust Cover Screws	Counter Bracket Screws	Bearing Plate Screws	Rotor Gear Screws	Element Mounting Bolts	Drain Plug	Cover Vent Plug	Weldment Cover
MS-7 MSB-7	(6) #10-24 x .38 FLSTR HD SLOT.	(4) .312-18x1 HX. HD. SS.	(10) .250-20x.75 HX. HD. SS	(3) #10-24x.625 HX. HD. SS.	(4) .312-18x.75 HX. SCK. HD	(1) 1"-11.5 NPT SQ. HD.	(2) .500-14 NPT SQ. HD.	(12) .500-13x1.75 HX. HD. GR 5
MSA-7 MSAA-7	(6) #10-24 x .38 FLSTR HD SLOT.	(4) .312-18x1 HX. HD. SS.	(10) .250-20x.75 HX. HD. SS	(3) #10-24x.625 HX. HD. SS.	(4) .312-18x.75 HX. SCK. HD	(1) 1"-11.5 NPT SQ. HD.	(2) .500-14 NPT SQ. HD.	(16) .375-16x1.75 HX. HD. GR 5
MSC-7	(6) #10-24 x .38 FLSTR HD SLOT.	(4) .312-18x1 HX. HD. SS.	(10) .250-20x.75 HX. HD. SS	(3) #10-24x.625 HX. HD. SS.	(4) .312-18x.75 HX. SCK. HD	(1) 1"-11.5 NPT SQ. HD.	(2) .500-14 NPT SQ. HD.	(20) .625-11x2.5 HX. HD. GR 5
MS-15 MSA-15 MSAA-15	(6) #10-24 x .38 FLSTR HD SLOT.	(4) .312-18x1 HX. HD. SS.	(12) .250-20x.75 HX. HD. SS	(3) .250-20x.75 SCK. HD. SS	(4) .312-18x1.25 HX. SCK. HD.	(2) 1"-11.5 NPT SQ. HD.	(1) 1"-11.5 NPT SQ. HD.	(16) .375-11x2.5 HX. HD. GR 5
MSB-15 MSC-15	(6) #10-24 x .38 FLSTR HD SLOT.	(4) .312-18x1 HX. HD. SS.	(12) .250-20x.75 HX. HD. SS	(3) .250-20x.75 SCK. HD. SS	(4) .312-18x1.25 HX. SCK. HD.	(3) 1"-11.5 NPT SQ. HD.	(1) 1"-11.5 NPT SQ. HD.	(24) .875-9x5 HX. HD. GR 5
MS-30 MSA-30 MSAA-30 MS-40	(6) #10-24 x .38 FLSTR HD SLOT.	(4) .312-18x1 HX. HD. SS.	(16) .250-20x1 HX. HD. SS	(3) .250-20x.75 SCK. HD. SS	(4) .375-16x1.25 HX. HD. GR8	(3) 1"-11.5 NPT SQ. HD.	(1) 1"-11.5 NPT SQ. HD.	(20) .500-13x3 HX. HD. GR 8
MSB-30 MSC-30	(6) #10-24 x .38 FLSTR HD SLOT.	(4) .312-18x1 HX. HD. SS.	(16) .250-20x1 HX. HD. SS	(3) .250-20x.75 SCK. HD. SS	(4) .375-16x1.25 HX. HD. GR8	(3) 1"-11.5 NPT SQ. HD.	(1) 1"-11.5 NPT SQ. HD.	(28) 1"-8x7 GR B7 STUD
MS-75 MSA-75 MSAA-75 MSB-75 MSC-75	(6) #10-24 x .38 FLSTR HD SLOT.	(4) .312-18x1 HX. HD. SS.	(20) .312-18x1 HX. HD. SS	(3) .375-16x1.25 HX. HD. SS.	(4) .625-11x2.5 HX. HD. GR 5	(3) 1"-11.5 NPT SQ. HD.	(1) 1"-11.5 NPT SQ. HD.	(24) .625-11x4 HX. HD. GR5
MS-120 MSA-120 MSAA-120	(6) #10-24 x .38 FLSTR HD SLOT.	(4) .312-18x1 HX. HD. SS.	(20) .312-18x1 HX. HD. SS	(3) .375-16x1.25 HX. HD. SS.	(4) .625-11x2.5 HX. HD. GR 5	(3) 1"-11.5 NPT SQ. HD.	(1) 1"-11.5 NPT SQ. HD.	(24) .750-10x3 HX. HD. GR 5

Torque Chart

Torque Ref. #	Bolt Size	Inch-Pounds	Newton-Meter
		NOMINAL*	NOMINAL*
1	#8 (.164) - 32 UNC-2A	42	4.8
2	#10 (.190) - 24 UNC-2A	63	7.1

NOTE: ASTM A574 socket Head Cap Screw - Low Alloy Steel: quenched & tempered.

Torque Ref. #	Bolt Size	Grade 5		Grade 8	
		Foot-Pounds	Newton-Meter	Foot-Pounds	Newton-Meter
		NOMINAL*	NOMINAL*	NOMINAL*	NOMINAL*
3	1/4" (.250) - 20 UNC-2A	7.3	9.9	---	---
4	5/16" (.3125) - 18 UNC-2A	15.3	20.7	---	---
5	3/8" (.375) - 16 UNC-2A	27	37	---	---
6	7/16" (.4375) - 14 UNC-2A	43	58	---	---
7	1/2" (.500) - 13 UNC-2A	66	90	112	152
8	5/8" (.625) - 11 UNC-2A	132	179	222	301
9	3/4" (.750) - 10 UNC-2A	233	316	395	535

*Torque Tolerance is $\pm 10\%$

Identification of Bolt Grades

Grade 0, 1, & 2
(No Markings)



Grade 6
4 radial dashes, 90° apart



Grade 3
2 radial dashes, 180° apart



Grade 7
5 radial dashes, 72° apart



Grade 5
3 radial dashes, 120° apart



Grade 8
6 radial dashes, 60° apart

Troubleshooting

Problem: Leakage past the packing gland drive shaft housing from internal metering chamber.

Probable Cause: Internal seal of the packing gland assembly is worn. Replace packing gland and O-Ring seal.

Operating Note: Two common causes of packing gland leakage are thermal expansion and hydraulic shock. If two valves in a piping system (on either side of the meter) are closed at one time, and if the temperature rises as little as 1°F in the system, it could result in a rise in pressure (70 psi for every 1°F) within the system that would exceed the working pressure rating of the meter. To avoid this hazard caused by thermal expansion, a pressure-relief valve must be installed in the system. Hydraulic shock occurs when a large volume (mass) of liquid is moving through a pipe line at some flow rate and a valve is suddenly closed. When the flow is stopped, the entire mass of liquid in the piping system acts as a battering ram causing a shock effect within the meter. The greater the mass, length of line, and/or velocity, the greater the hydraulic shock. Since the valve is usually located at the meter outlet, the meter housing, packing gland and the meter internal components receive the full impact of such hydraulic shock. To prevent this hazard, a slow closing, two-stage valve should be used with the meter. On those systems where mass length of line, etc. are of such magnitude as to preclude elimination of hydraulic shock with the use of a two-stage valve, an impact absorbing or cushioning device should be used.

Problem: Leakage from the cover gasket.

Probable Cause: Gasket has been damaged due to shock pressure, thermal expansion, or cover bolts that have not been sufficiently tightened.

Problem: Breaking teeth on rotor timing gears.

Probable Cause:

1. Starting or stopping flow in the meter too rapidly.
2. Pump bypass not adjusted properly.
3. Shock due to start-up of an empty system. When liquid is introduced, shock can occur if not started slowly.

Troubleshooting

Problem: Product flows through the meter but the register does not operate.

Probable Cause:

1. Check the packing gland and gear train.
 2. If all meter parts are moving, the problem is in the register. Faulty registers should be checked and repaired by a trained technician.
 3. Remove the register from the meter. If all meter parts are moving but the output of adjuster assembly is not, adjuster is worn and must be replaced.
 4. If totalizer numbers (small numbers) on the meter are recording, but the large numbers are not moving, the register needs repair.
 5. The packing gland gear is not turning. The drive blade may be sheared. Replace the packing gland. This may be caused by starting the flow too rapidly.
-

Problem: Product flows through meter but register does not record correctly.

Probable Cause:

1. Adjuster not properly calibrated.
 2. Incorrect gear plate or gear ratio has been installed.
 3. Meter is damaged.
 4. There is air in the system
-

Problem: No flow through meter.

Probable Cause:

1. Faulty pump.
 2. Valve not open or not functioning.
 3. Meter “frozen” due to buildup of chemical “salts” or foreign material inside the metering chamber. To correct, clean the meter and inspect for damage.
-

Problem: Meter runs too slowly.

Probable Cause:

1. Valve internal mechanism faulty. Valve does not open fully.
 2. Meter gears or rotors partially “salted” enough to slow up rotation of parts. To correct, clean the meter.
 3. The strainer basket is partially clogged.
-

Problem: The meter counts down (the numbers decrease).

Probable Cause: It is necessary to reverse the direction of flow by reversing the adjuster drive gear. See Meter Start Up & Operation on Page 12 of this manual.

How to Order Replacement Parts

1. Refer to the exploded drawings of the meter on Pages 36-39. Find the four digit item number for the part you want to order.
2. Find the computer printout titled Bill of Materials that has been inserted in the red Owner's Information Packet. Look up the item number on the Bill of Materials. The Bill of Materials shows each item number with a corresponding part number. Find the corresponding part number for the item you want to order. The part number represents an individual piece, a kit, or a complete assembly.
3. Inform your distributor of the part number that you need. The part number is the only number that allows the distributor to find the correct component for your meter.

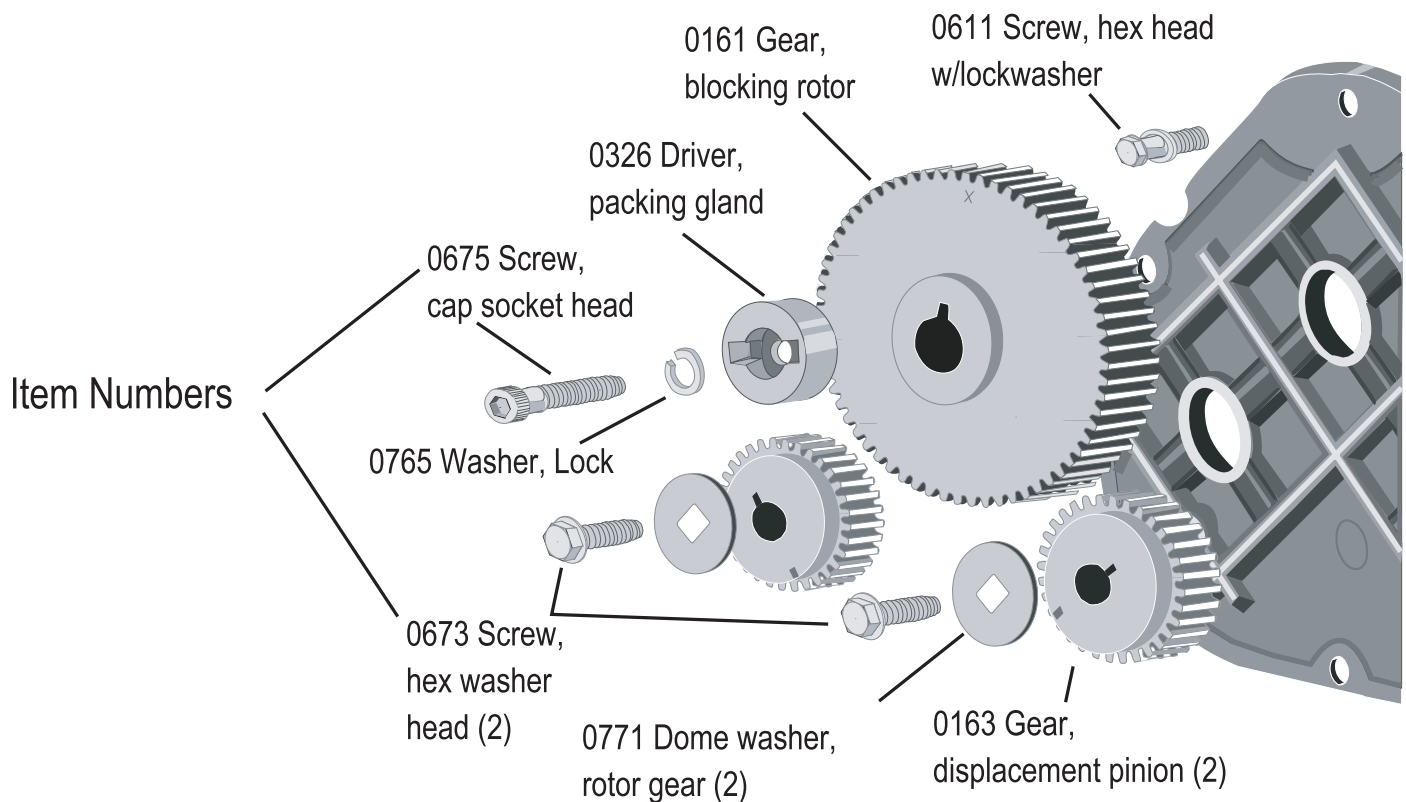

Illustrated Parts Breakdown

Adjuster Housing Assembly

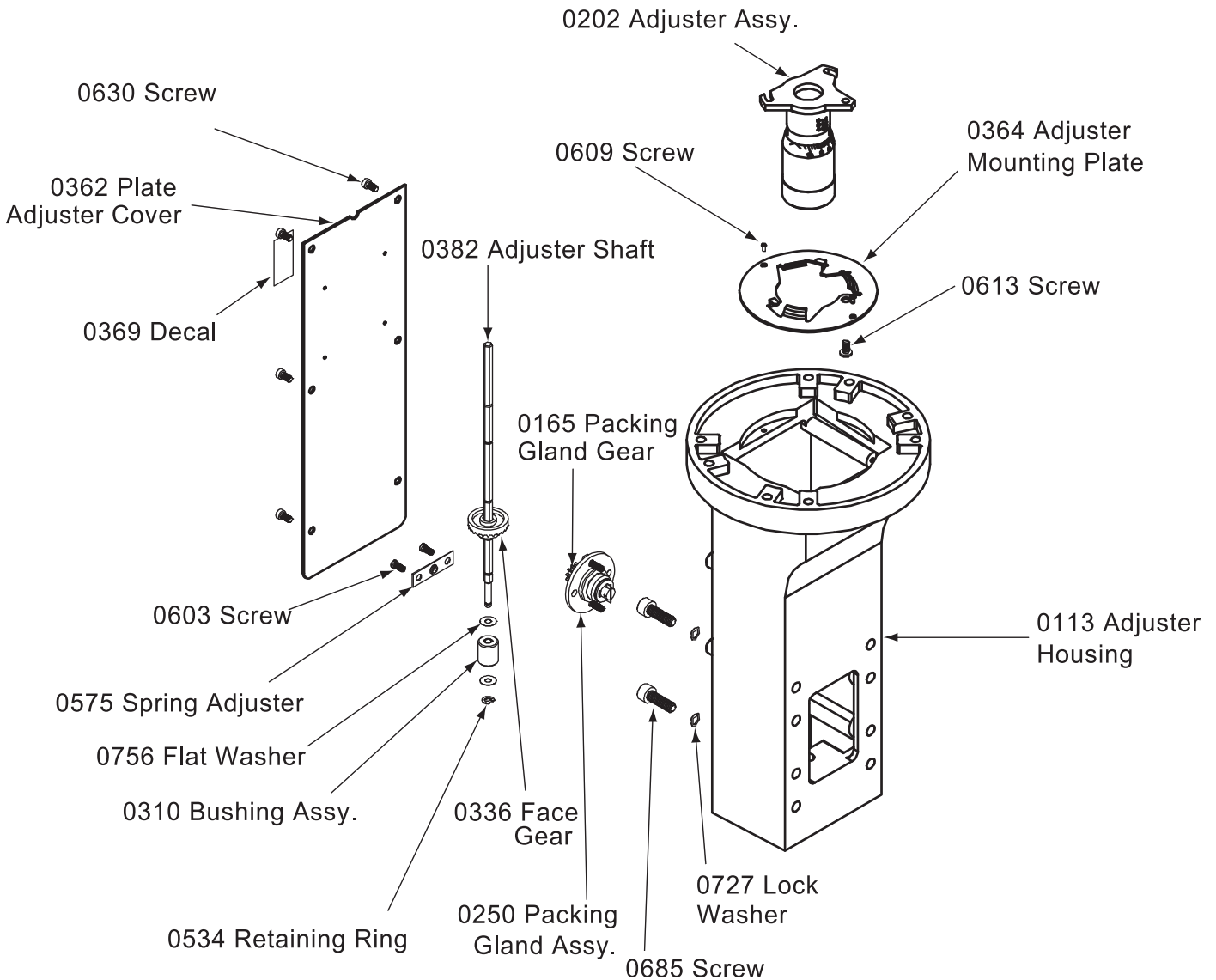

NOTE: Numbers shown are **ITEM** numbers, not Part Numbers. Refer to the Bill of Materials supplied in the red Owner's Information Packet to locate the **PART NUMBER** associated with these **ITEM NUMBERS**.

Weldment Assembly

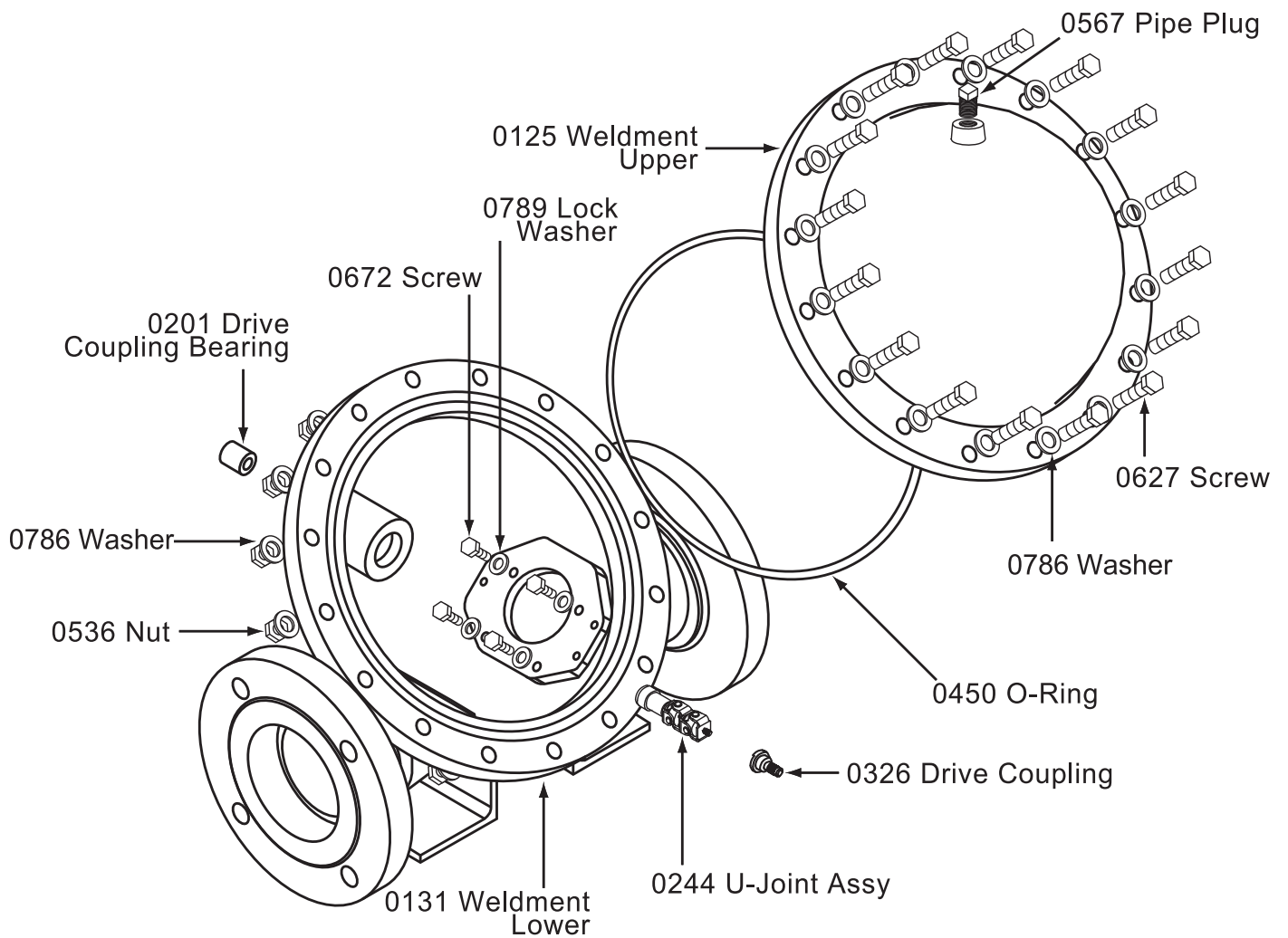

NOTE: Numbers shown are **ITEM** numbers, not Part Numbers. Refer to the Bill of Materials supplied in the red Owner's Information Packet to locate the **PART NUMBER** associated with these **ITEM NUMBERS**.

Illustrated Parts Breakdown

Meter Element Assembly

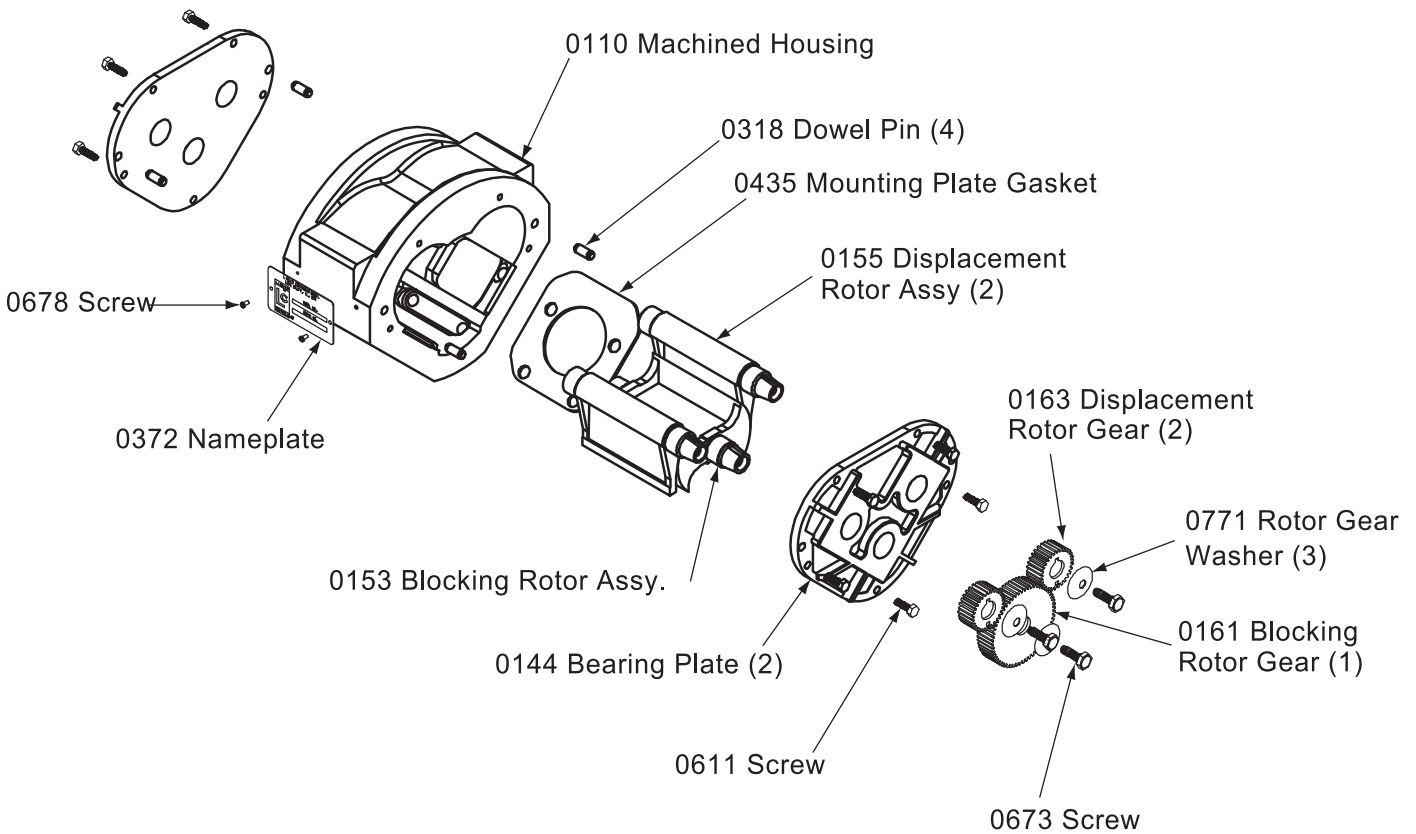

NOTE: Numbers shown are **ITEM** numbers, not Part Numbers. Refer to the Bill of Materials supplied in the red Owner's Information Packet to locate the **PART NUMBER** associated with these **ITEM NUMBERS**.

Complete Assembly

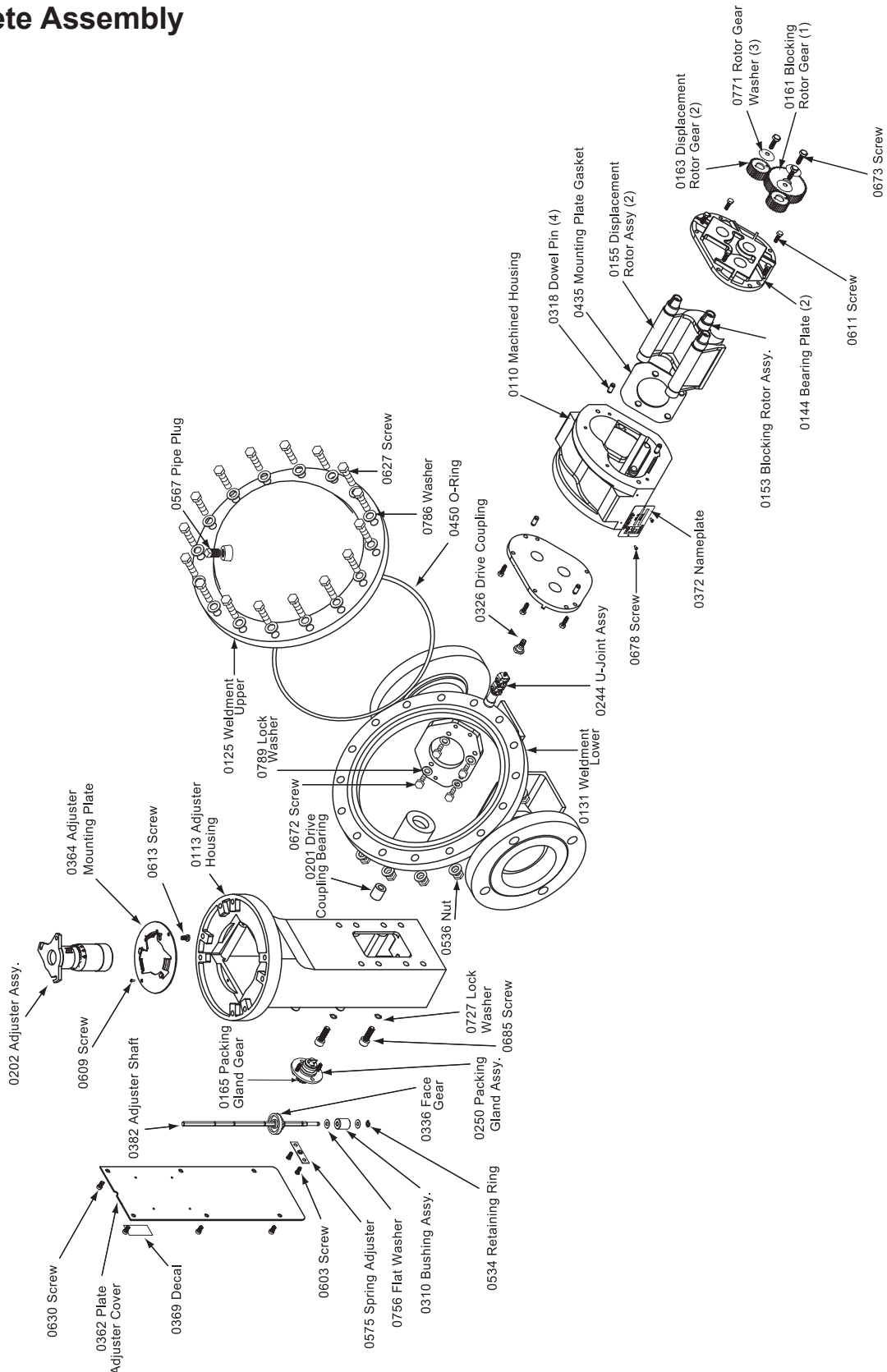

NOTE: Numbers shown are **ITEM** numbers, not Part Numbers. Refer to the Bill of Materials supplied in the red Owner's Information Packet to locate the **PART NUMBER** associated with these **ITEM NUMBERS**.

LIQUID CONTROLS GROUP **IDEX** LIQUID CONTROLS GROUP **CORKEN · FAURE HERMAN · LIQUID CONTROLS · SAMPI · SPONSLER · TOPTECH SYSTEMS**

LIQUID CONTROLS

105 Albrecht Drive
Lake Bluff, IL 60044
(847) 2951050

SAMPI

Via Amerigo Vespucci 1
55011 Altopascio (Lucca), Italy
+39 (0) 583 247600

LIQUID CONTROLS INDIA

Survey No. 256, Alindra
Savli GIDC, Manjusar
Dist. Vadodara 391 770
Gujarat, India
+91 265 2631855

TOPTECH SYSTEMS

1124 Florida Central Parkway
Longwood, FL 32750
(407) 332-1774

Nateus Business Park
Nieuwe Weg 1-Haven 1053
B-2070 Zwijndrecht (Antwerp), Belgium
+32 (0)3 250 60 60

FAURE HERMAN

Route de Bonnetable
B.P. 20154
72406 La Ferté-Bernard Cedex, France
+33 (0) 243 0602860

6961 Brookhollow West Drive
Houston, TX 77040
(713) 623-0808

CORKEN

3805 Northwest 36th St.
Oklahoma City, OK 73112
(405) 946-5576



LIQUID CONTROLS

A Unit of IDEX Corporation
105 Albrecht Drive
Lake Bluff, IL 60044-2242
1.800.458.5262 • 847.295.1050
Fax: 847.295.1057
www.lcmeter.com

© 2006 Liquid Controls
Pub. No. 500318
(4/13)

