



(केवल कार्यालय प्रयोग हेतु)
(For official use only)

(भारत सरकार/Govt. of India)
(रेल मंत्रालय/Ministry of Railways)

माल वाहनों की ट्रेन पार्टिंग पर हस्तपुस्तिका
(कारण एवं निवारण)
HAND BOOK
ON
TRAIN PARTING
OF
FREIGHT STOCK
(CAUSES AND REMEDIES)



केमटेक / 2011-12/एम/ट्रेन पार्टिंग/1.0
CAMTECH/ 2011-12/M/Train Parting/1.0

अगस्त-2011 /August - 2011

अअमा सं RDS
रेल अग्रदूत Transforming Railways



Indian Railways
Centre for Advanced Maintenance Technology
Maharajpur, Gwalior – 474 005

महाराजपुर, ग्वालियर – 474005

**माल वाहनों की ट्रेन पार्टिंग
पर हस्तपुस्तिका
(कारण एवं निदान)**

**TRAIN PARTING
OF FREIGHT STOCK
(CAUSES AND REMEDIES)**

प्राक्कथन

माल वाहकों में बिना किसी उद्देश्य के होने वाली ट्रेन विभाजन का परिचालन एवं सुरक्षा पर गंभीर प्रभाव होता है। ट्रेन विभाजन के विश्लेषण से यह ज्ञात होता है कि मुख्यतः सी.बी.सी. अवयवों के टूटने या घिसने से गाड़ी के परीक्षण एवं मरम्मत के दौरान उचित ध्यान न देने से कमजोर इंजिनमेनशिप तथा अन्य परिचालन कारणों से ट्रेन विभाजन होता है।

इस हस्तपुस्तिका में उपरोक्त सभी विषयों को संक्षिप्त एवं उचित ढंग से शामिल किया गया है। आवश्यकतानुसार चित्र एवं रंगीन फोटों साफ समझने के लिए दिये गये हैं।

मैं आश्वस्त हूँ कि यह हस्तपुस्तिका ट्रेन परिचालन के दौरान ट्रेन पार्टिंग के प्रकरणों को समझने, समस्या रहित सेवा प्रदान करने में संबंधित कर्मचारियों के लिए उपयोगी सिद्ध होगी।

दिनांक : 03.08.2011
केमटेक ग्वालियर

(एस.सी. सिंघल)
कार्यकारी निदेशक

FOREWORD

Unintentional train partings of freight stock have serious repercussions on operation and safety. From the analysis of cases of train partings, it is observed that train partings takes place mainly due to breakage / wear of CBC components, improper attention during examination and maintenance, poor engineman ship and few operational reasons.

This hand book have covered all the above topics in a brief and lucid manner. Wherever required sketches and coloured photographs have been provided to make the understanding clear.

I am sure that the handbook will be useful to the concerned staff to ensure trouble free service of the train operation by minimizing the cases of train partings.

CAMTECH, Gwalior
Date: 03.08.2011

S.C. Singhal
Executive Director

भूमिका

रेल्वे बोर्ड ने केमटेक को मालगाड़ियों के ट्रेन पार्टिंग पर कैंरिज एवं वैगन कर्मचारियों एवं रनिंग सी.बी.सी. अवयवों के कर्मचारियों के लिए परिचालन दक्षता, निरीक्षण, ट्रेक एवं परीक्षण एवं अनुरक्षण के दौरान विभिन्न कदमों को अपनाने हेतु एक हस्तपुस्तिका तैयार करने को कहा। उसी तारतम्य में यह हस्तपुस्तिका तैयार की गयी है।

इस हस्तपुस्तिका का उद्देश्य भारतीय रेल के कर्मचारियों के लिए जो कि मालवाहक ट्रेनों के परिचालन एवं परीक्षण में संलग्न हैं, के लिए औजार प्रदान करता है। ताकि ट्रेन पार्टिंग के प्रकरणों में कमी करने एवं सुरक्षा एवं परिचालन में गुणवत्ता आ सकें।

इस हस्तपुस्तिका का उद्देश्य सम्बंधित कर्मचारियों को सहायता प्रदान करता है न कि रेल्वे बोर्ड आर.डी.एस.ओ. अथवा आई.आर.सी.ए. आदि के निर्देशों को सुपरसीड करना। अधिकांश डाटा एवं जानकारी जो यहाँ दी गई है वह कहीं न कहीं विभिन्न पुस्तकों एवं मैनुयुल्स या प्रिंटेड सामग्री में उपलब्ध है। यदि इस पुस्तिका में कोई सुधार किया जाता है तो वह सुधार पत्र के रूप में होगा। सुविधा की दृष्टि से इस पुस्तिका में एक प्रोफार्मा सुधार पत्रों को क्रमशः शामिल करने के लिये दिया गया है।

हम अपने पाठकों से किसी भी सुधार एवं जोड़ने हेतु दिये जाने वाले सुझावों का स्वागत करते हैं।

दिनांक : 03.08.2011
केमटेक ग्वालियर

(के.पी.यादव)
निदेशक/यांत्रिक

PREFACE

In order to minimize train parting cases on Indian Railways, Railway board instructed CAMTECH to prepare a handbook for carriage & wagon staff and running staff on Train Parting of freight stock covering tips on driving skill, inspection and measurement of CBC components and various steps to be taken during examination and maintenance of freight stock. Accordingly this handbook has been prepared giving all above. Coloured photographs have been provided to clarify the concept.

The objective of this book is to provide a tool to the staff involved in examination and operation of freight trains to reduce cases of train partings thereby improving safety and throughput of Indian Railways.

This hand book is aimed at assisting concerned staff and does not supersede any existing instructions from Railway Board, R.D.S.O. or IRCA etc. Most of data and information mentioned here in are available in some form the other in various books and manuals or other printed matter. If any changes are made, these will be used in the form of correction slips. For convenience, this book includes a proforma for entering all correction slips serially.

We welcome any suggestion for addition and improvements from our readers.

CAMTECH, Gwalior
Date: 03.08.2011

(K.P. Yadav)
Director, Mechanical

विषय सूची

क्र.स.	विवरण	पृष्ठ संख्या
	प्राक्कथन	i
	भूमिका	ii
	विषय सूची	iii
	संशोधन पर्ची	iv
1.0	परिचय	1
1.1	ट्रेन पार्टिंग	1
1.2	ट्रेन पार्टिंग के प्रकार	1
2.0	सी.बी.सी. का खुलना	3
2.1	ट्रेन पार्टिंग के अति महत्वपूर्ण कारण	3
2.2	माल वाहनों के सी.बी.सी. के खुलने से बचाने के लिए दिशा निर्देश	4
3.0	सी.बी.सी. अवयवों का टूटना/घिसाव	13
3.1	सी.बी.सी. अवयवों का विवरण	13
3.2	मापक यंत्र एवं उनका प्रयोग	25
	गार्ड आर्म एक्सपेन्शन की जाँच	27
	गार्ड आर्म डिस्टोर्सन की जाँच	28
	स्ट्रेचड नक्कल की जाँच	29
	नक्कल नोच के टूटने की जाँच	30
	नक्कल लॉकिंग फेस की जाँच	31
	बॉटम फिल्टर की एन्टीक्रीप लेप की जाँच	32
	रोटरी लीवर के एन्टीक्रीप लग की जाँच	33
	लॉक वियर की जाँच	34
3.3	सेन्टर बफर कपलर एवं ड्रापट गियर की शक्ति	35
3.4	माल वाहन के ड्रापट गियर एवं बर्किंग गियर के प्रकार	35
3.5	सी.बी.सी. की कार्यप्रणाली	35
3.6	नक्कल का टूटना	36
3.7	वैगन के सी.बी.सी. अवयवों की मानक माप	37
4.0	इंजिनमेशनशिप	39
4.1	त्रुटिपूर्ण	39

क्र.स.	विवरण	पृष्ठ संख्या
	इंजिनमेनशिप	
4.2	ट्रेन पार्टिंग से बचने के उपाय	39
4.3	जर्क से बचने के उपाय	41
5.0	आर.ओ.एच. एवं पी.ओ.एच. में गाड़ी के परीक्षण के दौरान सावधानियाँ	44
5.1	यार्ड में गाड़ी के परीक्षण के समय सावधानी	44
5.2	आर.ओ.एच. के दौरान सावधानी	45
5.3	पी.ओ.एच. के दौरान सावधानी	46
5.4	परिचालन एवं यार्ड कर्मचारियों के लिए सावधानी	48
6.0	चैक लिस्ट	50
6.1	ट्रेन पार्टिंग की संयुक्त अन्वेषण के लिए चैक लिस्ट	50
6.2	प्रभावित वैगन के लिए चैक लिस्ट	52
6.3	सी.बी.सी. खुलने के अन्वेषण के लिए चैक लिस्ट	56

CONTENTS

SNo.	Description	Page No.
	Forward	i
	Preface	ii
	Contents	iii
	Correction slips	iv
1.0	Introduction	1
1.1	Train parting	1
1.2	Types of train parting	1
2.0	Uncoupling of CBCs	3
2.1	Most Common causes of Train Parting	3
2.2	Guidelines for preventing CBC uncoupling in Freight stock	4
3.0	Breakage /wear of CBC components	13
3.1	Description of CBC Components	13
3.2	Measuring Gauges & Their Applications	25
	Checking of guard arm expansion	27
	Checking of guard arm distortion	28
	Checking of stretched knuckle	29
	Checking of knuckle nose wear	30
	Checking of knuckle locking face	31
	Checking of anti-creep ledge of bottom lifter	32
	Checking of anti-creep lug of rotary lever	33
	Checking of lock wear	34
3.3	Strength of Centre Buffer Coupler & Draft Gear	35
3.4	Types of Draft and Buffing Gears on Freight Stock	35
3.5	Working of CBC	35
3.6	Breakage of Knuckle	36
3.7	Standard Dimensions for CBC Items of Wagons	37
4.0	Engineman Ship	39

SNo.	Description	Page No.
4.1	Poor engineman Ship	39
4.2	Measures to avoid train parting	39
4.3	Measures to avoid jerks.	41
5.0	Attention during Train Examination. ROH & POH	44
5.1	Attention during yard Examination	44
5.2	Attention during ROH	45
5.3	Attention during POH	46
5.4	Attention by Operating and Yard Staff	48
6.0	Check List	50
6.1	Check List for Joint Investigation Report of Train Parting	50
6.2	Check List for Affected Wagons	52
6.3	Check List for Investigation of CBC Uncoupling	56

अध्याय /Chapter-1.0

परिचय/INTRODUCTION

1.1 ट्रेन पार्टिंग /What is Train Parting?

Train parting is unforeseen division of a train into two or more portions while the train is on run or just about to move. Train Parting is a common unusual occurrence affecting train movement adversely. Freight train operation by crew and maintenance of wagons are the two major activities involved in train parting. There are many contributing factors towards train parting such as inadequate maintenance, material failure, improper driving & improper marshalling etc.

1.2 ट्रेन पार्टिंग के प्रकार /Types of Train Parting and their causes

Train parting is classified under two main heads.

1.2.1 Vertical Parting:- Vertical parting takes place due to excessive CBC height variation. The main reasons for variation in CBC height are;

- a. Loose/ low rail joints
- b. Mud pumping under the rail joints
- c. CBC drooping– excessive wear and tear of coupler shanks and striker casting/ bearing piece.
- d. Excessive over loading in the wagons.

1.2.2 Horizontal Parting :- Horizontal train parting takes place due to following reasons:

- a. Uncoupling of CBC.
- b. Breakage/ wear of CBC components due to inherent defects.
- c. Failure of draft gear.

d. Bad engineman ship

The details of these causes and remedial measures to be taken to arrest train partings have been discussed in subsequent chapters

अध्याय /Chapter-2.0

सी.बी.सी. का खुलना /UNCOUPLING OF CBC

As explained earlier in chapter 1 the train partings can be either uncoupling or breakage of components. While details of uncoupling cases are described in chapter 3, the train partings due to breakage of CBC components is described in this chapter.

The breakage of CBC components can be either due to inherent manufacturing fault, wear of components or poor engineman ship leading to jerks.

The details of poor engineman ship and the remedial measures to be taken have been described in chapter 4.

The causes and remedial measures to be taken for breakage of CBC components either due to inherent manufacturing faults or wear are described in this chapter.

2.1 ट्रेन पार्टिंग के अति महत्वपूर्ण कारण

The most common causes of train parting are, uncoupling of CBC on run (without any breakage of any parts), breakage of knuckle failure of draft gear and working out of CBC. The reasons of uncoupling and preventive measures taken to avoid uncoupling are described as under -

- i) **Lock not properly engaged** – In most of the cases, the lock does not drop down to the full locked position inside the coupler head. This may result in slipping up of the lock during run causing uncoupling.
- ii) **Ineffective anti-creep device** – Lock may slip up due to jerking and jolting during run if the anti creep feature is not effective.
- iii) **Operating handle dropping on run** - This is caused by breakage of supporting bracket resulting in operating handle

- falling down on run and hitting the ballast. This tends to turn the handle leading to lifting of the lock piece and uncoupling.
- iv) **Excessive play between anti-rotation lug and bearing piece slot** : Due to excessive play between anti-rotation lug and bearing piece slot, operating handle can operate on run due to jerks and can cause uncoupling. Anti rotation lug is made out of square cross section MS bar with standard dimensions of 16 mm x 16 mm and slot width in bearing piece of 17.5 mm.
 - v) **Unauthorized tempering with operating handle** – This is believed to be a common incidence by many Railways. Since, uncoupling lever is situated alongside the wagon and is easily accessible, it is easily prone to unauthorized and mischievous manipulation.
 - vi) **Uncoupling due to vertical slipping out of knuckle** - This may occur due to abnormal relative vertical movement between the two coupler heads causing slippage of one knuckle out of the other. This situation is very unlikely to arise but there may be a possibility in the event of combination of number of adverse factors like maximum difference in coupler heights & unevenness on rail joints.

2.2 माल वाहनों के सी.बी.सी. के खुलने से बचाने के लिए दिशा निर्देश /Guidelines for preventing CBC uncoupling in Freight Stock.

The cases of uncoupling of freight trains on the Railways have increased. On thorough analysis, it came to light that required attention is not being paid during ROH and Yard examinations. It is also observed that, the knowledge of the technicians is not sufficient. It is therefore necessary to impart training to technicians on the subject matter in the C&W BTCs. The following guidelines with pictorials of the defective parts of CBCs are given for ready references:-

2.2.1 Operating Handle :

- (i) The correct geometry of the operating handle is very essential. The operating handle should not be bent. The photograph of proper and improper(bent) operating handle is given as under.

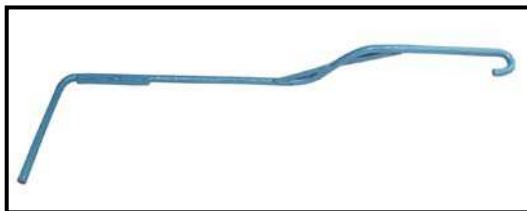

Standard operating handle

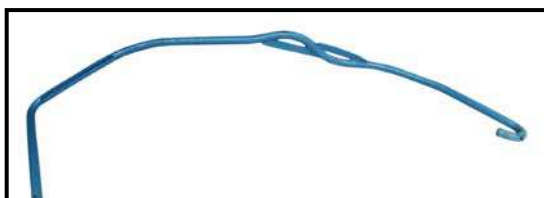

Bent operating handle

- (ii) The length of the operating handle are different for different types of wagons. The length of the operating handle wagon wise are given as under.

S.No.	Type of wagon	Standard length in MM
1	BOXN/BCN	1414
2	BLCA/BLCB	1063
3.	BTPN	1414
4	BVZI	1414
5	BVZC	1450

2.2.2 Anti Rotation Lug:

- (i) There should be no excessive wear in **Anti rotation lug**. The lug length and all the dimensions of the lugs are very

important as there should not be any excessive play between the bearing piece and anti rotation lug. The standard section of the anti rotation lug is **16 mm x 16 mm**.

- (ii) The circular section on anti rotation lug should not be permitted at all. The operating handle provided with the photograph of operating handle with circular section lug is given as under.

Photograph of new rotation lug

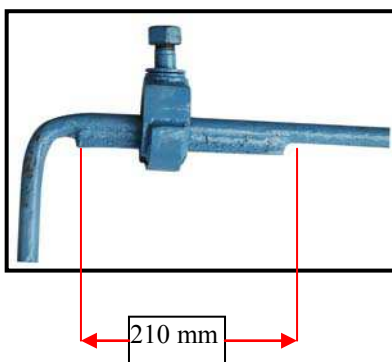

Photograph of circular section of rotation lug

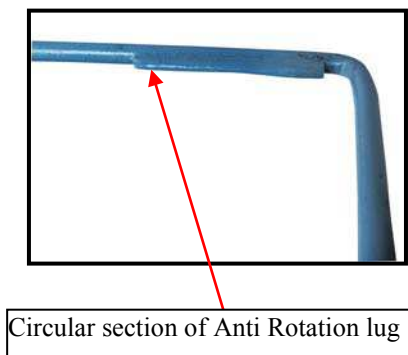

2.2.3 Bearing Piece Slot:

- (i) There should not be any excessive wear in the **bearing piece** slot. The standard width of the slot is 17.5 mm. The photographs of the bearing pieces with standard slot width and worn out width are given as under.
- (ii) The bearing piece pin should be properly welded to hanger bracket. The photograph of the correctly welded bearing pin is given as under.

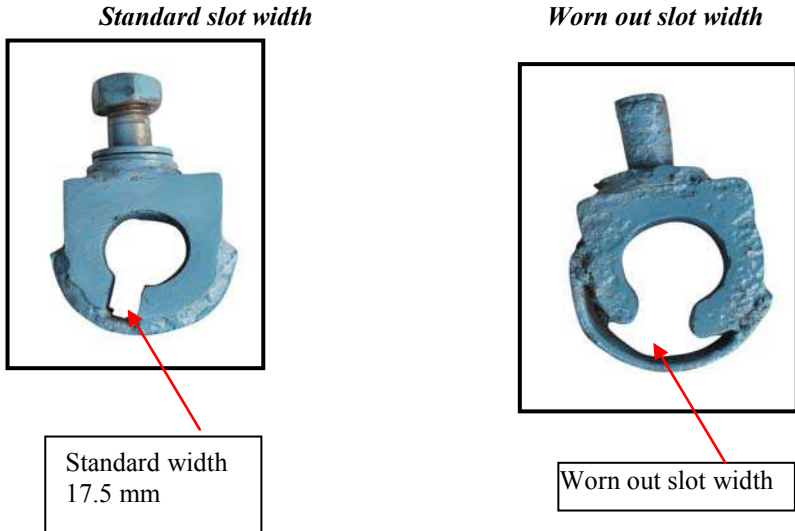

2.2.4 Articulated Lock Lift Assembly:

- (i) The components of Lock Lift Assembly such as **toggle**, **lever connector** and **lever hook** should be properly riveted. The photograph of Lock Lift Assembly is given as under.

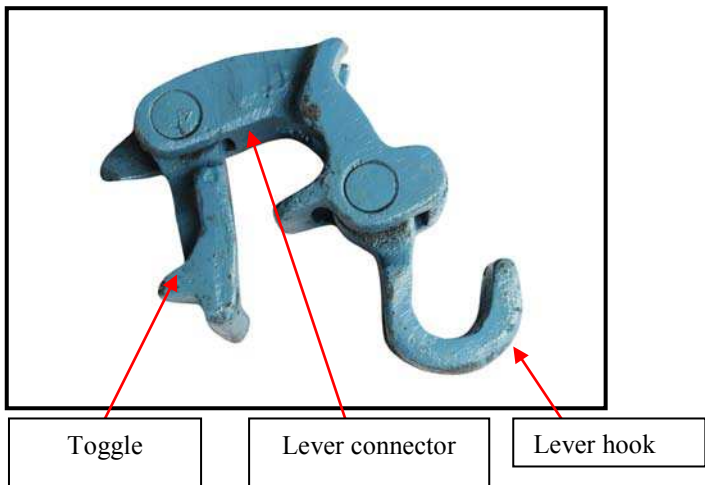

- (ii) Ensure that anti creep lug of the lever connector is not excessively worn out. There is no gauge specified for measuring the wear. However it should be checked with worn sample which can serve as a comparator.

Auxiliary anti creep lug



Anti creep lug

Worn out sample of anti creep



Worn out Anti creep lug

- (iii) The distance between the bottom of the CBC head and auxiliary anti creep lug should not be excessive. The standard distance is not less than 19 mm.

Distance between the bottom of the CBC head and auxiliary anti creep lug



19 mm

2.2.5. Knuckles

- (i) Ensure that the knuckles are not excessively worn out. The knuckle should be checked with contour gauge No.3. There is no gauge specified for measuring the surface wear in the location of CBC Lock seating area. The standard width at the tip is 18 mm. If the wear is more than 8.5 mm, knuckle should be rejected. The knuckle pin should be secured properly from both top and bottom by welding APD. The photograph of correctly secured knuckle pin is given as under.

(ii) *Standard width 18MM & wear limit 9.00 mm at tip*



Nose of knuckle 18 mm when new

Use of knuckle stretch gauge



Knuckle Nose Wear –
Limit: 9.5 mm for Replacement

Photograph of correctly secured knuckle pin



Knuckle pin
secured correctly

Knuckle pin should be standard and straight. Non-standard and bent knuckle pin

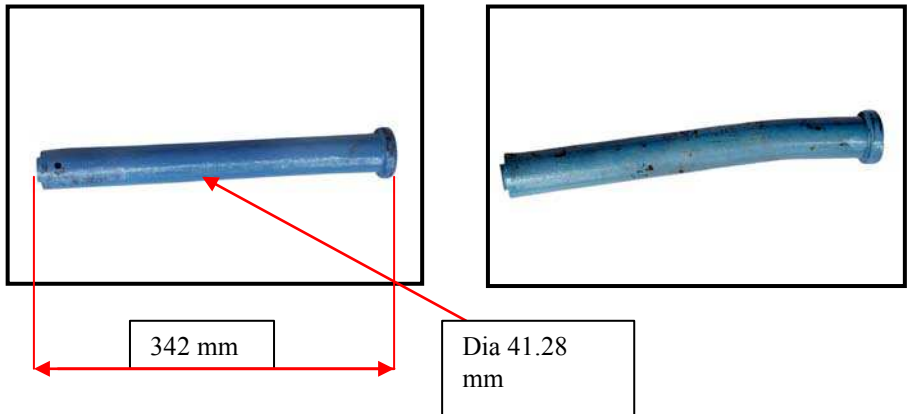

2.2.6. CBC Lock

- (i) Most of the uncoupling cases are taking place because of the worn out lock piece. The wears are taking place on the side walls, mating walls of the coupler body and bottom surface mating with the knuckles. The checking of the wears should be done with standard gauge. However, worn out lock should be kept as a comparator for ready reference for rejecting the material.

View of new knuckle face & lock piece



Gauging of knuckle face with the help of Gauge No. 3



2.2.7. Coupler Body

- (i) The Guard arm expansion should be checked with contour gauge No. 1 & 2 (Go-No-go gauge).
- (ii) The photograph of measuring guard arm contour is given as under-

Correct method of gauging



Wrong practice of gauging



- (iii). The condition of the shank wear plate should be checked. The wear should not be more than 5 mm., new thickness is 6 mm.

View of new shank wear plate



Condemning limit of shank wear plate



(iv). Variation between the CBC heights of adjacent wagons should be within the permissible limit of **75 mm**.



CBC height variation not more than 75 mm

It is suggested that the above physical measurement exercise may be incorporated in the mandatory & refresher training courses being organized for technicians at C&W Basic Training Centres.

अध्याय /Chapter 3.0

सी.बी.सी. अवयवों का टूटना / घिसाव

BREAKAGE / WEAR OF CBC COMPONENTS

Centre buffer couplers are adopted for use on Indian Railways are knuckle type similar to American Railroads. Indian Railway uses AAR type centre buffer couplers having E-type head and F-type shank for freight stock on Broad gauge system. These couplers are generally as per requirements of AAR Specifications M-201.

3.1 सी.बी.सी. अवयवों का विवरण /Description of CBC Components

The various components of CBC are as under –

- i) **Coupler Body**
- ii) **Yoke**
- iii) **Draft Gear**
- iv) **Knuckle**
- v) **Knuckle pin**
- vi) **Striker casting plate**
- vii) **Shank wear plate**
- viii) **Yoke pin**
- ix) **Locking Arrangements**
- x) **Operating Mechanism**

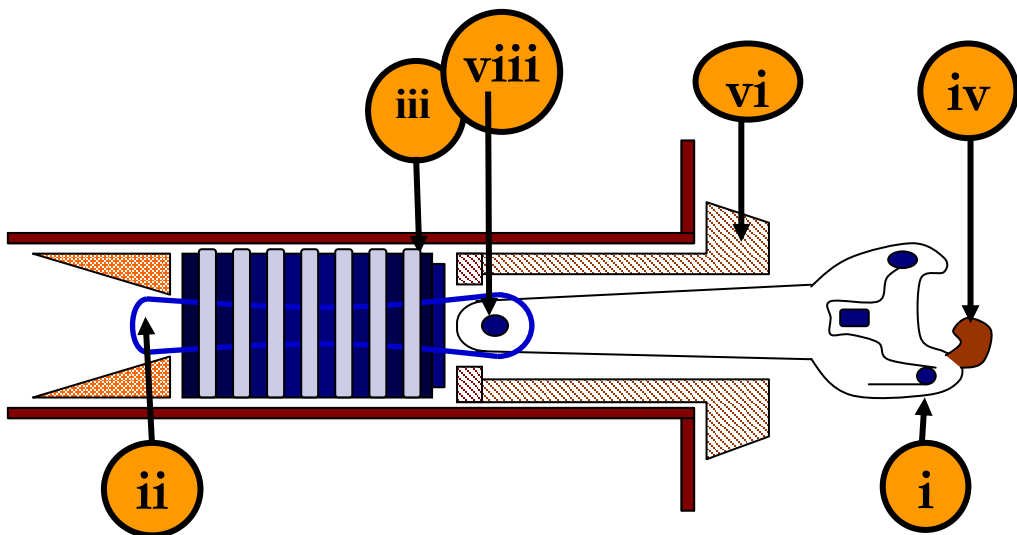

3.1.1 Coupler Body

Sketches of various components of CBC are shown on the following pages. The usual location of breakage of the components are marked as A, B, C.

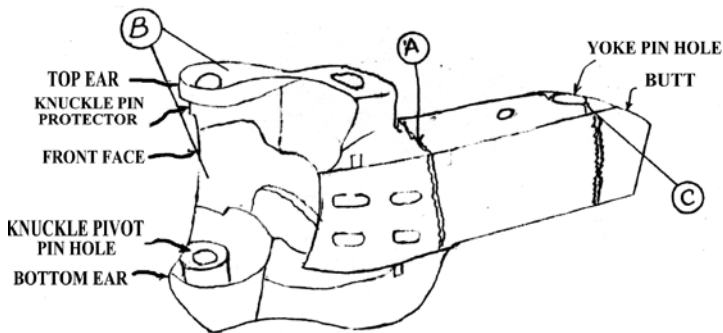

COUPLER BODY WITH SHANK

3.1.2 Yoke

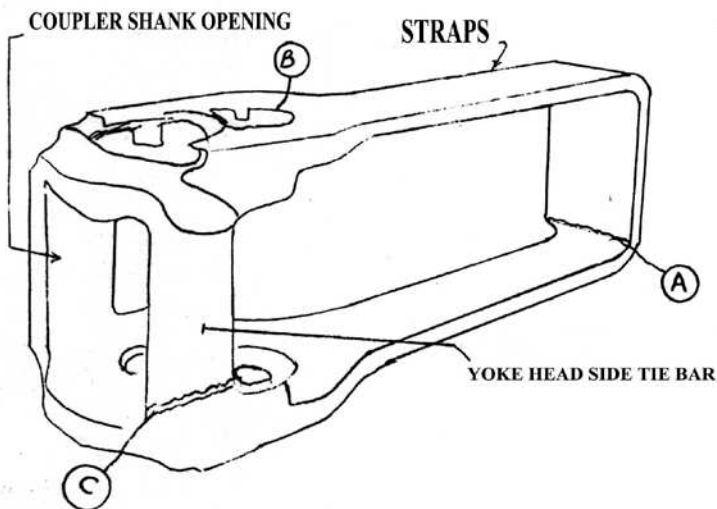

3.1.3 DRAFT GEAR

Draft gears are provided for wearing shockloads of CBC unit to avoid damages to wagon body. The excessive slack in draft gears is not permitted and should be either reduced or eliminated. The maximum permissible free slack in the draft gear is 25 mm (1”) after which it shall be removed or it to be either reclaimed or condemned. The free slack can be determined by first sledging the coupler back solid and than measuring the clearance between the coupler horn and the striker face, next by inserting a long bar between the horn and striker face.

3.1.3.1 DRAFT GEAR MK-50

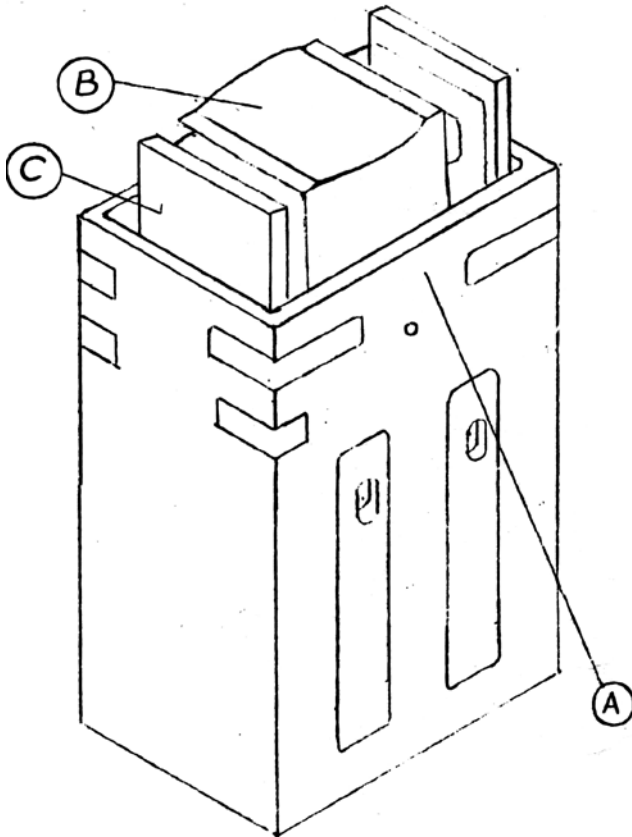

3.1.3.2 DRAFT GEAR RF 361

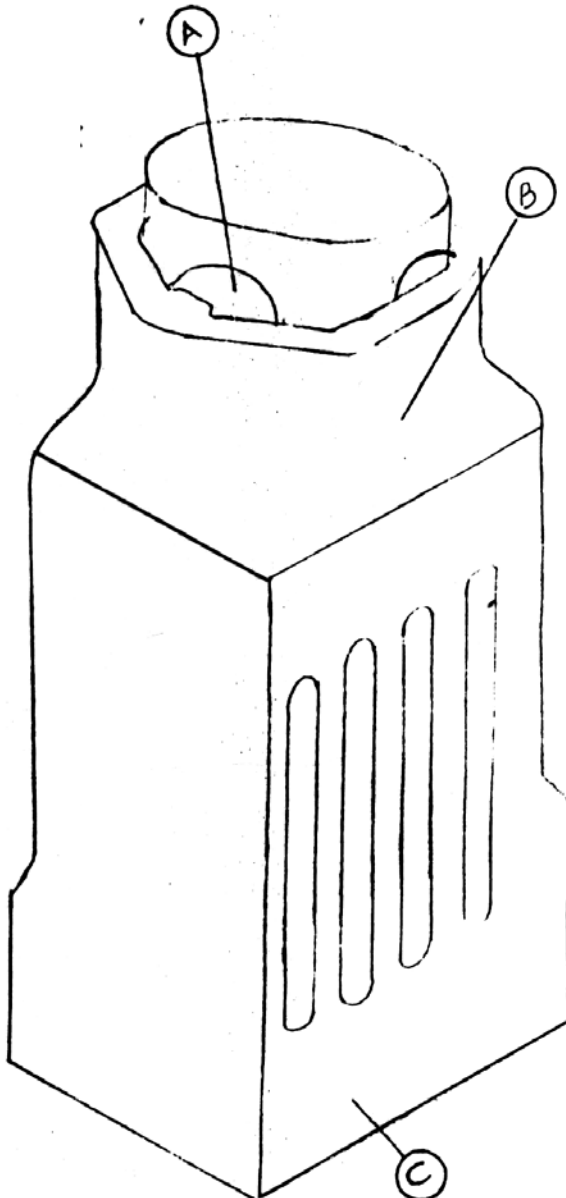

3.1.3.3 SECTIONAL VIEW OF DRAFT GEAR RF 361

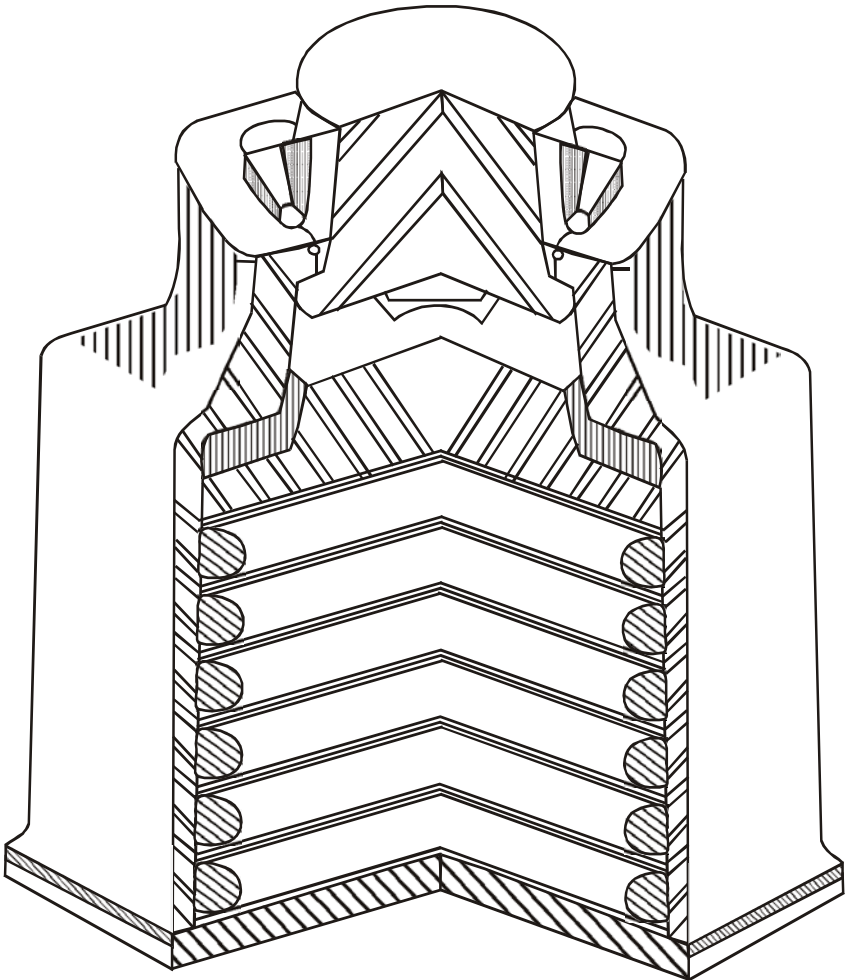

3.1.4 KNUCKLE

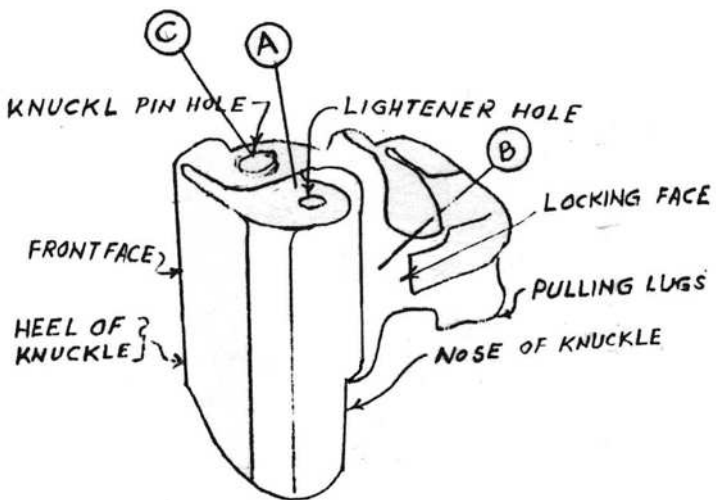
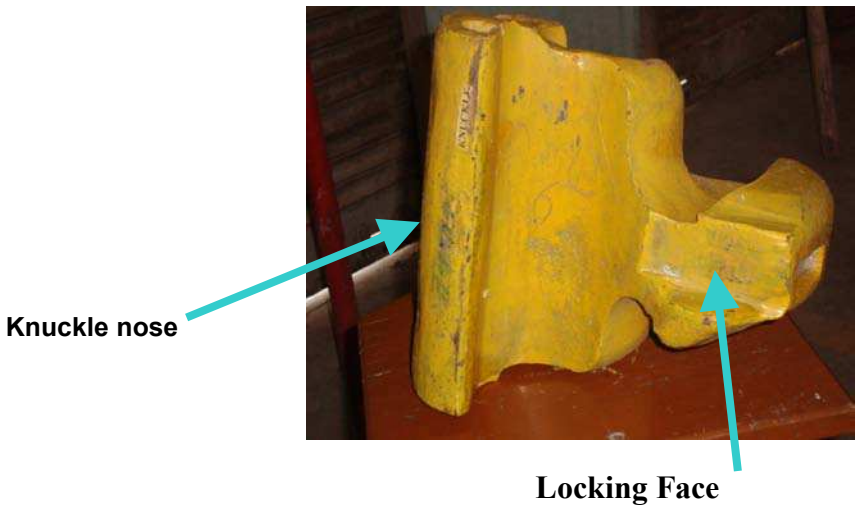

3.1.5 KNUCKLE PIN

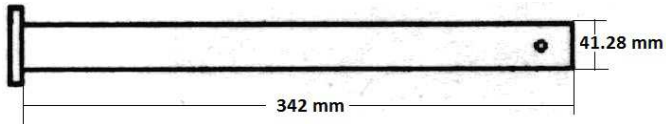

3.1.6 STRIKER CASTING PLATE

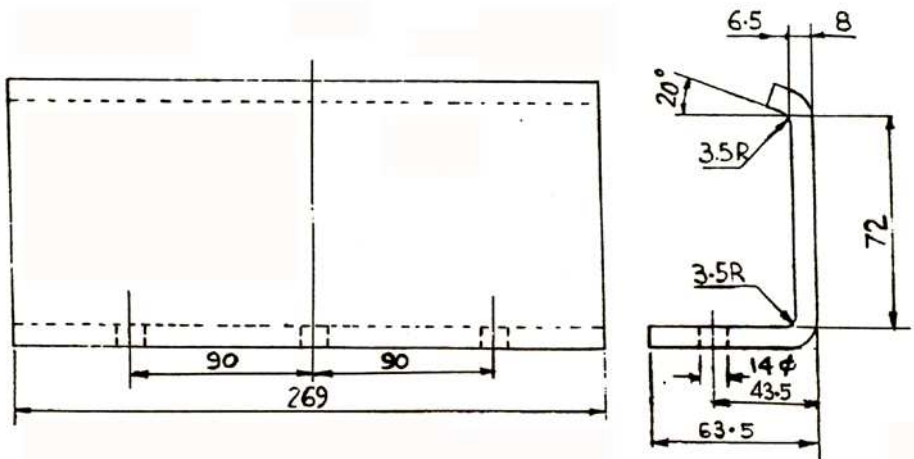

3.1.7 SHANK WEAR PLATE

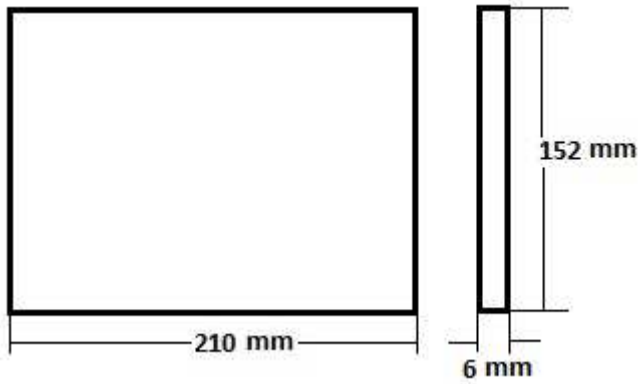

3.1.8 YOKE PIN

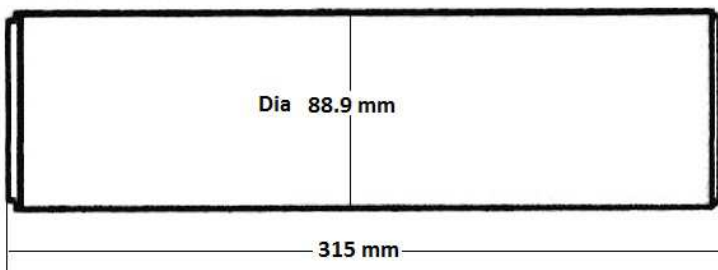

3.1.9 LOCKING ARRANGEMENTS

3.1.9.1 KNUCKLE THROWER

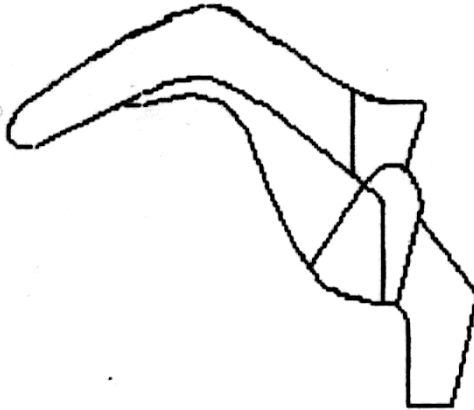

3.1.9.2 TOGGLE WITH LOCK LIFTER

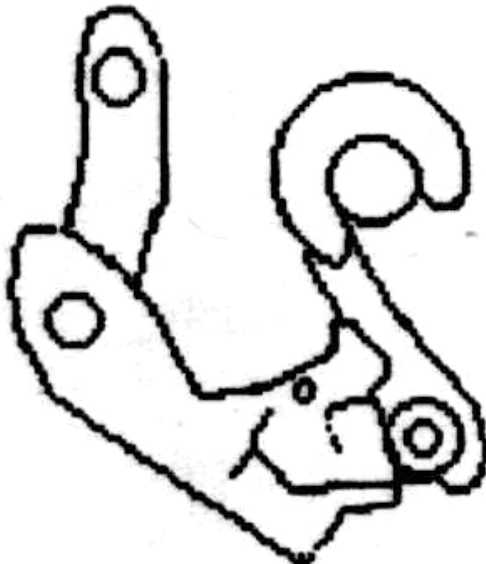

3.1.10 OPERATING MECHANISM

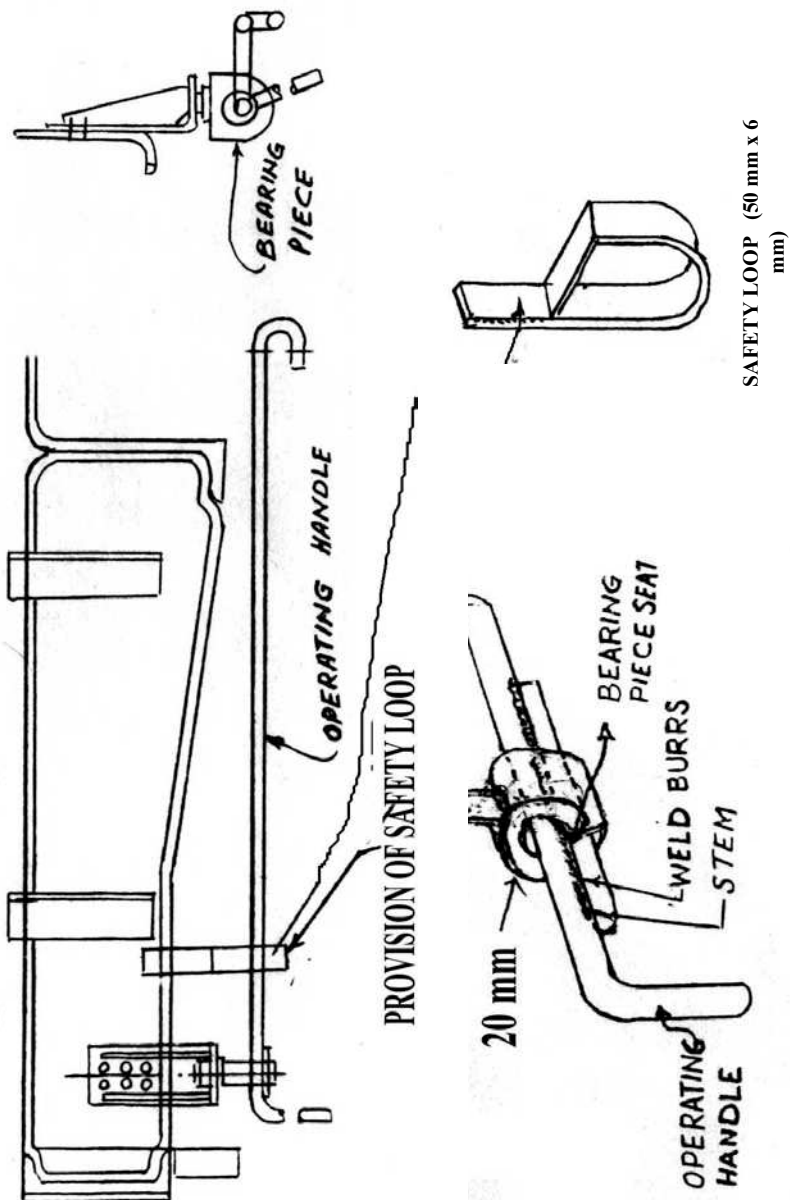

3.1.11 FOLLOWER

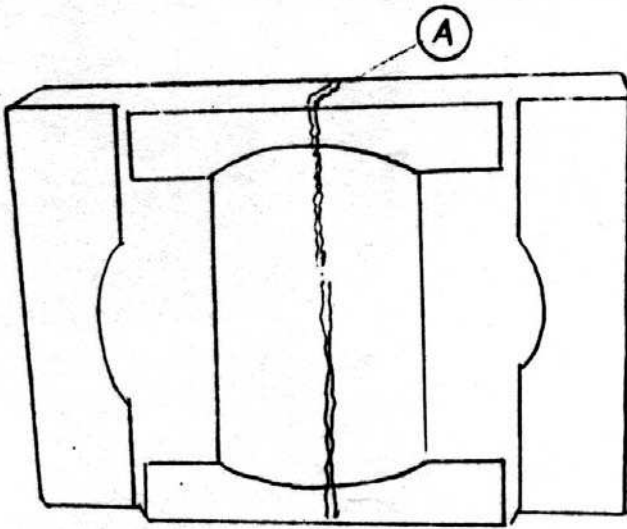

FOLLOWER

3.2 मापक यंत्र एवं उनका प्रयोग

MEASURING GAUGES & THEIR APPLICATIONS:

There is a scope for reduction in train parting cases by adopting good maintenance practices by C&W supervisors and Technicians while examining the wagons in the yards, during routine overhauling of wagons in depots and during periodical overhauling of wagons in workshops. The adequate material input and proper measurement and gauging of worn out/defective components of CBC during ROH and POH are very important for reducing the parting cases.

The following requisite drawings & gauges for inspection of all components should be available in ROH depots and workshops and shall be calibrated periodically. The following reference drawings & gauges shall be used:

Coupler Parts

Type of Components/Gauge	Drawing No
10 A Contour gauge No. 1,2,3	WD 84073-S-RC
Bottom anti-creep-vertical location No. 6	WD 84073-S-2-RC
Bottom anti-creep-horizontal location	WD 84073-S-2-RC
Top anti-creep vertical location	WD 84073-S4-RC
Pulling lug gauge-knuckle side	WD 84073-S-7-RC
Lock Chamber	WD 84073-S-9-RC
Lock Hole	WD-84073-S-10-RC
Knuckle bottom pulling lug	WD 84073-S-41-RC
Knuckle movable point	WD 84073-S-42-RC
Knuckle Hub	WD 84073-S-43-RC
Knuckle tail height	WD 84073-S-44-RC

Knuckle top pulling lug	WD 84073-S-45-RC
Gauge for Knuckle pin hole No. 4, 5	WD 84073-S-47-Rc

Types of components/Gauge	Drawing No.
Gauges for Knuckle	WD 00041-S-01-RC
Lock Toggle	WD 84073-S-58-RC
Knuckle thrower contour	WD 84073-S-66-RC
Lock lift assembly	WD 84073-S-76-RC
Composite gauges for connector	WD 84073-S-77-Rc
Knuckle pivot pin dia & length	WD 84073-S-96-RC

Coupler Shank

Type of Gauge	Drawing No.
Shank height	WD 84073 –S-15-RC
Pivot pin hole	WD 84073-S-20-RC

गार्ड आर्म एक्सपेन्शन की जाँच CHECKING OF GUARD ARM EXPANSION

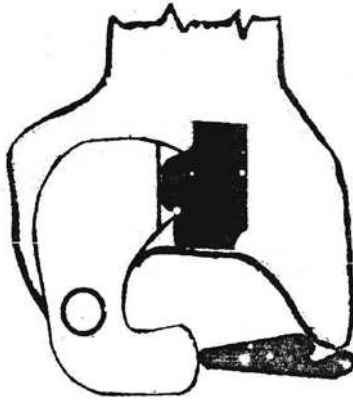

GAUGE NO. 1

- Apply the gauge no. 1 as shown.
- If gauge no. 1 passes, renew
 - 1) Knuckle 2) Knuckle pin 3) Lock

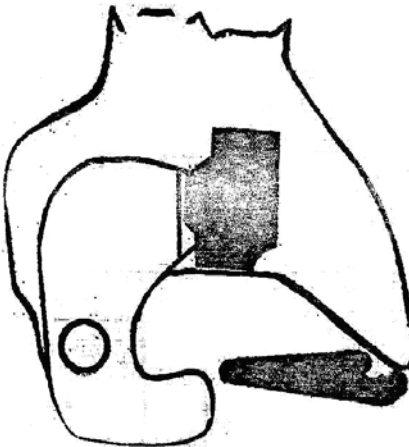

GAUGE NO. 2

- After replacing the above, if gauge no. 2 passes, renew the coupler body.
- **Reason - Guard arm expanded.**

गार्ड आर्म डिस्टोर्सन की जाँच CHECKING OF GUARD ARM DISTORTION

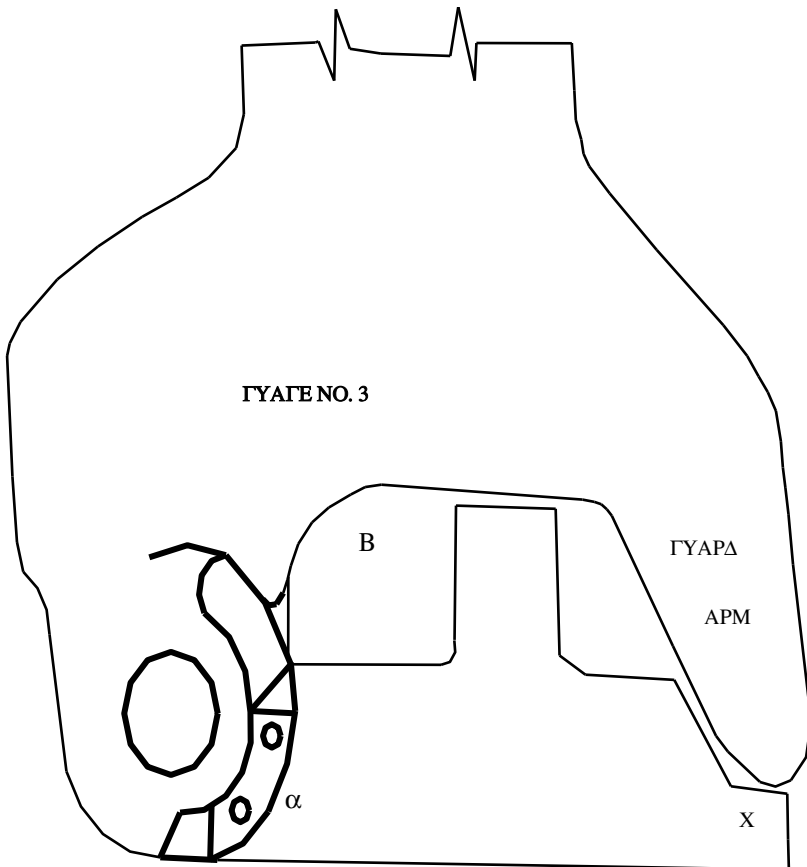

- Apply the gauge no. 3 as shown above.
When 'A' is in contact, if 'B' or 'C' touches, renew the coupler body.
- **Reason : Guard arm distorted.**
- Note: If guard arm distortion is more than 4.8 mm, it should be closed into normal.

स्ट्रेचड नक्कल की जाँच CHECKING OF STRETCHED KNUCKLE

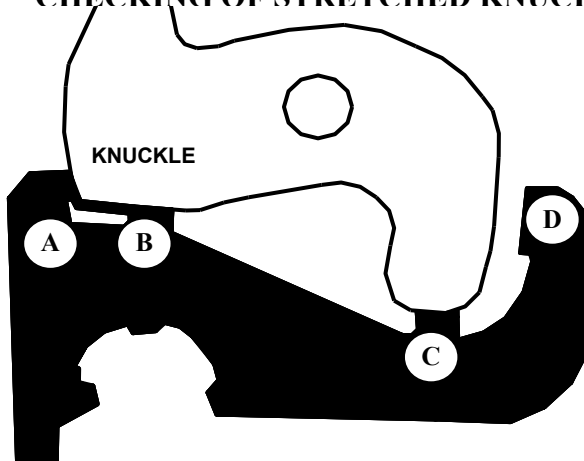

- Apply the gauge no. 4 as shown above.
- When A,B,C are in contact, there must be a clear gap at 'D'

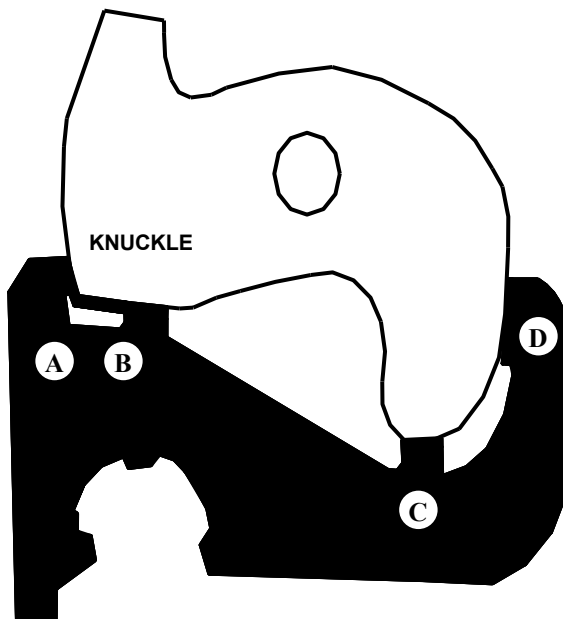

- If 'D' touches, renew the knuckle.
- Reason – Knuckle is stretched.

नक्कल नोच के टूटने की जाँच CHECKING THE KNUCKLE NOSE WEAR

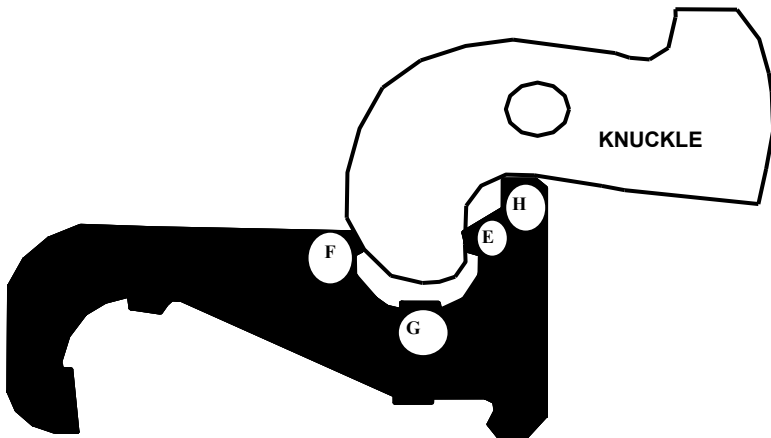

- Apply the gauge no. 4 (alliance-II) as shown above.
- When E, F, G are in contact, 'E' must not pass.

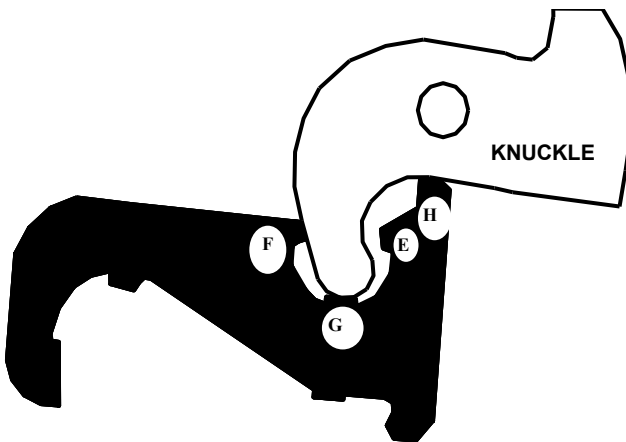

- If 'E' passes, renew the knuckle.
- **Reason – Excessive knuckle nose wear.**

नक्कल लॉकिंग फेस की जाँच CHECKING THE KNUCKLE LOCKING FACE

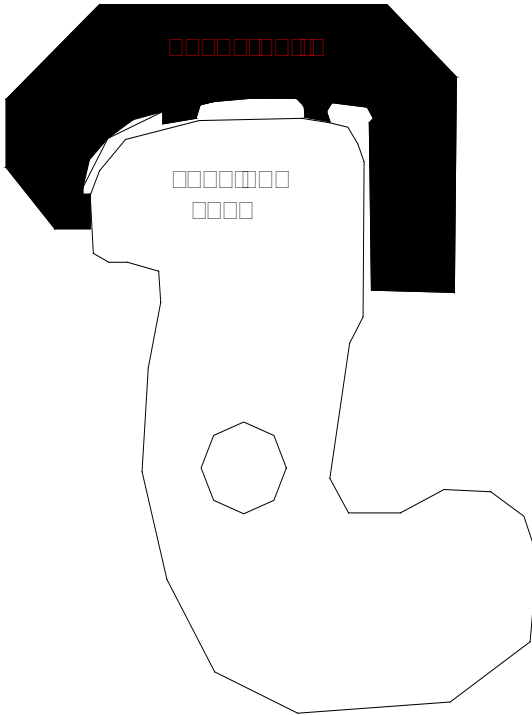

- Apply the gauge no. 5 as shown above.
- The gauge must not pass through vertically.
- If passes, renew the knuckle .
- **Reason : Excessive wear at locking face of the Knuckle.**

बॉटम फिल्टर की एन्टीक्रीप लेप की जाँच
CHECKING OF ANTI-CREEP LEDGE OF BOTTOM
LIFTER

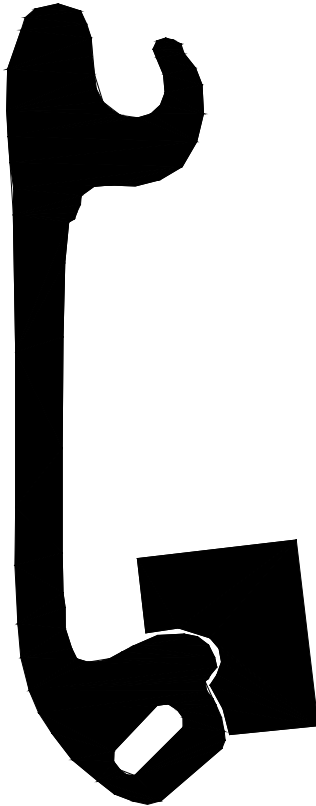

- Apply the gauge no. 6 as shown above.
- There should not be any clearance between gauge and bottom lifter.
- If there is a gap, renew the bottom lifter.
- **Reason : Ineffective anti -creep**

रोटरी लीवर के एन्टीक्रीप लग की जाँच CHECKING OF ANTI-CREEP LUG OF ROTARY LEVER

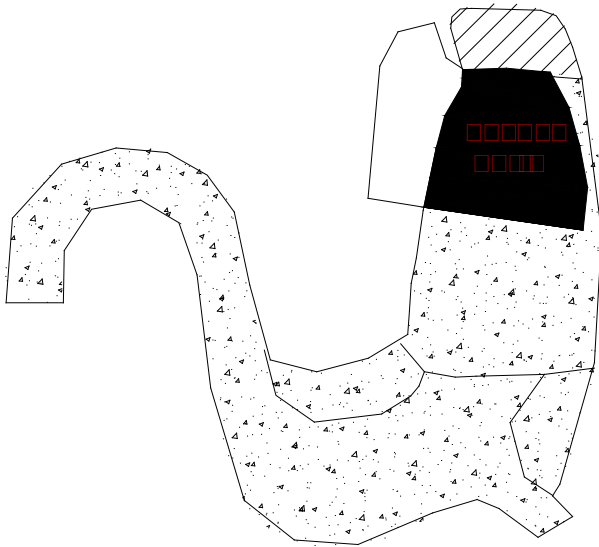

- Apply the gauge no. 7 as shown above.
- If gauge is not mating properly with the anti –creep lug (bridge) of rotary lever , renew the rotary lever.
- **Reason : Ineffective anti -creep**

लॉक वियर की जाँच CHECKING OF LOCK WEAR

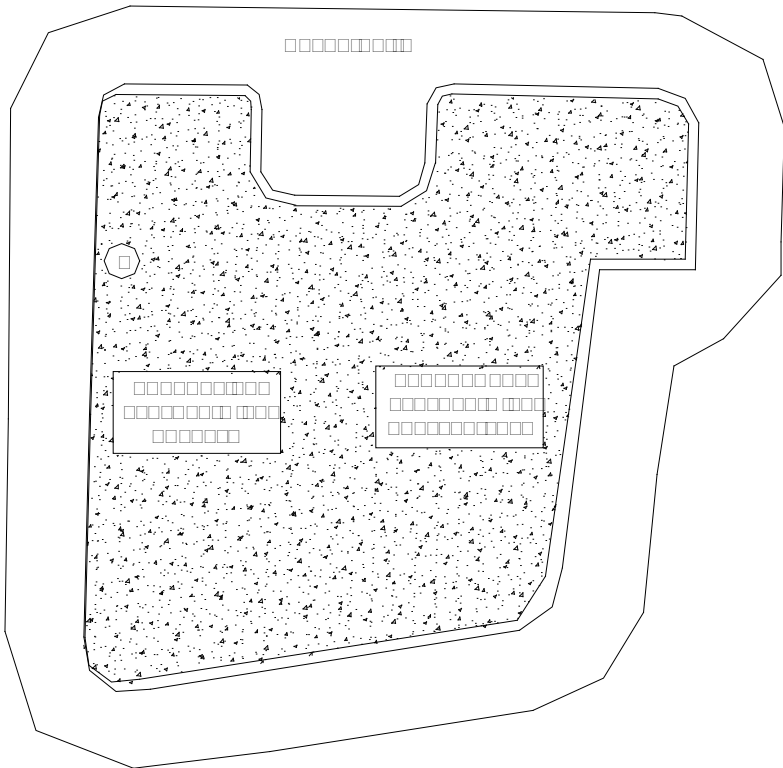

- Apply the gauge no. 8 as shown above.
- When the surface 'A' is in contact, if the gap is more than 3.2 mm at 'B', renew the lock.
- **Reason : There is a combined wear of lock at knuckle contacting surface & engagement surface with coupler body.**

3.3 सेन्टर बफर कपलर एवं ड्राफ्ट गियर की शक्ति

Strength of Centre Buffer Coupler & Draft Gear :

- a) Indian Railway uses AAR type centre buffer couplers having E-type head and F-type shank for freight stock on Broad gauge system. These couplers are generally as per requirements of AAR Specifications M-201.
- b) The draft capacity of the AAR coupler depends on the strength of knuckle which is weakest link in the assembly. The yield strength of knuckle of material AAR M201 Grade 'E' is 180 t.
- c) The draft load is transmitted through the knuckle, hub, pin pulling lug, coupler, yoke pin and draft gear.
- d) The buffing forces are taken by the draft gear through the knuckle pin, coupler, yoke pin takes the buffing forces etc.
- e) Buffing forces and tensile forces are transmitted to under-frame gradually through back stoppers and striker casting.

3.4 माल वाहन के ड्राफ्ट गियर एवं बर्किंग गियर के प्रकार

Types of Drafts and Buffing Gears on Freight Stock:

- i. Air brake freight stock is generally fitted with high capacity draft gear i.e. **RF-361, MK-50, HR-40** draft gears are being removed progressively.
- ii. In new design BOXNHL and BCNHL wagons, following types of draft gears are provided as per RDSO spec. No. WD-66-BD-06 are being provided.
 - i) Twin pack F-325G
 - ii) SL-76
 - iii) MK-325
 - iv) Power Guard

Warranty period of these draft gears in 60/72 months from date of commissioning/ manufacturing whichever is earlier.

- 3.5 **सी.बी.सी. की कार्यप्रणाली /Working out of CBC** – This happens when yoke pin drops due to breakage of support plate

resulting in the coupler shank coming out of the yoke. CBC can work out if the yoke or yoke pin is broken.

3.6 नक्कल का टूटना /Breakage of Knuckle –The incidences of knuckle breakage are very high on Indian Railways. It is seen that knuckle breakages are primarily due to casting defects combined with improper heat treatment and worn out knuckle being allowed in service beyond condemning size i.e. it had become too thin at the nose on account of wear. These conditions combined with impact loading due to any slackness in the coupler assembly results in knuckle failures.

3.7 वैगन के सी.बी.सी. अवयवों की मानक माप

Standard Dimensions for CBC items of Wagons

Sr. No.	Description	Standard limit	Condemning / Rejection limit	Reference for Std. Drg.	Reference for Cond.
1	Height of knuckle pin	342 mm	N/R	Drg. No. 62724	-
2	Knuckle pin dia.	41.28 mm	38 mm	Drg. No. 62724	G-76, Appendix- 9, Sr. no. 3
3	Knuckle pin securing hole size	7 mm	6 mm	Drg. No. 62724	-
4	Distance between knuckle nose and Guard arm face – with gauge no.1 with gauge no.2	135 mm 130 mm	138 mm 133 mm	G-76, Appendix- 3A. G-76, Appendix- 3B.	- -
5	Shank wear limit (Shank depth 171 mm new)	6.5 mm	164.5 mm	WMM, page no. 14 of 46, Ch.-9	WMM, page no. 14 of 46, Ch.-9
6	Shank plate	152x210x6 mm (6 mm thick)	5mm. thickness	Drg. No. 62724	G-76, Appendix- 9, Sr. no. 2
7	Knuckle expansion	292.47 mm	304.63 mm		
8	Knuckle original	286.34 mm	N/R		
9	Knuckle height	279.4 mm	N/R	Drg. No. 62724	-
10	Knuckle thickness	25.45 mm	15.95 mm		
11	Knuckle nose wear	18 mm	9.5 mm		G-76, Appendix- 9, Sr. no. 1
12	Knuckle pin washer outer dia.	51 mm	N/R	Drg. No. 62724	
13	Knuckle pin washer thickness	5 mm	N/R	Drg. No. 62724	
14	Yoke pin height	315 mm	310 mm	Drg. No. 62724	-
15	Yoke pin Dia	88.9 mm	85.9 mm	Drg. No. 62724	WMM, page no. 16 of 46, Ch.-9
16	Yoke pin hole	Dia- 95.25 mm	98.25 mm	Drg. No. 62724	WMM, page no. 16 of 46, Ch.-9

Sr. No.	Description	Standard limit	Condemning / Rejection limit	Reference for Std. Drg.	Reference for Cond.
17	Anti rotation lug	16x 16x210 mm	13 mm	Drg. No. SK-77543	-
18	Bearing piece bolt dia	25 mm	27.5 mm	G-76, Appendix- 8 B	-
19	Bearing piece slot	17.5 mm	19.5 mm	Drg. No. WD-00046-S-01	-
20	Operating rod dia	25 mm	N/R	Drg. No. WD-00046-S-01	-
21	Operating rod length	1414 mm	N/R	Drg. No. WD-00046-S-01	-
22	Bent portion of operating handle	400 mm.	N/R		-
23	Lock lift rivet length	49 mm	N/R	Drg. No. 62724	-
24	Lock lift rivet dia.	17.5 mm	18.5 mm	Drg. No. 62724	-
25	Lock lift lever rivet length	76 mm	N/R	Drg. No. 62724	-
26	Lock lift lever rivet dia.	8 mm	7 mm	Drg. No. 62724	-
27	Knuckle Yield strength	180 tonnes	N/R	WMM, page no. 19 of 46, Ch.-9	-
28	Coupler body Yield strength	205 tonnes	N/R	WMM, page no. 19 of 46, Ch.-9	-
29	Distance between coupler body head & striker casting	108 mm	133 mm	G-76 manual 10.1	

अध्याय /Chapter - 4.0

इंजिनमेनशिप

ENGINEMAN SHIP

4.1 त्रुटिपूर्ण इंजिनमेनशिप /Poor engineman ship

Reasons of Breakage of coupling or uncoupling due to Jerk/excessive tractive effort

The main reason for breakage of coupling is jerk due to excessive tractive effort, Pulling forces & pushing forces.

The reasons of jerk are spring slack & free slack. Spring slack is occurs due to compression of Draft gear at the time of braking. The limit of maximum spring slack is 5", the free slack occurs due to excessive gap between couplers which is approx. 1".

The jerk is developed -

- i) By drivers during run due to improper driving technique
- ii) Due to defect in loco such as wheel slip, Power Ground earth fault or shutting down of engine due to other reasons.
- iii) Application of Brake by banker pilot or by Guard during running.

Reasons of Generation of Jerk by Loco Pilot :

1. Sudden opening of Throttle notches.
2. Emergency Braking
3. Traction Power Cutting off
4. Faulty train operation on Gradient

4.2 ट्रेन पार्टिंग से बचने के उपाय/Measures to avoid Train Parting

The Loco Pilots have an important role to pay in preventing the train parting cases. Good driving skill is very important. Some of the guidelines useful for drivers are given as under :

- It is observed that additional shock load comes on the coupler when drivers apply traction before full release of brakes
- ***Starting of goods train after stopping***-wait for minimum 3 minutes in case of air brake train to release the brakes. (Ref. RDSO's Report No. MP.Misc-88/99 REV-0.01)
- Avoid jerky movement during starting and stopping train
- While attaching the loco on to the formation, attach with a little bump and push the formation back by about two meters to ensure that partially lifted locks drop into position. Then, pull the train ahead by half-a-wagon length, to identify the CBCs which are not locked. In the process, fouling mark should not be infringed.
- While starting a train, the notching up shall be gradual as to have smooth run out and thereby avoid the shock loading of CBCs.
- At enroute stations , LC gates, signals etc when the train is stopped for longer time the driver shall push back the train about two meters to ensure proper locking of CBCs which, might have been meddled with by trespassers/miscreants.
- While negotiating gradients, camel humps, maintain uniform speed, till the train passes the section.
- Before negotiating and ascending or descending gradients, attain the critical speed necessary to negotiate the section, so that uniform speed can be maintained while passing over the graded section
- After application of brake, sufficient time shall be given for the release of brakes on the entire formation, before accelerating.
- When continuous wheel slip is experienced, reduce the speed of the train, to avoid shock loading of CBCs.

- There shall be proper co-ordination between the leading driver and banker driver while negotiating the up-gradient in ghat section.

4.3 जर्क से बचने के उपाय/Measures to Avoid Jerks :

(A) *At Level* :

- Ensure that all couplings are correctly fitted. For this, Push the train back for about $\frac{1}{2}$ wagon length so that all the couplings are coupled properly.
- Ensure that brakes of the train are fully released, for ensuring this, time should be given for releasing the brakes. Sufficient B.P. pressure should be ensured and air flow indicator should be at constant position.
- Release the loco brakes after waiting for 10 seconds after opening of throttle.

(B) *Up gradient* :

- Release the train brakes before opening the throttle
- Open 2-3 notches by throttle
- Release Loco brakes
- On starting of train, open the throttle notch by notch precisely by keeping eye on needle of load meter.
- Reduce the throttle notches in case of wheel slipping.
- If Banker engine is attached, driver of Banker engine should first open notches.

(C) *Down Gradient* :

- Release Loco Brakes
- Allow train to move forward and attain the desired speed
- Use dynamic Brakes if required

(D) *On Sag* :

- Open the notches
- Release the loco Brakes and open 1-2 Notches
- When the full train comes in a stretch, advance the notches, one by one by observing load meter.

(E) Unduelading Gradient :

- i) Open 1st Notch
- ii) Release the Loco Brakes
- iii) When train started, open second notch and when meter is stabilized, open the notches as desired.

(F) On Hump :

- i) Release train Brakes before opening of throttle
- ii) Open 2-3 Notches by throttle
- iii) Release Loco Brakes
- iv) On starting of train, open the throttle precisely notch by notch observing needle of the load meter
- v) Reduce throttle notches when wheel slip experienced
- vi) In case of banker engine, the banker driver should first open the notches

(G) On Run of Train :

- (i) Open notches one by one
- (ii) To control the speed of the train by dynamic brake, apply air brake in train by A-9 for bunching the load.
- (iii) During Dynamic braking advance selector slowly and releasing should also be ensured slowly
- (iv) Reduce the notches on up gradient during wheel slip
- (v) Sufficient releasing time must be ensured for full releasing of the load after application of brakes. Advance the throttle for increasing the speed only after full releasing of load
- (vi) Do not use loco brakes in running train
- (vii) Keep watch over the Air flow indicator during running
- (viii) Do not apply brakes suddenly
- (ix) Do not open notches suddenly
- (x) Keep contact with Guard/banker Pilot on walkie talkie
- (xi) Running of train should be ensured properly on Gradients
- (xii) Do not use Loco brake in conjunction braking as far as possible during first brake application

(H) At the time of Application of brake in train :

- (i) Apply brakes properly
- (ii) After Dynamic braking, notches should be taken after suitable gap
- (iii) After stopping the train, B.P. Pressure recreation must be ensured.
- (iv) On up gradient, try to stop the train on some notches and after stopping of train apply loco brakes.
- (v) Apply loco brakes after stopping the train

अध्याय /Chapter- 5.0

आर.ओ.एच. एवं पी.ओ.एच. में गाड़ी
के परीक्षण के दौरान सावधानियाँ

ATTENTION DURING TRAIN EXAMINATION, ROH & POH

5.1 यार्ड में गाड़ी के परीक्षण के समय सावधानी /Attention during Yard Examination:

- i) The operating handle should not be bent and should be properly held in the bearing piece.
- ii) Ensure the correct geometry of operating handle.
- iii) Ensure that there is no excessive wear in anti rotating lug, the standard section of anti rotation lug is 16 mm x 16 mm. Anti rotation lug should not be round.
- iv) Ensure that there is no excessive wear in the slot provided in bearing piece. The standard width of slot is 17.5 mm.
- v) There should be no excessive play between anti rotation lug and slot provided in bearing piece.
- vi) Ensure that the bearing piece pin is properly welded to hanger bracket.
- vii) Ensure that the hook end of operating handle is properly engaged with lock lift lever connector.
- viii) Ensure that all the components of lock lift assembly such as toggle lever connector and lever hook are properly riveted.
- ix) Ensure that anti creep lug of lever connector is not excessively worn out.
- x) Ensure that the distance between the bottom of CBC head and anti creep lug is not excessive (should not be more than 1").
- xi) Ensure that the variation between the CBC heights of adjacent wagons is within the permissible limit of 75 mm.

- xii) Ensure that knuckles are good, pin is standard and properly secured.
- xiii) Ensure that the CBC projection is within permissible limits of 108 + 25 mm.
- xiv) Ensure that proper additional operating handle safety bracket is properly welded.
- xv) Ensure that auxiliary anti-creep lug was not excessively worn out at tip.
- xvi) Check condition of yoke pin support plate and condition of rivets.
- xvii) Check coupler head, knuckle for cracks.
- xviii) Check yoke pin support plate is loose.
- xix) Check broken yoke.
- xx) Don't allow jammed pistons or brake binding, attend it before dispatch.
- xxi) Do ensure that the hand brakes are released.
- xxii) Check for cracks on the coupler body and knuckle.
- xxiii) Don't allow excess wear on the knuckle.
- xxiv) Don't lubricate or paint any of the CBC components.
- xxv) Check the rear stopper for damages.
- xxvi) Check for damages of draft gear.

5.2 आर.ओ.एच. के दौरान सावधानी /Attention during ROH

Freight stocks are generally subjected to routine overhauling "ROH" after an interval of 18 months. Various worn out CBC parts are to be replaced during ROH. Following areas needs to be looked into during ROH :

- i) Check CBC contour condition by using gauge No.1 & 2 and follow the procedure for changing the defective parts as per technical leaflet G.76.
- ii) Check knuckle stretch and nose wear by using gauge no.3 and replace the parts if necessary.
- iii) Check the condition of shank wear plate, if the wear is more 5 mm replace the same and use M5 class of electrode only for welding.

- iv) Check the condition of CBC draft gear, yoke lock, back and front stopper rivets, yoke pin support plate rivets, striker casting wear plates.
- v) Ensure correct CBC heights
- vi) Check the condition of knuckle pin, lock lift assembly, knuckle thrower etc.
- vii) None of the Coupler components shall be lubricated.
- viii) Do check the coupling for damages and replace if required.
- ix) Do ensure the draw bar projection is within limits, and draw bar springs are tight.
- x) Provide all the components of the lock lifting assembly.
- xi) Check for damaged or bent operating lever, rectify it.
- xii) Check the anti creep mechanism, attend it if required.
- xiii) Check the shank and striker casting wearing plates, if worn-out.
- xiv) Check the front and rear stoppers.
- xv) Check for damaged draft gear.
- xvi) Check the yoke for excess wear or breakage.
- xvii) Don't allow excess free slack, attend properly.
- xviii) Test the cylinders, attend, if jammed.
- xix) Weld properly the bearing piece safety strap.
- xx) Check the securing of the bearing piece and rivets of the brackets.
- xxi) Don't use improper locks for CBCs, use the correct one.

5.3 पी.ओ.एच. के दौरान सावधानी /Attention during POH

- i) CBC shall be removed from the wagon at every year.
- ii) Proper checking of the knuckle by using requisite gauges and carry out replacement of worn out knuckles.
- iii) Proper attention to draft gear during POH. Dead draft gears shall be replaced.
- iv) Reclamation of knuckle is not permitted at all.
- v) Check the yoke for elongation of yoke pin holes and cracks if any. No reworking is permitted on yoke.

- vi) Check the striker casting for wear and replace the wear plate with new one. Make sure that wear plate is marking contact with striker casting surface uniformly and use M-5 class electrode only for welding.
- vii) Check the CBC shank wear plate for wear. Excessively worn wear plate shall be replaced with new one. Ensure that M5 class electrodes are used for welding.
- viii) Cranks on the coupler body should not be repaired by any method like deposition of weld material. Similarly building up of worn surfaces such as pulling lugs, buffing shoulders, lock walls etc. are prohibited.
- ix) The design travel of draft gear shall not be less than 50 mm in buff and combined draft and buff gear shall not exceed 165 mm.
- x) The draft gear shall be checked thoroughly during POH for any defect on account of poor design, material fault and bad workmanship as they are under warranty for a period of 54 months from the date of supply of 42 months from the date of commissioning whichever is earlier.
- xi) Detailed inspection of all coupler component and draft gears also their reclamation to be undertaken.
- xii) No painting or lubrication of coupler to be done during assembly. After removal, the coupler to be operated a few times to ensure free movement of components.
- xiii) Railway board ordered, not to reclaim any knuckle after December 2002.
- xiv) After assembly of the coupler in wagon body, anti creep to be checked meticulously and in every case to ensure its proper functioning according to method.
- xv) Free movement and articulation at the joints between the components of rotary lock lift gear to be ensured by proper riveting. No welding of joints to be restored to.
- xvi) Ensure that coupler height should be maintained as specified in IRCA part III, rule no.2.13.7 as excessive difference in two adjacent couplers would cause excessive wear and stress on knuckle.

5.4 परिचालन एवं यार्ड कर्मचारियों के लिए सावधानी

Attention by Operating and Yard Staff

1. During shunting, keep both the knuckles in open position.
2. Couple CBC stocks with a little bump.
3. Ensure the knuckles are locked, after shunting.
4. Marshal loaded stock in front and empty stock in rear always.
5. Do not allow empty stock in between loaded stock.
6. Do not exceed the tonnage of the train than the authorized limit.
7. Reducing of train tonnage than the authorized limit may be considered during monsoon/bad weather on section where heavy wheel slip is experienced.
8. If any CBC defect is noticed in front of C&W staff, immediately advise for its rectification, without delay.
9. Avoid stopping of trains at unscheduled places, where cases of trespassing is possible.
10. Take off signals well in advance for approach of the train.
11. Avoid taking off or putting off signals, as soon as the train reaches the signals.
12. Avoid stopping the train at signals situated on up gradients.
13. Do work the train with a free and relaxed mind.
14. Don't open and close throttle frequently.
15. Do aware for the caution spot, and control your train well in advance.

Recommendations:

- Supervisors and Technical Staff associated with train examination, ROH & POH shall be trained adequately to

- carry out inspection of CBC components with requisite gauges during ROH and POH of wagons.
- The requisite gauges for inspection of all components should be available in ROH depots and workshops and shall be calibrated periodically.
 - Procurement of coupler spares of proper quality as per requirements needs to be ensured. There shall be Rate contracts with RDSO approved sources to ensure material availability in time.
 - Regular technical audits shall be carried out by RDSO at manufacturer's premises to keep check on manufacturing process, methods, usages of raw material and trained Supervisors and Technicians.
 - Locking arrangement should be provided in the uncoupling mechanism of CBC to guard against any authorized tampering.
 - Compulsory training of Loco Pilots on dynamic simulator with simulation modules of their area of train operation.

अध्याय /Chapter 6.0

चैक लिस्ट

CHECK LISTS

6.1 ट्रेन पार्टिंग की संयुक्त अन्वेषण के लिए चैक लिस्ट

Check List for Joint Investigation Report of Train Parting

General particulars:

Date		Km No.	
Division		Section blocked	
Time		Signal aspect	
Section		Curvature	
Gradient		Weather condition	
C/Order		Kms of caution Order:	

Train Particulars:

Train No.		Loco (s) No	
Load / Tonnes-		Homing Shed of loco	
Commodity		Loading station	
Last Exam. Station		BPC Date / %	
Rly / Divn. -		BPC No	
CC /Pm /End to end		Air/Vacuum brake	

Driver's particulars / (Train Engine & Banker)

Driver's Name		HQ	
Qualification		Safety Category	
Date of Appointment			
Guard's Name		HQ	

Affected & Adjacent Wagon's Particulars

Sr. No.	Wagon No.	Class	Rly	R / Date	POH	ROH	Position from Loco
1							
2							

Screw coupling / CBC (Alliance II / AAR-HT):

Bearing: 16T RB / 20T RB / 20.3 T CTRB:

Whether empty / loaded

6.2 प्रभावित वैगन के लिए चैक लिस्ट Checklist for Affected Wagons

CBC & Knuckles – HT/NHT Stamping Particulars –

- Knuckle broken –
- CBC -crack any location –
- Zone of breakage (A / B / C / D) –
- Structure of broken surface (uniform / coarse) –
- Any mark of Blow Hole -
- Origin of breakage (External / Internal / dent or hit mark) -
- Nature of breakage (Fresh or partially fresh) –
- Approximate % age of crack (Fresh/old/any hair crack existing previously) –
- Any foreign material inside casting (stone / hard material, etc.)
- Any other casting defect (Core sand deposit / uneven hard surface) –
- Knuckle is reclaimed by welding (Yes / No)
- CBC lock broken, fresh / Old with % -
- Any manufacturing defects on CBC lock (crack / unusual metal projections, etc)

Draft & Assembly

- Type of draft gear – (RF 361 / SL – 76 / MK-50 / HR-40)
- Draft gear condition (dislocated / tilted / stiff)
- Front end follower (intact with rivet / worn out)-

- Yoke pin (badly embedded in the yoke pin support plate) -
- Yoke pin support plate (intact with sound rivet) -
- Any other defect noticed –

Operational Aspects

- Statement of train drivers obtained or not -
- Statement of Banker's drivers obtained –
- Conclusions from statement of the drivers –
- Statement of Guard obtained or not
- Is there any empty wagon between two loaded wagons?
Fluctuation of OHE voltage (as per SCADA report) –
- Tripping of DJ- as per driver statement & speedometer floppy– Operation of dynamic braking, effectiveness of brake system from locomotive to the load – as per Dr's statement –
- Any evidences of wheel slipping , brake binding of the rake as per Dr & Gd statement –
- Signal aspect. (Raised up on approach/ given on approach) –
- AFI condition while notching up.

Loco particulars:

- Dynamic Brakes : Working/Not working :
- Air Flow Indicator: Working/Not working :
- Notches –
- BP Pressure (Engine & Brake van) –
- MR / PT set No. –
- Flasher light (Wkg / Not working) –
- Speedometer (Wkg / Not working) –
- Release time after dropping 1 kg/cm² of BP pressure –
- Jerk while starting–
- Conjunction braking (Working / Not working) –

Track Particulars: -

- (a) Level (b) Rising (c) Falling (d) Curve right / left (e)
 Straight (f) Banner flag on track (g) Uneven rail joints (h)
 Cross over turn out (i) Camel hump (j) Vertical curve

Time particulars:-

Time left from station ----- at-----hrs.

Time arrival next station -----at -----hrs.

Running time of section –

Total section blocked –

Nature of Occurrence –

(a) While notching up (b) While notching down (c) During normal run (d) Coasting (e) While starting after stopping (f) While controlling (g) While observing caution order at km no.----
 ----- (h) Signal on approach (i) Running at the time of starting (j) Brake binding -on wagon no _____ ,position from engine (k) Gap between two portions _____mtrs (i) While entering loop line.

Speed of train at the time of incidence - _____ kmph

Date of investigation:

Investigation:

Findings/Conclusion:

Responsibility:

**Signature -
 Name -
 Designation -**

**Signature -
 Name -
 Designation -**

**Signature –
 Name –
 Designation –**

6.3 Check List for Investigation of CBC Uncoupling

General particulars:

Date		Block Section &KM	
Division		Section blocked	
Time		Signal aspect	
Section		Curvature	
Gradient		Weather condition	
C/Order		Kms of caution Order:	

Train Particulars

Train No.		Loco(s) No.	
Load / Tonnes-		CC+8+2/CC+6+2	
Commodity		Loading station	
Last Exam. Station		BPC Date / %	
Rly / Divn. -		BPC No	
CC /Pm /End to end		Air/Vacuum brake	

Driver's particulars / (Train Engine & Banker)

Driver's Name		HQ	
Qualification		Safety Category	
Date of Appointment		Nominated LI	
Guard's Name		HQ	

Affected & Adjacent Wagon's Particulars

Sr. No.	Wagon No.	Class	Rly	R / Date	POH	ROH	Position from Loco
1							
2							

Screw coupling / CBC (Alliance II / AAR-HT):

Bearing: 16T RB / 20T RB / 20.3 T CTRB:

Whether empty / loaded —

Observations to be Recorded by CWI/SSE/SE(C&W) for CBC Uncoupling

SN	Components	Affected Wagon	Adjacent Wagon
A	CBC Uncoupling lever handle	----	----
01	Over all length in straight line (Centre of hook to centre of rod) Std. 1414 mm, for BLC- 1063 mm		
02	Total length of bent end (Std. 400 mm)		
03	Geometry of CBC uncoupling lever handle (Straight/Bent)		
04	Anti rotational lug size (210 mm long, cross section 16X16 mm)		
05	Condition of uncoupling lever handle bracket & additional bracket		
B	Bearing piece	----	----
01	Slot gap in the bearing piece (Std. 17.5 mm)		
02	Bearing piece pin (Bent/Straight)		
03	Bearing piece pin secured with proper		

	washer/Nut or not		
04	Bearing piece pin dia (Std. 24 mm)		
C	CBC Knuckle, Coupler & Fittings	----	----
01	Dropping of locking piece to proper depth & Toggle is seen.		
02	Gap between knuckle nose & guard arm to be checked by gauge No.2 first and then with gauge No.1 (Max. gap 133 mm)		
03	Wear of the knuckle to be checked with gauge No. 3 (Within limit/Beyond permissible limit)		
D	CBC Drooping	----	----
01	CBC height from centre of track (Std. Min.1030 mm & Max. 1105 mm)		
02	CBC Shank wear plate (Worn out/Missing or OK)		
03	CBC Striker casting wear plate (Worn out/Missing or OK)		
E	Condition of Knuckle thrower (Worn out/Missing or OK)		
F	Lock lift assembly	----	----
01	Condition of lock & its slot for free movement of toggle pin. (worn out or OK)		
02	Condition of toggle (Worn out/Missing or OK)		
03	Condition of both rivets (Worn out/Missing or OK)		

SN	Components	Affected Wagon	Adjacent Wagon
04	Condition of Auxiliary Anti-creep lug (Worn out or OK). The condition to be checked by pressing rotary lever with the help of thumb towards striker casting to enter in the bottom cavity of CBC body (Through which toggle enters) without operating/Touching CBC operating handle . If it goes in that, indicates anti-creep protection failure, in that case, necessary repairs to articulated assembly be ensured on the wagon.		
05	Whether toggle is seen properly when CBC lock piece is in fully dropped condition and CBC in locked condition.		
G	Any other observations:		
H	Conclusion:		
I	Responsibility		
J	Repercussion		

Signature :

Name of CWI/SSE/SE(C&W) :

Depot :

हमारा उद्देश्य

अनुरक्षण प्रौद्योगिकी और कार्यप्रणाली को उन्नयन करना तथा उत्पादकता और रेलवे की परिसम्पत्ति एवं जनशक्ति के निष्पादन में सुधार करना जिससे अन्तर्विषयों में विश्वसनीयता, उपयोगिता और दक्षता प्राप्त की जा सके।

यदि आप इस संदर्भ में कोई विचार और विशेष सुझाव देना चाहते हों तो कृपया हमें इस पते पर लिखें।

संपर्क सूत्र : निदेशक (यांत्रिक)

पत्राचार का पता : भारतीय रेल
उच्च अनुरक्षण प्रौद्योगिकी केन्द्र,
महाराजपुर, ग्वालियर म. प्र.
पिनकोड 474 005

फोन : 0751-2470803
0751-2470890

फैक्स : 0751-2470841

OUR OBJECTIVE

To upgrade maintenance technologies and methodologies and achieve improvement in productivity and performance of all Railway assets and man power which inter-alia would cover reliability, availability, utilisation and efficiency.

If you have any suggestions and any specific comments, please write to us.

Contact person : *Executive Director*

Postal address : *Indian Railways,
Centre for Advanced
Maintenance Technology,
Maharajpur, Gwalior.
Pin code - 474 005*

Phone : *0751- 2470803*

Fax : *0751- 2470841*

Email address : edcamtech@gmail.com