

EVALUATION AND PREDICTION OF THE TENSILE  
PROPERTIES OF ASPHALT-TREATED MATERIALS

by

William O. Hadley  
W. Ronald Hudson  
Thomas W. Kennedy

Research Report Number 98-9

Evaluation of Tensile Properties of Subbases  
for Use in New Rigid Pavement Design

Research Project 3-8-66-98

conducted for

The Texas Highway Department

in cooperation with the  
U. S. Department of Transportation  
Federal Highway Administration

by the

CENTER FOR HIGHWAY RESEARCH  
THE UNIVERSITY OF TEXAS AT AUSTIN

May 1971

The opinions, findings, and conclusions expressed in this publication are those of the authors and not necessarily those of the Federal Highway Administration.

## PREFACE

This is the ninth report in a series dealing with research findings concerned with the evaluation of the properties of stabilized subbase materials. This report provides a detailed investigation of the effect of seven factors on the tensile properties of asphalt-treated materials. The report also includes prediction equations in terms of the important factors which can be used to estimate modulus of elasticity, Poisson's ratio, tensile strength, and failure strain of any combination of the factors.

This report is a product of the combined efforts of many people. The assistance of the Texas Highway Department contact representative, Mr. Larry Buttler, is gratefully appreciated and the support of the Federal Highway Administration, Department of Transportation, is gratefully acknowledged. Special appreciation is due Messrs. Pat Hardeman, Jim Anagnos, and Stan Stokes for their assistance in the test program, and thanks are also due to the Center for Highway Research staff who assisted with the manuscript.

William O. Hadley  
W. Ronald Hudson  
Thomas W. Kennedy

March 1971

## LIST OF REPORTS

Report No. 98-1, "An Indirect Tensile Test for Stabilized Materials," by W. Ronald Hudson and Thomas W. Kennedy, summarizes current knowledge of the indirect tensile test, reports findings of limited evaluation of the test, and describes the equipment and testing techniques developed.

Report No. 98-2, "An Evaluation of Factors Affecting the Tensile Properties of Asphalt-Treated Materials," by William O. Hadley, W. Ronald Hudson, and Thomas W. Kennedy, discusses factors important in determining the tensile strength of asphalt-treated materials and reports findings of an evaluation of eight of these factors.

Report No. 98-3, "Evaluation of Factors Affecting the Tensile Properties of Cement-Treated Materials," by Humberto J. Pendola, Thomas W. Kennedy, and W. Ronald Hudson, presents factors important in determining the strength of cement-treated materials and reports findings of an evaluation by indirect tensile test of nine factors thought to affect the tensile properties of cement-treated materials.

Report No. 98-4, "Evaluation of Factors Affecting the Tensile Properties of Lime-Treated Materials," by S. Paul Miller, Thomas W. Kennedy, and W. Ronald Hudson, presents factors important in determining the strength of cement-treated materials and reports findings of an evaluation by indirect tensile test of eight factors thought to affect the tensile properties of lime-treated materials.

Report No. 98-5, "Evaluation and Prediction of the Tensile Properties of Lime-Treated Materials," by Walter S. Tulloch, II, W. Ronald Hudson, and Thomas W. Kennedy, a detailed investigation by indirect tensile test of five factors thought to affect the tensile properties of lime-treated materials and reports findings of an investigation of the correlation between the indirect tensile test and standard Texas Highway Department tests for lime-treated materials.

Report No. 98-6, "Correlation of Tensile Properties with Stability and Cohesimeter Values for Asphalt-Treated Materials," by William O. Hadley, W. Ronald Hudson, and Thomas W. Kennedy, presents a detailed correlation of indirect tensile test parameters, i.e., strength, modulus of elasticity, Poisson's ratio, and failure strain, with stability and cohesimeter values for asphalt-treated materials.

Report No. 98-7, "A Method of Estimating Tensile Properties of Materials Tested in Indirect Tension," by William O. Hadley, W. Ronald Hudson, and Thomas W. Kennedy, presents the development of equations for estimating material properties such as modulus of elasticity, Poisson's ratio, and tensile strain based upon the theory of the indirect tensile test and reports verification of the equations for aluminum.

Report No. 98-8, "Evaluation and Prediction of Tensile Properties of Cement-Treated Materials," by James N. Anagnos, Thomas W. Kennedy, and W. Ronald Hudson, investigates, by indirect tensile test, six factors affecting the tensile properties of cement-treated materials, and reports the findings of an investigation of the correlation between indirect tensile strength and standard Texas Highway Department tests for cement-treated materials.

## ABSTRACT

The increased use of asphalt-treated subbases in rigid pavement structures has created the need for a rational procedure by which to design these subbases. A design procedure based upon layered theory (Ref 1) is presently under development at The University of Texas at Austin to satisfy this need. This theoretical design method consequently requires that material characterization constants such as modulus of elasticity, Poisson's ratio and failure strains be estimated for a variety of asphalt-stabilized materials. Estimates of these properties can be obtained from a carefully conducted indirect tensile test.

In previous work (Ref 2) tensile strengths of asphalt-stabilized materials were evaluated in terms of a variety of qualitative and quantitative factors. That particular study provided insight into the complexity of the effects produced by a number of factors and interactions on the tensile strength of asphalt-treated materials but could not evaluate satisfactorily the nature of these effects. Subsequent to this study a technique (Ref 3) for estimating the additional characterization constants of modulus of elasticity, Poisson's ratio, and tensile failure strains was developed which would allow for a detailed evaluation of asphalt-treated materials.

This report describes a study which was undertaken to evaluate the effects of seven factors on the tensile properties of asphalt-treated materials. The seven factors investigated were aggregate type, aggregate gradation, asphalt cement type, asphalt content, mixing temperature, compaction temperature, and curing temperature. The test responses discussed are elastic tensile strain, modulus of elasticity, Poisson's ratio, total tensile strain, and tensile strength.

The results of analysis of variance are included in the report and indicate the significant main effects, interactions, and quadratic effects (non-linear) for each of the test responses. Regression analyses were conducted on those main effects and interactions which were considered to be of practical engineering significance to obtain prediction equations for modulus of elasticity, Poisson's ratio, tensile strength, and tensile strains in terms of the seven independent variables. These prediction equations were used to estimate

values of the material characterization constants for a variety of levels of the seven independent variables. The estimated values are presented in tabular form and in sets of curves which can be used to readily obtain estimates of modulus of elasticity, Poisson's ratio, tensile strength, and failure strains for a variety of asphalt-treated materials.

KEY WORDS: modulus of elasticity, Poisson's ratio, tensile strength, tensile strain at failure, asphalt, aggregate, gradation, asphalt cement type, mixing temperature, compaction temperature, curing temperature, indirect tensile test, subbase, asphalt stabilization.

## SUMMARY

The purpose of this report is to summarize the findings from a detailed investigation concerned with establishing the important factors affecting the tensile properties of asphalt-treated materials and developing predictive equations for estimating these properties. Included among the properties investigated were modulus of elasticity, Poisson's ratio, tensile strength, and tensile strains at failure. Five of the seven factors, aggregate gradation, asphalt cement type, mixing temperature, compaction temperature, and curing temperature, were investigated at three levels and asphalt content was investigated at five levels in a statistically designed experiment to obtain detailed information on the effects produced by these factors.

Five of the factors, aggregate type, aggregate gradation, asphalt cement type, asphalt content, and compaction temperature, significantly affected the modulus of elasticity and tensile strength either directly or by interrelated effects produced by one or more of the factors.

In addition, four of the factors, aggregate type, asphalt cement type, asphalt content, and compaction temperature, significantly affected the material strain at failure while only four of them, aggregate type, aggregate gradation, asphalt content, and compaction temperature, significantly affected Poisson's ratio.

In the analysis for all five material properties, it was found that one or more of the seven factors interact with each other so that the actual effect produced by changing one variable is dependent on the levels of the other involved variables.

Prediction equations were also developed for estimating modulus of elasticity, Poisson's ratio, tensile strength, and tensile failure strains for any combination of the given factor levels. These prediction equations were used to estimate values of the material properties for a variety of levels of the seven factors. The estimated values are presented in tabular form and in sets of curves which can readily be used to obtain estimates of modulus of elasticity, Poisson's ratio, tensile strength, or tensile failure strains for a variety of asphalt-treated materials.



The data from this study indicated that there was no trend or correlation between either modulus of elasticity and density or tensile strength and density. Hence, changes in density alone cannot be used as a measure of changes in tensile properties of asphalt-treated materials, but must be accompanied by careful consideration of the factors involved in the mix design.

Because of the dominant effect of compaction temperature on the three tensile properties, it is recommended that (1) present laboratory test procedures be extended to include the evaluation of the effect of changes in compaction temperature and (2) closer control of compaction temperature in the field be established through specification requirements.

## IMPLEMENTATION STATEMENT

This study is part of a program to provide a better understanding of the behavior and performance of asphalt-treated materials used in a pavement structure. The results will be used in the repeated loading phase of the study and will also form a major portion of the subbase design procedure. The detailed findings relating the effects of individual factors and their interactions on the tensile properties of asphalt-treated materials can be used to establish those factors which will be important in the development of a design procedure.

Since there are optimum values indicated in the plots of the relationship between the important factors and the modulus of elasticity and tensile strength, the indirect tensile test can be used to establish an optimum asphalt content for asphalt-treated subbase materials. Thus, mix design procedures based upon the tensile properties of asphalt-treated materials can be developed and could be of benefit to the Texas Highway Department. The set of curves presented in the report can be used to augment and/or upgrade the existing mix design techniques by estimating the optimum asphalt content for a particular set of factors based upon tensile properties of the mix.

The dominant effect of compaction temperature on all five of the material properties is indicated in the plots where decreases in the compaction temperature produce corresponding decreases in the modulus of elasticity and tensile strength and increases in Poisson's ratio and tensile strains at failure. This indicates that closer control of the compaction temperature through specification requirements could produce mixture properties closer to those obtained in the lab and could substantially increase the uniformity of the stabilized mixtures along the length of the highway.

TABLE OF CONTENTS

PREFACE . . . . . iii

LIST OF REPORTS . . . . . iv

ABSTRACT . . . . . vi

SUMMARY . . . . . viii

IMPLEMENTATION STATEMENT . . . . . x

CHAPTER 1. INTRODUCTION . . . . . 1

CHAPTER 2. EXPERIMENTAL PROGRAM

    Current Status of Knowledge . . . . . 2

    Selection of Factors . . . . . 4

    Independent Variables Evaluated . . . . . 6

    Preparation and Testing Procedure . . . . . 9

    Statistical Design and Analysis . . . . . 9

CHAPTER 3. ANALYSIS

    Analysis of Variance . . . . . 11

    Regression Analysis . . . . . 19

    Discussion of Results . . . . . 30

CHAPTER 4. SUMMARY AND CONCLUSIONS . . . . . 56

REFERENCES . . . . . 59

APPENDIX 1. SUMMARY OF TEST DATA FOR ASPHALT CEMENT . . . . . 61

APPENDIX 2. DISCUSSION OF INDIRECT TENSILE TEST AND TECHNIQUES  
FOR ESTIMATING TENSILE PROPERTIES . . . . . 63

APPENDIX 3. PHASING ANALYSIS AND EXPERIMENTAL ERROR EVALUATION . . . . . 87

THE AUTHORS . . . . . 98

## CHAPTER 1. INTRODUCTION

The increased use of asphalt-treated subbases in rigid pavement structures has created the need for a rational structural design procedure for the various layers within the pavement. A structural design procedure based upon layered theory is presently under development at The University of Texas at Austin (Ref 1) to satisfy this need. This theoretical design method requires that material characterization constants such as modulus of elasticity, Poisson's ratio, and failure strain be estimated for materials used in the various layers.

In previous work (Ref 2) the tensile strengths for asphalt-treated materials were evaluated over a wide variety of qualitative and quantitative factors in a quarter fractional factorial design. That particular study provided insight into the complexity of effects produced by various factors and indicated that the actual effect produced by changes in one factor is highly dependent on the changes that occurred in two or more other factors which might vary. The study, however, was limited primarily to the evaluation of the effects of eight factors on the tensile strength of the materials.

Subsequent to that study a technique (Ref 3) for estimating the material characterization constants of modulus of elasticity, Poisson's ratio, and tensile failure strains was developed which would allow for a detailed evaluation of the tensile characteristics of asphalt-treated materials.

This study was undertaken for two primary reasons:

- (1) to provide a detailed look at the nonlinear effects of all quantitative variables, including several different asphalt contents, on the tensile properties of asphalt-stabilized materials; and
- (2) to produce predictive equations for all tensile properties in terms of a variety of independent variables.

In addition an evaluation was conducted to investigate the possibility of different experimental errors associated with the three phases in specimen preparation and testing, i.e., mixing, compaction, and curing phases. The results of this evaluation were used to establish the type of analysis required and to indicate which phase required closer experimental control.

## CHAPTER 2. EXPERIMENTAL PROGRAM

### CURRENT STATUS OF KNOWLEDGE

An abundance of information concerning factors affecting the strength characteristics of asphalt-treated materials is available in the literature. The more important factors have been determined using a variety of different test methods including stability tests, flexural tests, and bearing tests as well as shear tests. Hadley et al (Ref 2) in a literature review found that some of the most significant factors affecting asphalt-treated materials were

- (1) characteristics of aggregate,
- (2) gradation of aggregate,
- (3) asphalt content,
- (4) asphalt cement type,
- (5) compactive effort,
- (6) mixing temperature effects,
- (7) compaction temperature effects,
- (8) curing temperature effects,
- (9) loading rate, and
- (10) repeated loading.

Eight of these factors were selected as probably being the more important ones and a preliminary experiment involving two levels of the eight factors was conducted utilizing a quarter fractional factorial design. The purpose of the experiment was to study the effect of the eight factors listed in Table 1 on the indirect tensile strength of asphalt-treated materials and the experiment was designed to evaluate the significant effects produced by all eight factors and the interaction effects involving two or more of the factors. The conclusions from this preliminary study were as follows:

- (1) There were a number of main effects (six) and interactions (twelve two-way and three three-way) which significantly affected the tensile strength of asphalt-treated materials and which were considered to be of practical significance to the engineer. This illustrated the complexity of the relationship between tensile strength and a number of independent variables.

TABLE 1. FACTORS AND LEVELS INVESTIGATED IN A PRELIMINARY EXPERIMENT

Factor	Levels	
	Low	High
Aggregate type	Crushed limestone	Seguin gravel
Aggregate gradation	Fine	Coarse
Asphalt cement type	AC-5	AC-20
Asphalt content	3.5%	7.0%
Compaction type	Impact	Gyratory shear
Mixing temperature	250° F	350° F
Compaction temperature	200° F	300° F
Curing temperature	40° F	110° F

- (2) It is not adequate to assign causes to a specific combination of factors based only on main effects since there were a number of interactions which were important in establishing the tensile strength. Thus, consideration must be given to interaction effects in predicting the value of the particular property.
- (3) In general, it was found that tensile strength was increased by
  - (a) increasing the asphalt content from 3.5 to 7.0 percent,
  - (b) increasing the compaction temperature from 200<sup>o</sup> F to 300<sup>o</sup> F,
  - (c) using impact rather than gyratory shear compaction,
  - (d) increasing the mixing temperature from 250<sup>o</sup> F to 350<sup>o</sup> F,
  - (e) using an AC-20 rather than AC-5 asphalt cement, and
  - (f) using crushed limestone rather than rounded gravel aggregate.
- (4) Asphalt content appeared to have the largest effect on the tensile strength of asphalt-treated materials.

Although the initial study established the important factors affecting indirect tensile strength of asphalt-treated materials and the interrelationships between these factors, it did not provide a detailed evaluation of the nature of the effect since each factor was studied at only two levels. In addition, there was no evaluation of the magnitude of other tensile properties such as modulus of elasticity, Poisson's ratio, and tensile strains. Since information regarding these other properties as well as more detailed information on the nature of the effects produced by factors was needed, it was felt that a more detailed study should be made utilizing the findings from the initial study as a guide.

#### SELECTION OF FACTORS

This experiment was designed to investigate seven different factors considered to affect the tensile properties of asphalt-treated materials. A composite design (Refs 4, 5, and 6) was utilized which allowed the nonlinear effects of six of the seven factors to be investigated. The factors and levels selected for this investigation are summarized in Table 2.

The seven factors included in this study are identical to seven of the eight factors evaluated in the screening experiment (Ref 2). The eighth factor, compaction type, was not included in this present study since

- (1) the gyratory shear compaction method is presently used by the Texas Highway Department for laboratory compaction of hot mix asphaltic materials (Ref 8) and



TABLE 2. FACTORS AND LEVELS SELECTED FOR EXPERIMENTAL PROGRAM

Factor	Description	Levels				
		Lo Low -2	Low -1	Medium 0	Hi +1	Hi High +2
Aggregate type	Qualitative		Crushed limestone		Seguin gravel	
Aggregate gradation <sup>*</sup>	Quantitative		Fine (2 mm)	Medium (4 mm)	Coarse (6 mm)	
Asphalt cement type <sup>**</sup>	Quantitative		AC-5 (8.5)	AC-10 (9.0)	AC-20 (9.7)	
Asphalt content	Quantitative	4.0%	5.5%	7.0%	8.5%	10.0%
Mixing temperature	Quantitative		250 <sup>o</sup> F	300 <sup>o</sup> F	350 <sup>o</sup> F	
Compaction temperature	Quantitative		200 <sup>o</sup> F	250 <sup>o</sup> F	300 <sup>o</sup> F	
Curing temperature	Quantitative		40 <sup>o</sup> F	75 <sup>o</sup> F	110 <sup>o</sup> F	

\* Numbers and units in parentheses refer to the diameter of the particle in millimeters for which 60 percent of the mixture by weight was finer.

\*\* The asphalt cement test results are included in Appendix 1. Numbers in parentheses are the slopes of the log temperature-log viscosity relationship between 140<sup>o</sup> F and 275<sup>o</sup> F.

- (2) compaction type is a qualitative factor and cannot be related directly to field compaction.

The low and high levels for aggregate type, aggregate gradation, asphalt cement type, mixing temperature, compaction temperature, and curing temperature were the same as in the screening experiment.

The gradation curves for the fine, medium, and coarse graded mixtures are presented in Fig 1. The three levels were designated numerically by the diameter of particle for which 60 percent of the total weight of the mixture was finer. The fine, medium, and coarse gradations were identified as 2 mm, 4 mm, and 6 mm particles.

The log temperature-log viscosity relationships for the AC-5, AC-10, and AC-20 asphalt cements are presented in Fig 2. The three levels were specified by the slope of these relationships in the temperature range between 140° F and 275° F and were determined by the equation

$$\text{Slope} = \frac{\log (V_{140}) - \log (V_{275})}{\log (140) - \log (275)} \quad (2.1)$$

where  $V_{140}$  and  $V_{275}$  are the viscosities at 140° F and 275° F, respectively. The AC-5, AC-10, and AC-20 asphalt cements are identified by slopes of 8.5, 9.0, and 9.7, respectively.

The levels for asphalt content were chosen on the basis of the results of the screening experiment so that optimum asphalt content with respect to strength could be obtained. The intermediate levels between 4.0 percent and 10.0 percent provided a measure of the nonlinear effect of asphalt content.

Medium levels were also included in this experiment for the remaining quantitative variables. Aggregate type was a qualitative variable or one in which the different levels could not be arranged in order of magnitude (Ref 5); therefore, a medium level could not be selected for aggregate type.

#### INDEPENDENT VARIABLES EVALUATED

In this study the following tensile characteristics were evaluated:

- (1) tensile strength,
- (2) elastic tensile strain,
- (3) modulus of elasticity,
- (4) Poisson's ratio, and

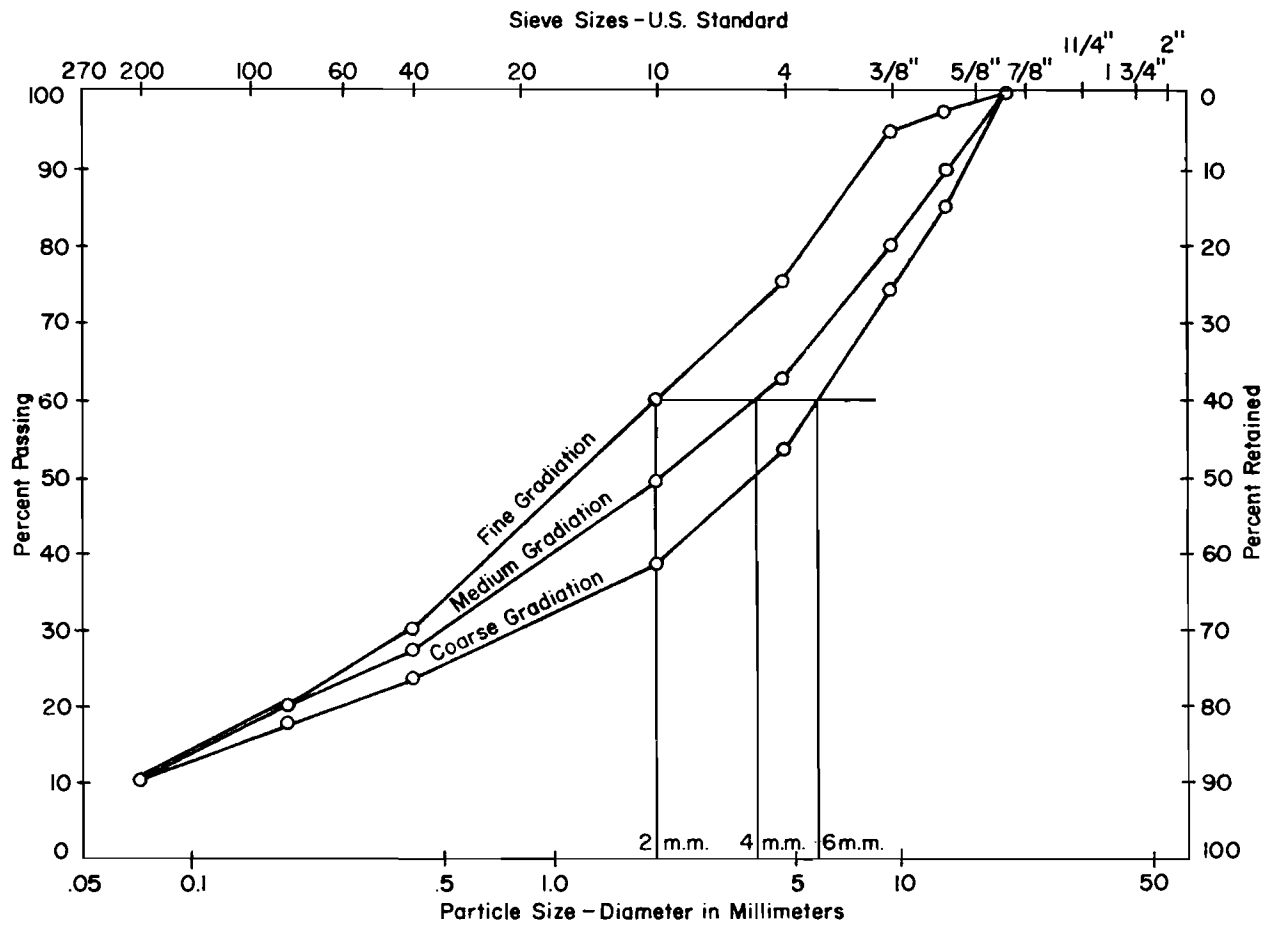

Fig 1. Gradation curves for aggregate mixtures.

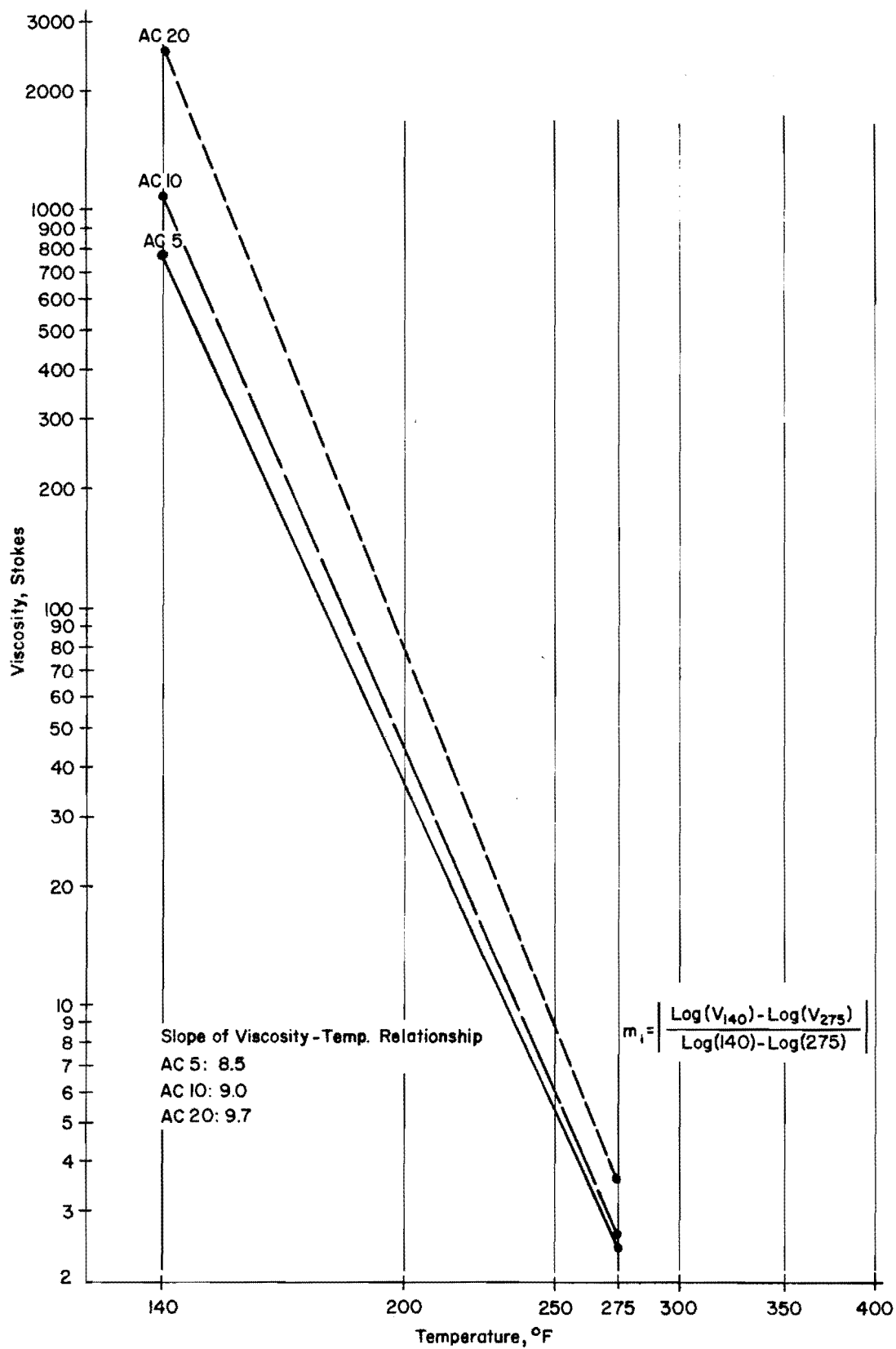

Fig 2. Temperature-viscosity relationship of asphalt cements used in the experiment.

(5) total tensile strain.

Since the indirect tensile test is based on elastic theory, the following assumptions were made. Asphalt-treated materials are homogeneous, isotropic, and elastic in nature and obey Hooke's law. A discussion of the indirect tensile test and the techniques for estimating strength, modulus of elasticity, Poisson's ratio, and tensile strains are included in Appendix 2 and Ref 3. Examples of the method of estimating all five variables are also included in Appendix 2 for two of the specimens evaluated in the present study.

#### PREPARATION AND TESTING PROCEDURE

All asphalt-treated materials were mixed for three minutes and compacted in a Texas gyratory-shear molding press to form a cylindrical specimen with a nominal 4-inch diameter and 2-inch height. The molded specimens were allowed to cool to room temperature and then their densities were determined. The specimens were then cured for 14 days at the designated curing temperature. At the end of the curing period, the specimens were tested in indirect tension at a testing temperature of 75<sup>0</sup> F and at a loading rate of 2.0 inches per minute. The tests were conducted using a set of loading strips with curved portions of radius 2 inches and a width of one-half inch. The test and equipment are discussed in detail in Appendix 2 and Refs 1 and 6.

#### STATISTICAL DESIGN AND ANALYSIS

A central composite rotatable design was used in investigating the asphalt-treated materials. The design consisted of a 2<sup>7</sup> full factorial with 128 possible combinations of the seven factors, which allowed the effects of all seven factors and their interactions to be evaluated, and 48 wall points and four center points, which allowed curvilinear effects to be evaluated. Because of time limitations the full factorial experiment was conducted in two parts consisting of complementary half-fractions. Each half-fraction plus curvature points contained 96 specimens, approximately the maximum number of specimens which could be mixed in 18 hours. A third half-fraction, which was identical to one of the original half-fractions, was included in the study in order to check for the effect of the three phases, mixing, compaction, and curing, on experimental error.

The complete analysis consisted of a phasing analysis and experimental error evaluation (Appendix 3) and an analysis of variance and a regression analysis (Chapter 3). The experimental error evaluation and phasing analysis were completed first in order to establish the type of analysis to be used in subsequent analyses. These two analyses are included in Appendix 3.

## CHAPTER 3. ANALYSIS

The analysis of the data consisted of an analysis of variance and a regression analysis. The analysis of variance was utilized to identify those factors and interactions which should be considered in the regression analysis while the regression analysis was used to approximate the functional relationship between the tensile characteristics and the factors involved in preparing and placing an asphalt-treated material which could be used for estimating the various tensile characteristics. The observed effects and their causes are considered in terms of the results of the regression analysis.

### ANALYSIS OF VARIANCE

The results of the phasing analysis (Appendix 3) indicated that the data from this study should be analyzed assuming a completely randomized design; therefore the analysis of variance consists of an evaluation of the effects produced by the various factors and their interactions for each of the dependent variables, i.e., tensile strength, modulus of elasticity, Poisson's ratio, and tensile strains.

An analysis of variance is a technique for estimating how much of the total variation in some dependent variable can be attributed to assigned changes in the levels of the independent variables, i.e., aggregate type, gradation, etc. A decision as to whether or not these changes in the independent variables have resulted in real variations can be made by comparing these variations with the expected experimental error variation.

The results of the analysis of variance including quadratic effects are presented in Tables 3 through 7 for tensile strength, total tensile strain at failure, modulus of elasticity, Poisson's ratio, and elastic tensile strain at failure. As shown in these tables, there were a number of factors and interactions which had a significant effect on the various tensile characteristics. However, not all of these effects had practical significance. In other words, these effects, although measurable, were not large and probably would make no effective difference in the applications of the results. The trends and causes

TABLE 3. ANALYSIS OF VARIANCE FOR TENSILE STRENGTH

<u>Source of Variation*</u>	<u>Degree of Freedom</u>	<u>Mean Squares</u>	<u>F Value</u>	<u>Significance Level, %</u>
BD	1	137615	299.80	.5
G	1	105580	230.01	.5
D	1	59391	129.39	.5
Dq (Quadratic)	1	45525	99.18	.5
C	1	29900	65.14	.5
BDG	1	16199	35.29	.5
Bq (Quadratic)	1	15185	33.08	.5
ABD	1	14699	32.02	.5
B	1	12368	26.94	.5
Experimental error	79	459.0		

\* Single letters indicate main effects and multiple letters indicate interaction or quadratic effects.

#### Legend

- A - Aggregate type
- B - Aggregate gradation
- C - Asphalt cement type
- D - Asphalt content
- F - Mixing temperature
- G - Compaction temperature
- H - Curing temperature
- q - Quadratic effect



TABLE 4. ANALYSIS OF VARIANCE FOR TOTAL TENSILE STRAIN AT FAILURE

<u>Source of Variation</u>	<u>Degree of Freedom</u>	<u>Mean (<math>\times 10^{-6}</math>) Squares</u>	<u>F Value</u>	<u>Significance Level, %</u>
G	1	3.133	19.06	.5
AD	1	1.723	10.48	.5
D	1	1.307	7.95	1
A	1	.901	5.48	2.5
Experimental error	64	0.1644		

Legend

- A - Aggregate type
- B - Aggregate gradation
- C - Asphalt cement type
- D - Asphalt content
- F - Mixing temperature
- G - Compaction temperature
- H - Curing temperature

TABLE 5. ANALYSIS OF VARIANCE FOR MODULUS OF ELASTICITY

<u>Source of Variation</u>	<u>Degree of Freedom</u>	<u>Mean Squares</u>	<u>F Value</u>	<u>Significance Level, %</u>
BD	1	103.2	191.33	.5
G	1	75.0	139.10	.5
D	1	48.4	89.77	.5
C	1	20.3	37.73	.5
Dq (Quadratic)	1	20.3	37.61	.5
BDG	1	18.8	34.91	.5
Bq (Quadratic)	1	12.4	22.99	.5
ABD	1	6.5	11.99	.5
A	1	5.1	9.50	.5
Experimental error	79	0.539		

Legend

- A - Aggregate type
- B - Aggregate gradation
- C - Asphalt cement type
- D - Asphalt content
- F - Mixing temperature
- G - Compaction temperature
- H - Curing temperature
- q - Quadratic effects

TABLE 6. ANALYSIS OF VARIANCE FOR POISSON'S RATIO

<u>Source of Variation</u>	<u>Degree of Freedom</u>	<u>Mean Squares</u>	<u>F Value</u>	<u>Significance Level, %</u>
G	1	.486	29.45	.5
AD	1	.283	17.15	.5
D	1	.260	15.76	.5
AB	1	.126	7.64	1
Experimental error	79	.0165		

Legend

A - Aggregate type

B - Aggregate gradation

C - Asphalt cement type

D - Asphalt content

F - Mixing temperature

G - Compaction temperature

H - Curing temperature

TABLE 7. ANALYSIS OF VARIANCE - ELASTIC TENSILE STRAIN  
AT FAILURE

<u>Source of Variation</u>	<u>Degree of Freedom</u>	<u>Mean Squares</u>	<u>F Value</u>	<u>Significance Level, %</u>
D	1	197.8	65.27	.5
G	1	159.0	52.47	.5
A	1	42.1	13.89	.5
AD	1	26.0	8.58	.5
ACG	1	21.9	7.23	1
Experimental error	79	3.03		

Legend

- A - Aggregate type
- B - Aggregate gradation
- C - Asphalt cement type
- D - Asphalt content
- F - Mixing temperature
- G - Compaction temperature
- H - Curing temperature

behind the significant main effects and interactions are presented in the discussion of results.

### Tensile Strength

The tensile strengths obtained in this study varied from 10 to 268 psi with the majority in the range of 50 to 200 psi. Those main effects and interactions which had significant effects on the indirect tensile strength at a level of 0.5 percent are presented in Table 3. This probability level, as in the case of the modulus of elasticity evaluation, was considered to indicate those effects and interactions which had practical engineering significance and were important in engineering application of the results. It is important to note that the first eight effects and interactions in the analysis of variance for tensile strength (Table 3) are the same as in the analysis of variance for modulus of elasticity (Table 5), therefore indicating a strong possibility of correlation between the two responses. The only difference is that the positions of Factor C, asphalt cement type, and the quadratic effect due to asphalt content  $D_q$  are reversed in the two tables. In addition aggregate gradation is important, not only in terms of its influence on the effects produced by other factors but also in terms of the effect produced by itself. The important factors to consider were

- (1) compaction temperature,
- (2) asphalt content,
- (3) asphalt cement type,
- (4) aggregate gradation, and
- (5) aggregate type.

### Total Tensile Strain at Failure

The total tensile strains at failure ranged from 0.00045 to 0.0027. There were three main effects and one two-way interaction which were considered to have practical engineering significance. The analysis of variance for these four effects, which were significant at a probability level of 2.5 percent, are presented in the summary of the analysis of variance (Table 4). The important factors as shown in this table were

- (1) compaction temperature,
- (2) asphalt content, and
- (3) aggregate type.

### Modulus of Elasticity

Modulus of elasticity values ranged from about 17,500 to 735,600 psi with the majority of the moduli in the range of 100,000 to 400,000 psi. In terms of engineering application, it was judged that practical significance corresponded with an 0.5-percent probability level. Thus, only those main effects and interactions significant at that probability level were considered to have practical meaning. As shown in Table 5, the following factors were important and should be considered in the design and estimation of modulus values for asphalt-treated materials

- (1) compaction temperature,
- (2) asphalt content,
- (3) asphalt cement type,
- (4) aggregate type, and
- (5) aggregate gradation.

Aggregate gradation did not produce a significant effect by itself but did significantly influence the effect produced by most of the other factors.

### Poisson's Ratio

Most of the values for Poisson's ratio varied between 0.10 and 0.45; however, there were two values which exceeded 0.5 and several values which approached 0.0. These high and low values of Poisson's ratio are probably the result of random testing error or of using elastic theory to characterize a nonelastic material. There were only a limited number of factors and interactions which had significant influence on the Poisson's ratio values. In fact, there were only three main effects, four two-way interactions and one three-way interaction significant at the 10.0 percent level. More important, however, only two main effects and two two-way interactions were considered of practical engineering significance, which corresponded to a probability level of 1 percent (Table 6). The important factors were

- (1) compaction temperature,
- (2) asphalt content,
- (3) aggregate type, and
- (4) aggregate gradation.

The latter two were important only in terms of their influence on the effects produced by the other factors.

#### Elastic Tensile Strain at Failure

The portion of the total strain at failure which could be considered to be elastic ranged from .00032 to .00138. The summary of the analysis of variance for those main effects and interactions of practical engineering significance (probability level of 1.0 percent) presented in Table 7. The important factors were

- (1) asphalt content,
- (2) compaction temperature,
- (3) aggregate type, and
- (4) asphalt cement type.

#### REGRESSION ANALYSIS

The functional relationship which exists between a dependent variable and a number of independent variables is usually too complicated to describe in simple terms. If no prior knowledge of the form of the functional relationship exists, then an approximation of the function can be made by a polynomial which contains the appropriate variables and which is valid over some limited ranges of the variables involved (Ref 9).

The approach used in this study was to approximate the functional relationship between the dependent and independent variables by a polynomial containing the main effects, quadratic effects, and interaction effects which were found to be significant by the analysis of variance. The assumed polynomial included all seven main effects, all quadratic effects for the factors except aggregate type, and all possible interactions up to and including three-way interactions.

A stepwise regression computer program was then used to develop prediction equations by regression analysis. This technique fits a curve to a set of data points in such a way that the summation of the squares of the difference between the actual value and the estimated value of the response variable is minimized.

### Discussion of Results of the Regression Equation

There were several indicators and tests used to evaluate the prediction capability of the regression equations. These indicators included the multiple correlation coefficient, coefficient of determination, coefficient of variation, and standard error of estimate. The multiple correlation coefficient, which is generally denoted as  $R$ , is a measure of the linearity of the fit between the data and regression equation, while the coefficient of determination or  $R^2$  indicates that portion of the total variation in the response variable which can be explained by the regression equation. The coefficient of variation is an indicator of the relative variation which can be expected and is determined from the equation

$$CV = \frac{\hat{S}_e}{\bar{Y}} \times 100$$

where  $\bar{Y}$  is the overall mean of the response  $Y$ , and  $\hat{S}_e$  is the standard deviation of the errors of estimation or the square root of the experimental error variance. The standard error of estimate  $\hat{S}_r$  is the standard deviation of the errors of estimation; under certain conditions approximately two-thirds of the actual data will fall within one standard error of the estimated value. In addition, under the same conditions, approximately 95 percent of the data will fall within a region bounded by two lines drawn parallel to the line of regression at a distance of  $1.96 \hat{S}_r$ .

The regression equation can also be evaluated by checking for lack of fit. The test essentially consists of comparing the residual mean squares with the experimental error variance. The residual mean square is that portion of the total variation of a response which has not been attributed to a given cause, i.e., that portion unexplained by the terms included in the model. If the model is correct or fits the data, then the residuals contain only random variation which approximately equals the experimental error variation. However, if the model is not correct, the residuals contain systematic as well as random variations and will be larger than the experimental error. The  $F$  significance test then can indicate at some probability level ( $\alpha = .01$  in this study) whether or not the regression equation properly explains the variation in the response variable.



The values of the indicators discussed above as well as the results of the test for lack of fit are included in Table 8. Each regression equation is evaluated in terms of these indicators in the following paragraphs.

### Regression Equations

The centered-data technique (Ref 10) was used in this study to develop regression equations by the stepwise regression technique. The terms included in each of the equations correspond to those factors and their interactions found to be of practical engineering significance in the analysis of variance. The resulting equations can provide estimates of the various dependent parameters measured in the study within some standard error. Included with the equations are the standard errors of estimate  $\hat{S}_r$  and the coefficient of determination  $R^2$ . The terms  $A_i$ ,  $B_i$ ,  $C_i$ ,  $D_i$ ,  $G_i$ , and  $H_i$  are the levels of the various factors used in the experiment (see Table 8).

(1) Tensile strength, psi

$$\begin{aligned}
 S_T = & 150.8 - 5.027(B_i - 4.0) + 26.037(C_i - 9.1) - 12.691(D_i - 7.0) \\
 & + .574(G_i - 250.0) - 10.929(B_i - 4.0)(D_i - 7.0) \\
 & + 3.572(A_i - 1.0)(B_i - 4.0)(D_i - 7.0) - .0688(B_i - 4.0)(G_i - 250.0) \\
 & - .0750(B_i - 4.0)(D_i - 7.0)(G_i - 250.0) - 3.2775(B_i - 4.0)^2 \\
 & - 11.545(D_i - 7.0)^2
 \end{aligned}$$

$$\hat{S}_r = \pm 28 \text{ psi}$$

$$R^2 = 0.78$$

The relationship between the actual and estimated values of tensile strength is shown in Fig 3 and indicates that the polynomial relationship developed by the regression analysis is adequate. In addition, based upon the

TABLE 8. LEVELS OF FACTORS USED IN REGRESSION EQUATIONS

<u>Factor</u>	<u>Description</u>	<u>Level</u>
A - Aggregate type	Limestone	A(-1) = 0
	Seguin gravel	A(+1) = 2
B - Aggregate gradation*	Fine	B(-1) = 2
	Medium	B(0) = 4
	Coarse	B(+1) = 6
C - Asphalt cement type*	AC-5	C(-1) = 8.5
	AC-10	C(0) = 9.0
	AC-20	C(+1) = 9.7
D - Asphalt content	Lo-low	D(-2) = 4.0
	Low	D(-1) = 5.5
	Medium	D(0) = 7.0
	High	D(+1) = 8.5
	Hi-high	D(+2) = 10.0
F - Mixing temperature	Low	F(-1) = 250
	Medium	F(0) = 300
	High	F(+1) = 350
G - Compaction temperature	Low	G(-1) = 200
	Medium	G(0) = 250
	High	G(+1) = 300
H - Curing temperature	Low	H(-1) = 40
	Medium	H(0) = 75
	High	H(+1) = 110

\*See Figs 1 and 2 for method of determining levels for these two factors.

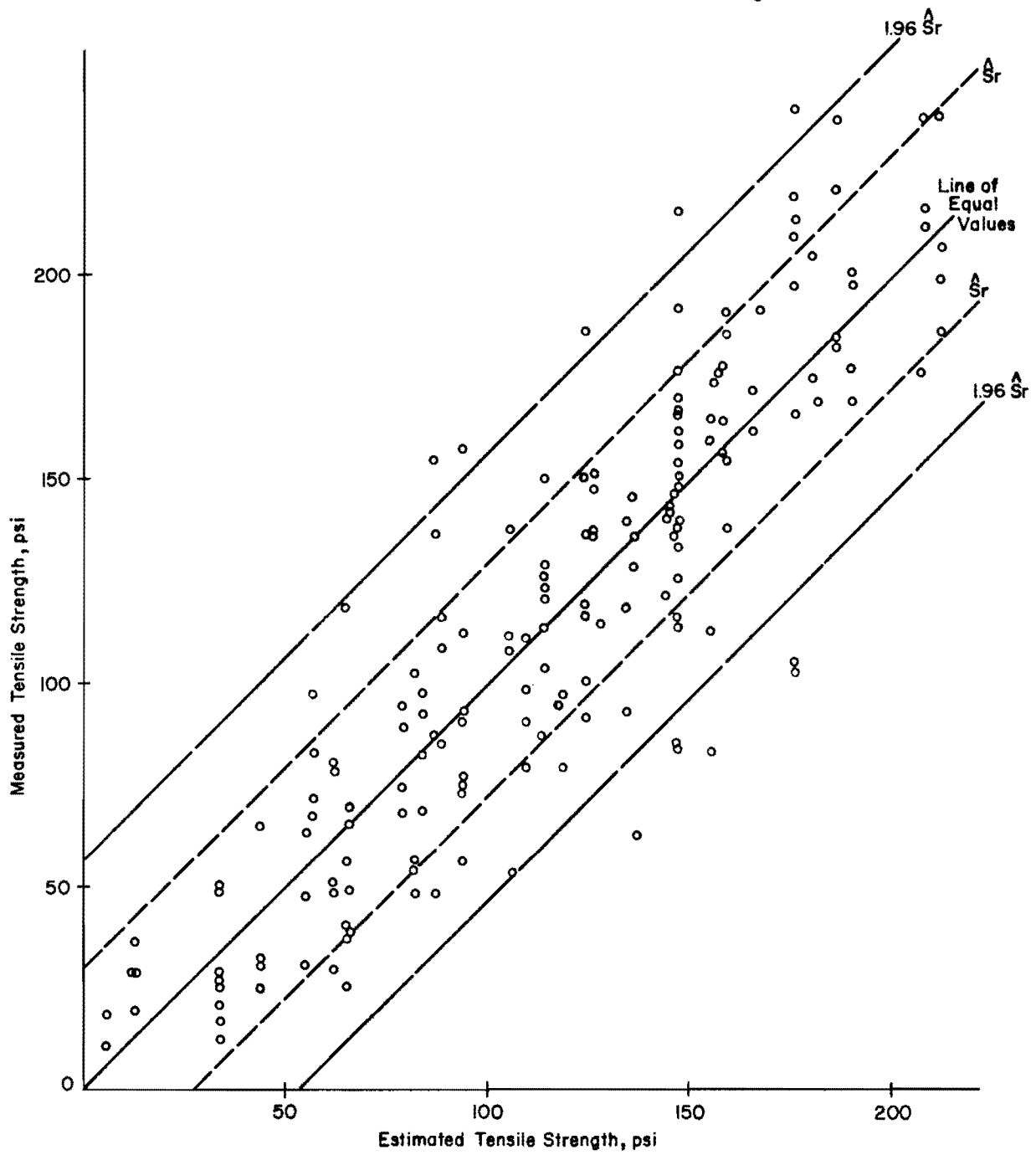

Fig 3. Scatter diagram for tensile strength.

indicators for this parameter (Table 9) the prediction capability of the regression equation was considered to be adequate. A review of the equation shows that only five of the seven variables were included. These variables were aggregate type (Factor A), aggregate gradation (Factor B), asphalt cement type (Factor C), asphalt content (Factor D), and compaction temperature (Factor G).

(2) Total tensile strain, microunits

$$\begin{aligned} \epsilon_T = & 1372.0 + 96.28(A_i - 1.0) + 63.60(D_i - 7.0) \\ & - 3.147(G_i - 250.0) + 63.563(A_i - 1.0)(D_i - 7.0) \end{aligned}$$

$$\hat{S}_r = \pm 318 \text{ microunits}$$

$$R^2 = 0.31$$

The relationship between measured and estimated tensile strain at failure (Fig 4) and the information contained in Table 9 indicate that the regression equation for total tensile strain was questionable; however, lack of fit was not significant. The equation includes the three factors of aggregate type (Factor A), asphalt content (Factor D), and compaction temperature (Factor G). There are two alternatives. Either use the overall mean value of 1370 microunits as an estimate of the total tensile strain at failure, or use the regression equation with the reservation that only about 31 percent of the variation is explained by the terms in the equation. The second alternative is suggested since the factors included in the equation produced significant engineering effects.

(3) Modulus of elasticity, at  $10^5$  psi

$$\begin{aligned} E = & (3.531 - .248)(A_i - 1.0) + 0.6605(C_i - 9.1) \\ & - .3646(D_i - 7.0) + .01523(G_i - 250.0) - .2993(B_i - 4.0) \end{aligned}$$

TABLE 9. PARAMETERS FOR EVALUATING REGRESSION EQUATIONS

Response Variation	Correlation Coefficient R	Coefficient of Determination $R^2$	Coefficient of Variation CV	Standard Error of Estimate	Residual		Experiment Error		$F_a$ Ratio Col 6/ Col 8	Critical F ( $F_{cr}$ )	Sig. Lack of Fit
					Mean Squares	df	Variance	df			
Modulus of elasticity	.8536	0.7286	20.8%	$\pm 0.853 \times 10^5$	$0.763 \times 10^{10}$	144	$0.539 \times 10^{10}$	26	1.416	2.22	No
Poisson's ratio	0.5461	0.2982	69.0%	$\pm .1247$	.0154	149	.0165	26	0.933	2.22	No
Tensile strength	0.8845	0.7823	14.2%	$\pm 28.0$	844.06	143	459.02	26	1.839	2.22	No
Total tensile strain at failure	0.5564	0.3096	29.5%	$\pm 318$	$.090 \times 10^{-6}$	149	$0.164 \times 10^{-6}$	26	0.549	2.22	No
Estimated elastic tensile strain at failure	0.7274	0.5291	22.9%	$\pm 168$	$2.798 \times 10^{-8}$	146	$3.030 \times 10^{-8}$	26	0.923	2.22	No

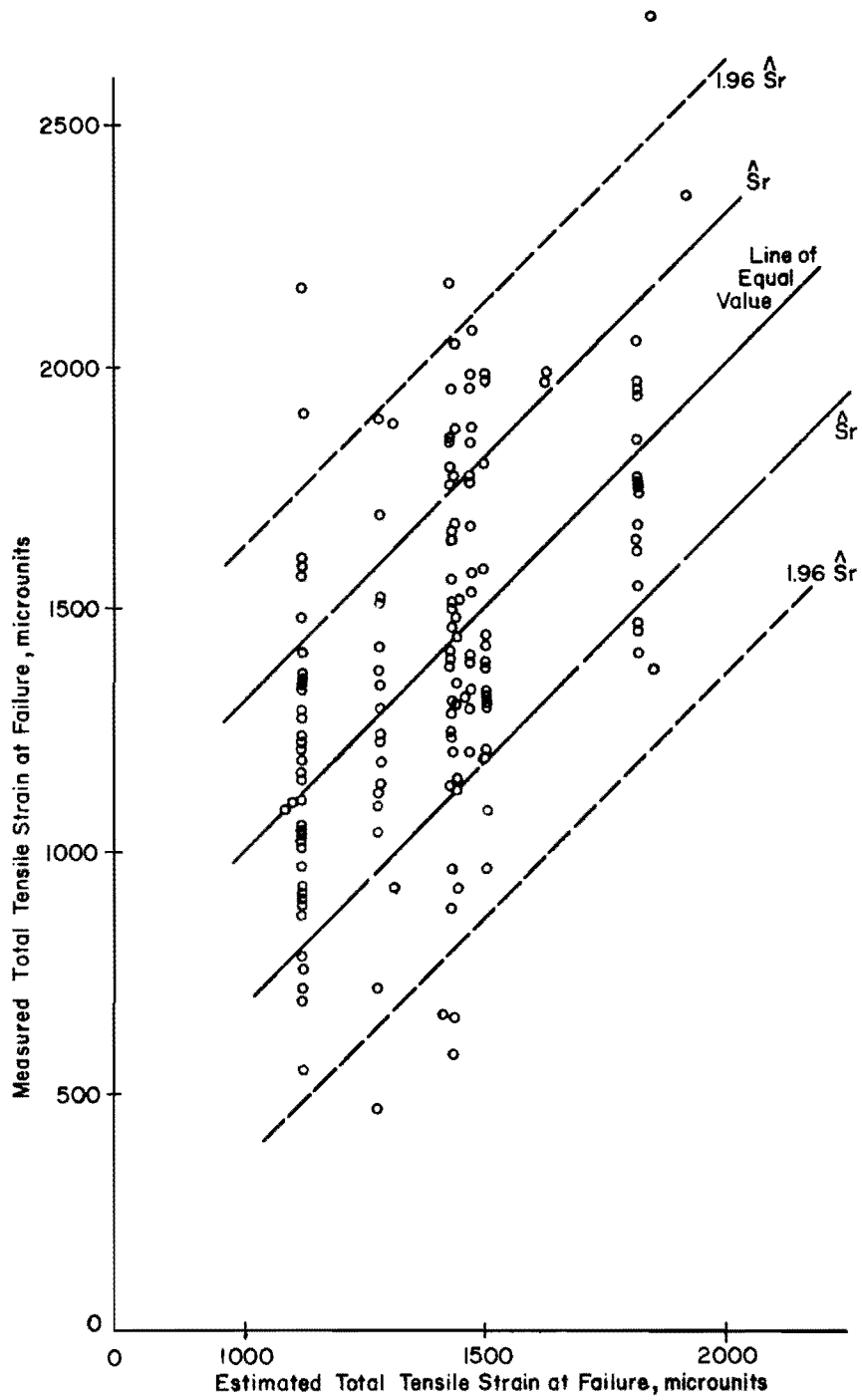

Fig 4. Scatter diagram for total tensile strain at failure.

$$\begin{aligned}
& (D_i - 7.0) + .07491(A_i - 1.0)(B_i - 4.0)(D_i - 7.0) \\
& - .002557(B_i - 4.0)(D_i - 7.0)(G_i - 250.0) - .09857(B_i - 4.0)^2 \\
& - .2570(D_i - .2570)(D_i - 7.0)^2 \\
\hat{S}_r & = \pm 0.853 \times 10^5 \text{ psi}
\end{aligned}$$

$$R^2 = 0.73$$

The regression equation for modulus of elasticity is considered to be adequate for prediction purposes based upon the scatter diagram shown in Fig 5 and the results summarized in Table 9. The variables included in the equation were aggregate type (Factor A), aggregate gradation (Factor B), asphalt cement type (Factor C), asphalt content (Factor D), and compaction temperature (Factor G).

(4) Poisson's ratio

$$\begin{aligned}
v & = 0.2074 + .0246(D_i - 7.0) - .001258(G_i - 250.0) \\
& + .01476(A_i - 1.0)(B_i - 4.0) + .02802(A_i - 1.0)(D_i - 7.0)
\end{aligned}$$

$$\hat{S}_r = \pm 0.125$$

$$R^2 = 0.30$$

The relationship between measured and estimated Poisson's ratios is shown in Fig 6 and indicates a significant amount of scatter. Similarly, an evaluation of the equation in terms of the parameter in Table 9 indicates that the adequacy of the regression is questionable. On the other hand, lack of fit was not significant. In this case, a decision has to be made concerning the use of the equation. There are two alternatives. The first is to abandon

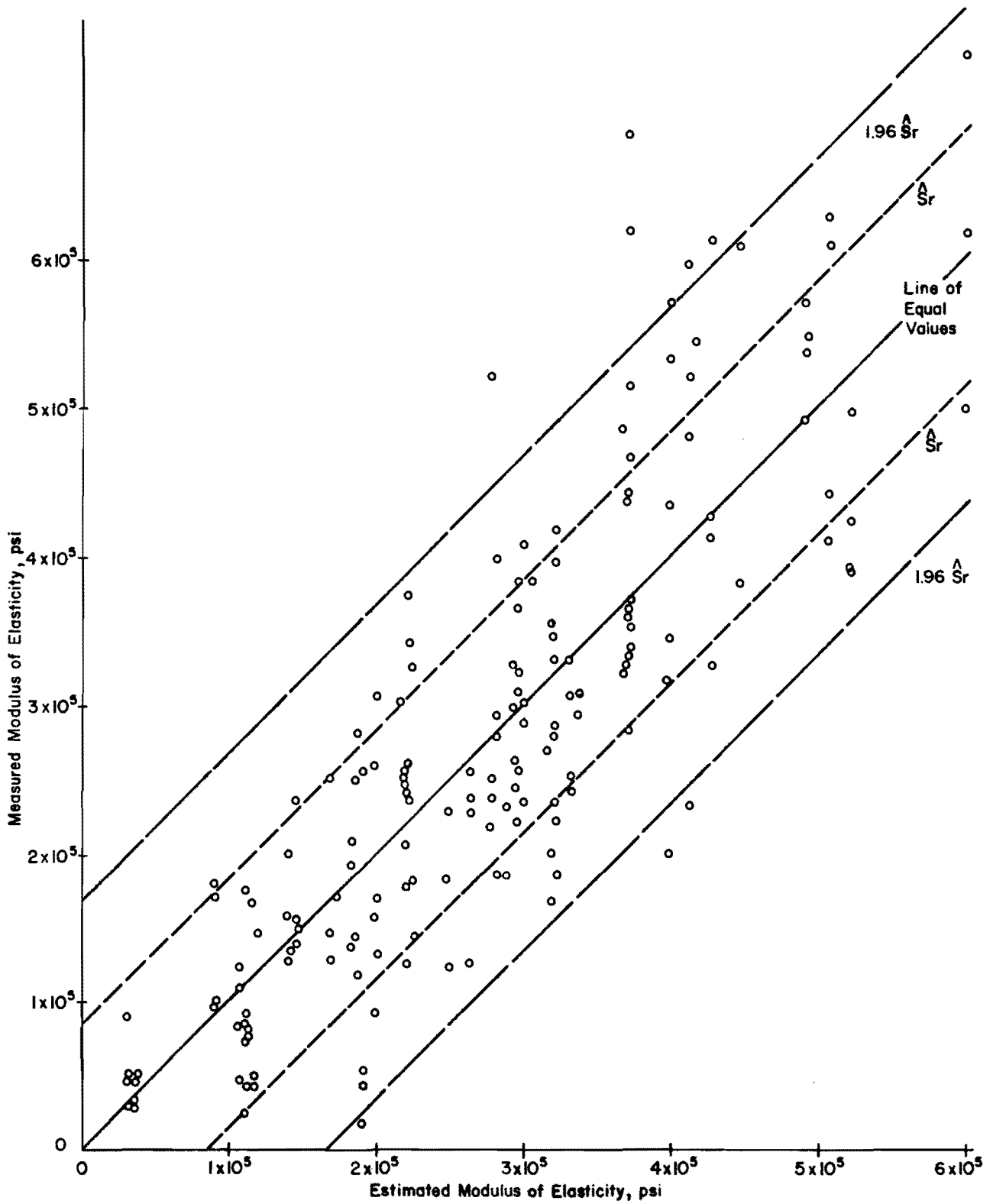

Fig 5. Scatter diagram for modulus of elasticity.



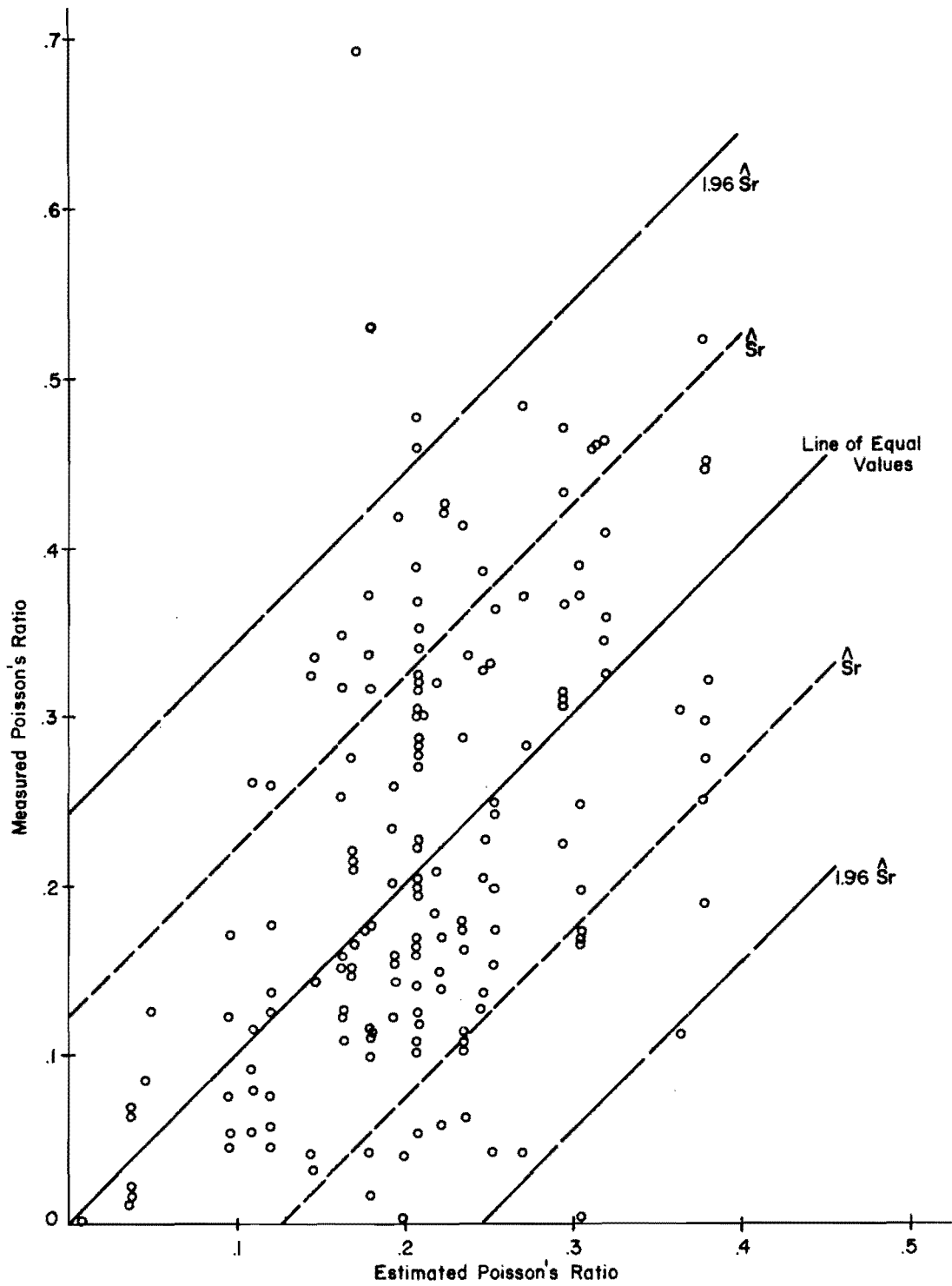

Fig 6. Scatter diagram for Poisson's ratio.

the use of the equation and use the overall mean value as an estimate of the Poisson's ratio. The basic argument for this approach is that since the coefficient of determination  $R^2$  is 0.30, the equation explains only 30 percent of the total variation in Poisson's ratio. The second alternative is to accept the equation with the reservation that there can be substantial variation in Poisson's ratio as evidenced by the relatively large standard error of estimate ( $\hat{S}_r = \pm .125$ ). The primary argument for this second approach is that a better approximation of Poisson's ratio can be obtained than simply using the mean value since there are four effects and interactions which were important. Thus, the individual user must make his own decision; however, it is recommended that the regression equation be used.

(5) Elastic tensile strain, microunits

$$\begin{aligned} \epsilon_E &= 760.5 + 67.0(A_i - 1.0) + 76.98(D_i - 7.0) - 2.21(G_i - 250.0) \\ &\quad + 28.10(A_i - 1.0)(D_i - 7.0) - 1.39(A_i - 1.0)(C_i - 9.1)(G_i - 250.0) \end{aligned}$$

$$\hat{S}_r = \pm 173 \text{ microunits}$$

$$R^2 = 0.49$$

Based on an evaluation of Fig 7 and the indicators in Table 9, it was concluded that the regression equation was adequate. The variables included in the equation are aggregate type (Factor A), asphalt cement type (Factor C), asphalt content (Factor D), and compaction temperature (Factor G). It should be noted that this was the only response for which aggregate gradation was not included.

## DISCUSSION OF RESULTS

### Indirect Tensile Strength (75° F)

The variables included in the equation are aggregate type (Factor A), aggregate gradation (Factor B), asphalt cement type (Factor C), asphalt

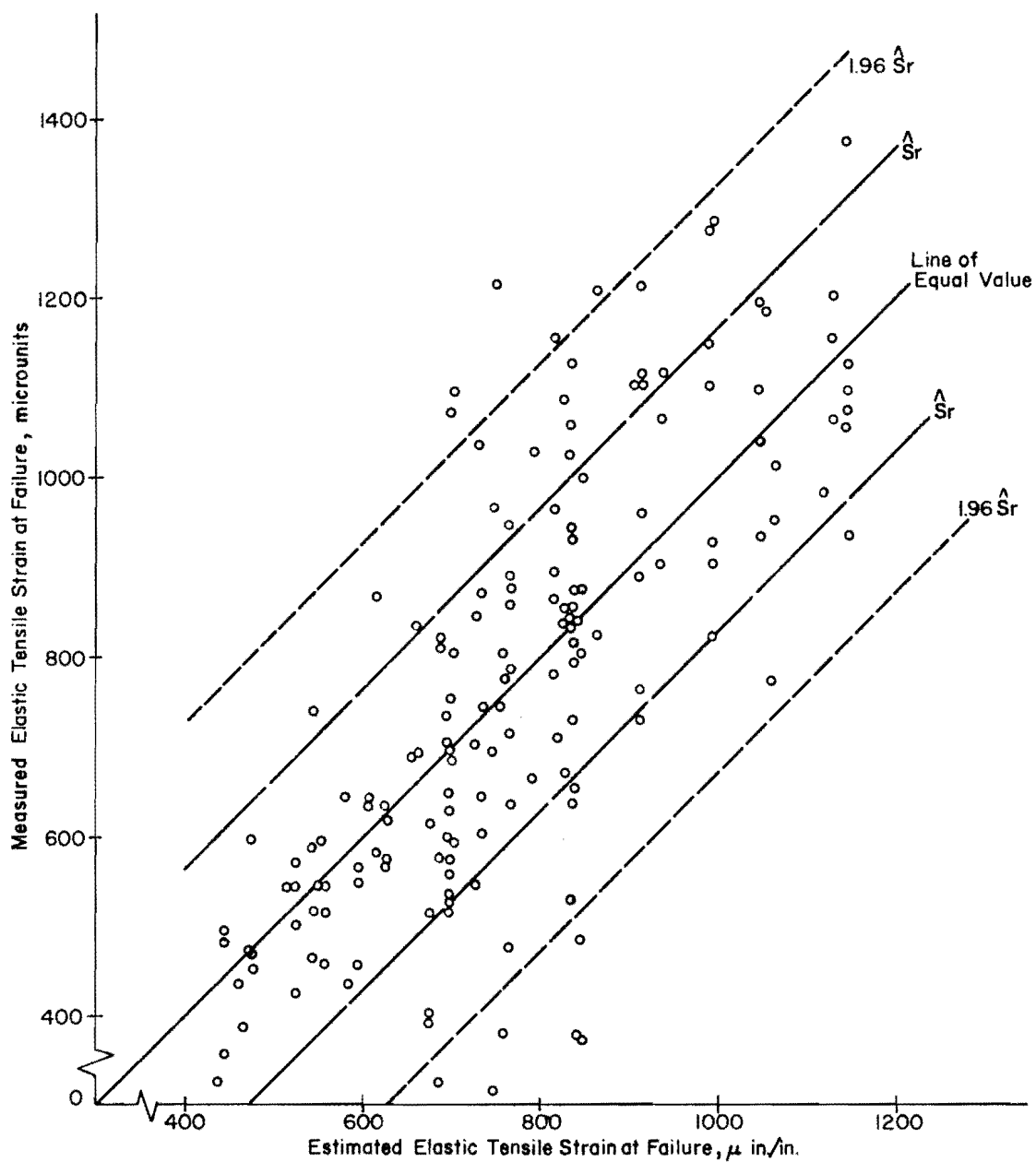

Fig 7. Scatter diagram for elastic tensile strain at failure.

content (Factor D), and compaction temperature (Factor G). Tables 10 and 11 include estimated tensile strengths for different combinations of the five factors. Based upon this table, plots were developed indicating the relationship between asphalt content and compaction temperature for each aggregate at each of the three gradations. These are presented in Figs 8 and 9 for an AC-5 asphalt cement. The effect of asphalt cement type was linear; therefore, the tensile strengths for similar mixtures but with different asphalt cements can be accounted for by adding the proper correction factors to the values obtained from the figures for an AC-5. The correction factors are 13 psi and 31 psi, respectively, for AC-10 and AC-20 asphalt cements.

As shown in Figs 8 and 9 the specimens containing crushed limestone exhibited larger tensile strength than specimens containing gravel. This behavior is attributed to the fact that the angularity, rough surface texture, and porosity of the limestone resulted in a better bond between the aggregate and asphalt.

One of the striking aspects is the pronounced effect of compaction temperature on tensile strength, with high compaction temperatures producing high tensile strengths. In addition, an optimum asphalt content occurred for each gradation of both aggregates; however, this optimum shifted slightly with increasing compaction temperatures for the fine and coarse gradations. For the fine gradations the optimum asphalt content increased with increased compaction temperatures. On the other hand for the coarse gradations, the optimum decreased with increased compaction while for the medium gradation the optimum asphalt content remained essentially constant. It can also be seen that the optimum asphalt content was higher for the specimens containing finer graded aggregates.

There are several hypotheses which can be offered in explanation of these relationships. First of all, higher compaction temperatures produce greater fluidity of the asphalt cement and probably allow movement of the asphalt cement during compaction, thereby producing better distribution of the asphalt in the mixture and creating thinner films of asphalt connecting the aggregate particles.

The optimum asphalt contents for the finer graded mixtures were higher because more asphalt was required to cover the larger surface area associated with finer gradations. In addition the increase in the optimum asphalt content with increased compaction temperatures may be attributed to the fact that with increased fluidity during compaction the distribution of the asphalt is

TABLE 10. ESTIMATED INDIRECT TENSILE STRENGTHS FOR ASPHALT-TREATED LIMESTONE MIXTURES

Asphalt Content, %	Gradation	Asphalt Cement Type								
		Fine			Medium			Coarse		
		AC-5	AC-10	AC-20	AC-5	AC-10	AC-20	AC-5	AC-10	AC-20
200	4.	-	-	-	40.6	53.6	71.8	88.8	101.9	120.0
	4.5	2.3	15.3	33.5	66.0	79.0	97.2	103.5	116.5	134.7
	5.	32.7	45.7	63.9	85.7	98.7	116.9	112.4	125.4	143.6
	5.5	57.3	70.3	88.5	99.5	112.5	130.7	115.5	128.5	146.7
	6.	76.2	89.2	107.4	107.6	120.6	151.8	112.8	125.8	144.0
	6.5	89.2	102.2	120.4	109.9	122.9	141.1	104.4	117.4	135.6
	7.	96.5	109.5	127.7	106.4	119.5	137.6	90.2	103.2	121.4
	7.5	98.0	111.0	129.2	97.2	110.2	128.4	70.2	83.2	140.4
	8.	93.8	106.8	125.0	82.2	95.2	113.4	44.4	57.4	75.6
	8.5	83.8	96.8	115.0	61.4	74.5	92.6	12.9	25.9	44.1
9.	68.0	81.0	99.2	34.9	47.9	66.1	-	-	6.8	
9.5	46.4	59.4	77.6	2.5	15.6	33.7	-	-	-	
10.	19.0	32.1	50.2	-	-	-	-	-	-	
250	4.	-	-	10.5	69.3	82.3	100.5	133.2	146.2	164.4
	4.5	19.2	32.2	50.4	94.7	107.7	125.9	144.1	157.1	175.3
	5.	53.3	66.3	84.5	114.4	127.4	145.6	149.2	162.2	180.4
	5.5	81.7	94.7	112.9	128.2	141.2	159.4	148.6	161.6	179.8
	6.	104.2	117.3	135.4	136.3	149.3	167.5	142.1	155.2	173.3
	6.5	121.1	134.1	152.3	138.6	151.6	169.8	130.6	143.0	161.2
	7.	132.1	145.1	163.3	135.2	148.2	166.4	112.0	125.0	143.2
	7.5	137.4	150.4	168.6	125.9	138.9	157.1	88.3	101.3	119.5
	8.	136.9	149.9	168.1	110.9	123.9	142.1	58.8	71.8	90.0
	8.5	130.6	143.6	161.8	90.2	103.2	121.4	23.5	36.5	54.7
9.	118.5	131.6	149.7	63.6	76.6	94.8	-	-	13.3	
9.5	100.7	113.7	131.9	31.3	44.3	62.5	-	-	-	
10.	77.1	90.2	108.3	-	6.2	24.4	-	-	-	
300	4.	-	5.4	23.6	98.0	111.0	129.2	177.5	190.5	208.7
	4.5	36.0	49.0	67.2	123.4	136.5	154.6	184.7	197.7	215.9
	5.	73.9	86.9	105.1	143.1	156.1	174.3	186.0	199.1	217.2
	5.5	106.0	119.0	137.2	156.9	170.0	188.1	181.6	194.7	212.8
	6.	132.3	145.4	163.5	165.0	178.0	196.2	171.5	184.5	202.7
	6.5	152.9	165.9	184.1	167.3	180.4	198.5	155.5	168.6	186.7
	7.	167.7	180.7	198.9	163.9	176.9	195.1	133.8	146.8	165.0
	7.5	176.7	189.7	207.9	154.6	167.7	185.8	106.3	119.4	137.5
	8.	180.0	193.0	211.2	139.6	152.7	170.8	73.1	86.1	104.3
	8.5	177.4	190.5	208.6	118.9	131.9	150.1	34.1	47.1	65.3
9.	169.1	182.2	200.3	92.3	105.3	123.5	-	2.3	20.5	
9.5	155.1	168.1	186.3	60.0	73.0	91.2	-	-	-	
10.	135.2	148.2	166.4	21.9	34.9	53.1	-	-	-	

TABLE 11. ESTIMATED INDIRECT TENSILE STRENGTHS FOR ASPHALT-TREATED GRAVEL MIXTURES

Asphalt Cement Type	Gradation	Asphalt Content, %	Compaction Temperature, °F	Fine			Medium			Coarse		
				AC-5	AC-10	AC-20	AC-5	AC-10	AC-20	AC-5	AC-10	AC-20
200	4.	9.	22.1	40.2	40.6	53.6	71.8	46.0	59.0	77.2		
	4.5	38.0	51.1	69.2	66.0	79.0	97.2	67.8	80.8	99.0		
	5.	61.3	74.3	92.5	85.7	98.7	116.9	83.8	96.8	115.0		
	5.5	78.7	91.8	109.9	99.5	112.5	130.7	94.1	107.1	125.3		
	6.	90.4	103.5	121.6	107.6	120.6	138.8	98.5	111.5	129.7		
	6.5	96.4	109.4	127.6	109.9	122.9	154.1	97.2	110.3	128.4		
	7.	96.5	109.5	127.7	106.4	119.5	137.6	90.2	103.2	121.4		
	7.5	90.9	103.9	122.1	97.2	110.2	128.4	77.3	90.3	108.5		
	8.	79.5	92.5	110.7	82.2	95.2	113.4	58.7	71.7	89.9		
	8.5	62.3	75.3	93.5	61.4	74.5	92.6	34.3	47.4	65.5		
	9.	39.4	52.4	70.6	34.9	47.9	66.1	4.2	17.2	35.4		
9.5	10.7	23.7	41.9	2.6	15.6	56.8	-	-	-			
10.	-	-	7.4	-	-	-	-	-	-			
250	4.	22.1	35.1	53.3	69.3	82.3	100.5	90.3	103.3	121.5		
	4.5	54.9	67.9	86.1	94.7	107.7	125.9	108.4	121.4	139.6		
	5.	81.9	94.9	113.1	114.4	127.4	145.6	120.6	133.6	151.8		
	5.5	103.1	116.1	134.3	128.2	141.2	159.4	127.1	140.1	158.3		
	6.	118.5	131.6	149.7	136.3	149.3	167.5	127.9	140.9	159.1		
	6.5	128.2	141.2	159.4	138.6	151.6	169.8	122.8	135.8	154.0		
	7.	132.1	145.1	163.3	135.2	148.2	166.4	112.0	125.0	143.2		
	7.5	130.2	143.2	161.4	125.9	138.9	157.1	95.4	108.4	126.6		
	8.	122.6	135.6	153.8	110.9	123.9	142.1	73.0	86.1	104.2		
	8.5	109.2	122.2	140.4	90.2	103.2	121.4	44.9	57.9	76.1		
	9.	90.0	103.0	134.2	63.6	76.6	94.8	11.0	24.0	42.2		
9.5	65.0	78.0	96.2	31.3	44.3	62.5	-	-	2.5			
10.	34.3	47.3	65.5	-	6.2	24.4	-	-	-			
300	4.	35.2	48.2	66.4	98.0	111.1	129.2	134.6	147.7	165.8		
	4.5	71.7	84.8	102.9	123.4	136.5	154.6	148.9	162.0	180.1		
	5.	102.5	115.5	133.7	143.1	156.1	174.3	157.5	170.5	188.7		
	5.5	127.4	140.5	158.6	156.9	170.0	188.1	160.2	173.2	191.4		
	6.	146.6	159.7	177.8	165.0	178.0	196.2	157.2	170.2	188.4		
	6.5	160.1	173.1	191.3	167.3	180.4	198.5	148.4	161.4	179.6		
	7.	167.7	180.7	198.9	163.9	176.9	195.1	133.8	146.8	165.0		
	7.5	169.6	182.6	200.8	154.6	167.7	185.8	113.5	126.5	144.7		
	8.	165.7	178.7	196.9	139.6	152.7	170.8	87.4	100.4	118.6		
	8.5	156.0	169.0	187.2	118.9	131.9	150.1	55.5	68.5	86.7		
	9.	140.6	153.6	171.8	92.3	105.3	123.5	17.8	30.9	49.0		
9.5	119.4	132.4	150.6	60.0	73.0	91.2	-	-	5.6			
10.	92.4	105.4	123.6	21.9	34.9	53.1	-	-	-			

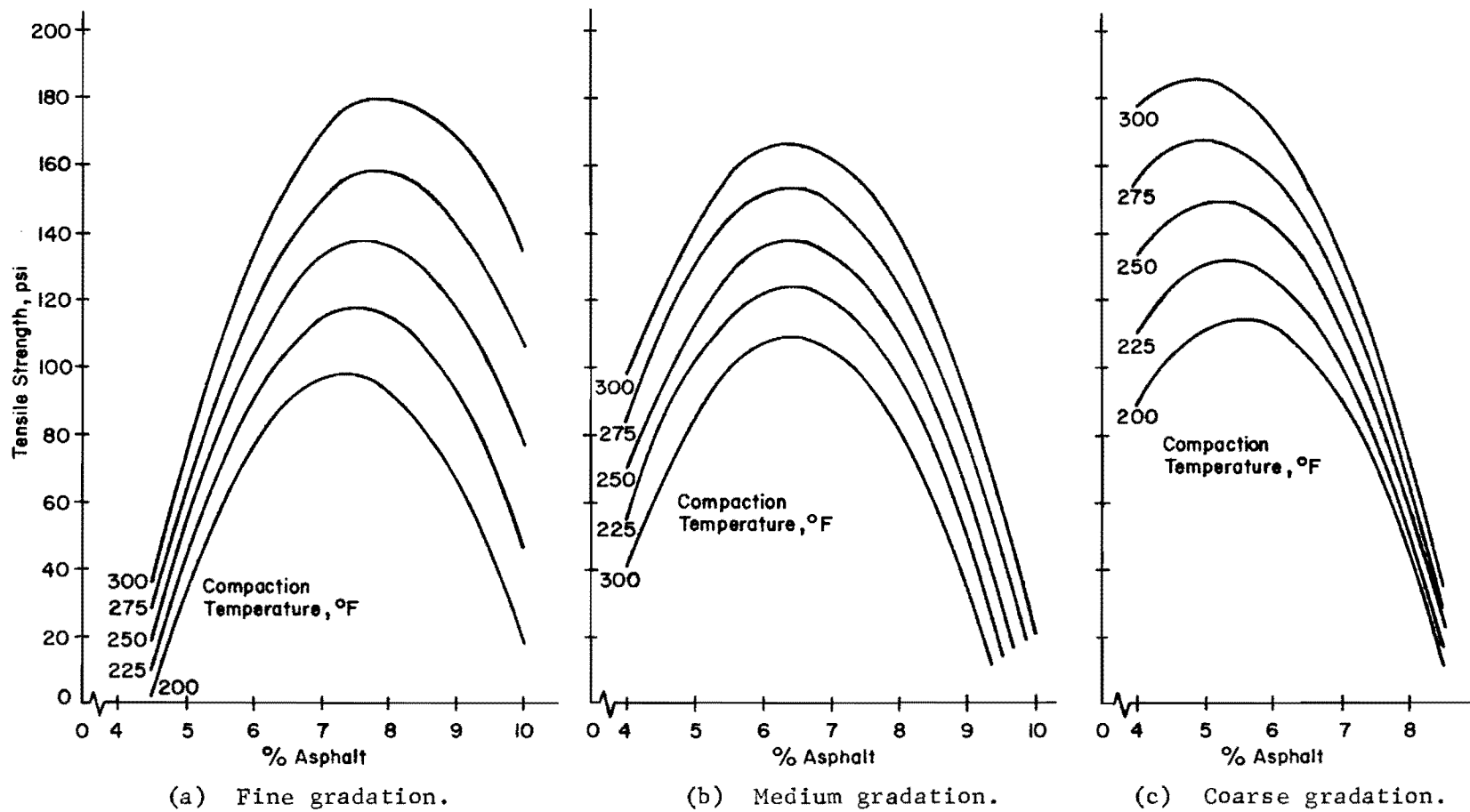

Correction for asphalt cement type: AC-10: estimated value + 13.0 psi  
 AC-20: estimated value + 31.2 psi

Fig 8. Estimated tensile strength values for crushed limestone, AC-5.

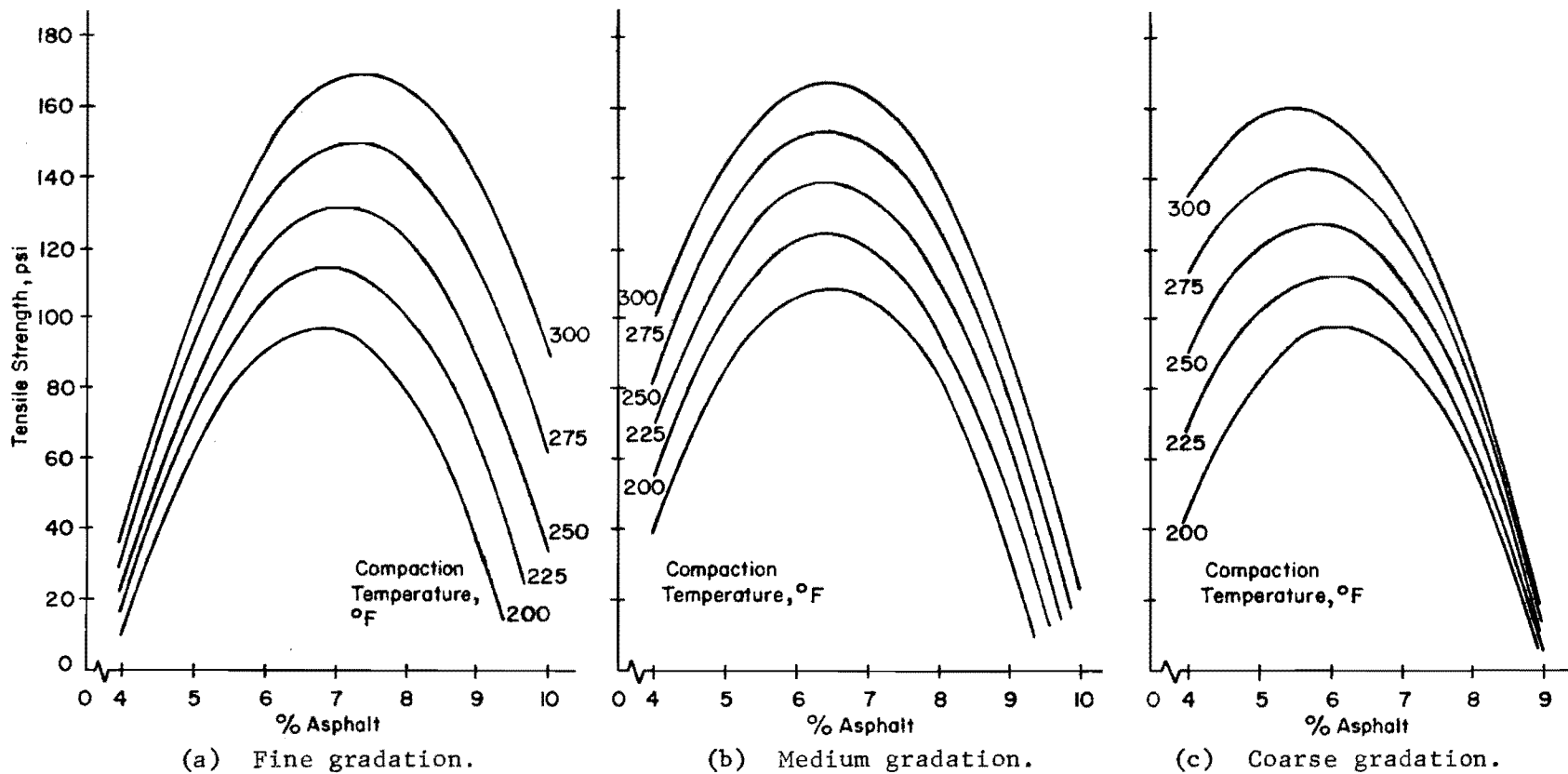

Correction for asphalt cement type: AC-10: estimated value + 13.0 psi  
 AC-20: estimated value + 31.2 psi

Fig 9. Estimated tensile strength values for Seguin gravel, AC-5.



so improved that more of the fine particles can be bound together by asphalt films.

For the coarse graded mixtures the asphalt may be distributed better even at the lower compaction temperatures; therefore it is hypothesized that approximately the same amount of asphalt was required at all compaction temperatures to coat the finer particles. For the coarse graded mixtures, the optimum asphalt content decreases with increased compaction temperature due to the increased fluidity, i.e., the higher compaction temperatures allowed the aggregate particles to be adequately coated and connected with a smaller quantity of asphalt.

#### Total Tensile Strain at Failure (75° F)

Estimations of the total tensile strain based on the regression equations are included in Table 12 while a plot graphically illustrating the estimations is presented in Fig 10. From this figure it can be seen that asphalt content had no effect on the total tensile strain of a mixture containing crushed limestone aggregate. On the other hand, for gravel-asphalt mixtures, the total tensile strain increased with increasing amounts of asphalt. For both aggregate types the compaction temperature had a noticeable effect on total tensile strain with increased compaction temperature producing a decrease in the tensile strain at failure. This decrease in strain is attributed to the fact that the increased fluidity of the asphalt during compaction at the higher temperatures resulted in improved distribution of the asphalt with thinner films connecting aggregate particles. Since deformation occurs primarily in the asphalt, these thinner films result in smaller strains.

The difference in the behavior of mixtures containing the two aggregate types is also attributed to the thickness of the asphalt films connecting the aggregate particles. The crushed limestone was highly porous and readily absorbed asphalt; thus it can be hypothesized that the limestone aggregate tended to absorb readily the available asphalt and produced asphalt films of essentially the same thickness. Thus it would be expected that the failure strain would be essentially constant for all the asphalt-crushed limestone mixtures. The gravel on the other hand is relatively nonporous and does not tend to absorb the available asphalt. Therefore, as the amount of asphalt in the gravel mixture increased, the thickness of the asphalt films connecting the aggregate particles increased. The thicker asphalt films then allowed larger deformations to occur, resulting in larger strains.

TABLE 12. ESTIMATED TOTAL TENSILE STRAIN, MICROUNITS

Aggregate Type Compaction Temperature, °F Asphalt Content, %	Crushed Limestone			Seguin Gravel		
	200	250	300	200	250	300
	4.0	1435	1275	1120	1245	1090
4.5	1435	1275	1120	1310	1150	995
5.0	1435	1275	1120	1370	1215	1060
5.5	1435	1275	1120	1435	1280	1120
6.0	1435	1275	1120	1500	1340	1185
6.5	1435	1275	1120	1565	1405	1250
7.0	1435	1275	1120	1625	1470	1310
7.5	1435	1275	1120	1690	1535	1375
8.0	1435	1275	1120	1755	1595	1440
8.5	1435	1275	1120	1820	1660	1505
9.0	1435	1275	1120	1880	1725	1565
9.5	1435	1275	1120	1945	1785	1630
10.0	1435	1275	1120	2010	1850	1695

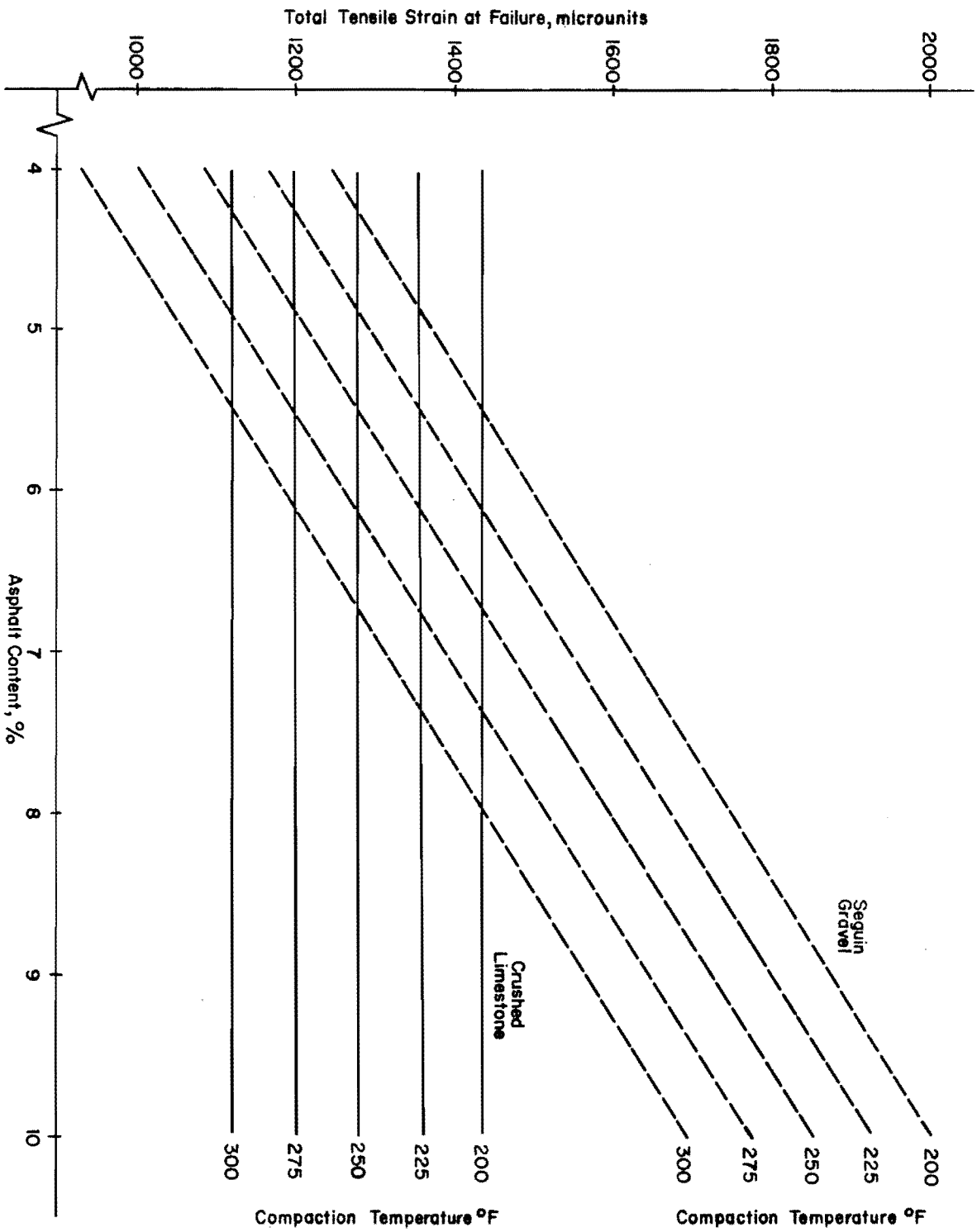

Fig 10. Estimated values for total tensile strain at failure.

### Modulus of Elasticity (75° F)

A review of the equation shows that only five of the seven variables were practically significant. These variables were aggregate type (Factor A), aggregate gradation (Factor B), asphalt cement type (Factor C), asphalt content (Factor D), and compaction temperature (Factor G). A number of moduli of elasticity for a variety of combinations of the five factors were estimated utilizing the equation and are included in Tables 13 and 14. In addition, plots indicating the relationship between asphalt content and compaction temperature for the three gradations and for each aggregate type are presented in Figs 11 and 12 for an AC-5 asphalt cement. These relationships will change linearly with change in asphalt cement type, since the effect of asphalt cement type was linear. Therefore, estimations of modulus of elasticity for mixes with AC-10 or AC-20 can be obtained by adding  $0.330 \times 10^5$  and  $0.790 \times 10^5$  respectively to the value obtained for an AC-5.

The relationships between asphalt content and compaction temperature for the different gradations of crushed limestone and gravel are similar to those for tensile strength. In all figures the effect of compaction temperature is evident. In addition, optimum asphalt contents are evident and shift slightly with increased compaction temperature for the fine and coarse graded mixtures. The optimum asphalt content for fine-graded increased with increased compaction temperature while the optimum for coarse graded mixtures decreased with higher compaction temperatures. In addition it may be noted that specimens containing coarser graded aggregate exhibited larger modulus values.

Since there were similarities in the trends observed for modulus of elasticity (Figs 11 and 12) and tensile strength (Figs 9 and 10), the explanation of the relationship between tensile strength and the five significant (or important) variables can also be used to explain the relationship between modulus of elasticity and the same five variables.

There were, however, two distinct differences in the results for modulus of elasticity and tensile strength. First of all, although there were no differences in tensile strengths between asphalt-treated mixtures containing crushed limestone or gravel, there were differences in moduli of elasticity for the two different aggregate mixtures. Secondly, coarse graded mixtures containing gravel generally exhibited higher moduli of elasticity but lower tensile strengths. Both are attributable to the difference in the failure strain behavior of mixtures containing the two aggregates.

TABLE 13. ESTIMATED MODULUS OF ELASTICITY VALUES FOR ASPHALT-TREATED LIMESTONE MIXTURES

Note: All values are in psi and must be multiplied by 10<sup>5</sup>

Asphalt Content, %	Gradation	Asphalt-Treated Limestone Mixtures								
		Fine			Medium			Coarse		
		AC-5	AC-10	AC-20	AC-5	AC-10	AC-20	AC-5	AC-10	AC-20
200	4.	-	-	0.322	1.401	1.732	2.194	2.485	2.816	3.278
	4.5	.300	.630	1.093	1.926	2.256	2.719	2.763	3.094	3.556
	5.	.942	1.272	1.735	2.322	2.652	3.115	2.913	3.243	3.706
	5.5	1.456	1.786	2.249	2.589	2.920	3.382	2.934	3.264	3.727
	6.	1.841	2.172	2.634	2.728	3.059	3.521	2.827	3.157	3.620
	6.5	2.098	2.428	2.891	2.739	3.069	3.532	2.591	2.921	3.384
	7.	2.226	2.557	3.019	2.621	2.951	3.414	2.226	2.557	3.019
	7.5	2.226	2.557	3.019	2.374	2.704	3.167	1.734	2.064	2.527
	8.	2.098	2.428	2.891	1.999	2.329	2.792	1.112	1.442	1.905
	8.5	1.840	2.171	2.633	1.496	1.826	2.289	0.362	.693	1.155
9.	1.455	1.785	2.248	.864	1.194	1.657	-	-	.277	
9.5	.941	1.271	1.734	.103	.433	0.896	-	-	-	
10.	.298	0.628	1.091	-	-	-	-	-	-	
250	4.	-	-	0.316	2.163	2.493	2.956	4.014	4.344	4.807
	4.5	.422	.752	1.215	2.687	3.018	3.480	4.164	4.494	4.957
	5.	1.192	1.522	1.985	3.083	3.414	3.876	4.186	4.516	4.979
	5.5	1.834	2.164	2.627	3.351	3.681	4.144	4.079	4.409	4.872
	6.	2.347	2.677	3.140	3.490	3.820	4.283	3.844	4.174	4.637
	6.5	2.732	3.062	3.525	3.500	3.830	4.293	3.480	3.810	4.273
	7.	2.988	3.318	3.781	3.382	3.712	4.175	2.988	3.318	3.781
	7.5	3.116	3.446	3.909	3.136	3.466	3.929	2.367	2.697	3.160
	8.	3.115	3.445	3.908	2.761	3.091	3.554	1.618	1.948	2.411
	8.5	2.985	3.316	3.778	2.257	2.587	3.050	0.740	1.070	1.533
9.	2.728	3.058	3.521	1.625	1.955	2.418	-	.064	.527	
9.5	2.341	2.672	3.134	.865	1.195	1.658	-	-	-	
10.	1.826	2.157	2.619	-	.306	.669	-	-	-	
300	4.	-	-	0.311	2.924	3.255	3.717	5.542	5.873	6.335
	4.5	.544	.875	1.337	3.449	3.779	4.242	5.565	5.895	6.358
	5.	1.442	1.773	2.235	3.845	4.175	4.638	5.459	5.789	6.252
	5.5	2.212	2.542	3.005	4.112	4.443	4.905	5.224	5.554	6.017
	6.	2.853	3.183	3.646	4.251	4.581	5.044	4.861	5.191	5.654
	6.5	3.365	3.696	4.158	4.262	4.592	5.055	4.369	4.700	5.162
	7.	3.749	4.080	4.542	4.144	4.474	4.937	3.749	4.080	4.542
	7.5	4.005	4.335	4.798	3.897	4.227	4.690	3.001	3.331	3.794
	8.	4.132	4.462	4.925	3.522	3.852	4.315	2.124	2.454	2.917
	8.5	4.130	4.461	4.923	3.019	3.349	3.812	1.118	1.448	1.911
9.	4.000	4.331	4.793	2.387	2.717	3.180	-	.314	.777	
9.5	3.742	4.072	4.535	1.626	1.956	2.419	-	-	-	
10.	3.355	3.685	4.148	0.737	1.067	1.530	-	-	-	

TABLE 14. ESTIMATED MODULUS OF ELASTICITY VALUES FOR ASPHALT-TREATED GRAVEL MIXTURES

Note: All values are in psi and must be multiplied by  $10^5$

Asphalt-Cement Type	Asphalt Content, %	Compaction, %	Temperature, °F	Gradation			Fine			Medium			Coarse		
				Gradation			Fine			Medium			Coarse		
				AC-5	AC-10	AC-20	AC-5	AC-10	AC-20	AC-5	AC-10	AC-20	AC-5	AC-10	AC-20
200	4.	-	.263	.725	.906	1.236	1.699	1.091	1.421	1.884					
	4.5	.554	.884	1.347	1.430	1.761	2.223	1.519	1.849	2.312					
	5.	1.046	1.376	1.839	1.826	2.157	2.619	1.818	2.149	2.611					
	5.5	1.410	1.740	2.203	2.094	2.424	2.887	1.989	2.319	2.782					
	6.	1.645	1.976	2.438	2.233	2.563	3.026	2.032	2.362	2.825					
	6.5	1.752	2.083	2.545	2.243	2.574	3.036	1.946	2.276	2.739					
	7.	1.731	2.061	2.524	2.125	2.456	2.918	1.731	2.061	2.524					
	7.5	1.581	1.911	2.374	1.879	2.209	2.672	1.388	1.718	2.181					
	8.	1.302	1.633	2.095	1.504	1.834	2.297	.916	1.247	1.709					
	8.5	.896	1.226	1.689	1.000	1.330	1.793	.316	.647	1.109					
	9.	.360	.690	1.153	.368	.698	1.161	-	-	0.381					
9.5	-	.026	0.489	-	-	0.401	-	-	-						
10.	-	-	-	-	-	-	-	-	-						
250	4.	-	.257	.720	1.667	1.998	2.460	2.619	2.950	3.412					
	4.5	.676	1.006	1.469	2.192	2.522	2.985	2.919	3.250	3.712					
	5.	1.296	1.626	2.089	2.588	2.918	3.381	3.091	3.421	3.884					
	5.5	1.788	2.118	2.581	2.855	3.186	3.648	3.134	3.464	3.927					
	6.	2.151	2.481	2.944	2.994	3.325	3.787	3.049	3.379	3.842					
	6.5	2.386	2.716	3.179	3.005	3.335	3.798	2.835	3.165	3.628					
	7.	2.492	2.823	3.285	2.887	3.217	3.680	2.492	2.823	3.285					
	7.5	2.470	2.801	3.263	2.640	2.970	3.433	2.022	2.352	2.815					
	8.	2.320	2.650	3.113	2.265	2.595	3.058	1.422	1.752	2.215					
	8.5	2.040	2.371	2.833	1.762	2.092	2.555	.694	1.024	1.487					
	9.	1.633	1.963	2.426	1.130	1.460	1.923	-	.168	0.631					
9.5	1.097	1.427	1.890	.369	.699	1.162	-	-	-						
10.	0.432	.762	1.225	-	-	0.273	-	-	-						
300	4.	-	.252	.714	2.429	2.759	3.222	4.148	4.478	4.941					
	4.5	.798	1.128	1.591	2.953	3.284	3.746	4.320	4.650	5.113					
	5.	1.546	1.876	2.339	3.349	3.680	4.142	4.364	4.694	5.157					
	5.5	2.166	2.496	2.959	3.617	3.947	4.410	4.279	4.609	5.072					
	6.	2.657	2.987	3.450	3.756	4.086	4.549	4.066	4.396	4.859					
	6.5	3.020	3.350	3.813	3.766	4.096	4.559	3.724	4.054	4.517					
	7.	3.254	3.584	4.047	3.648	3.978	4.441	3.254	3.584	4.047					
	7.5	3.360	3.690	4.153	3.402	3.732	4.195	2.655	2.985	3.448					
	8.	3.337	3.667	4.130	3.027	3.357	3.820	1.928	2.258	2.721					
	8.5	3.185	3.516	3.978	2.523	2.853	3.316	1.072	1.402	1.865					
	9.	2.906	3.236	3.699	1.891	2.221	2.684	.088	.418	0.881					
9.5	2.497	2.828	3.290	1.131	1.461	1.924	-	-	-						
10.	1.961	2.291	2.754	.242	.572	1.035	-	-	-						

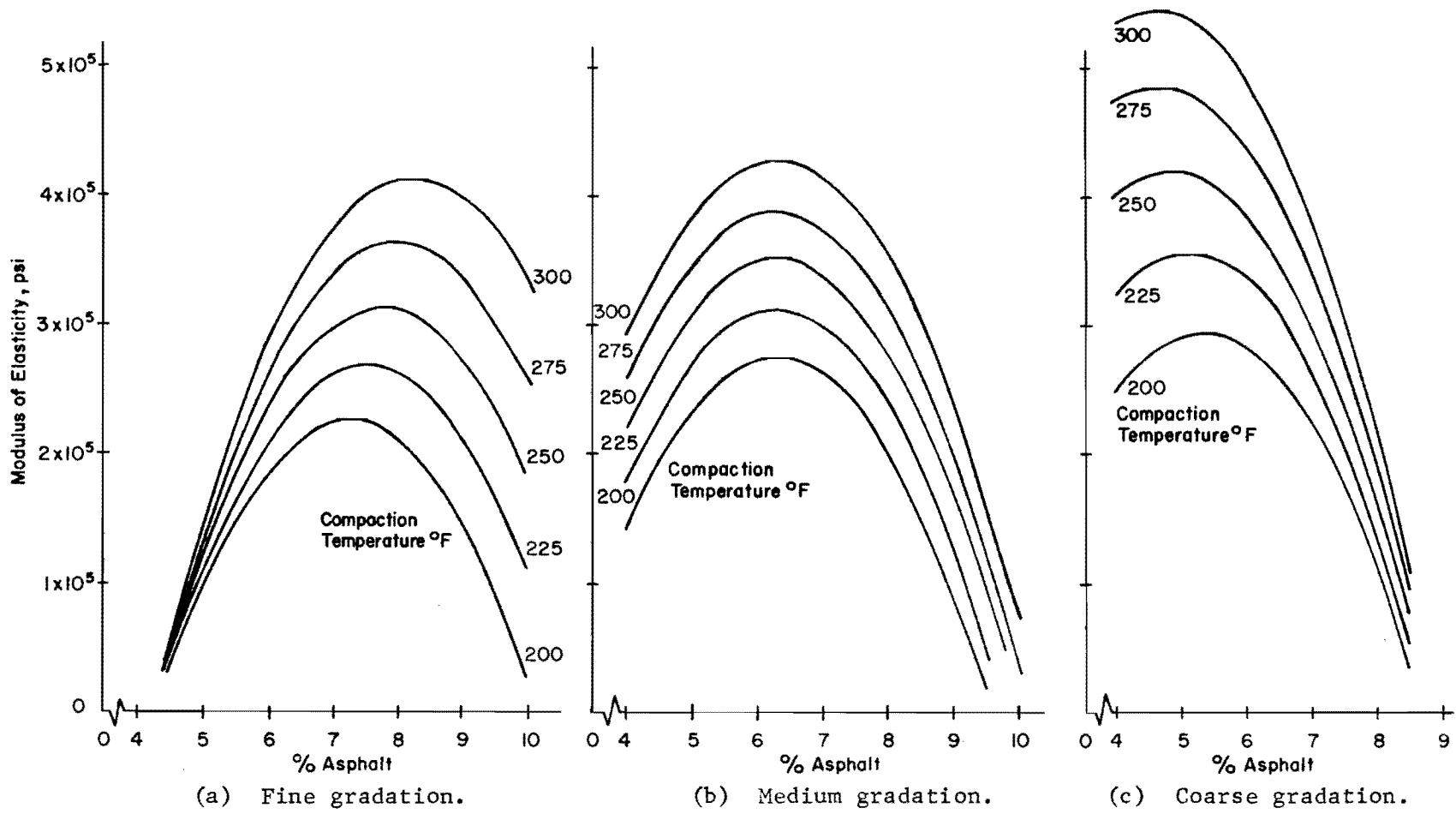

Correction for asphalt cement type: AC-10: estimated value +  $0.330 \times 10^5$  psi  
 AC-20: estimated value +  $0.793 \times 10^5$  psi

Fig 11. Estimated modulus of elasticity values for crushed limestone, AC-5.

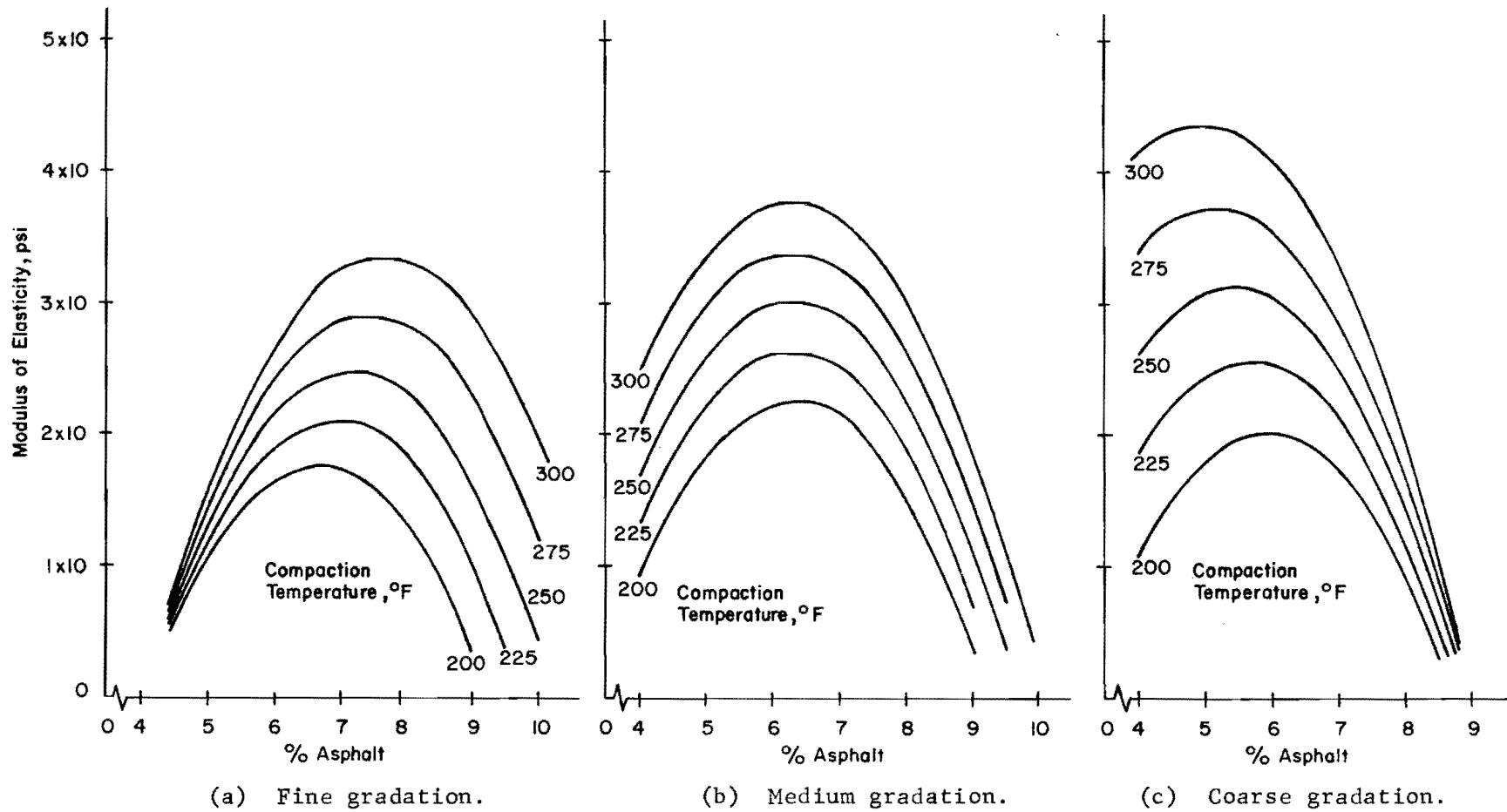

Correction for asphalt cement type: AC-10: estimated value +  $0.330 \times 10^5$  psi  
 AC-20: estimated value +  $0.793 \times 10^5$  psi

Fig 12. Estimated modulus of elasticity values for gravel, AC-5.



Since modulus of elasticity is defined as the ratio of stress to strain, the modulus of elasticity from the indirect tensile test can also be related as the ratio of tensile strength to tensile strain at failure. Using this analogy the modulus of elasticity of crushed limestone-asphalt mixtures should be related linearly to tensile strength because these mixtures exhibited constant tensile failure strains (Fig 10). On the other hand, although the gravel-asphalt mixtures exhibited higher tensile strengths than the crushed limestone-asphalt mixtures, lower moduli of elasticity were produced because of greater tensile strains for the gravel-asphalt mixtures.

The second difference can be explained in a similar manner. The optimum asphalt content for the coarse graded gravel-asphalt mixture was smaller than for the medium and fine graded gravel-asphalt mixtures; therefore, the tensile strains were lower and offset the lower tensile strengths producing higher moduli of elasticity.

#### Poisson's Ratio

The regression equation includes only the four factors of aggregate type (Factor A), aggregate gradation (Factor B), asphalt content (Factor D), and compaction temperature (Factor G). Values of Poisson's ratios for a variety of combinations of these four variables were estimated utilizing the regression equation and are summarized in Table 15. The relationships between these estimated values and the factors of asphalt content and compaction temperature for mixtures containing finely graded crushed limestone and rounded gravel are shown in Fig 13. The effect produced by a change in gradation for either aggregates can be obtained by the correction factors shown on the figures.

For mixtures containing crushed limestone aggregate, the effect of asphalt content on Poisson's ratio is slight; whereas, the effect of compaction temperature is much larger. In fact, the magnitude of Poisson's ratio decreased as the compaction temperature increased. From the correction factor it is seen that Poisson's ratio decreased as the gradation became coarser.

On the other hand, for mixtures containing Seguin gravel aggregate, the amount of asphalt in the mix had more of an effect on Poisson's ratio than compaction temperature. The Poisson's ratio increased with increased asphalt content, decreasing the compaction temperature, and with coarser mixes.

TABLE 15. ESTIMATED VALUES OF POISSON'S RATIO

Aggregate Type		Crushed Limestone						Seguin Gravel		
		Crushed Limestone			Seguin Gravel			Seguin Gravel		
		Fine	Medium	Coarse	Fine	Medium	Coarse	Fine	Medium	Coarse
250	4.0	.310	.281	.251	.083	.113	.142			
	4.5	.308	.279	.249	.109	.139	.168			
	5.0	.307	.277	.248	.136	.165	.195			
	5.5	.305	.275	.246	.162	.191	.221			
	6.0	.303	.274	.244	.188	.218	.247			
	6.5	.302	.272	.243	.214	.244	.274			
	7.0	.300	.270	.241	.241	.270	.300			
	7.5	.298	.269	.239	.267	.297	.326			
	8.0	.296	.267	.237	.293	.323	.352			
	8.5	.295	.265	.236	.320	.349	.379			
	9.0	.293	.263	.234	.346	.375	.405			
	9.5	.291	.262	.232	.372	.402	.431			
10.0	.289	.260	.230	.398	.428	.458				
300	4.0	.247	.218	.188	.020	.050	.079			
	4.5	.246	.216	.187	.046	.076	.106			
	5.0	.244	.214	.185	.073	.102	.132			
	5.5	.242	.213	.183	.099	.129	.158			
	6.0	.246	.211	.181	.125	.155	.184			
	6.5	.239	.209	.180	.152	.181	.211			
	7.0	.237	.207	.178	.178	.207	.237			
	7.5	.235	.206	.176	.204	.234	.263			
	8.0	.233	.204	.174	.230	.260	.290			
	8.5	.232	.202	.173	.257	.286	.316			
	9.0	.230	.260	.171	.283	.213	.342			
	9.5	.228	.199	.169	.309	.339	.368			
10.0	.227	.197	.168	.336	.365	.395				
350	4.0	.184	.155	.125	-	-	.016			
	4.5	.183	.153	.124	-	.013	.043			
	5.0	.181	.151	.122	.010	.039	.069			
	5.5	.179	.150	.120	.036	.066	.095			
	6.0	.178	.148	.118	.062	.092	.121			
	6.5	.176	.146	.118	.089	.118	.148			
	7.0	.174	.145	.115	.115	.145	.174			
	7.5	.172	.143	.113	.141	.171	.200			
	8.0	.171	.141	.112	.168	.197	.227			
	8.5	.169	.139	.110	.194	.223	.253			
	9.0	.167	.138	.108	.220	.250	.279			
	9.5	.165	.136	.106	.246	.276	.305			
10.0	.164	.134	.105	.273	.302	.332				

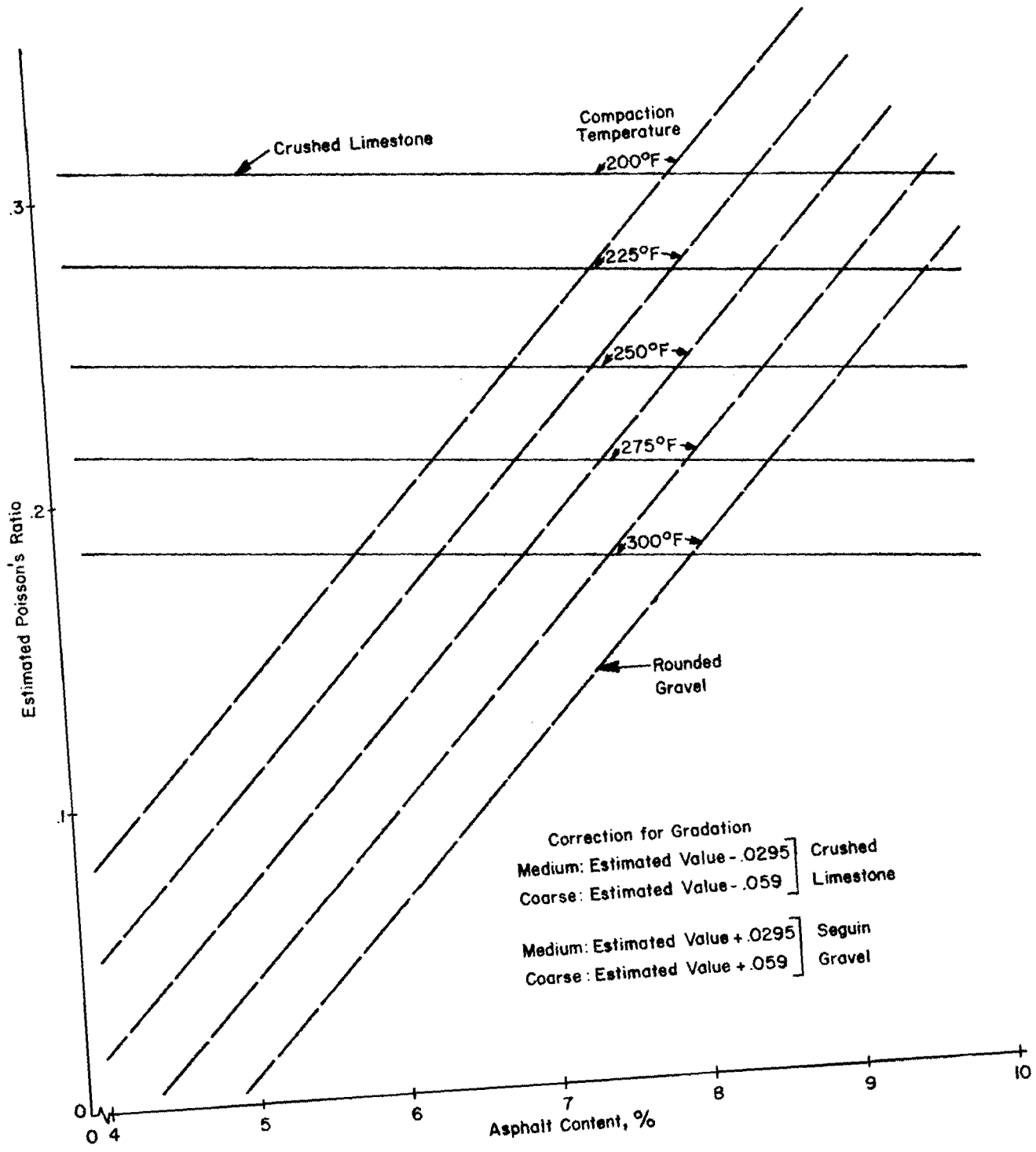

Fig 13. Estimated Poisson's ratio values: fine gradation.

Since Poisson's ratio is defined as the ratio of horizontal strain to vertical strain, it should correspond closely with tensile strain results obtained in this study. A comparison of Figs 10 and 13 establishes this fact; therefore, the explanation of the effects presented for total tensile strain are also applicable for discussion of the important factors affecting Poisson's ratio.

#### Elastic Tensile Strain at Failure

Estimates of the elastic tensile strain at failure are included in Table 16 and a variety of combinations of the three factors of aggregate type, asphalt content, and compaction temperature are shown in Fig 14 for an AC-5 asphalt cement. The correction factor for estimating elastic strains for asphalt cement types other than an AC-5 is indicated on the figures.

The elastic tensile strain at failure increased slightly for mixtures containing crushed limestone while it increased substantially for mixtures of gravel. For both aggregate types, the elastic tensile strain that a mixture can withstand decreased with an increase in the compaction temperature. The change of asphalt type from AC-5 to AC-10 or AC-20 for crushed limestone aggregate produced lower estimated elastic tensile strain, while the same change for a mixture containing the gravel produced higher tensile strain values.

#### Additional Mixture Properties

The density and air void content of a mixture are two other aspects concerned with the behavior of asphalt-treated materials which must also be considered. It can be reasoned that changes in tensile strength or modulus of elasticity are the result of nothing more than a change in density or air void content.

The density as well as air void content of an asphalt mix are of concern in design; however, both were difficult to control in this experiment since they were dependent upon the factors involved in the mixing and compaction procedures. Thus density and air void content were not independent variables but were considered as dependent or response variables similar to modulus of elasticity and tensile strength.

In general it is considered that density is related to material properties with higher densities corresponding to higher strengths or modulus of elasticity. Similarly since air void content is related to density, decreases in air voids

TABLE 16. ESTIMATED ELASTIC TENSILE STRAINS, MICROUNITS

Compaction Temperature, °F	Asphalt Content, %	Asphalt Cement Type	Crushed Limestone			Seguin Gravel		
			AC-5	AC-10	AC-20	AC-5	AC-10	AC-20
			Aggregate Type					
250	4.0		699	664	615	582	616	665
	4.5		724	689	640	634	668	717
	5.0		748	713	664	687	721	770
	5.5		770	737	689	739	773	822
	6.0		797	762	713	792	826	875
	6.5		821	786	737	844	878	927
	7.0		846	811	762	897	931	980
	7.5		870	835	786	949	983	1032
	8.0		895	860	811	1002	1036	1085
	8.5		919	884	835	1054	1089	1137
	9.0		944	909	860	1107	1141	1190
	9.5		968	933	884	1159	1194	1242
10.0		992	957	908	1212	1246	1295	
300	4.0		547	547	547	512	512	512
	4.5		571	571	571	565	565	565
	5.0		596	596	596	618	618	618
	5.5		620	620	620	670	670	670
	6.0		645	645	645	723	723	723
	6.5		669	669	669	775	775	775
	7.0		694	694	694	828	828	828
	7.5		718	718	718	880	880	880
	8.0		743	743	743	933	933	933
	8.5		767	767	767	985	985	985
	9.0		791	791	791	1038	1038	1038
	9.5		816	816	816	1090	1090	1090
10.0		840	840	840	1143	1143	1143	
350	4.0		395	429	478	443	408	359
	4.5		419	454	502	496	461	412
	5.0		444	478	527	548	513	464
	5.5		468	502	551	601	566	517
	6.0		493	527	576	654	619	570
	6.5		517	551	600	706	671	622
	7.0		541	576	624	759	724	675
	7.5		566	600	649	811	776	727
	8.0		590	625	673	864	829	780
	8.5		615	649	698	916	881	832
	9.0		639	673	722	969	934	885
	9.5		664	698	747	1021	986	937
10.0		688	722	771	1074	1039	990	

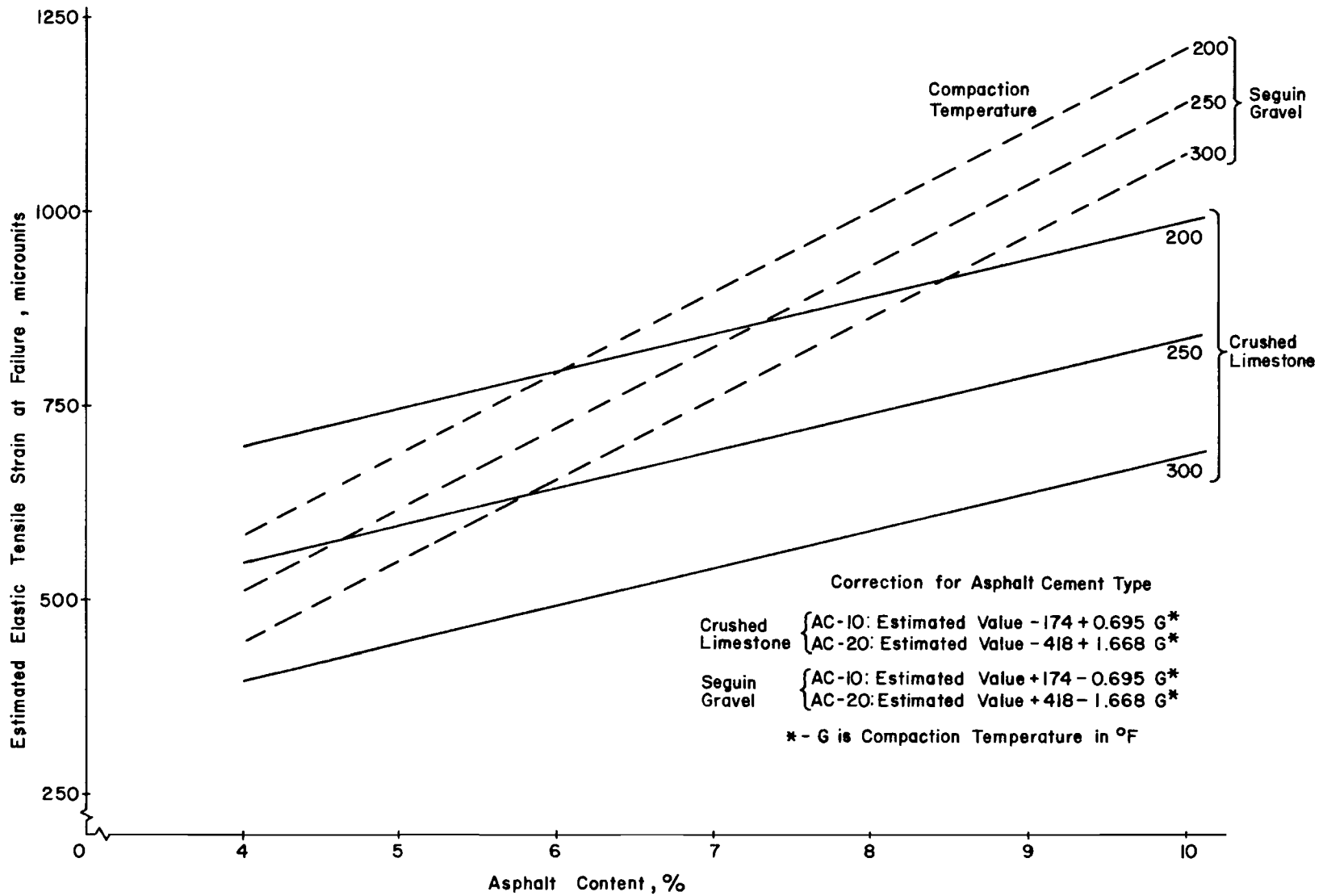

Fig 14. Estimated elastic tensile strain at failure, microunits.

should also correspond to higher strengths and modulus of elasticity. If this were true then there should be a good correlation between density and air voids and both modulus of elasticity and tensile strength.

Although in Figs 17 and 18 there appeared to be optimum air void contents for both tensile strength and modulus of elasticity, there is no previous evidence to indicate that such a phenomenon occurs. Therefore linear correlation analyses were conducted which indicated that there was no linear trend or correlation between (1) tensile strength and density (Fig 15), (2) modulus of elasticity and density (Fig 16), (3) tensile strength and air void content (Fig 17), and (4) modulus of elasticity and air void content (Fig 18). The linear regression relationship relating the two tensile properties to density and air void content are included in the figures along with the correlation coefficient  $R$  and the standard error of estimate  $\hat{S}_r$ . The slopes of the lines are very flat, indicating that the modulus of elasticity and strength were relatively independent of density and air void content.

These results indicate that an increase in density or decrease in air voids may or may not be indicative of an increase in the modulus of elasticity or tensile strength. On the other hand it has been shown that there are mixture variables such as aggregate type, gradation, asphalt cement type, asphalt content, and compaction temperature which can have a great influence on both the modulus of elasticity and tensile strength. Therefore changes in density or air voids alone cannot be used as a measure of expected changes in tensile properties of the mix but must be accompanied by careful consideration of the factors involved in the mix design.

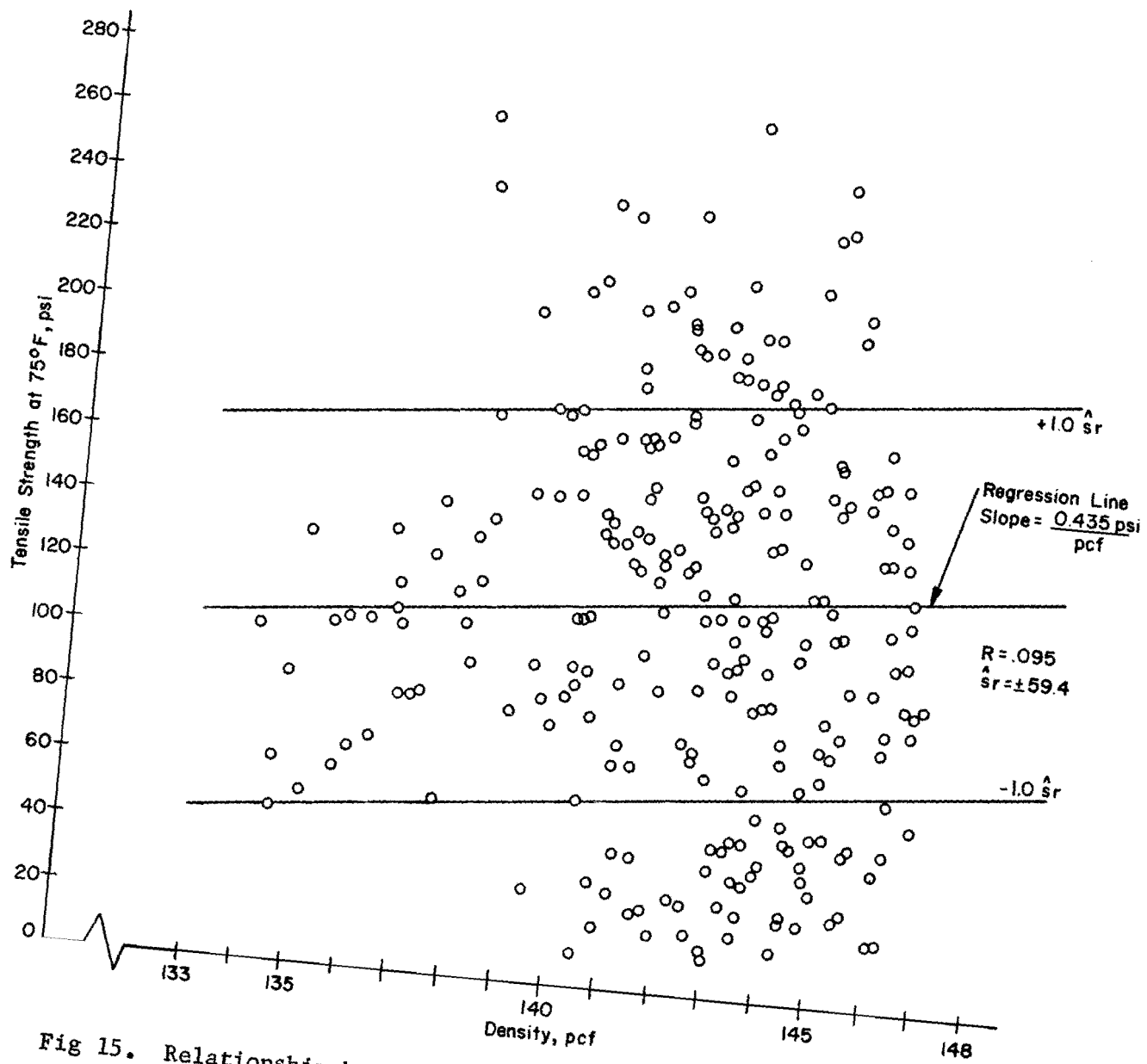

Fig 15. Relationship between tensile strength and bulk density (75° F).



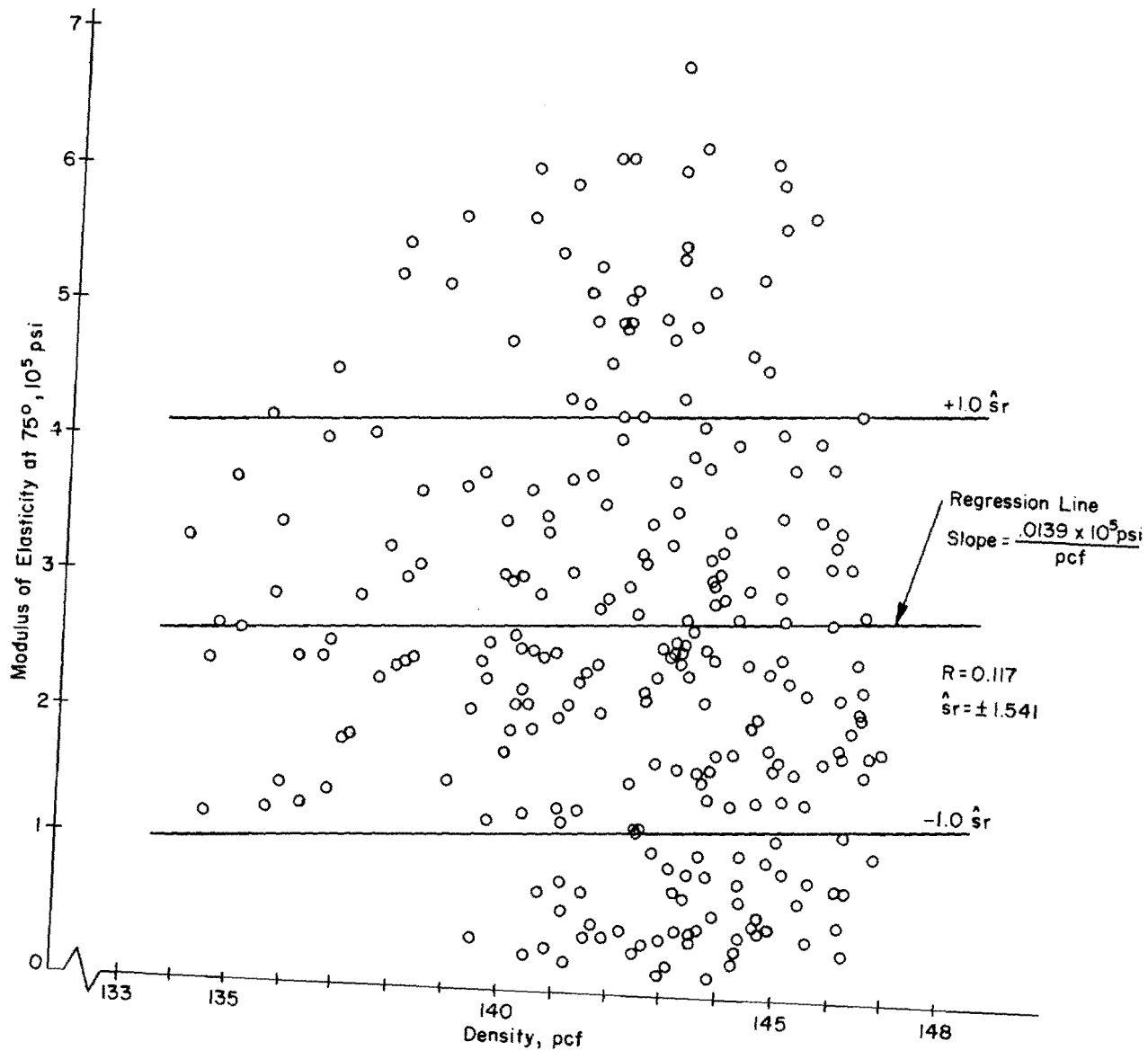

Fig 16. Relationship between modulus of elasticity and bulk density (75° F).

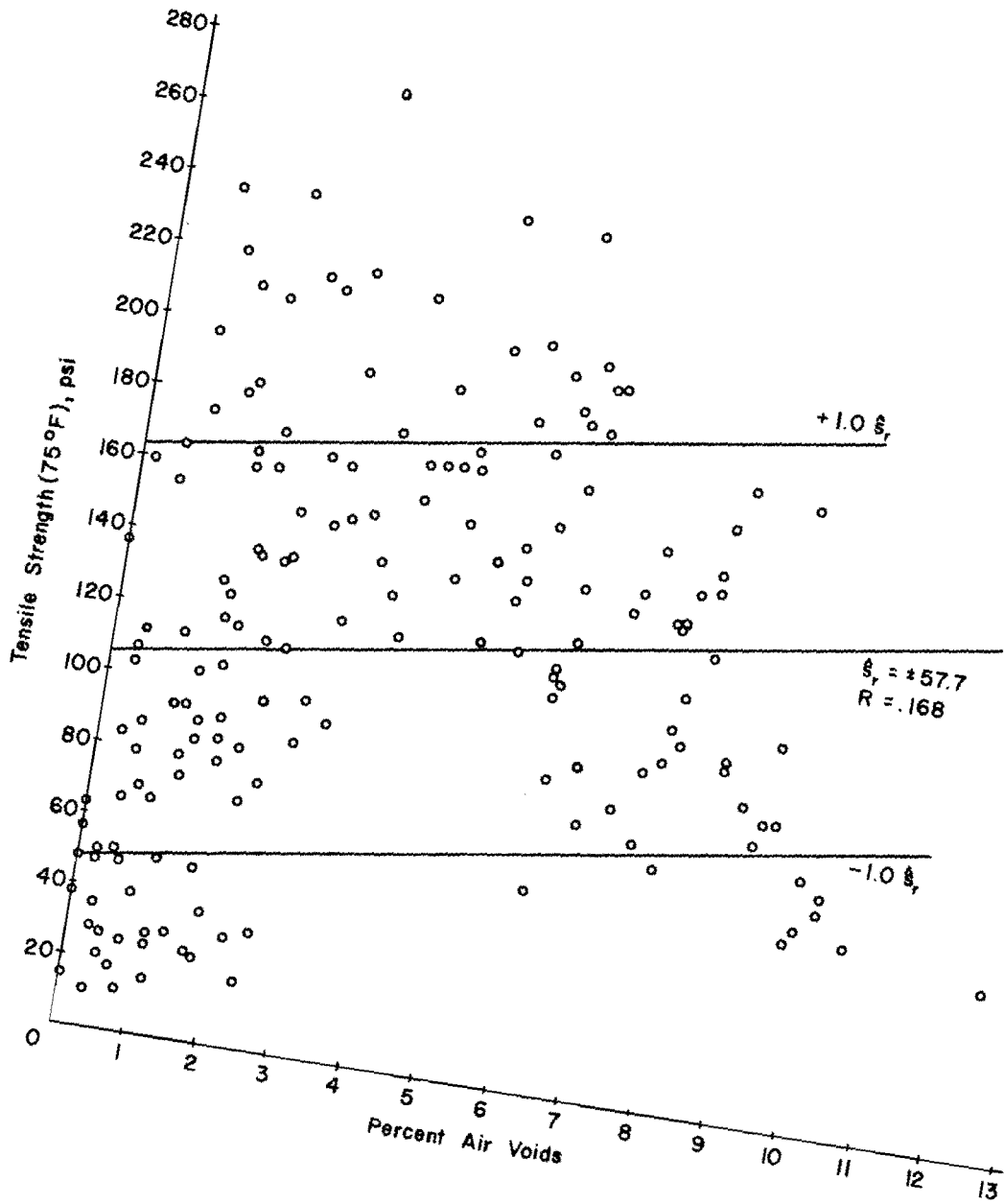

Fig 17. The relationship between tensile strength and air voids.

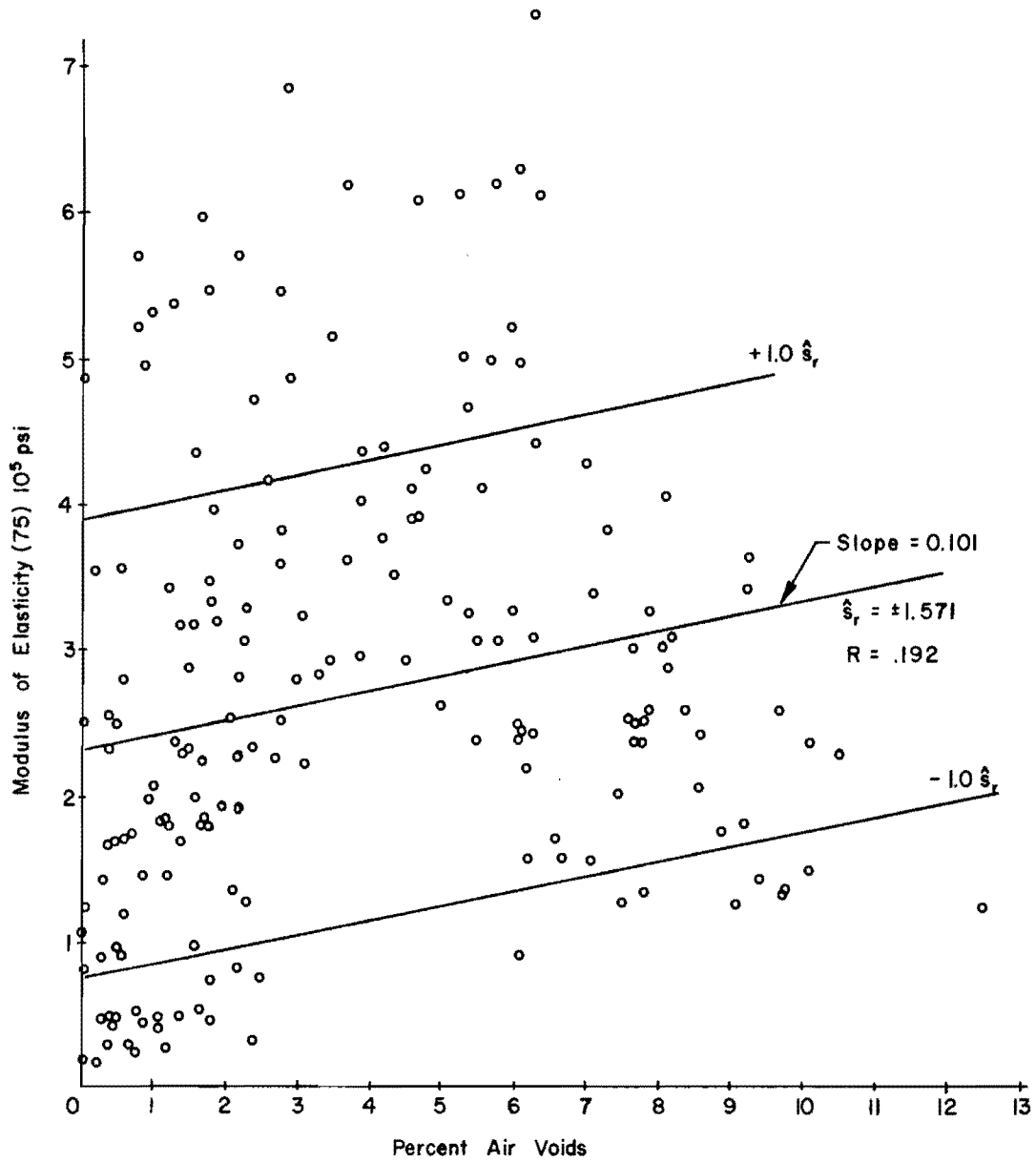

Fig 18. The relationship between modulus of elasticity and air voids (75° F).

#### CHAPTER 4. SUMMARY AND CONCLUSIONS

As in any controlled experimentation, the findings and conclusions resulting from this study are limited to the range of variables considered in the study. Attempts to extend the results or apply them outside of the factor space defined by the study should be made with caution. On the basis of the data and the analysis described, the following conclusions were made.

The phasing evaluation indicated that there was apparently no difference between the experimental error variance (duplicate error) and error variance in the three phases for the parameters modulus of elasticity, Poisson's ratio, tensile strength, and estimated elastic tensile strain at failure. On the other hand, the evaluation indicated a difference between the variances for the parameter total tensile strain at failure. All parameters however could be analyzed as if the experiment were a completely randomized experiment. The experimental error variances for the parameters were as follows:

- (1) modulus of elasticity:  $0.539 \times 10^{10}$  with 79 degrees of freedom,
- (2) Poisson's ratio: .0165 with  $df = 79$ ,
- (3) tensile strength: 459.02 with  $df = 79$ ,
- (4) total tensile strain at failure:  $0.164 \times 10^{-6}$  with  $df = 64$ , and
- (5) estimated elastic tensile strain at failure:  $3.030 \times 10^{-8}$  with 79 degrees of freedom.

The results of the analysis for the five material characterization constants indicated those factors which significantly affected these five properties. The analysis therefore indicated which factors should be considered important in determining the value of each of the material characterization constants. The important factors for each parameter are listed below.

<u>Material property (75° F)</u>	<u>Important factors</u>
Modulus of elasticity and tensile strength	Aggregate type Aggregate gradation Asphalt cement type Asphalt content Compaction temperature

<u>Material property (75° F)</u>	<u>Important factors</u>
Poisson's ratio	Aggregate type Aggregate gradation Asphalt content Compaction temperature
Total tensile strain at failure	Aggregate type Asphalt content Compaction temperature
Elastic tensile strain at failure	Aggregate type Asphalt cement type Asphalt content Compaction temperature

Regression analyses were conducted on those main factors and interactions which were considered to be of practical engineering significance to obtain prediction equations for modulus of elasticity, Poisson's ratio, tensile strength, total tensile strain at failure, and elastic tensile strain at failure. The equations for modulus of elasticity, tensile strength, and elastic tensile strain have been shown to be very reliable and can be used to predict the variations in these three responses with changes in aggregate type, gradation, asphalt cement type, asphalt content, and compaction temperature. On the other hand, the equation for Poisson's ratio and total tensile strain at failure are not as reliable as the others but nevertheless can be used to provide better estimates of the two properties than is presently available. In all cases, the decision as to whether to use these equations must be based on the error which can be tolerated. Nevertheless, it is felt that these equations are the best estimators currently available.

Equations (1) through (5) presented in Chapter 3 can then be used to estimate the tensile properties, i.e., modulus of elasticity, Poisson's ratio, tensile strength and strains at failure, of asphalt-stabilized materials for a variety of combinations of factors such as aggregate type, gradation, asphalt cement type, asphalt content, and compaction.

Estimates of all five material properties at 75° F for a variety of combinations of the independent variables are included in Tables 10 through 14. Visual representations of the interrelationships between the response variables, modulus of elasticity, Poisson's ratio, tensile strength, and tensile strains at failure and a number of the mix variables are presented in the report and indicate the dominant effect of compaction temperature on all five material properties.

Since optimum asphalt contents were detected for the modulus of elasticity and tensile strength it would appear that the indirect tensile test can be used to obtain optimum mix designs. The optimum asphalt content obtained, however, will depend upon the aggregate type, aggregate gradation, and compaction temperature. Although a set of design tests may be needed to complement the results, the tables presented can be used to provide preliminary estimates and narrow the range of investigation in the laboratory.

Since there was no correlation between either modulus of elasticity and density or tensile strength and density for the conditions of the test, changes in density alone cannot be used as a measure of expected changes in tensile properties of the mix but must be accompanied by careful consideration of the factors involved in the mix design.

The effect of compaction temperature could explain some of the differences observed in the past between laboratory and field results because most laboratory procedures involve preparation of materials at certain fixed compaction temperatures. If the mixtures are compacted in the field at temperatures much different than those used in laboratory tests, then certainly, as evidenced by the results of the study, the mixture cannot be expected to perform in the field as predicted in the laboratory. Closer control of compaction temperature in the field through specification requirements could produce mixture properties closer to those design mixtures established in the laboratory and could substantially increase uniformity of mixtures along the length of the highway.

Present laboratory test procedures should be extended to include the evaluation of effects of changes in compaction temperature.

#### REFERENCES

1. Hadley, William O., W. Ronald Hudson, and Thomas W. Kennedy, "A Comprehensive Structural Design for Stabilized Pavement Layers," Center for Highway Research, The University of Texas at Austin, research report in progress.
2. Hadley, William O., W. Ronald Hudson, and Thomas W. Kennedy, "An Evaluation of Factors Affecting the Tensile Properties of Asphalt-Treated Materials," Research Report No. 98-2, Center for Highway Research, The University of Texas at Austin, March 1969.
3. Hadley, William O., W. Ronald Hudson, and Thomas W. Kennedy, "A Method of Estimating Tensile Properties of Materials Tested in Indirect Tension," Research Report No. 98-7, Center for Highway Research, The University of Texas at Austin, July 1970.
4. Cochran, William G., and Gertrude M. Cox, Experimental Designs, Second Edition, John Wiley and Sons, Inc., New York, 1957.
5. Davies, Owen L., Design and Analysis of Industrial Experiments, Second Edition, Hafner Publishing Company, New York, 1967.
6. Anderson, Virgil L., "Design and Optimum Techniques for Consulting Statisticians and Experimenters," unpublished course notes, Purdue University.
7. Kennedy, Thomas W., and W. Ronald Hudson, "Application of the Indirect Tensile Test to Stabilized Materials," Research Report No. 98-1, Center for Highway Research, The University of Texas at Austin, January 1968.
8. Test Method Tex-206-F, Part II, Method of Compacting Test Specimens of Bituminous Mixtures, Vol 1, Manual of Testing Procedures, Texas State Highway Department.
9. Draper, N. R., and H. Smith, Applied Regression Analysis, First Edition, John Wiley and Sons, Inc., New York, 1966.
10. Kozuh, Joseph A., "A New F-Test Strategy for Selecting the Best Regression Equation," Ph.D. Dissertation, The University of Texas at Austin, August 1971.
11. Hondros, G., "The Evaluation of Poisson's Ratio and the Modulus of Materials of a Low Tensile Resistance by the Brazilian (Indirect Tensile) Test with Particular Reference to Concrete," Australian Journal of Applied Science, Vol 10, No. 3, September 1959, pp 243-268.

APPENDIX 1

SUMMARY OF TEST DATA FOR ASPHALT CEMENT



TEST DATA FOR COSDEN ASPHALT CEMENTS  
(Source: Cosden Petroleum Corporation, Big Springs, Texas)

Asphalt	AC-5	AC-10	AC-20
Water, percent	NIL	NIL	NIL
Viscosity at 275 <sup>o</sup> F, Stokes	2.45	2.6	3.6
Viscosity at 140 <sup>o</sup> F, Stokes	773	1,088	2,532
Flash point C.O.C., <sup>o</sup> F	560	570	565
Ductility, 77 <sup>o</sup> F, 5 cm/min, cm	141+	141+	141+
Relative viscosity (after oxidation 15 $\mu$ films for 2 hours at 225 <sup>o</sup> F, viscosities determined at 77 <sup>o</sup> F)	3.87	4.0	2.7
Penetration at 77 <sup>o</sup> F, 100g, 5 sec	112	92	64
Specific gravity at 77 <sup>o</sup> F	1.003	1.006	1.009
Solubility in CCl <sub>4</sub> , percent	99.7+	99.7+	99.7+

## APPENDIX 2

### DISCUSSION OF INDIRECT TENSILE TEST AND TECHNIQUES FOR ESTIMATING TENSILE PROPERTIES

APPENDIX 2. DISCUSSION OF INDIRECT TENSILE TEST AND TECHNIQUES FOR ESTIMATING TENSILE PROPERTIES

THEORY OF THE TEST

The indirect tensile test involves the loading of a circular element with compressive loads acting along two opposite generators (Fig 19). Hondros (Ref 11) developed equations for stresses created in a circular element subjected to short strip loading (Fig 20) assuming that body forces were negligible. These equations for the stresses along the principal diameters are presented below

Stresses Along the Vertical Axis

- (1) Tangential stress (stresses perpendicular to direction of loading):

$$\sigma_{\theta y} = + \frac{2P}{\pi at} \left[ \frac{\left(1 - \frac{r^2}{R^2}\right) \sin 2\alpha}{\left(1 - \frac{2r^2}{R^2} \cos 2\alpha + \frac{r^4}{R^4}\right)} - \tan^{-1} \left( \frac{\left(1 + \frac{r^2}{R^2}\right)}{\left(1 - \frac{r^2}{R^2}\right)} \tan \alpha \right) \right] \quad (A2.1)$$

- (2) Radial stress (stresses parallel to direction of loading):

$$\sigma_{ry} = - \frac{2P}{\pi at} \left[ \frac{\left(1 - \frac{r^2}{R^2}\right) \sin 2\alpha}{\left(1 - \frac{2r^2}{R^2} \cos 2\alpha + \frac{r^4}{R^4}\right)} \right]$$

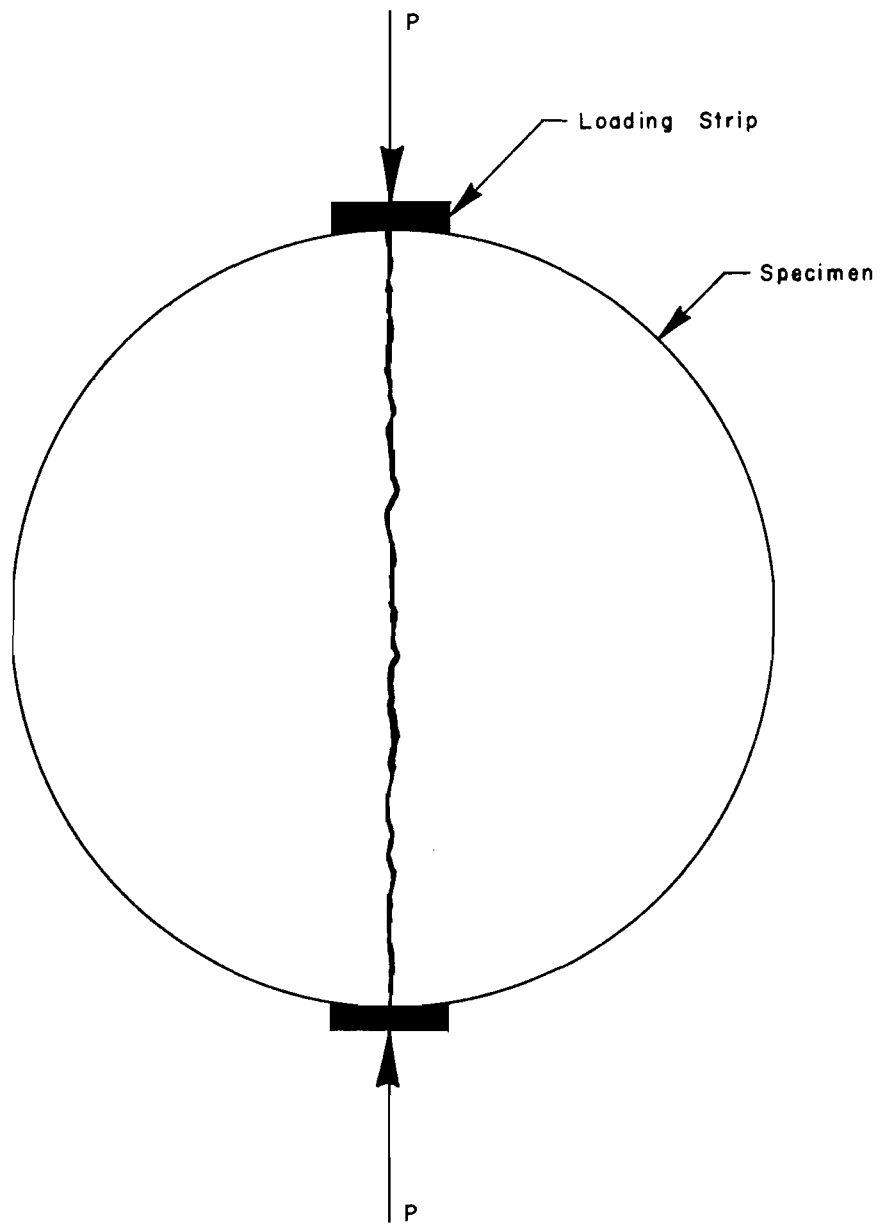

Fig 19. The indirect tensile test.

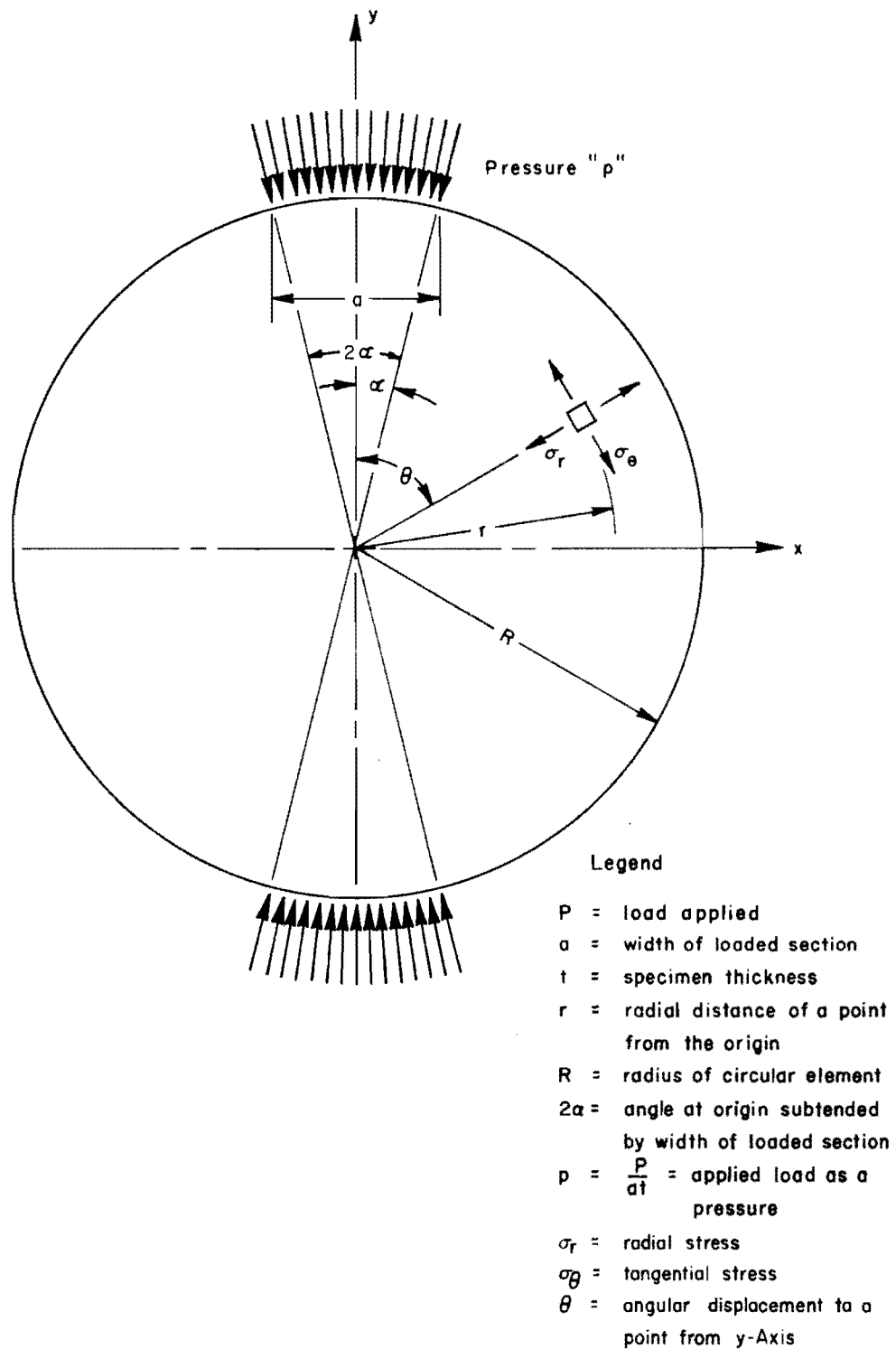

Fig 20. Notation for polar stress components in a circular element compressed by short strip loadings (from Ref 11).

$$+ \tan^{-1} \left( \frac{\left( 1 + \frac{r^2}{R^2} \right) \tan \alpha}{\left( 1 - \frac{r^2}{R^2} \right)} \right) \quad (A2.2)$$

(3) Shear stress:

$$\tau_{r\theta} = 0 \quad (A2.3)$$

### Stresses Along the Horizontal Axis

(1) Tangential stress (stresses parallel to the direction of loading):

$$\sigma_{\theta x} = -\frac{2P}{\pi a t} \left[ \frac{\left( 1 - \frac{r^2}{R^2} \right) \sin 2\alpha}{\left( 1 + \frac{2r^2}{R^2} \cos 2\alpha + \frac{r^4}{R^4} \right)} + \tan^{-1} \left( \frac{\left( 1 - \frac{r^2}{R^2} \right) \tan \alpha}{\left( 1 + \frac{r^2}{R^2} \right)} \right) \right] \quad (A2.4)$$

(2) Radial stress (stresses perpendicular to the direction of loading):

$$\sigma_{rx} = +\frac{2P}{\pi a t} \left[ \frac{\left( 1 - \frac{r^2}{R^2} \right) \sin 2\alpha}{\left( 1 + \frac{2r^2}{R^2} \cos 2\alpha + \frac{r^4}{R^4} \right)} \right]$$

$$- \tan^{-1} \left( \frac{\left( 1 - \frac{r^2}{R^2} \right)}{\left( 1 + \frac{r^2}{R^2} \right)} \tan \alpha \right) \quad (A2.5)$$

(3) Shear stress:

$$\tau_{\theta x} = 0 \quad (A2.6)$$

The stress distributions along the principal planes through the diameters corresponding to the OX and OY-axes for a loading strip width less than D/10 are shown in Fig 21.

#### TEST EQUIPMENT

The basic testing equipment is shown in Fig 22 and consists of an adjustable loading frame, an MTS closed-loop electrohydraulic loading system, and a loading head. The loading frame is a modified, commercially available shoe die with upper and lower platens constrained to remain parallel during testing (Fig 23). It is not necessary to have an MTS loading system for conducting the test. In fact a mechanical screw jack system has also been used extensively. Any loading system with adequate load capacity capable of a vertical loading rate of approximately 2.0 inches per minute can be utilized.

The vertical deformation of the specimen is measured by a DC linear variable-differential transducer which is also used to control the rate of load application by providing an electrical signal related to the relative movements of the upper and lower platens. The measurements are recorded on an x-y plotter.

Horizontal deformations of the test specimen are obtained through the use of a measuring device consisting of two cantilevered arms with strain gages attached, as shown in Fig 24. Movements or deflections of the arms at the point of contact with the specimen have been calibrated with the output from the strain gages. The horizontal measurements are recorded on an x-y plotter.

Stainless steel curved loading strips were used in the indirect tensile test. The dimensions and configuration of the loading strip used are shown in Fig 25.

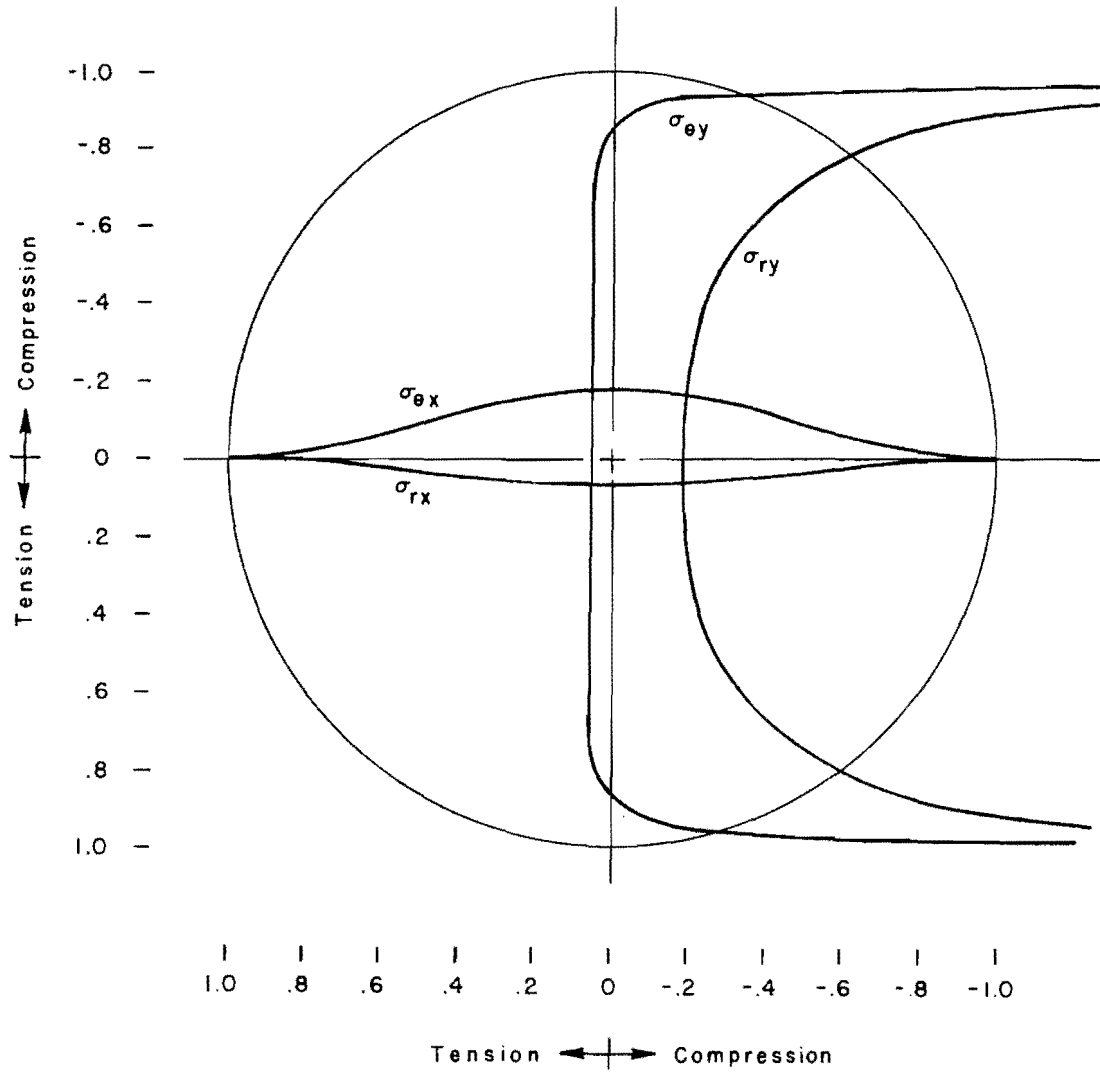

Fig 21. Stress distribution along the principal axes for loading strip width (a) less than  $D/10$ .  $2p/\pi = 1$



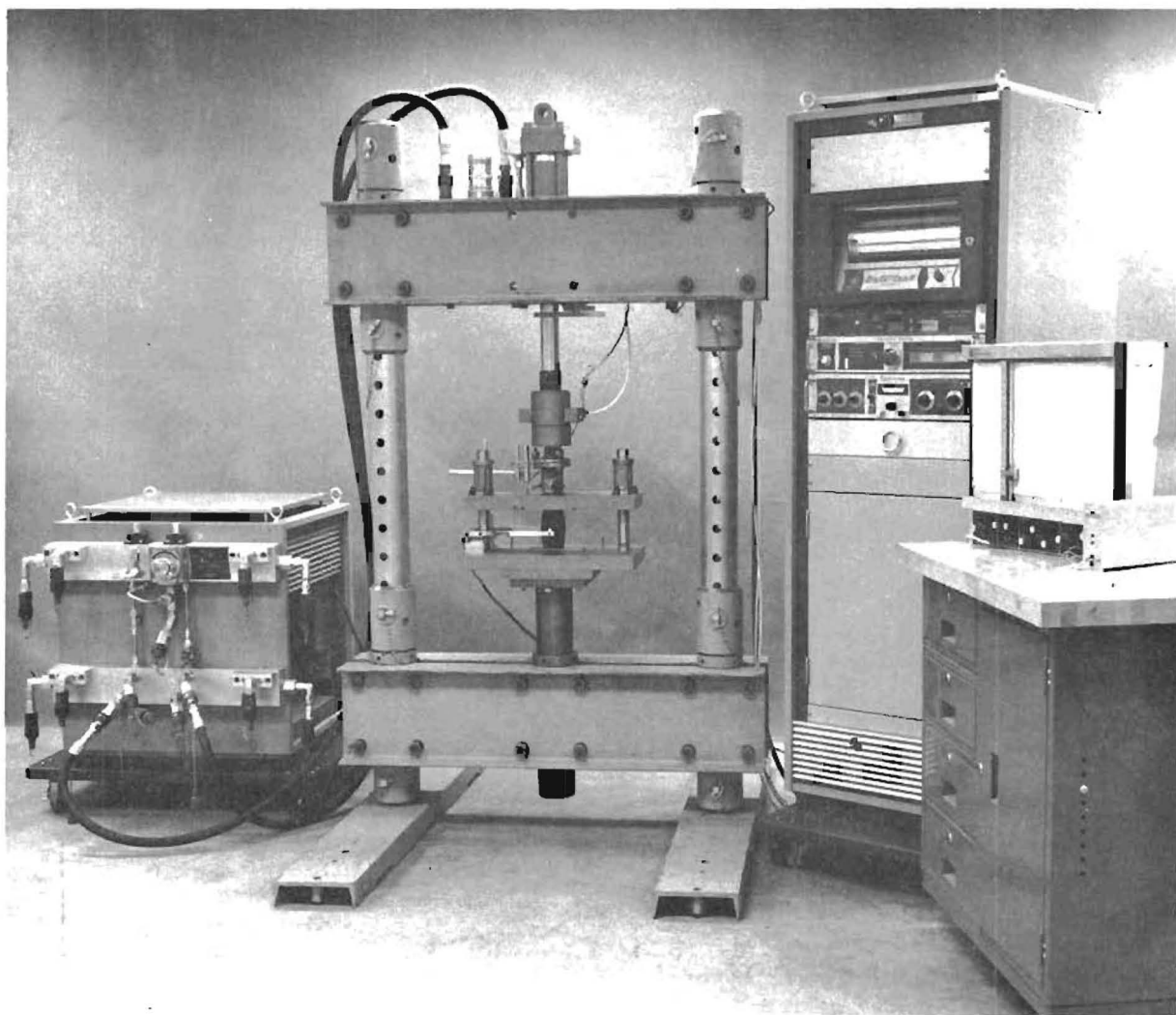

Fig 22. Basic indirect tensile testing equipment.

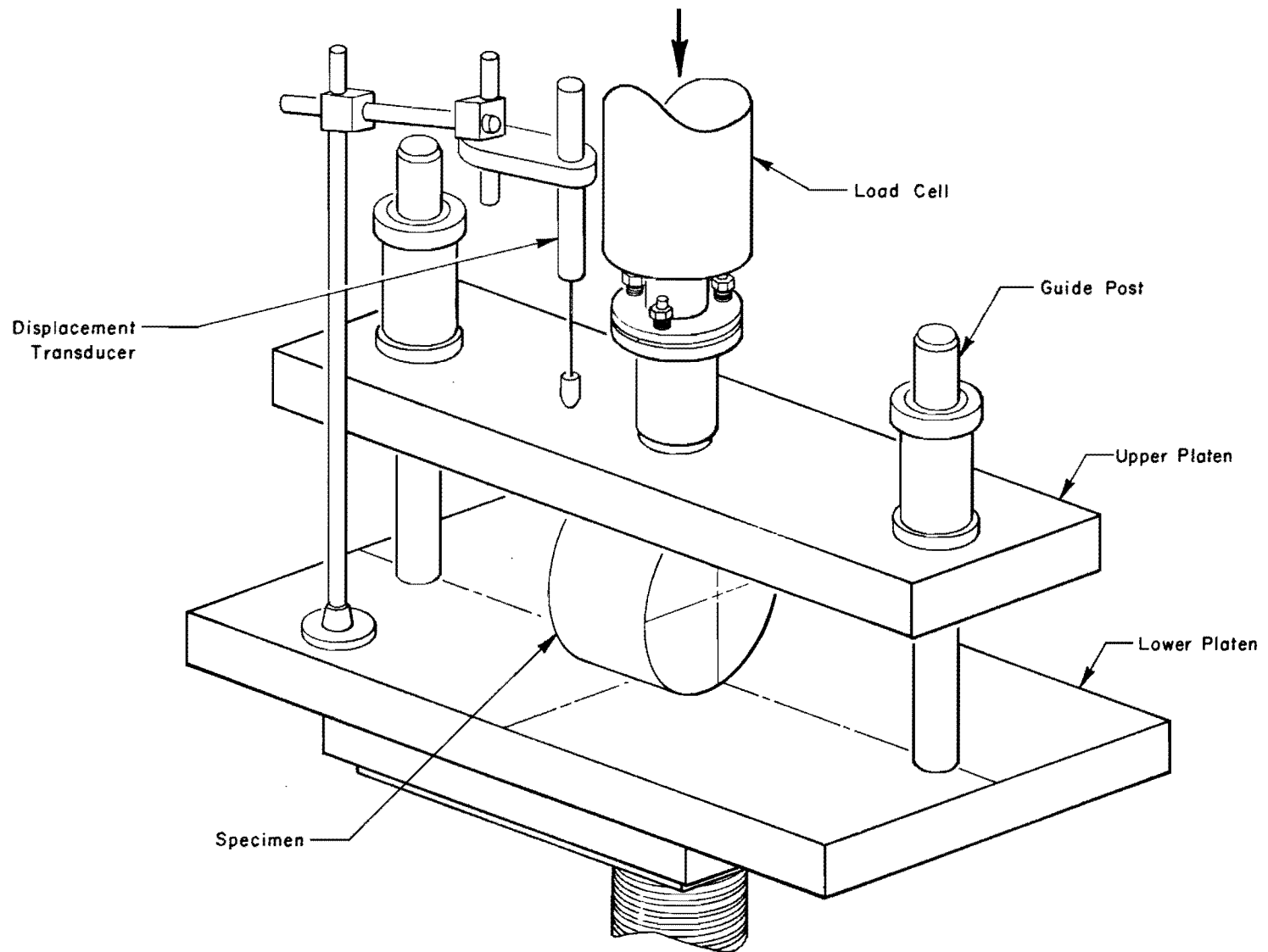

Fig 23. Loading head with rigid parallel platens.

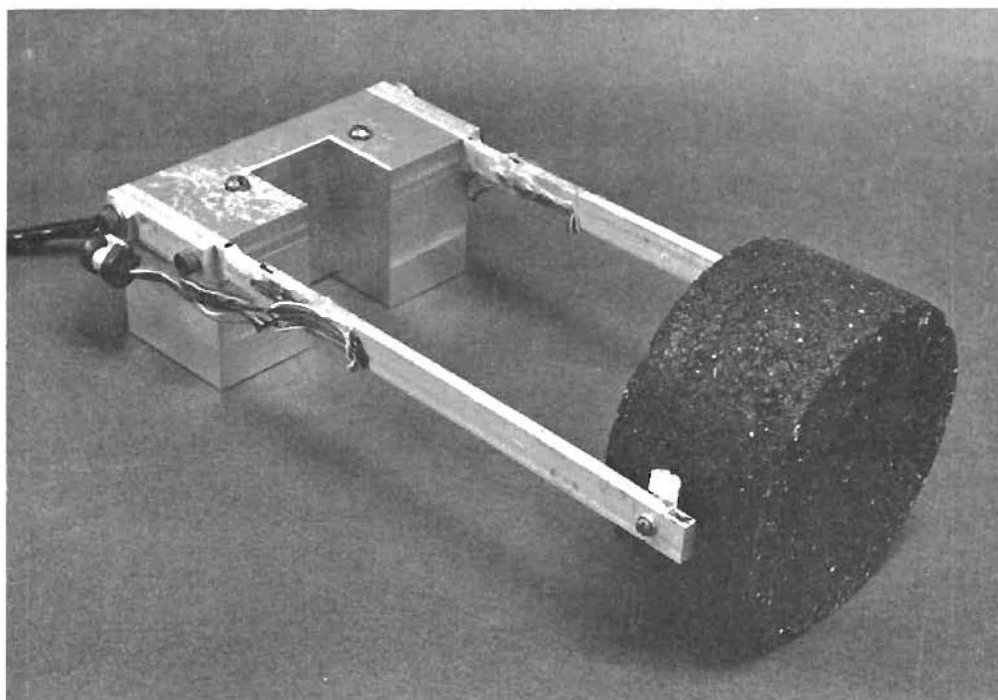
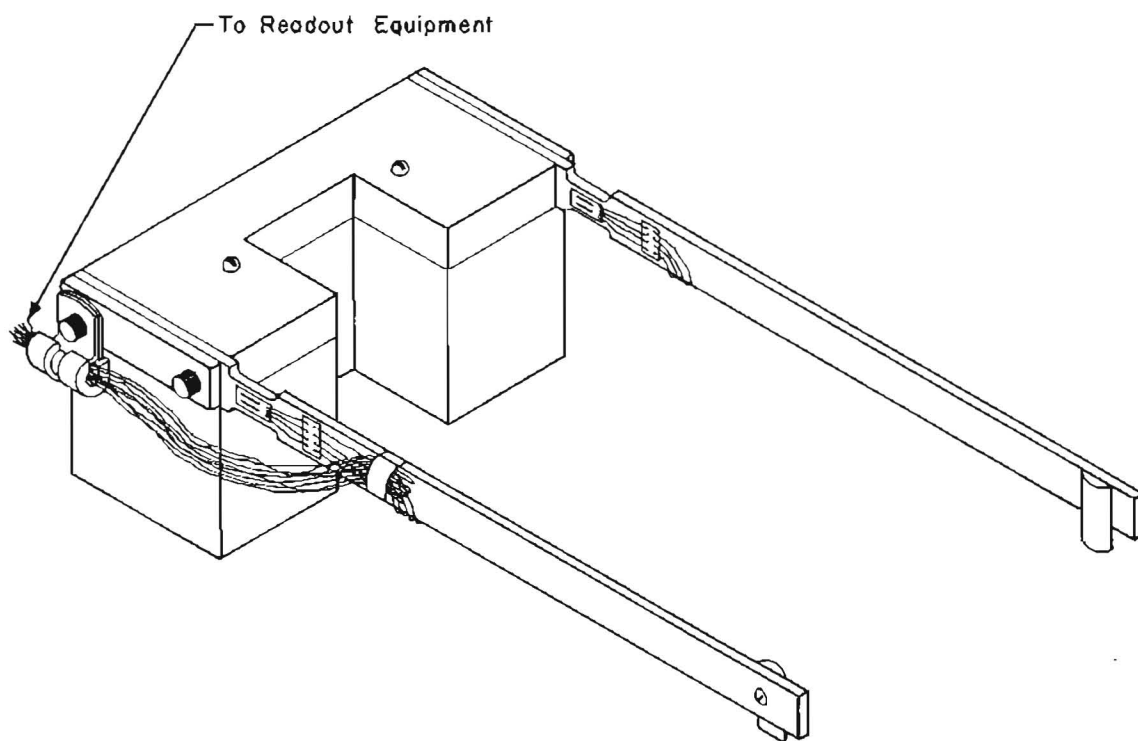

Fig 24. Lateral-strain measuring device.

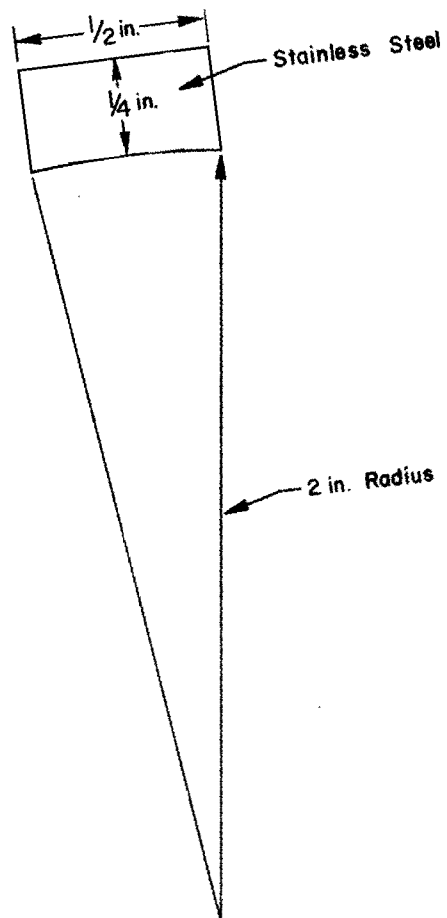

Fig 25. General configuration - stainless steel loading strip.

## TECHNIQUE FOR ESTIMATING TENSILE PROPERTIES

The parameters evaluated in this study were

- (1) modulus of elasticity,
- (2) Poisson's ratio,
- (3) tensile strength,
- (4) total tensile strain at failure, and
- (5) elastic tensile strain at failure.

Values for these parameters were calculated by the following equations.

### Modulus of Elasticity E

$$E = \frac{P}{X} \left[ \int_{-r}^{+r} \frac{\sigma_{rx}}{P} - \nu \int_{-r}^{+r} \frac{\sigma_{\theta x}}{P} \right] \quad (\text{A2.7})$$

where

$\frac{P}{X}$  = the least squares line of best fit between load P and total horizontal deformation, X for loads up to 50 percent of the load P<sub>MAX</sub> at which the first break point occurs in the load deflection curve (see Fig 26);

$\nu$  = Poisson's ratio,

$\int_{-r}^{+r} \frac{\sigma_{rx}}{P}$  and  $\int_{-r}^{+r} \frac{\sigma_{\theta x}}{P}$  = the integration of the unit stresses  $\sigma_{rx}$  and  $\sigma_{\theta x}$

### Poisson's Ratio $\nu$

$$\nu = \frac{\left[ \int_{-r}^{+r} \sigma_{ry} + R \int_{-r}^{+r} \sigma_{rx} \right]}{\left[ R \int_{-r}^{+r} \sigma_{\theta x} + \int_{-r}^{+r} \sigma_{\theta y} \right]} \quad (\text{A2.8})$$

where

$$\int_{-r}^r \sigma_{ry} \text{ and } \int_{-r}^r \sigma_{rx} = \text{integration of radial stresses in the } y \text{ and } x\text{-directions, respectively;}$$

$$\int_{-r}^r \sigma_{\theta x} \text{ and } \int_{-r}^r \sigma_{\theta y} = \text{integration of radial stresses in the } x \text{ and } y\text{-directions, respectively; and}$$

$$R = \frac{Y}{X} = \text{the least square line of best fit between vertical deformation } Y \text{ and the corresponding horizontal deformation } X \text{ up to } P_{MAX} \text{ (First Break Point).}$$

### Tensile Strength $S_T$

From equation A2.1 or A2.5 the tensile stress perpendicular to the applied load at the center of the specimen ( $r = 0$ ) can be

$$S_T = \frac{2P_{MAX}}{\pi ah} \left( \sin 2\alpha - \frac{a}{2R} \right) \quad (\text{A2.9})$$

where

$P_{MAX}$  = the load at the first inflection point of the load horizontal deformation curve (see Fig 26),

$a$  = the width of the loading strip (see Fig 20),

$h$  = the height of the specimen, and

$\alpha$  = the angle in radians subtended by one-half the width of loading strip  $a$  (see Fig 20).

### Total Tensile Strain at Failure $\epsilon_T$

$$\epsilon_T = \frac{X_{TF}}{l} \frac{\left[ \int_{-\frac{l}{2}}^{+\frac{l}{2}} \frac{\sigma_{rx}}{P} - \nu \int_{-\frac{l}{2}}^{+\frac{l}{2}} \frac{\sigma_{\theta x}}{P} \right]}{\left[ \int_{-r}^{+r} \frac{\sigma_{rx}}{P} - \nu \int_{-r}^{+r} \frac{\sigma_{\theta x}}{P} \right]} \quad (\text{A2.10})$$

where

$X_{TF}$  = total horizontal deformation at PMAX or first break point (see Fig 26),

$l$  = length over which strain is estimated ( $l = .004$  for this study),

$\nu$  = Poisson's ratio, and

$\frac{\sigma_x}{P}$ ,  $\frac{\sigma_{\theta x}}{P}$ ,  $\frac{\sigma_{ry}}{P}$ , and  $\frac{\sigma_{\theta y}}{P}$  = integration of unit stresses (completed numerically in a computer).

Elastic Tensile Strain at Failure  $e_E$

$$e_E = \frac{X_{EF}}{l} \frac{\left[ \int_{-\frac{l}{2}}^{\frac{l}{2}} \frac{\sigma_{rx}}{P} - \nu \int_{-\frac{l}{2}}^{\frac{l}{2}} \frac{\sigma_{\theta x}}{P} \right]}{\left[ \int_{-r}^r \frac{\sigma_{rx}}{P} - \nu \int_{-r}^{+r} \frac{\sigma_{\theta x}}{P} \right]} \quad (A2.11)$$

where

$X_{EF}$  = the elastic deformation at failure and is equal to  $\frac{P_{MAX}}{\left(\frac{P}{X}\right)}$

with  $\left(\frac{P}{X}\right)$

load and horizontal deformation. (This is presented pictorially in Fig 26.)

#### METHOD FOR ANALYSIS

- (1) The load-deformation curves are obtained from indirect tensile test (see example plots in Figs 27 through 30).
- (2) Compute slope of least squares line of best fit between Y and X at corresponding loads and calculate Poisson's ratio. The integration of the stresses is completed in a computer.
- (3) Compute slope of least squares line of best fit between load and horizontal deformation up to loads of 50 percent of PMAX and calculate modulus of elasticity value (integrated stresses and Poisson's ratio have been previously calculated).

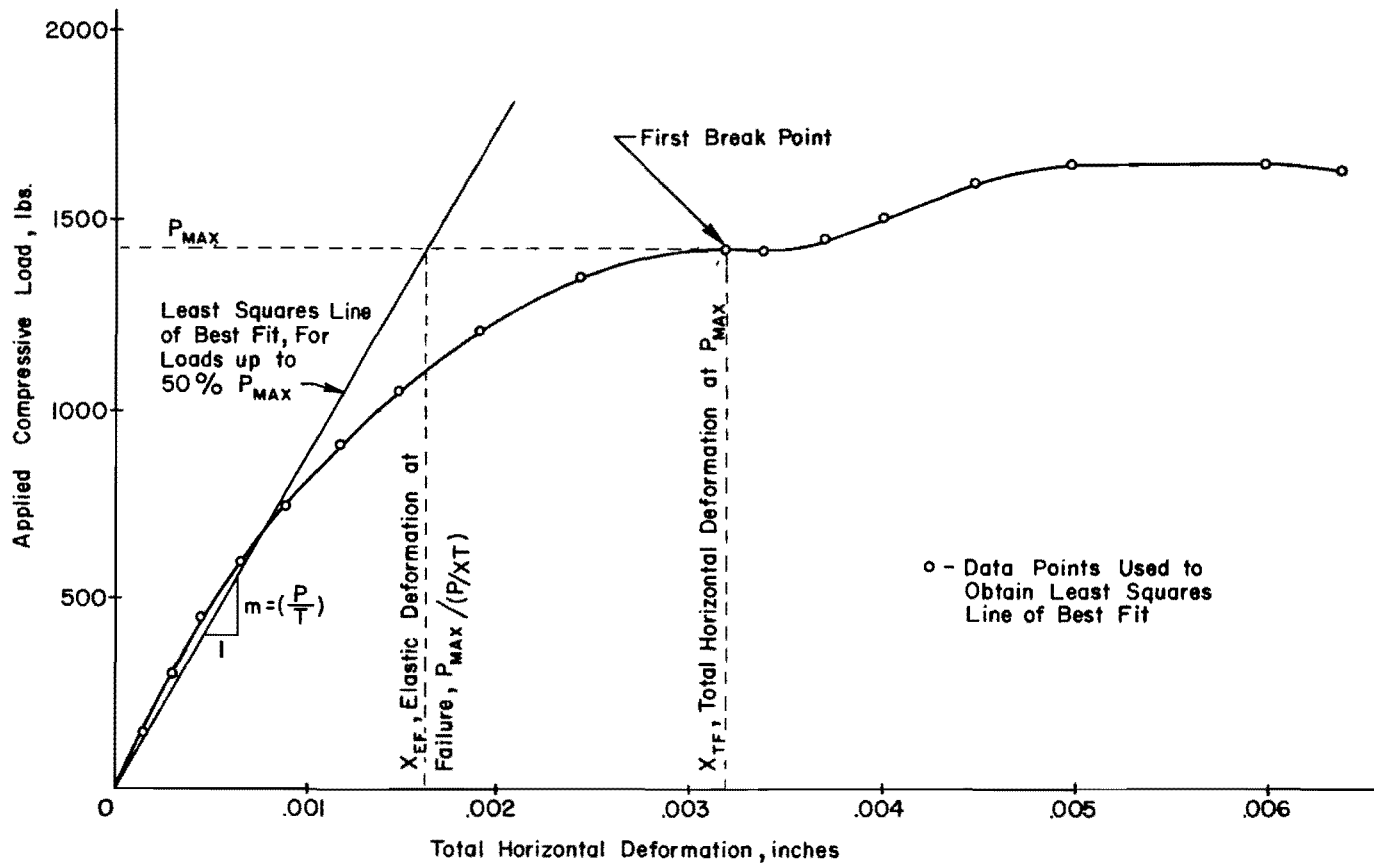

Fig 26. Generalized characterization of load-horizontal deformation data.



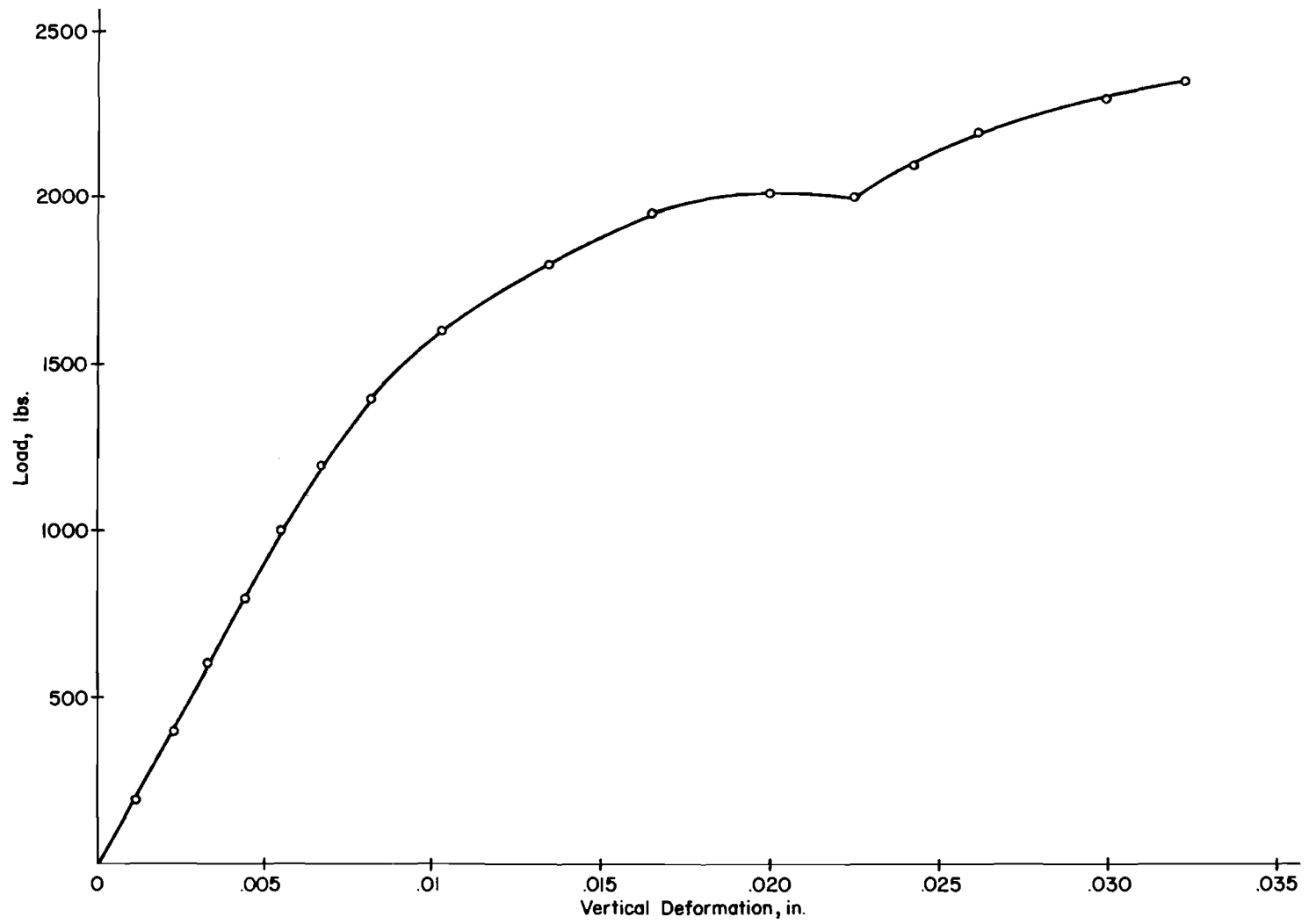

Fig 27. Load-verticle deformation curve: Specimen no. 17.

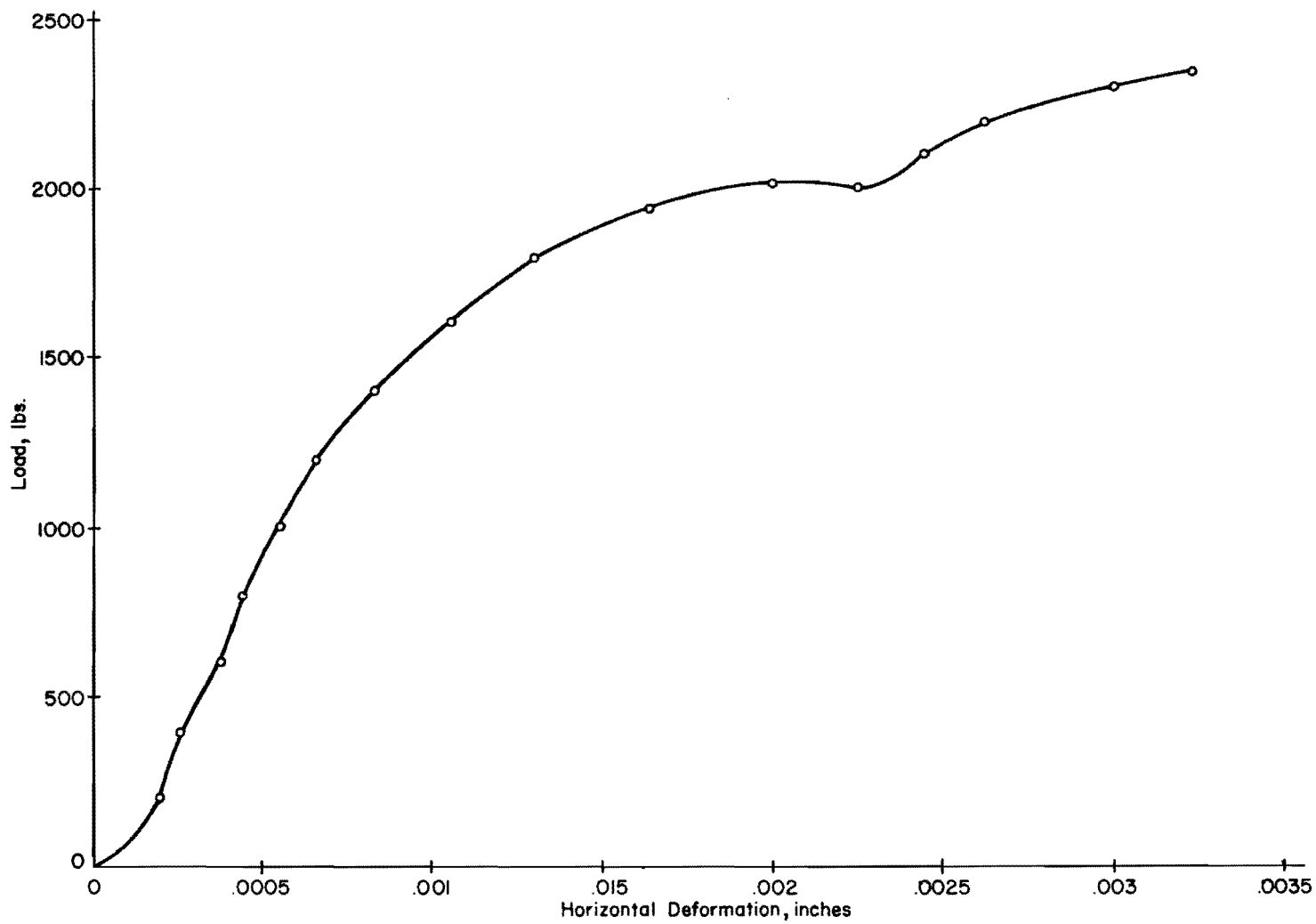

Fig 28. Load-horizontal deformation curve: Specimen no. 17.

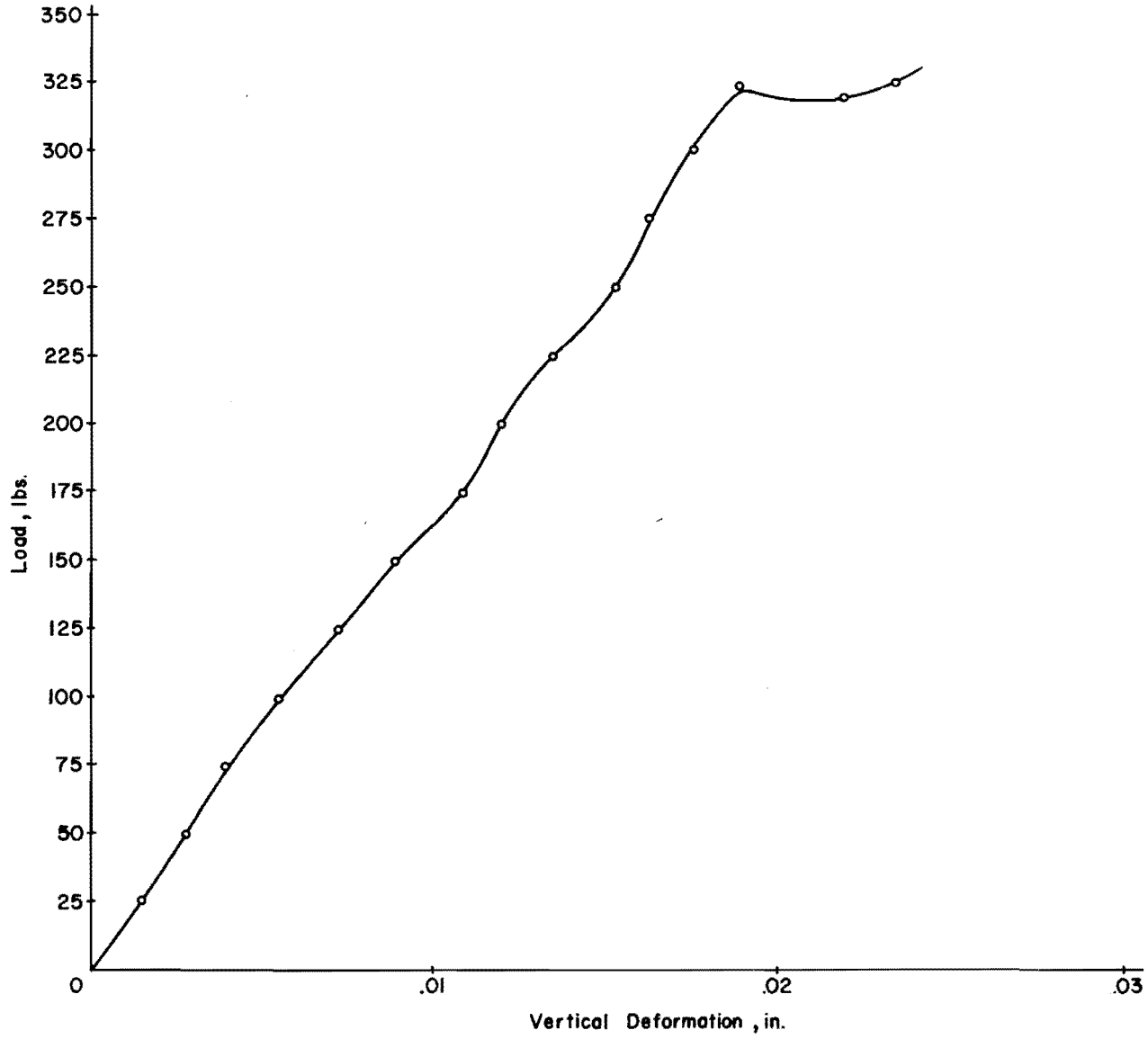

Fig 29. Load-verticle deformation curve: Specimen No. 36.

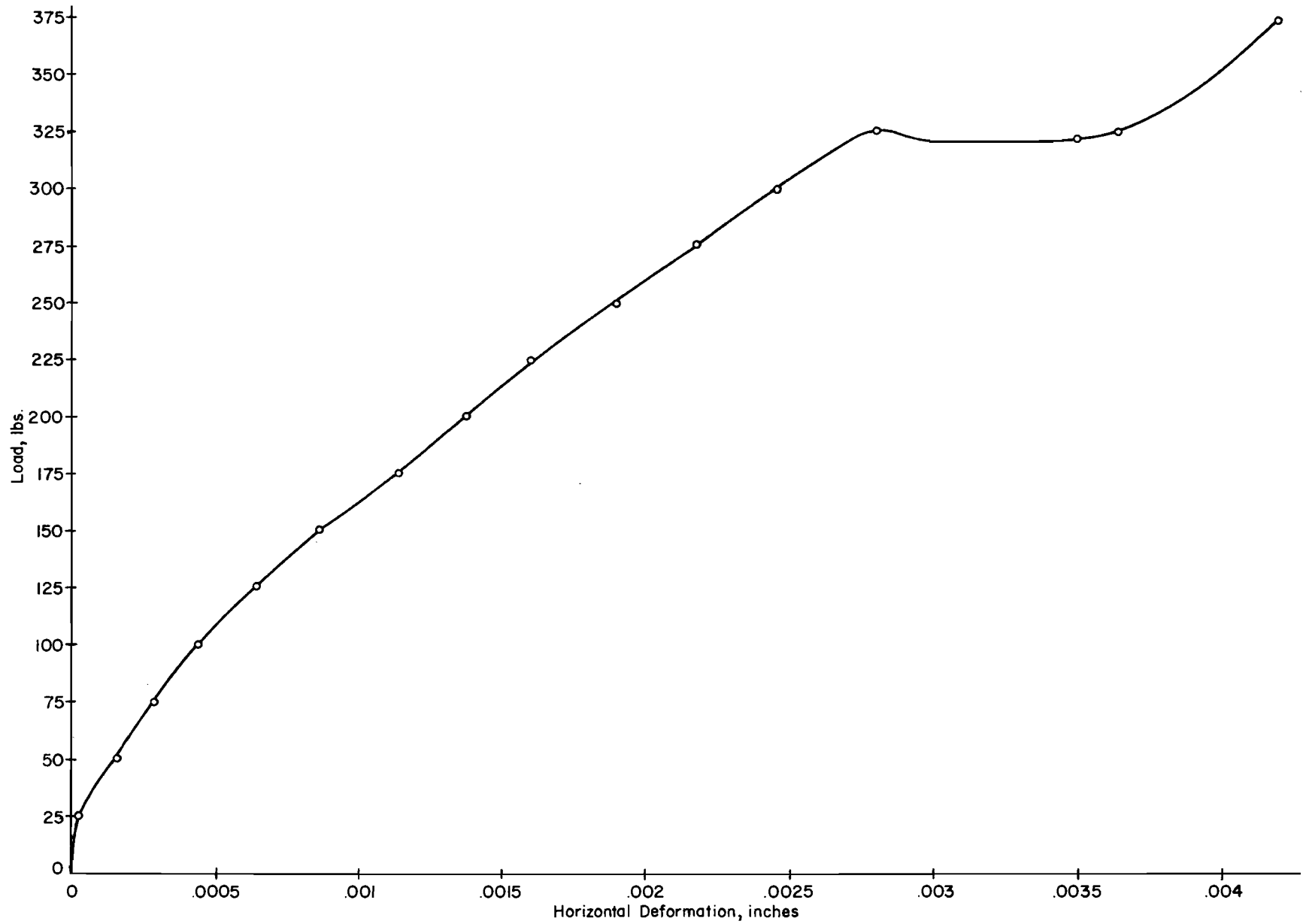

Fig 30. Load-horizontal deformation curve: Specimen no. 36.

- (4) Calculate tensile strength.
- (5) Obtain total horizontal deformation at failure, establish a length over which an estimate is made (.001 for this study), and determine total tensile strain at failure.
- (6) Using slope between load and horizontal deformation up to 50 percent P<sub>MAX</sub> previously obtained (Step 3), calculate elastic tensile strain at failure.

#### APPLICATION OF TECHNIQUE

The methods are shown here for two different test specimens. The two specimens indicated as No. 17 and No. 36 include the following factors:

<u>Factors</u>	<u>Specimen No. 17</u>	<u>Specimen No. 36</u>
Aggregate type	limestone	limestone
Aggregate gradation	coarse	coarse
Asphalt cement type	AC5	AC5
Asphalt content	5.5%	7.0%
Mixing temperature	250° F	250° F
Compaction temperature	200° F	200° F
Curing temperature	110° F	75° F

The load deflection plots for these specimens are included in Figs 27 through 30. Vertical deformation data have been plotted versus horizontal deformation for both specimens and are included in Fig 31.

The step-by-step procedure for the two specimens is indicated below:

- (1) See Figs 27 through 30.
- (2) Determine least squares line of best fit between Y and X ( $DR = \frac{Y}{X}$ ):

DR = 10.97 for specimen No. 17 (see Fig 31), and

DR = 6.55 for specimen No. 36 (see Fig 31).

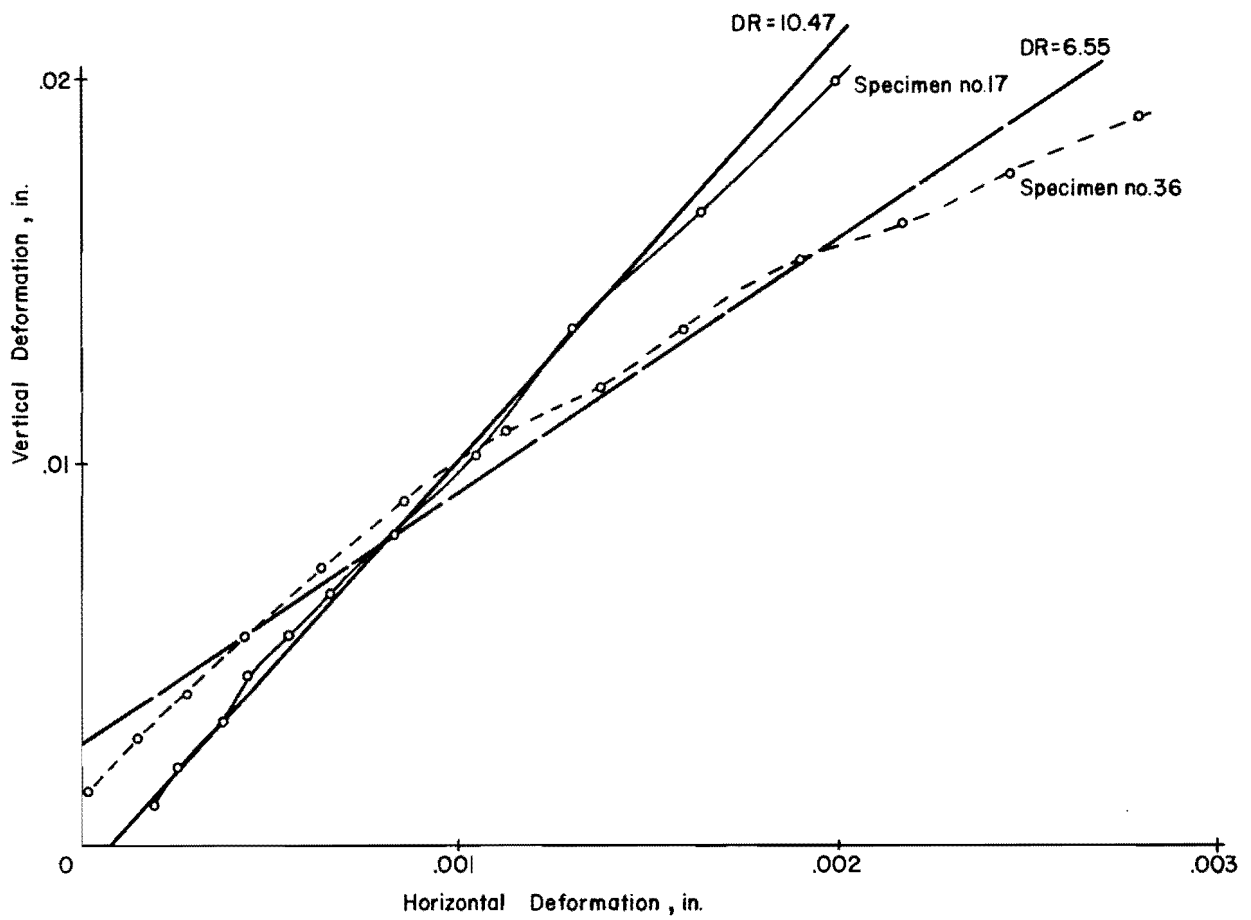

Fig 31. Vertical deformation versus horizontal deformation:  
Specimen nos. 17 and 36.

From computer results

$$\int_{-r}^{+r} \sigma_{ry} = - \frac{3.5816P}{h}$$

$$\int_{-r}^{+r} \sigma_{rx} = + \frac{.2692P}{h}$$

$$\int_{-r}^{+r} \sigma_{\theta x} = - \frac{.9976P}{h}$$

$$\int_{-r}^{+r} \sigma_{\theta y} = - \frac{.0624P}{h}$$

Poisson's ratio  $\nu$  for specimen No. 17 = 0.057, and

Poisson's ratio  $\nu$  for specimen No. 36 = 0.276.

(3) Determine  $\left(\frac{P}{X}\right)$  and calculate modulus of elasticity:

$\frac{P}{X}$  for specimen No. 17 =  $1.867 \times 10^6$  lb/in, and

$\frac{P}{X}$  for specimen No. 36 =  $1.642 \times 10^5$  lb/in.

$$E = \left(\frac{P}{X}\right) \left(\frac{1}{h}\right) \left[.2692 + .9976\nu\right]$$

For specimen No. 17,  $E = 3.056 \times 10^5$  psi, and

for specimen No. 36,  $E = 4.514 \times 10^4$  psi.

(4) Calculate tensile strength:

$$S_T = \frac{2P_{MAX}}{\left(\frac{\pi}{2}\right) (h)} (.1222) = 0.1556 \frac{P_{MAX}}{t}$$

	Specimen No. 17	Specimen No. 36
P <sub>MAX</sub>	2,015 lbs	325 lbs
a	1/2	1/2
h	1.995 in	1.980 in
2α	14.291°	14.291°
α	0.1247 radian	0.1247 radian
S <sub>T</sub>	157.2	25.5

(5) Determine total tensile strain:

Total horizontal deformation at failure = .002000 for specimen No. 17, and

Total horizontal deformation at failure = .00280 for specimen No. 36.

$$\int_{-.002}^{+.002} \frac{\sigma_{rx}}{P} = + \frac{6.2340 \times 10^{-4}}{h}$$

$$\int_{-.002}^{+.002} \frac{\sigma_{\theta x}}{P} = - \frac{1.89664 \times 10^{-3}}{h}$$

$$\int_{-r}^{+r} \frac{\sigma_{rx}}{P} = + \frac{2.692 \times 10^{-1}}{h}$$

$$\int_{-r}^{+r} \frac{\sigma_{\theta x}}{P} = - \frac{9.976 \times 10^{-1}}{h}$$

$$\epsilon_T = \frac{X_{TF}}{.004} \left[ \frac{6.234 \times 10^{-4} + 1.8966 \times 10^{-3} v}{.2692 + .9976 v} \right] \quad (A2.12)$$

For specimen No. 17

$$\epsilon_T = X_{TF} [0.560] = 1.120 \times 10^{-3} \quad (A2.13)$$



For specimen No. 18

$$\epsilon_T = X_{TF} [0.526] = 1.470 \times 10^{-3} \quad (\text{A2.14})$$

(6) Determine elastic tensile strain at failure:

$$\epsilon_E = \frac{X_{EF}}{X_{TF}} \epsilon_T \quad (\text{A2.15})$$

where

$$X_{EF} = \frac{P_{MAX}}{\left(\frac{P}{X}\right)}$$

For specimen No. 17

$$X_{EF} = \frac{2015.}{1.067 \times 10^6} = 1.079 \times 10^{-3} \quad (\text{A2.16})$$

For specimen No. 36

$$X_{EF} = \frac{325.}{1.642 \times 10^5} = 1.979 \times 10^{-3} \quad (\text{A2.17})$$

For specimen No. 17

$$\epsilon_E = (1.079 \times 10^{-3})(0.560) = 0.604 \times 10^{-3} \quad (\text{A2.18})$$

For specimen No. 36

$$\epsilon_E = (1.979 \times 10^{-3})(0.526) = 1.041 \times 10^{-3} \quad (\text{A2.19})$$

## APPENDIX 3

### PHASING ANALYSIS AND EXPERIMENTAL ERROR EVALUATION

### APPENDIX 3. PHASING ANALYSIS AND EXPERIMENTAL ERROR EVALUATION

The preparation and testing procedures are actually composed of the three distinct phases of (1) mixing, (2) compaction, and (3) curing. In the mixing phase five of the total number of factors are introduced in the experimental process. Those factors involved are aggregate type, aggregate gradation, asphalt type or viscosity, asphalt content and mixing temperature. The errors introduced during the mixing phase exclusive of true error\* are then related to these five factors. Slight differences in the mixing phase variables such as gradation, asphalt content, or mixing temperature from the established fixed levels could easily occur thereby introducing additional experimental errors in the results.

Another factor, compaction temperature, is added during the compaction phase possibly creating additional experimental errors attributable to this new factors as well as to interaction involving the added variable and the five factors introduced during the mixing phase. The experimental error then in the compaction phase includes true error, the errors due to mixing, and the errors due to compaction.

The final factor, curing temperature, is introduced in the curing phase. The errors in the experimental data at the completion of the overall process include true error and the errors for all three phases which are related to all seven factors and their interactions.

The errors for each phase can then be synthesized by accumulating errors as shown in Table 17 where  $\sigma_I^2$ ,  $\sigma_{II}^2$ , and  $\sigma_{III}^2$  are the error variances for the mixing, compaction, and curing phases, respectively, and  $\sigma_m^2$ ,  $\sigma_{co}^2$ , and  $\sigma_{cu}^2$  are the error variances for mixing, compaction, and curing variables, respectively. The experimental error variance  $\sigma_e^2$  is the variation which occurs between replicate specimens regardless of phasing or testing period is included in all phases of the experiment.

---

\* The true error is defined as the random error which arises from causes inherent in the analytical method, i.e., error which would be expected when testing duplicate specimens in the same time period under same test conditions.

TABLE 17. EXPECTED ERROR VARIANCE

<u>Phase</u>	<u>Error Variance</u>
Curing	$\sigma_{III}^2 = \sigma_e^2 + \sigma_m^2 + \sigma_{co}^2 + \sigma_{cu}^2$
Compaction	$\sigma_{II}^2 = \sigma_e^2 + \sigma_m^2 + \sigma_{co}^2$
Mixing	$\sigma_I^2 = \sigma_e^2 + \sigma_m^2$
<hr/>	
Experimental Error	$\sigma_e^2$

The concept of experimental error variance is based primarily upon what is known as day-to-day variation. The experimental error variance is generally considered to be a function of the true error variance and day-to-day variation. Estimates of true error variance are obtained from duplicate specimens tested within the same time period, i.e., hour or day, while estimates of the experimental error variance are obtained from replicate specimens tested in separate time periods. Thus, experimental error variance estimates take into consideration such day-to-day variations as changes in equipment, power to equipment, equipment operation, testing techniques, operating personnel, etc., and provide a variance with a broader inference which can be used in future experiments with good reliability.

In the phasing evaluation, the estimate of true error variance or duplicate error will be used as an estimate of experimental error variance because it was felt that day-to-day variations were small and could be neglected.

It was, however, considered of great importance particularly for analysis of variance and regression analysis to determine if there was any day-to-day variations in the test data as indicated by errors associated with the data. Therefore, the phasing experiment was so arranged that this evaluation could be made. These comparisons are included in the latter part of this section.

The errors are indicated by standard nomenclature of variance which in simple terms is  $\sigma^2 = \frac{\sum_{n=1}^n (X_i - \bar{X})^2}{n}$  where  $X_i$  are the values of the response, i.e., modulus, tensile strength, strain,  $\bar{X}$  the mean of the  $n$  response values; and  $n$  the number of particular responses evaluated. The variance then is a measure of the variation about the mean value of some particular effect, in these cases, mixing, compaction, and curing variables.

The relative magnitude of the errors introduced at the different phases governs the type of analysis required to evaluate the experimental data. There are generally two hypotheses which can be proffered regarding the errors in the three phases. They are that

$$(1) \quad \sigma_m^2 = \sigma_{co}^2 = \sigma_{cu}^2 = \emptyset, \text{ and}$$

$$(2) \quad \sigma_m^2 \neq \sigma_{co}^2 \neq \sigma_{cu}^2 \neq \emptyset.$$

If the first case is proper, the errors associated with each of the phases,  $\sigma_I^2$ ,  $\sigma_{II}^2$ ,  $\sigma_{III}^2$ , would have to be relatively constant and equal approximately to experimental error variance,  $\sigma_e^2$  (i.e., no additional error due to phases). From Table 17, in this case, then the experimental error variance  $\sigma_e^2$  is the error variance for all three phases allowing it to be used to evaluate all variables regardless of phase. This type analysis is the same as that used for a completely randomized experiment.

If, on the other hand, the second hypothesis is correct, then the error variance would change from phase to phase. A different experimental error variance other than  $\sigma_e^2$  would be required to evaluate the variable involved with each phase, i.e.,  $\sigma_{III}^2$  would be experimental error used to evaluate the curing variable;  $\sigma_{II}^2$  to evaluate compaction variable; and  $\sigma_I^2$  to evaluate the mixing variables. This second type analysis is generally considered to be a split-plot analysis (Ref 10).

Once the numerical values of  $\sigma_I^2$ ,  $\sigma_{II}^2$ , and  $\sigma_{III}^2$  for the three phases are determined, some technique must be used to evaluate the proper hypothesis. Using a logical approach the existence of error due to mixing could be evaluated from results by determining the ratio between  $\sigma_I^2$ , the error variance for mixing phase, and the estimate of experimental error variance,  $\sigma_e^2$ . If  $\sigma_m^2 = \emptyset$ , then the ratio should be close to 1, while if  $\sigma_m^2 \neq 0$ , the ratio would be greater than 1. This presents a dilemma since a value of this ratio must be established above which there are considered to be additional errors created during mixing. In other words, if the ratio is 1.1, 1.2, or 1.5, could a rational decision be made as to the existence of error due to mixing? For this type analysis one must select or establish some method or technique with which some confidence can be stated for his decision. In this particular study a statistical technique for evaluating variances by F probability distribution was used. The F ratio used in the technique is, in fact, the ratio discussed above. From tabled data  $F_t$  ratios which can be used to assign some probability to the hypothesis that two particular variances are equal, can be selected to compare with actual  $F_a$  ratio values obtained from experimental results. The value of  $F_t$  ratio for which there is a significant difference between two variances (at some particular probability level) is called the critical  $F_{cr}$  value and indicates with some selected

probability that value of  $F_t$  at which the experimenter can say that there is a significant difference in the variances or that the variances are apparently not equal.

A second technique used in this particular portion of the study was the pooling of variances. If from the  $F$  test there was found to be no significant difference between the estimate of experimental error variance and error variance, for example, the mixing phase at some preselected probability level (in this study  $\alpha = 0.25$ ), then the two can be pooled or combined to provide a more robust error variance with which to test the error variance for compaction phase. A similar pooling process can also be completed if there is no significant difference between pooled error variance for mixing phase and the error variance for the compaction phase. The results of the phasing analysis can be seen in Tables 18 through 20 for each of the parameters phase by phase.

The phasing evaluation shows then that there was apparently no difference between the experimental error variance obtained from duplicate error (in this case, estimate of true error variance) and error variance in the three phases for the parameters, modulus of elasticity, Poisson's ratio, and tensile strength. Thus, these parameters could be analyzed as if the experiment were a completely randomized experiment, and the estimate of experimental error variance was to evaluate all linear and nonlinear effects due to the seven factors evaluated in this study.

In the case of tensile failure strain there was no difference between the estimated error variances, i.e.,  $\sigma_I^2$ ,  $\sigma_{II}^2$ ,  $\sigma_{III}^2$ , for the three phases; however, there was a difference between the estimated experimental error variance which was assumed to be equal to estimate of true error variance, and the error variance for the mixing phase.

It must be stated here that the critical  $F$  value,  $F_{cr}$  and experimental  $F_a$  value were very close indeed ( $F_{cr} = 1.40$  and  $F_a = 1.42$ ), and that the engineer may well be inclined to say that there is no particular difference between the two  $F$  values. However, in this study, the critical  $F$  value was used as the limiting value; therefore, the conclusion was that there was a difference between the estimate of experimental error variance and the duplicate error variance for the mixing phase. A comparison of the two variances ( $\sigma_e^2 = 0.105 \times 10^{-6}$ ;  $\sigma_I^2 = 0.150 \times 10^{-6}$ ) indicates the difference.

There were two explanations considered for this difference. First of all, the difference indicated that the error variance due to the mixing variable

TABLE 18. EVALUATION OF MIXING PHASE

Parameter	Estimated True Error		Estimated Error Mixing Phase		Calculated F Value F=Col 4/Col 2	Critical F Value FCr( $\sigma = .25$ )	Can $\sigma_e^2$ and $\sigma_I^2$ be Pooled (if $F < F_{Cr}$ )	Pooled Results Mixing Phase Error Variance		Comments Concerning Error Variance for Future Eval.
	Variance	df	Variance	df				$\sigma_{Ip}^2$	df <sub>Ip</sub>	
	$\sigma_e^2$	df <sub>e</sub>	$\sigma_I^2 = \sigma_e^2 + \sigma_m^2$	df <sub>I</sub>						
Modulus of Elasticity	$0.699 \times 10^{10}$	15	$0.562 \times 10^{10}$	25	0.84	1.40	Yes $0.84 < 1.40$	$0.620 \times 10^{10}$	40	$\sigma_m^2 = \emptyset$ Use pooled error variance $\sigma_{Ip}^2$ to evaluate compaction phase
Poisson's Ratio	.0163	15	.0155	25	0.95	1.40	Yes $0.95 < 1.40$	.0158	40	$\sigma_m^2 = \emptyset$ Use pooled error variance $\sigma_{Ip}^2$ to evaluate compaction phase
Tensile Strength	405.13	15	459.59	25	1.13	1.40	Yes $1.13 < 1.40$	439.170	40	$\sigma_m^2 = \emptyset$ Use pooled error variance $\sigma_{Ip}^2$ to evaluate compaction phase
Total Tensile Strain at Failure	$0.1051 \times 10^{-6}$	15	$0.1495 \times 10^{-6}$	25	1.42	1.40	No $1.42 > 1.40$	-	-	$\sigma_m^2 = \emptyset$ Use mixing phase error variance $\sigma_I^2 = 0.1495 \times 10^{-6}$ to evaluate compaction phase
Estimated Elastic Tensile Strain at Failure	$3.433 \times 10^{-8}$	15	$2.796 \times 10^{-8}$	25	0.81	1.40	Yes $0.81 < 1.40$	$3.036 \times 10^{-8}$	40	$\sigma_m^2 = \emptyset$ Use pooled error variance $\sigma_{Ip}^2$ to evaluate compaction phase



TABLE 19. EVALUATION OF COMPACTION PHASE

Parameter	Estimated Mixing Phase Error		Estimated Comp. Phase Error		Calculated F Value F=Col 4/Col 2	Critical F Value FCr(σ=.25)	Can $\sigma_I^2$ and $\sigma_{II}^2$ be pooled (if $F < F_{Cr}$ )	Pooled Results Comp. Phase Error Variance		Comments Concerning Error Var. for Future Evaluation
	$\sigma_I^2$	df <sub>I</sub>	$\sigma_{II}^2 = \sigma_I^2 + \sigma_{co}^2$	df <sub>II</sub>				$\sigma_{IIp}^2$	df <sub>IIp</sub>	
Modulus of Elasticity	$0.620 \times 10^{10}$ (p)*	40	$0.477 \times 10^{10}$	16	0.77	1.30	Yes 0.77 < 1.30	$0.567 \times 10^{10}$	56	Use pooled var. $\sigma_{IIp}^2$ to evaluate curing phase $\sigma_m^2 = \sigma_{co}^2 = \emptyset$
Poisson's Ratio	.0158 (p)*	40	.0193	16	1.23	1.30	Yes 1.23 < 1.30	0.0168	56	Use pooled var. $\sigma_{IIp}^2$ to evaluate curing phase $\sigma_m^2 = \sigma_{co}^2 = \emptyset$
Tensile Strength	439.170 (p)*	40	412.955	16	0.94	1.30	Yes 0.94 < 1.30	431.680	56	Use pooled var. $\sigma_{IIp}^2$ to evaluate curing phase $\sigma_m^2 = \sigma_{co}^2 = \emptyset$
Total Tensile Strain at Failure	$0.1495 \times 10^{-6}$	25	$0.1513 \times 10^{-6}$	16	1.01	1.34	Yes 1.01 < 1.34	0.1502	41	Use pooled var. $\sigma_{IIp}^2$ to evaluate curing phase $\sigma_m^2 = \sigma_{co}^2 = \emptyset$
Estimated Elastic Tensile Strain at Failure	$3.036 \times 10^{-8}$ (p)*	40	$2.053 \times 10^{-8}$	16	0.68	1.30	Yes 0.68 < 1.30	$2.75 \times 10^{-8}$	56	Use pooled var. $\sigma_{IIp}^2$ to evaluate curing phase $\sigma_m^2 = \sigma_{co}^2 = \emptyset$

\* (p) in Col. 2 denotes that estimate of true error variance  $\sigma_e^2$  was pooled with estimated mixing phase error variance to obtain more robust mixing phase error variance estimate.

TABLE 20. EVALUATION OF CURING PHASE

Parameter	Estimated Comp. Phase Error		Estimated Curing Phase Error		Calculated F Value F=Col 4/Col 2	Critical F Value Fcr( $\gamma=.25$ )	Can $\sigma_{II}^2(p)$ and $\sigma_{III}^2$ be pooled (if $F < F_{cr}$ )	Comments Concerning Phasing
	Variance $\sigma_{II}^2(p)^*$	dfII(p)	Variance $\sigma_{III}^2 = \sigma_{II}^2 + \sigma_{co}^2$	dfIII				
Modulus of Elasticity	$0.567 \times 10^{10}$ (p)	56	$0.423 \times 10^{10}$	22	0.75	1.25	Yes 0.75 < 1.25	No Phasing $\sigma_{m_2}^2 = \sigma_{co}^2 = \sigma_{cu}^2 = \emptyset$ $\sigma_e$ can be used as error variance
Poisson's ratio	.0168 (p)	56	.0168	22	1.00	1.25	Yes 1.00 < 1.25	No Phasing $\sigma_{m_2}^2 = \sigma_{co}^2 = \sigma_{cu}^2 = \emptyset$ $\sigma_e$ can be used as error variance
Tensile Strength	431.680 (p)	56	414.539	22	0.96	1.25	Yes 0.96 < 1.25	No Phasing $\sigma_{m_2}^2 = \sigma_{co}^2 = \sigma_{cu}^2 = \emptyset$ $\sigma_e$ can be used as error variance
Total Tensile Strain	$0.1502 \times 10^{-6}$ (p)	41	0.1432	22	0.95	1.27	Yes 0.95 < 1.27	No Phasing $\sigma_{m_2}^2 = \sigma_{co}^2 = \sigma_{cu}^2 = \emptyset$ $\sigma_e$ can't be used as error variance
Estimated Elastic Tensile Strain	$2.755 \times 10^{-8}$	56	$3.923 \times 10^{-8}$	22	1.42	1.25	No 1.42 > 1.25	See discussion

\* (p) in Col. 2 denotes estimate of mixing phase variance  $\sigma_I^2$  was pooled with estimated compaction phase variance  $\sigma_{II}^2$ .

did not equal zero, i.e.,  $\sigma_m^2 \neq 0$  and therefore, existed; or secondly, the estimate of true error variance was a poor substitute for the estimate of experimental error, i.e., there was day-to-day variation in the results.

Since the variances for the three phases, i.e.,  $\sigma_I^2$ ,  $\sigma_{II}^2$ ,  $\sigma_{III}^2$ , are essentially the same, this meant that errors due to compaction and curing variables were not present and that  $\sigma_{co}^2 = \sigma_{cu}^2 = \emptyset$ . In addition, there was no reason to expect errors due to mixing variables to be present if compaction and curing variables did not exist; therefore, the first reason was rejected.

It is more likely that the difference was attributable to a poor estimate of experimental error variance which would indicate the presence of day-to-day variation in the data. The importance of knowing the proper experimental error variance will become more apparent in the analysis of variance and regression analysis section of this report.

In the case of estimated elastic tensile strain, there was apparently no difference between the experimental error variance and the mixing and compaction phase error variances; however, the analysis indicated that the curing phase error variance was different than the pooled estimate of error variance for the compaction. On the other hand, a comparison of the experimental error variance and the curing phase error variance (respectively  $3.433 \times 10^{-8}$  and  $3.923 \times 10^{-8}$ ) would indicate no significant difference. The error variance for the mixing and compaction were smaller than the experimental error variance with the result that during pooling the pooled experimental error was less than the experimental error variance. Because of these circumstances, a subsequent F test was conducted by comparing curing phase error variance with the original experimental error variance. This  $F_a$  ratio is calculated as 1.14 which, when compared with a critical  $F_{cr}$  value of 1.41 (probability level of 25 percent), indicates no significant difference between the two variances. Based on this additional significance test, the conclusion was made that there was no effect due to the three phases on the estimated elastic tensile strain.

#### AN EVALUATION OF EXPERIMENTAL ERROR VARIANCE

An investigation of experimental error variance would require tests to determine if there was a day-to-day effect on the results of the indirect tensile test. That is to say, the results acquired in the same time period

(i.e., hour or day) for identical specimens, would be consistently smaller than results for replicate specimens tested in different time periods.

The analysis to evaluate the difference between estimates of true error variance from duplicate specimens and estimates of experimental error variance from replicate specimens includes 15 pairs of duplicate specimens which were tested on the same day and 64 pairs of replicate specimens; the first one-half of the pairs were tested on a day three weeks prior to the second half.

The results of the analysis are presented in Table 21. Statistical significance tests were used again here to determine with some probability ( $\alpha = 0.25$ ) if there was a difference between the two estimated variances. A pooled estimate of experimental error variance was calculated for those parameters which exhibited no differences between the true error and experimental error variance estimates.

There was no significant difference between estimated true error variance and experimental error variance for the parameters, modulus of elasticity, Poisson's ratio, tensile strength, and estimated elastic strain, which means that there were no day-to-day variations. The tensile strain parameter, on the other hand, exhibited a difference in the two variances indicating the existence of day-to-day variation. This was hypothesized in the previous section.

The pooled variance estimates will be used in further analyses for the first three parameters, as well as the fifth parameter, while the experimental error variance was used for the total tensile strain parameter.

TABLE 21. EVALUATION OF EXPERIMENTAL ERROR

Parameter	True Error Variance estimate	df	Experimental Error Variance estimate	df	F Value Col 5/Col 3	Critical F Value	Can Variances be pooled	Pooled Variance Estimate
Modulus of Elasticity	$0.699 \times 10^{10}$	15	$0.509 \times 10^{10}$	64	0.73	1.27	Yes	$0.539 \times 10^{10}$
Poisson's ratio	.0163	15	.0166	64	1.02	1.27	Yes	.0165
Tensile Strength	405.13	15	471.65	64	1.16	1.27	Yes	459.02
Total Tensile Strain at Failure	$0.105 \times 10^{-6}$	15	$0.164 \times 10^{-6}$	64	1.56	1.27	No	-
Estimated Elastic Tensile Strain at Failure	$3.433 \times 10^{-8}$	15	$2.936 \times 10^{-8}$	64	0.86	1.27	Yes	$3.030 \times 10^{-8}$

## THE AUTHORS

William O. Hadley is a Research Associate with the Center for Highway Research at The University of Texas at Austin. He has had experience in the areas of highway design, power plant construction, and missile complex construction at Cape Kennedy, Florida. He is the author of several technical papers and reports and is currently involved in researching and evaluating the use of asphalt-treated subbases in rigid pavement construction.



W. Ronald Hudson is an Associate Professor of Civil Engineering and Associate Dean of the College of Engineering at The University of Texas at Austin. He has had a wide variety of experience as a research engineer with the Texas Highway Department and the Center for Highway Research at The University of Texas at Austin and was Assistant Chief of the Rigid Pavement Research Branch of the AASHO Road Test. He is the author of numerous publications and was the recipient of the 1967 ASCE J. James R. Croes Medal. He is presently concerned with research in the areas of (1) analysis and design of pavement management systems, (2) measurement of pavement roughness performance, (3) slab analysis and design, and (4) tensile strength of stabilized subbase materials.



Thomas W. Kennedy is an Associate Professor of Civil Engineering at The University of Texas at Austin. His experience includes work with the Illinois Division of Highways and research at the University of Illinois and the Center for Highway Research at The University of Texas at Austin, where he has conducted extensive investigations in the areas of (1) highway geometrics, (2) concrete durability, (3) tensile strength of stabilized subbase materials, and (4) time-dependent deformation of concrete and has contributed numerous publications in the field of transportation engineering. He is a member of several professional societies and has participated in committee work for the Highway Research Board and the American Concrete Institute.

