

73-8521-250  
5/11

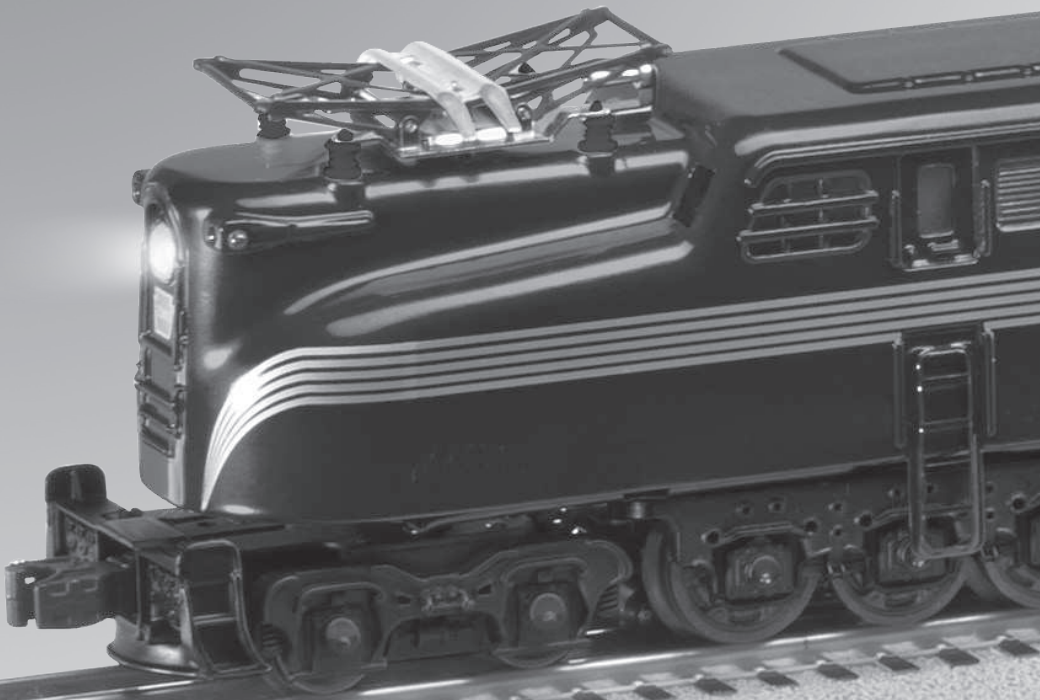

***Lionel  
GG-1 Locomotive  
Owner's Manual***

# ***Congratulations!***

**C**ongratulations on the purchase of your Lionel GG-1 Locomotive, originally used by the Pennsylvania Railroad. This GG-1 locomotive is powered by two maintenance-free motors, which enable it to pull a long line of cars.

## **Locomotive Features**

---

- **Transformer controller forward, neutral and reverse operation**
- **Conventional RailSounds sound system**
- **Dual operating couplers**
- **Dual powerful maintenance-free motors**
- **Operating pantographs which raise and lower manually**
- **Magne-Traction track gripping system**
- **Traction tires**
- **Operating headlights**
- **Illuminated marker lights**
- **Minimum Curve: 0-31**

*The following Lionel marks are used throughout this catalog and are protected under law. All rights reserved.*

*Lionel®*, *LEGACY™*, *FasTrack™*, *TrainMaster®*, *Odyssey®*, *RailSounds®*, *CrewTalk™*, *TowerCom™*, *DynaChuff™*, *StationSounds™*, *Pullmor®*, *ElectroCoupler™*, *Magne-Traction®*, *CAB-1® Remote Controller*, *American Flyer®*, *Lionel ZW®*, *ZW®*, *MagniVision®*, *TMCC®*, *Lionelville®*, *Wireless Tether™*, *Powerhouse™*, *LionMaster®*, *Conventional Classics™*, *Postwar Celebration Series™*, *TruRail™*, *PH-1 Powerhouse®*, *Powermaster®*, *Powerstation-Powerhouse®*, *Accessory Motor Controller™*, *AMC™*, *Accessory Switch Controller™*, *ASC™*, *Action Recorder Controller™*, *ARC™*, *Track Power Controller 300™*, *TPC 300™*, *Track Power Controller 400™*, *TPC 400™*, *Block Power Controller™*, *BPC™*, *Operating Track Controller™*, *OTC™*, *FatBoy™*, *Lionel Lines®*, *Joshua Lionel Cowen Series™*, *Lockon®*, *TrainSounds™*, *MultiHorn™*, *MultiWhistle™*, *Choo-Choo™*

# ***Table of contents***

## ***Running your locomotive***

Running your locomotive	4
Locking your locomotive into forward-only operation	5
Installing the pantographs on your GG-1	6
Using your locomotive's magnetic couplers	7

## ***Conventional RailSounds operations***

Operating the conventional RailSounds sound system	8
Sounding your locomotive's horn and bell	9

## ***Maintaining and servicing your locomotive***

Lubricating your locomotive	10
Replacing your locomotive's lamps	11
Replacing your traction tires	11
Lionel Limited Warranty Policy & Service	12

# ***Running your locomotive***

## **Running your locomotive**

---

**Caution!** Do not power your locomotive with direct current (DC). Damage to sensitive electronic components may occur.

**1**

**With track power off, place your locomotive on Lionel or Lionel-compatible O-gauge track.**

**2**

**Throttle up the locomotive with your transformer.**

Your locomotive is designed to operate on 8-18 volts alternating current. Virtually all Lionel and Lionel-compatible alternating current transformers are suitable.

**3**

**Get your locomotive moving.** Your locomotive goes through a repeating pattern of operations: forward, neutral, reverse, neutral, and so on. To sequence the reverse unit, press the DIRECTION button on your transformer, or briefly bring the throttle all the way back to the OFF position and then forward, for one to four seconds. When track power is interrupted, the locomotive advances to the next operational state.

Adjust track voltage until your locomotive moves at your desired speed.

# Running your locomotive

## Locking your locomotive into forward-only operation

**W**hen the electronic reverse unit switch is in the RUN position, your locomotive sequences through a repeating pattern of operations: forward, neutral, reverse, neutral, and so on.

To “lock” your locomotive into forward operation only, you can deactivate the reverse unit’s sequencing function. Follow the steps below and refer to Figure 1 for the location of the reverse unit switch.

1. Turn off track power, wait three seconds, and then remove the locomotive from the track.
2. Slide the reverse unit switch to the LOCK position. See Figure 1 for the location of this switch. At this point, the locomotive is “locked” into forward direction operation.
3. Place your locomotive back on the track. Power up the track and press the DIRECTION button on your transformer to confirm that the locomotive is locked in forward-only operation.

To restore the forward-neutral-reverse sequence, turn off track power and remove your locomotive from the track. Slide the reverse unit switch back to the RUN position, then place the locomotive back on the track.

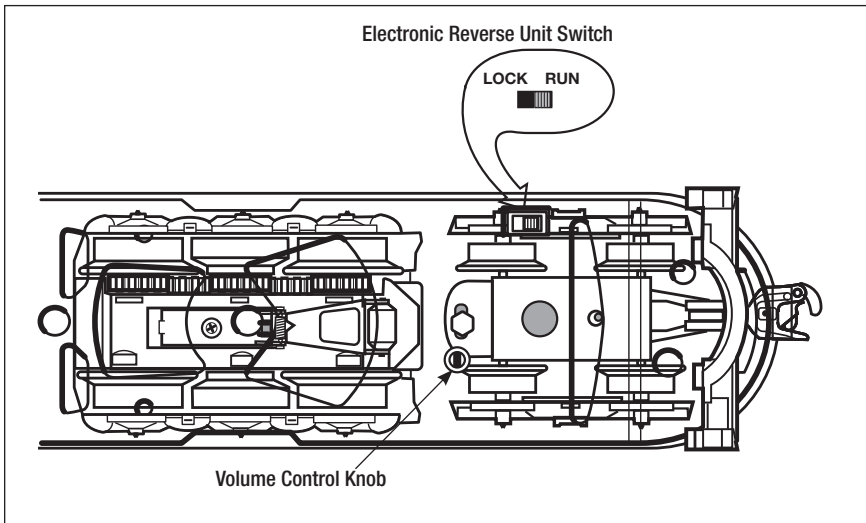

Figure 1. Switch and volume control locations

# Running your locomotive

## Installing the pantographs on your GG-1

**A**lthough your locomotive is wired to operate on a three-rail track, it is equipped with operating pantographs which can be wired into the power circuit by any model railroader whose layout works with a catenary, or overhead power line.

The pantographs are held in place with a spring catch and can be removed simply by pulling the base frame upward. This is a very important feature as it prevents damage to the pantograph in the event of a derailment or catching on a catenary. To replace, open the pantograph and snap into place by pushing in the center portion. See Figure 2 below.

### Catenary Operation

For prototypical operation with the pantographs, remove the body screws from the underside of the locomotive and lift the body from the frame. See Figure 4 on page 10 for the location of the body screws. An adult should cut and splice a wire from one of the collector leads to the rear pantograph. The pantograph in the rear should be raised to collect power.

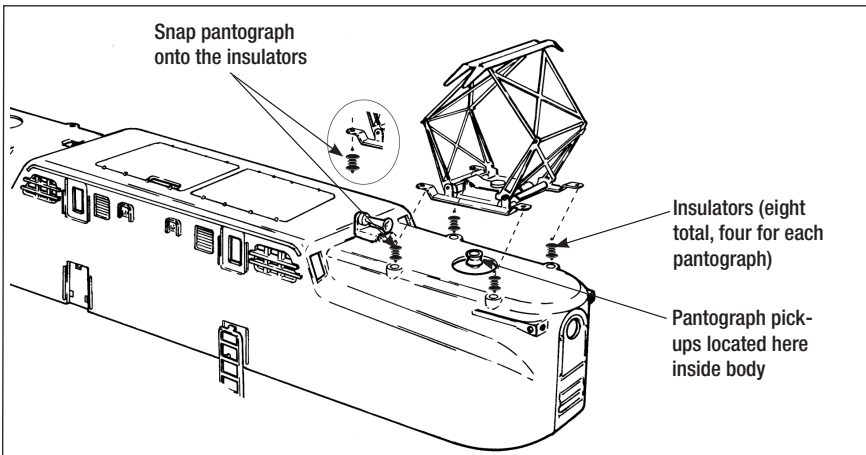

Figure 2. Installing the pantographs

**Note!** Operation with raised pantographs will require increased overhead clearance.

# Running your locomotive

## Using your locomotive's magnetic couplers

---

**Y**our Lionel locomotive is equipped with operating magnetic knuckle couplers. Magnetic couplers react to the magnetic field generated by a Lionel Remote-Control Track section (available separately, 6-65149 or 6-12746 for O-27 gauge; 6-65530 for O gauge; or 6-12020 and 6-12054 for FasTrack layouts).

As illustrated in Figure 3, place your locomotive's coupler trigger disc over the central coil of a Remote-Control Track section and press UNCOUPLE on the controller. The magnetic field pulls the disc downward, and the knuckle opens.

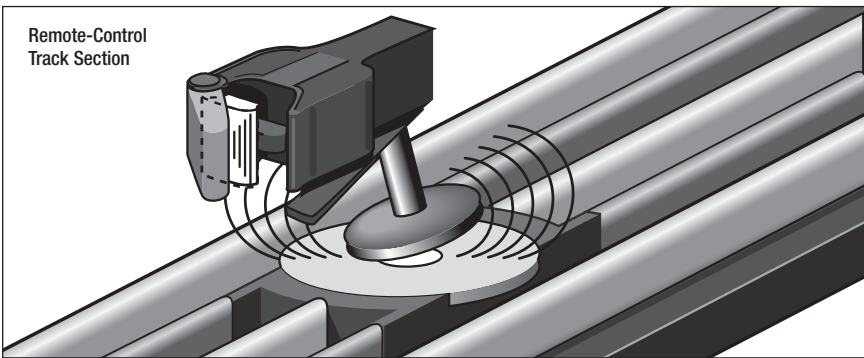

Figure 3. Magnetic coupler operation

# ***Conventional RailSounds operations***

## **Operating the conventional RailSounds sound system**

---

**W**hen you power up the locomotive on the track, you will hear the sounds of the idling locomotive. The sounds will increase proportionally with the locomotive's speed. Use the volume control knob to adjust the volume. See Figure 1 on page 5 for the location of this control, which is located on the underside of the locomotive.

### ***Whistle/Horn***

Press the **WHISTLE/HORN** button on your transformer to sound the whistle/horn. The sound will play for as long as you hold the button.

### ***Bell***

Press the **BELL** button on your transformer to activate the bell sound. Press **BELL** again to discontinue the sound.

### ***Crew dialog***

CrewTalk dialog and TowerCom announcements are triggered by short whistle blasts and depend on whether the locomotive is moving or standing still, as well as the duration.

- If the locomotive has been stopped for less than 15 seconds, a short whistle blast triggers a "please stand by" dialog.
- If the locomotive has been stopped for longer than 15 seconds, a short whistle blast triggers a "clear outbound" announcement.
- If the locomotive is moving, a short whistle blast triggers an "all clear ahead" dialog.
- If the locomotive is moving and the bell is on, a short whistle blast triggers a "slow to restricted speed" dialog.



# Conventional RailSounds operations

## Sounding your locomotive's electronic horn and bell

Use the **HORN** and **BELL** buttons on your transformer to activate the locomotive's horn and bell sounds. If your transformer lacks **HORN** and **BELL** buttons, you will need to install Lionel no. 6105906001 Sound Activation Buttons (available separately) to activate the locomotive's horn and bell sounds.

Connect the buttons as shown below. Be sure that all track power passes through the Sound Activation Button(s).

### For AC transformers lacking a bell button

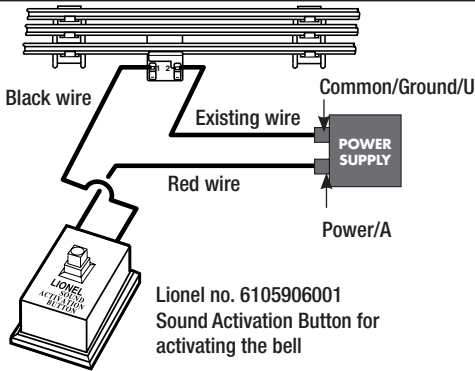

### For AC transformers lacking bell and horn/whistle buttons

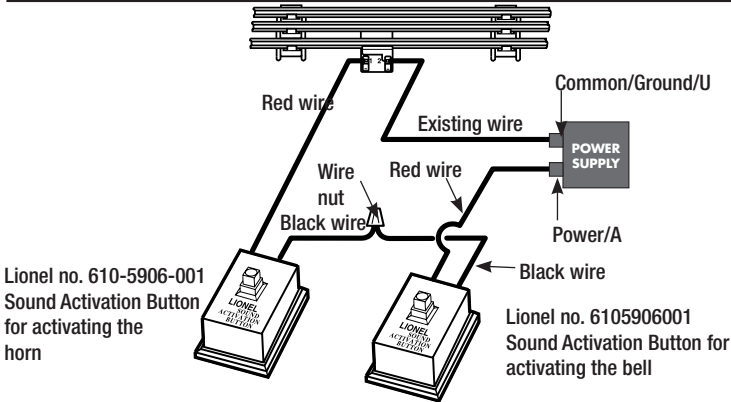

To adjust the volume or to silence the electronic horn and bell sounds, use the volume control knob located on the underside of the locomotive. See Figure 1 on page 5 for the location of the Volume Control Knob.

# Maintaining and servicing your locomotive

## Lubricating your locomotive

**H**elp your Lionel locomotive lead a long and productive life on your railroad by maintaining it properly. To keep your locomotive lubricated, we recommend that you purchase a Lionel Lubrication and Maintenance Kit (6-62927), available from your authorized Lionel dealer or service station.

When you find that the lubrication points illustrated in Figure 4 appear dry, lubricate your locomotive after you have removed any accumulated dirt and dust. There are two basic rules to keep in mind when you are lubricating your locomotive: use only a small amount of lubrication and avoid getting grease or oil on your locomotive's wheels, roller pick-ups, or the track.

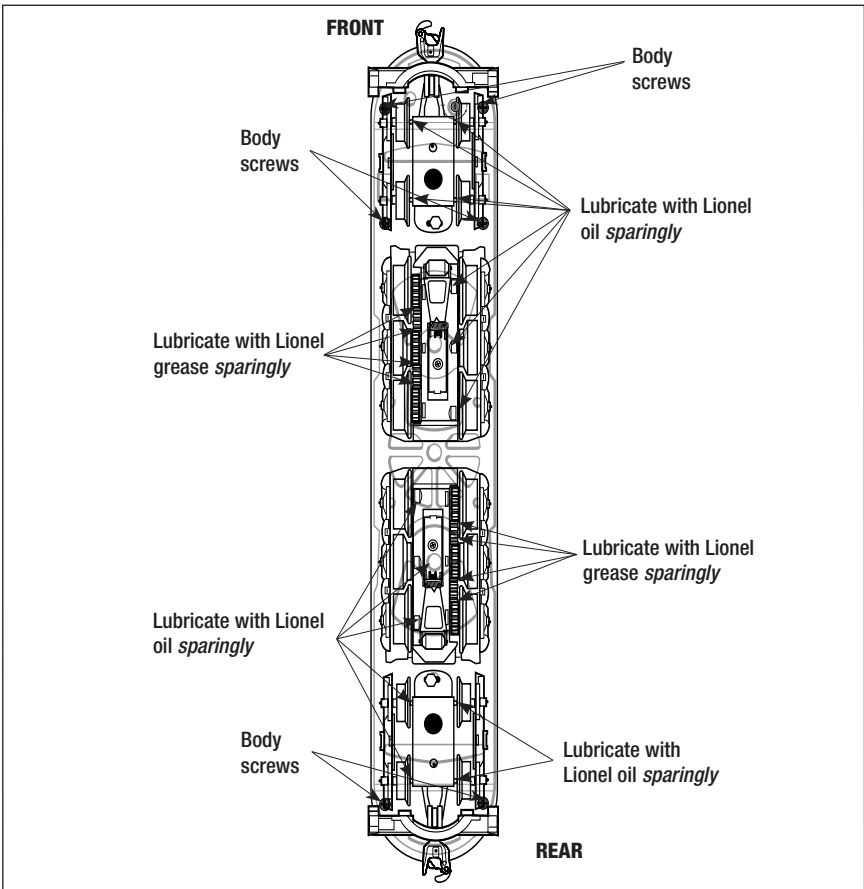

Figure 4. Underside details and lubrication points

# Maintaining and servicing your locomotive

## Replacing your locomotive's lamps

Your locomotive is illuminated by two 14-volt bayonet base lamps. During the course of normal operations, they may require replacement.

1. Remove the locomotive's six body screws. See Figure 4 on page 10 for the screw locations. Carefully lift the shell away from the frame.
2. Locate the assembly containing the expired lamp. To remove the lamp, gently push the lamp down and turn counter-clockwise to disengage the lamp from the socket. See Figure 5.
3. Replace it with Lionel part no. 6000363300, available from your Factory Trained Lionel Service Station, or from Lionel Customer Service. See **Instructions for Obtaining Service** on the back cover for more information.
4. Replace the body, securing it with the six body screws.

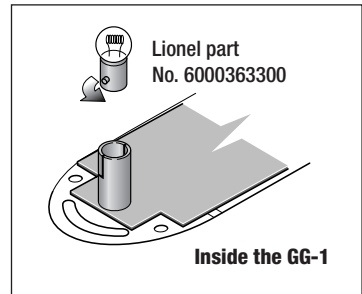

Figure 5. Lamp replacement

**Note!** To prevent damage to the locomotive body, do not overtighten the body screws.

## Replacing the traction tires

Your locomotive is equipped with traction tires to increase the tractive effort of your locomotive and allow it to pull more cars at one time.

During the course of normal operations, the traction tires may become worn out. Replacement traction tires are included with the locomotive. We recommend that you have the traction tires (6308302065) replaced by an authorized Lionel dealer or service station because the truck and side frames must be removed to access the wheels. See **Instructions for Obtaining Service** on page 12 for more information.

# Lionel Limited Warranty Policy & Service

---

This Lionel product, including all mechanical and electrical components, moving parts, motors and structural components, with the exception of **LIGHT BULBS, LED's & TRACTION TIRES** are warranted to the original owner-purchaser for a period of **one year from the original date of purchase** against original defects in materials or workmanship when purchased through a **Lionel Authorized Retailer\***.

This warranty does **NOT** cover the following:

- Normal wear and tear
- Light bulbs or LED's
- Defects appearing in the course of commercial use
- Damage resulting from abuse/misuse of the product

Transfer of this product by the original owner-purchaser to another person voids this warranty in its entirety. Modification of this product in any way; visually mechanically or electronically, voids the warranty in its entirety.

Any warranted product which is defective in original materials or workmanship and is delivered by the **original owner-purchaser** (this warranty is non-transferrable) to Lionel LLC or any Lionel Authorized Service Station **MUST** be accompanied by the original receipt for purchase (or copy) from an **Authorized Lionel Retailer\***, will at the discretion of Lionel LLC, be repaired or replaced, without charge for parts or labor. In the event the defective product cannot be repaired, and a suitable replacement is not available, Lionel will offer to replace the product with a comparable model (**determined by Lionel LLC**), if available. In the event a comparable model is not available the customer will be refunded the original purchase price (requires proof of purchase from the **Authorized Lionel Retailer\*** it was originally purchased). Any products on which warranty service is sought must be sent freight or postage prepaid (Lionel will refuse any package when postage is due). **Transportation and shipping charges are not covered as part of this warranty.**

**NOTE: Products that require service that do not have a receipt from an LIONEL AUTHORIZED RETAILER\* will be required to pay for all parts required to repair the product (labor will not incur a charge) providing the product is not older than 3 years from date of manufacture and is within 1 year from date of purchase. A copy of the original sales receipt is required.**

**In no event shall Lionel LLC be held liable for incidental or consequential damages.**

---

Some states do not allow the exclusion or limitation of incidental or consequential damages, so the above exclusion may not apply to you. This warranty gives you specific legal rights and you may have other rights which vary from state to state.

## Instructions for Obtaining Service

---

If service for this Lionel LLC product is required; bring the item, along with your DATED sales receipt and completed warranty information (at the bottom of this page) to the nearest Lionel Authorized Service Station. Your nearest Lionel Service Station can be found by calling 1-800-4-LIONEL or by accessing the website at [www.lionel.com](http://www.lionel.com).

If you prefer to send your Lionel product directly to Lionel, for repair you must FIRST call 586-949-4100 extension 9105 or FAX Lionel at 586-949-5429 or write to Customer Service, 26750 Twenty Three Mile Road, Chesterfield, MI 48051-2493. Please have the 6-digit Lionel product number, the date of original purchase, the dealer where the item was purchased and what seems to be the problem. You will receive a return authorization (RA) number to ensure your merchandise will be properly tracked and handled upon receipt at Lionel LLC.

Once you have your Return Authorization (RA) number, make sure the item is packed in its original Styrofoam inner container which is placed inside the original outer display box (this will help prevent damage during shipping and handling). This shipment **MUST** be prepaid and we recommend that it be insured with the carrier of your choice.

Please make sure you have followed all of the above instructions carefully before returning any merchandise for service. You may choose to have your product repaired by one of Lionel LLC's Authorized Service Stations after its warranty has expired. A reasonable service fee should be expected once the product warranty has expired.

## Warranty Information

---

Please complete the information below and keep it, along with your **DATED ORIGINAL SALES RECEIPT**. You **MUST** present this form **AND** your **DATED SALES RECEIPT** when requesting warranty service.

\*A complete listing of Lionel Authorized retailers can be found by calling 1-800-4-LIONEL or by visiting our website at [www.lionel.com](http://www.lionel.com).

Products that are more than 3 years old, from date of manufacture, are not applicable for warranty coverage, even if they have never been sold prior to this date. (Under no circumstance shall any components or labor be provided free of charge.)

Name \_\_\_\_\_  
Address \_\_\_\_\_  
Place of Purchase \_\_\_\_\_  
Date of Purchase \_\_\_\_\_  
Product Number \_\_\_\_\_  
Product Description \_\_\_\_\_

