

Location:



MI-SADH

HIGH SECURITY ACCESS DOOR

Specification: MIFAB Series MI-SADH high security access door is designed to provide security access, with a strength and durability to endure abusive and vandal-prone conditions, common in many institutions. It has a unique white finish.



Material: MI-SADH Series is 10 gage steel door and 1/4" angle steel frame. The MI-SADHSS

Stainless Steel Series is 10 gage #304 stainless steel door and 1/4" (6) angle stainless steel frame.

Finish: Steel doors have a primed white finish. Stainless steel doors have a #4 brush satin finish.

Door: Flush to frame.

Frame: 1/4" x 2" x 2" (6 x 50 x 50) angle steel, angle welded with joints ground smooth. The frame has pre-punched 1/4" (6) mounting holes for easy installation.

Hinge: Two heavy duty butt hinges welded to the door and frame.

Latch: Standard - Best Lock #1E7D4-C228-RP3-626 with key. Optional - locks provided by others.

Packaging: Individual pack.

"B" x "A"	WALL OPENING	SHIP WEIGHT (Lbs.)	LATCHES	MILD STEEL MODEL #	STAINLESS STEEL MODEL #
12" x 12"	12-1/2" x 12-1/2"	22.0	1	MI-SADH1212	MI-SADHSS1212
16" x 16"	16-1/2" x 16-1/2"	31.0	1	MI-SADH1616	MI-SADHSS1616
18" x 18"	18-1/2" x 18-1/2"	37.0	1	MI-SADH1818	MI-SADHSS1818
24" x 24"	24-1/2" x 24-1/2"	55.0	1	MI-SADH2424	MI-SADHSS2424
24" x 36"	24-1/2" x 36-1/2"	73.0	2	MI-SADH2436	MI-SADHSS2436
24" x 48"	24-1/2" x 48-1/2"	88.0	2	MI-SADH2448	MI-SADHSS2448
36" x 36"	36-1/2" x 36-1/2"	97.0	2	MI-SADH3636	MI-SADHSS3636
36" x 48"	36-1/2" x 48-1/2"	120.0	2	MI-SADH3648	MI-SADHSS3648

SUFFIX OPTIONAL VARIATIONS

- BA Buy American Act compliant product
- PA Pennsylvania Steel Act compliant product

A-B Door Size

C-D Overall Dimensions - Door Size - Plus 4" (102)

E-F Wall Opening - Door Size - Plus 1/2" (13)

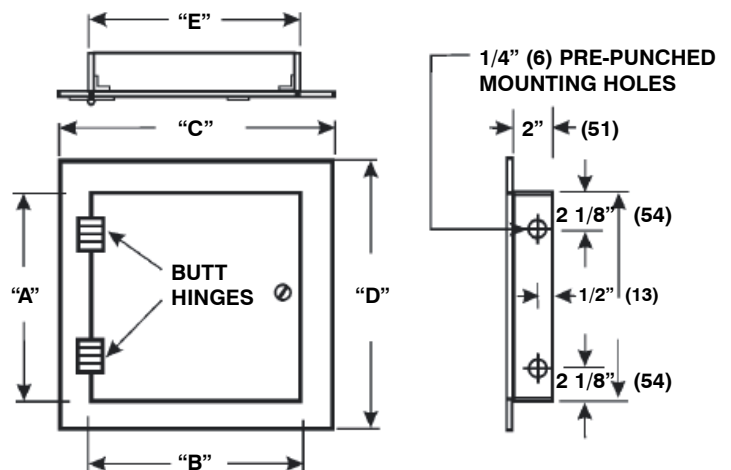

(Dimension) Denotes Millimetres

Note: The hinge is always furnished on the "A" or height (longer) dimension, unless otherwise specified.

Job Name: <input type="text"/>	Page No: <input type="text"/>
Section No: <input type="text"/>	Contract: <input type="text"/>
Schedule No: <input type="text"/>	Purchase Order No: <input type="text"/>