



Order of the Arrow

2012 NOAC Museum

NOAC Theme: *“UNITED, WE LEAVE A LEGACY.”*

Lodge Display Application Form

Please complete the following to submit an application for an exhibit/display:

DEADLINE: MAY 1ST

See page 2 for additional details. Submit completed form on-line or to: NOACMuseum@gmail.com

Lodge Name:

Council Name: Council #:

Contact Person: Phone (primary/cell):

eMail:

Address:

Street Address

City

State

Zip Code

Title/Content -
Items displayed:

Physical Description:
(more detail is better!
use additional page if
necessary)

Note: Attach or send pictures or a sketch of display if available.

Display table needed (Yes/No): Linear feet desired: Height & depth

Comments/Special
Considerations/Needs:
(i.e.: electrical, lighting, etc.)

By submitting this application, approval is given to take and use digital images of said display as part of the OA historical preservation project.

If you have any questions about your exhibit or in filling out this form, please send to: NOACMuseum@gmail.com

See the following for some sample ideas for a Lodge display layout:

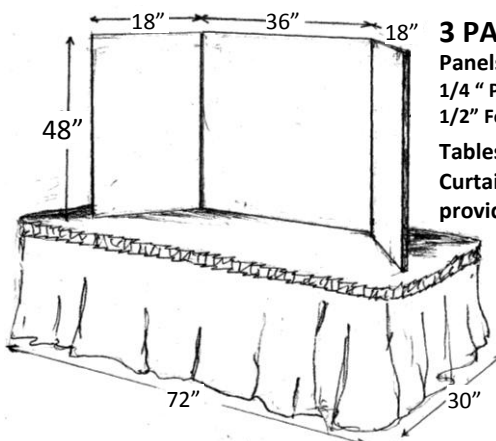

3 PANEL
Panels should be:
1/4 " Plywood or
1/2" Foam Core
Tables (72" x 30") &
Curtains will be
provided

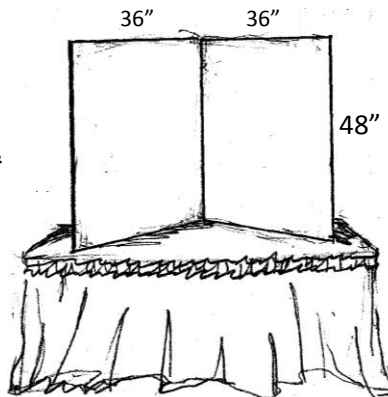

2 PANEL

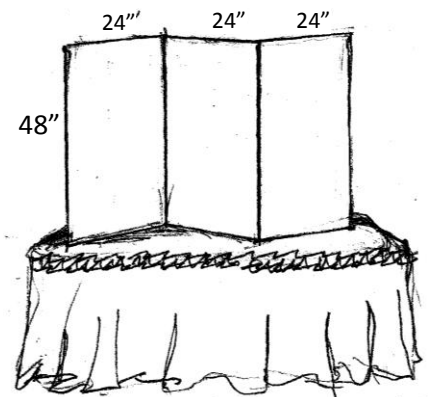

Additional
Suggestions

3 PANEL



IMPORTANT INFORMATION REGARDING YOUR LODGE DISPLAY

2012 NOAC Museum - Lodge Display Application Form

CONSTRUCTION:

DEADLINE TO SUBMIT FORM: MAY 1ST

This conference we are asking lodges to create a “traveling display.” That means that the display should be easy to transport, not only to the NOAC, but to lodge and section events afterward. **DO NOT USE VALUABLES.** Rather, consider using a simple quality image of a rare item. It not only looks almost the same as the actual item, but it also eliminates risk involved in transport and display. No additional credit will be given for using valuable items over images of the same rare items. Remember, if this is a traveling display, you want to be able to set this up at an event and not worry about security.

THEME:

When developing your display, it is important to incorporate the conference theme; “***UNITED, WE LEAVE A LEGACY.***” When considering what to include in your lodge’s display, think about how your display will demonstrate both elements of the theme “Unity” and “Legacy.” How has your lodge and your lodge’s members worked together? What is/was the legacy created by your lodge? Is there a specific project or event that the lodge has participated in that highlights the theme? The possibilities are endless, so be creative.

CONFERENCE LOGISTICS:

Lodges will be able to drop off their exhibits on Monday, July 30, 2012 at the OA Center for History. Exhibits should be freestanding and able to remain on display until Friday, August 3, 2012. Judging will be conducted on Tuesday, July 31, 2012.

JUDGING CRITERIA:

Lodge historical displays should be a learning experience for those viewing it and should demonstrate originality and creativity. A combination of memorabilia including patches or images of patches, lodge histories, pictures, drawings, descriptions and other memorabilia is expected. As noted above, no additional credit will be given for using valuable items over images of the same rare items. *Youth participation is highly recommended and will improve overall judging score.*

Scoring is based on the following:

1. Professional Value and Originality: Provides information of interest and value to museum attendees. Presents information in an innovative style. The display reflects the conference theme and crafts a unique story.
2. Visual Impact: First impression of the display, neatness, layout, overall impact to the viewer. Display is eye-catching, attractive, interesting and easy to read.
3. Educational Value: Offers viewers a learning experience. Display teaches the viewer the history of the lodge. Descriptions are attached to the display that tells the viewer about the items being presented. The display is easy to follow and understand.
4. Historical Significance: Historical significance to the preservation of our Scouting heritage. Tasteful use of memorabilia and chronicles events and figures associated with the lodge's history is expected. Degree of difficulty of collecting the items for display, dates of issue, number of items issued, etc.
5. Youth Participation: *Youth participation is highly recommended and will improve overall judging score.* Exhibitors are encouraged to place a statement to this effect on the front or back of the display. Pictures with exhibitor's name(s), lodge name and whether youth and/or adult is encouraged.