

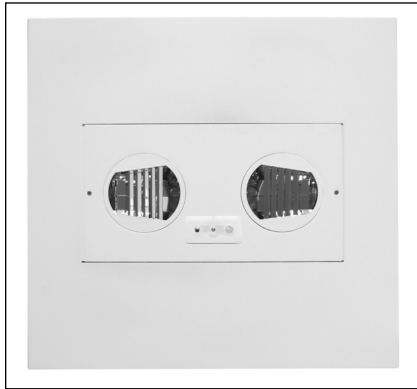

Type No. _____

Job Name _____

Catalog No. _____



Shown: I2WSC



Illusion²

Specially Designed for Suspended Ceiling Installations

12 Volt, 72 Watt Units

Sealed Lead Calcium Battery

Excellent Photometric Performance

Housing

- Backbox constructed of 14 gauge galvanized steel
- Available with choice of white or black housing colors
- 2' x 2' faceplate constructed of 1/8" thick aluminum for strength and allows direct ceiling tile replacement
- Use structural support wire or bar hanger kit (available separately, see "ACCESSORIES") to complete installation
- For suspended ceiling installation only, use I1 Illusion unit for sheetrock ceiling or wall mount installations

Battery

- Maintenance free, sealed lead calcium battery has an expected service life of 5 years with an operating range of 65°F (19°C) to 85°F (30°C)*
- Battery supplies 90 minutes of emergency power
- * Increases or decreases in temperature will affect battery performance capacity. Optimum battery performance realized at 77°F (25°C).

Illumination

- Illumination is provided by two high performance 35 W MR16 lamps combined with a reflector system
- Optical assemblies can be rotated from 0° to 90° for corner installations
- Generates an average of 1 footcandle of emergency illumination over a 6' x 90' path of egress when mounted 10' AFF
- Lamps remain hidden during emergency illumination
- IES photometric files are available upon request

Warranty

- Electronics: 3 years
- Battery: 1 year full, 4 years pro-rata

Electrical Specifications

- 0.27 A (120 VAC)
- 0.13 A (277 VAC)

Smart Charger Electronics

- 120/277 VAC dual voltage input with surge protection
- Charging system is microprocessor driven with software embedded diagnostic routine and precision temperature compensation. See specification sheet L2368 for technical specifications for the electronics. Surge protection, brownout, AC lockout, and low voltage disconnect features are standard.

Smart Charger Self-Testing Diagnostics (optional)

- The Smart Charger diagnostic/charging platform with self-testing mode automatically runs a one-minute self-test every 30 days and a 30-minute test on the sixth and twelfth month. A one-minute or 90-minute test may be initiated via the push to test switch on the unit or by activating the appropriate test command on the optional IR test device.

Code Compliance

- UL 924 listed for suspended ceiling systems
- IC rated for insulated suspended ceilings
- NFPA 101, NEC, BOCA, OSHA and IBC illumination standard

Application

- Corridors
- Open Plan Office Areas
- School Hallways, Lunch Rooms
- Hotel, Retail and General Commercial Construction
- Illusion² meets the Buy American requirements

Ordering Information

I2		SC		ACCESSORIES (Ordered Separately)	
SERIES	HOUSING COLOR	MODEL DESIGNATOR	FACTORY INSTALLED OPTIONS		
I2 = Illusion 2 x 2 Emergency Unit	W = White B = Black	SC = Smart Charger Diagnostics	EX = Special Input Transformer ¹ (must specify voltage & frequency) T = Self-Testing Diagnostics (non-audible) TA = Audible Self-Testing Diagnostics TD = Time Delay ² TP = Tamperproof	I2BHK = Bar Hanger Kit for Mechanical Ceilings T15TP TOOL = Tamperproof Screwdriver RPLTSW = Remote Test Switch Kit for Single Gang Wall Box SCIR = Smart Charger Infra-Red Remote	
Notes: 1) Some options impact UL listing. Consult factory for specifics. 2) 15 minute time delay					

Optics

Recessed Ceiling Mount, 10' AFF

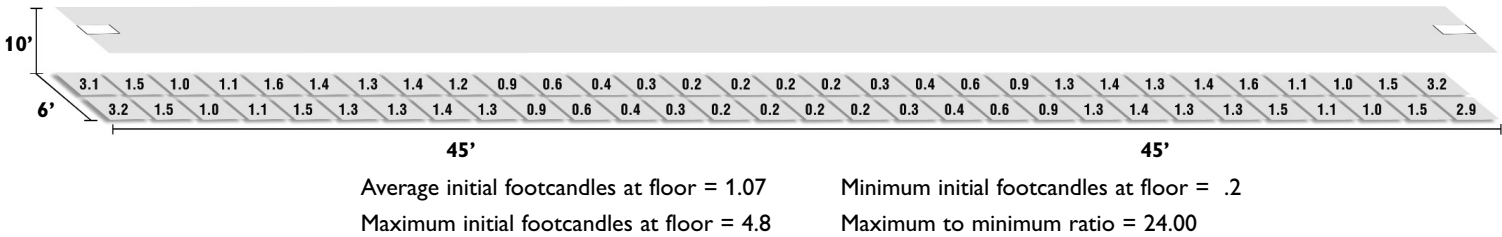

Recessed ceiling mount performance was performed in an open environment. Wall reflectance will increase performance.

IES-formatted photometric data files are available for use with most lighting layout application software. Contact LightGuard technical service for specific layout assistance.

Dimensions

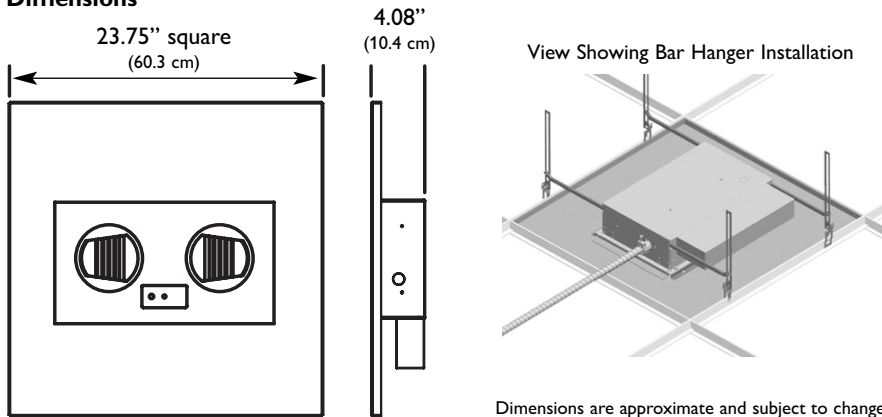

Suggested Specification

Furnish and install LightGuard's concealed emergency lighting model _____. The unit shall be constructed to meet Underwriter's Laboratories, Inc. Standard #924, be IC rated, and must be installed to conform to Article 700 of the National Electrical Code (NEC).

INSTALLATION AND OPERATION - Unit shall be easily field connected to a 120 or 277 VAC, 60 Hz, unswitched power source. Installation must comply with the NEC as well as other applicable codes. Upon utility power failure or brownout, the unit shall automatically provide emergency battery power and maintain the illumination level and output wattage for a minimum period of 90 minutes, in accordance with the requirements of the NFPA 101. Upon restoration of utility power, the charging circuitry shall restore the battery to full charge within UL 924 requirements following a rated discharge of not more than 90 minutes. The unit shall not have any moving mechanisms during emergency operation ensuring reliable operation.

ELECTRONICS - All models shall be provided with LightGuard's Smart Charger self-diagnostics electronics platform. Smart Charger will detect and notify the installer regarding incorrect wiring of the transformer primary and restrict the damaging effects from affecting the printed circuit board. The Smart Charger electronics package shall provide continuous, real-time monitoring of all the critical equipment functions including, but not limited to: line voltage status and condition, charger fault, transfer fault, battery fault, and lamp load fault and notify personnel with a visual indicator sequence. Optional audible diagnostics shall be available from the factory. The optional self-testing software shall satisfy the periodic testing requirements in NFPA 101, Life Safety Code, as well as the International Building Code (IBC). The Smart Charger diagnostic/charging platform with self-testing mode automatically runs a one-minute self-test every 30 days and a 30-minute test on the sixth and twelfth month. The Smart Charger shall continuously sample ambient temperature conditions and adjust the charging regime to compensate for typical and dramatic ambient conditions equal to 3mV/°C compensation to maximize the life of the battery. An on-board IR receiver shall be standard and pre-programmed to operate from an optional IR user interface device (available as an accessory item).

BATTERY - The battery shall be maintenance free, sealed lead calcium. The sealed lead calcium battery shall provide trouble-free operation in temperatures up to 85°F (30°C) and is supplied with a one year full warranty.

ILLUMINATION - Illumination shall be provided by a fully recessed optical system utilizing 35 W MR16 halogen lamps. The unit shall provide an average of 1 footcandle of emergency lighting over a 6' x 90' egress path, when mounted 10' AFF.

HOUSING - Housing construction shall be of 14 gauge galvanized steel and 1/8" aluminum. Unit shall be available in white or black powder coat finish. Unit shall have provisions for bar hangers and/or structural cable supports. All electrical components shall be modular, and should be easily removed for service from front of unit without removal of product from ceiling.

ALL SPECIFICATIONS SUBJECT TO CHANGE WITHOUT NOTICE



272 West Stag Park Service Road • Burgaw, NC 28425
(910) 259-1131 • FAX (800) 403-6927
www.lightguard.com

L2316R10
1/12 IH