

# TruGroove

Linear Recessed - Continuous

Direct Symmetric - Drywall Trimless

I T5



Project Name

Spec Type

Notes

## Order Guide

For run lengths < 8ft. please consult the Standalone Specification Sheets.

39CI	F	I0	Q	S	3	ft.	in.			
Product Type & Size 39CI TruGroove Continuous Symmetric	Light Source F T5	Lamps I0 1 Lamp	Optics Q Flush MesoOptics Lens	Housing S Standard	Ceiling/Trim 3 Drywall Trimless	Run Length Specify length in feet and inches.  Consult factory to specify 1/8" increments.	Wiring 1 1 cct 2 2 cct 3 1 cct w/emergency 5 1 cct w/battery pack 7 1 cct dimming  Consult website for complete list of standard wiring options	Voltage 1 120V 2 277V 3 347V	Ballast E Program Start F Fusing	

## Options

Philips Ledalite will use a combination of 2', 3', and 4' lamps to achieve the exact/on-grid run length specified. Please check the following if 2' and 3' lamps are not preferred in the run.

4' LAMPS ONLY - Closest run length using 4' lamps only (no 2' & 3' lamps)

Please check the following if you would like your lamps supplied.

Lamps Supplied (not installed)

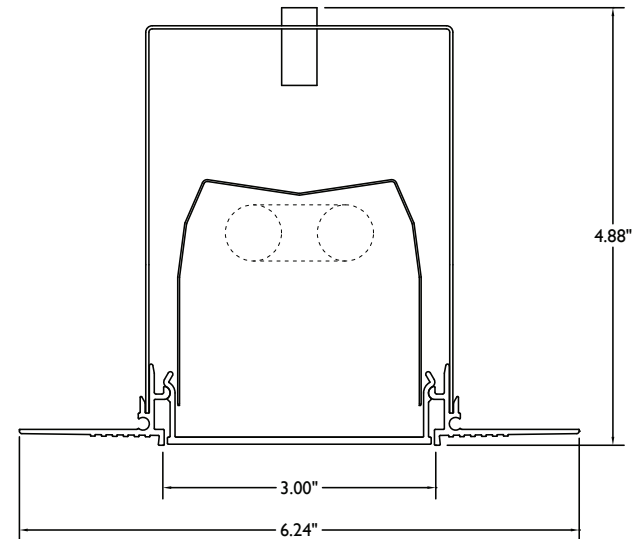

Note: Some combinations of product options may not be available.



## Photometry Flush MesoOptics Lens

### Report Summary

**Efficiency** 82.7%  
**Efficacy** 70.9 lm/W  
**Total Lumens** 2149 lm

**Report No.** 9902690  
**Ballast Factor** 1

**Filename** 39SIF10Qxx04  
**Testing Voltage** 120V

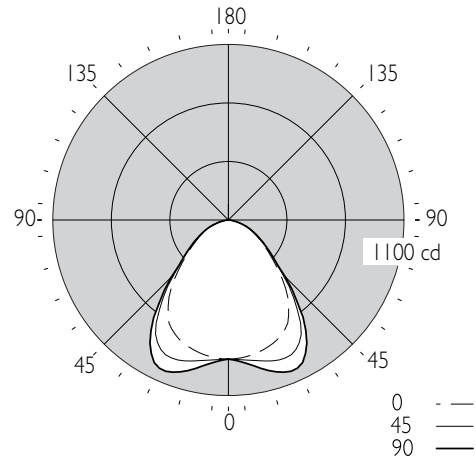

0.0% Up / 100.0% Down

### Candela Distribution

Vertical Angle	Horizontal Angle					Zonal Lumens
	0	22.5	45	67.5	90	
0	872	872	872	872	872	
5	868	870	879	882	891	84
15	842	866	915	950	977	258
25	790	846	932	1002	1024	423
35	658	726	789	860	846	482
45	441	464	481	522	505	378
55	268	283	281	298	286	257
65	161	169	167	176	168	168
75	75	80	75	81	73	83
85	10	13	10	14	11	16
90	0	0	0	0	0	
95	0	0	0	0	0	
105	0	0	0	0	0	
115	0	0	0	0	0	
125	0	0	0	0	0	
135	0	0	0	0	0	
145	0	0	0	0	0	
155	0	0	0	0	0	
165	0	0	0	0	0	
175	0	0	0	0	0	
180	0	0	0	0	0	

### Coefficients of Utilization (%)

RCR	Ceiling: 80				70				50				0
	70	50	30	10	70	50	30	10	50	30	10	0	0
0	98	98	98	98	96	96	96	96	92	92	92	83	
1	91	88	85	82	89	86	83	83	83	80	78	72	
2	84	78	73	69	82	77	72	74	74	70	67	62	
3	78	70	64	59	76	69	63	66	61	58	54	54	
4	72	63	56	51	70	62	56	60	54	50	47	47	
5	66	57	50	45	65	56	49	54	48	44	42	42	
6	62	51	45	40	60	51	44	49	44	39	37	37	
7	57	47	40	36	56	46	40	45	39	35	33	33	
8	54	43	37	32	52	43	36	41	36	32	30	30	
9	50	40	33	29	49	39	33	38	33	29	27	27	
10	47	37	31	26	46	36	30	36	30	26	25	25	

Based on a floor reflectance of 0.2

IES files for this and other photometric options can be downloaded online at [ledalite.com](http://ledalite.com)

### Avg. Luminance (cd/m<sup>2</sup>)

Vertical Angle	Horizontal Angle		
	0	45	90
55	5134	5383	5479
65	4186	4342	4368
75	3184	3184	3099
85	1261	1261	1387

## Dimensions & Details

### DRYWALL TRIMLESS

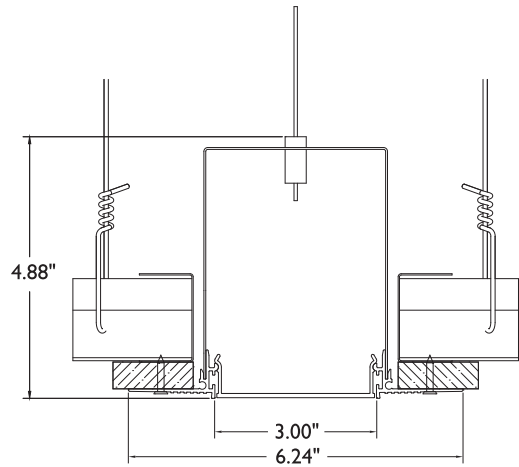

Flush Lens, Trimless

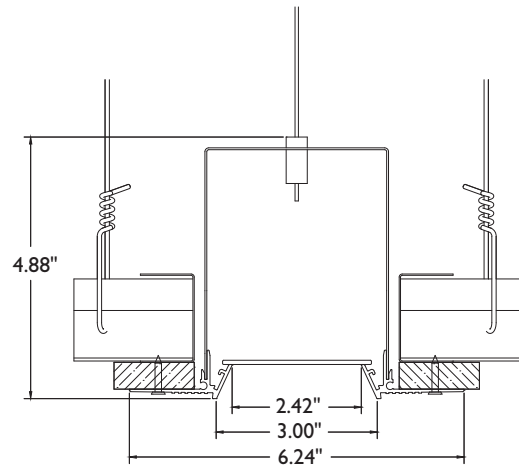

Regressed Lens, Trimless

## Dimensions & Details

### SIDEVIEWS

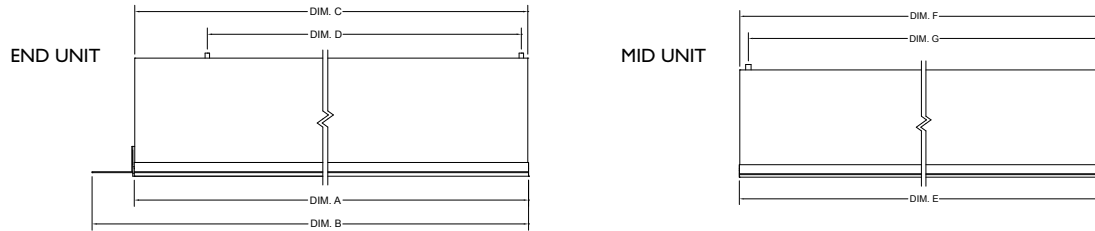

NOTE: When specifying run length, refer to Luminaire Aperture, (DIM. A)

NOMINAL LENGTH	END MODULES				MID MODULES		
	DIM. A LUMINAIRE APERTURE	DIM. B OVERALL TRIM	DIM. C OVERALL HOUSING	DIM. D MOUNTING DIMENSIONS	DIM. E LUMINAIRE APERTURE	DIM. F OVERALL HOUSING	DIM. G MOUNTING DIMENSIONS
3 FT	31.85" / 809mm	33.53" / 852mm	31.81" / 808mm	28.53" / 725mm	29.31" / 745mm	29.28" / 744mm	28.53" / 725mm
4 FT	43.67" / 1109mm	45.34" / 1152mm	43.63" / 1108mm	40.34" / 1025mm	41.13" / 1045mm	41.09" / 1044mm	40.34" / 1025mm
8 FT	84.75" / 2153mm	86.43" / 2195mm	84.71" / 2152mm	81.43" / 2068mm	82.21" / 2088mm	82.17" / 2087mm	81.43" / 2068mm

### CONTINUOUS RUN LENGTHS

All continuous run lengths are made up of a number of mid-units and two end units, with two mounting points on each unit. Layout drawings will be provided for all continuous run orders.

#### Optimum Overlap Design

Lamps are spaced with 4" to 6" overlap to ensure consistent uniformity and eliminate socket shadows.

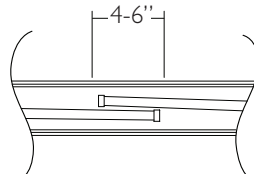

### MesoOptics LENS OPTIONS

Two lens options are available with most TruGroove configurations— a Flush or a Regressed MesoOptics acrylic lens. In continuous run lengths, lenses are pre-cut to maximum 8ft. increments.

#### Flush MesoOptics Lens

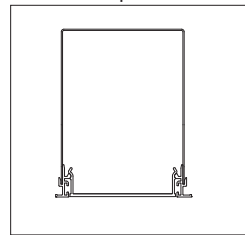

#### Regressed MesoOptics Lens

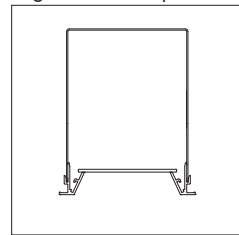

Not available in asymmetric configurations

## Specifications

Due to continuing product improvements, Philips Ledalite reserves the right to change specifications without notice.

### Housing

Die-formed 20 gauge cold rolled steel with aluminum trim. Multiple wire entrances are available on top to allow continuous row mounting of fixtures.

### Optical System

The optical lens assembly consists of multiple acrylic extrusion profiles holding a layer of MesoOptics which efficiently controls high angle glare. The reflector system comprises Miro Silver reflectors optimized to work with MesoOptics to simultaneously homogenize light while creating a batwing distribution in the lower hemisphere.

### Weight

Maximum 3.5lb/ft

### Mounting

Mounting brackets on side of housing supports t-bar installation. 1/16" diameter aircraft cable with self-locking, tamper-resistant, miniature cable gripper provides vertical adjustment for drywall. Aircraft cable, crimp and cable gripper independently tested to meet stringent safety requirements.

### Electrical

Factory pre-wired to section ends with quick-wire connectors.

### Ballast

Electronic. Supplied with factory pre-installed ballast disconnects as per electrical codes.

### Approvals

Certified to UL, IES & CSA Standards.

### Finish

Extruded aluminum trim and die-cast endplates coated with electrostatically applied and thermally cured polyester powder coat paint finish. Other custom colors are available; consult factory for details.

### Environment

Rated for dry or damp locations in operating ambient temperatures of 0-40°C (32-104°F).

