

Reverse Osmosis User's Manual

Models

Titan 10000, Titan 15000, Titan 20000



Introduction

Your Titan reverse osmosis system is a durable piece of equipment which, with proper care, will last for many years. This User's Manual outlines installation, operating, maintenance, and troubleshooting details vital to the sustained performance of your system.

The test results which are included with this User's Manual indicate your system's permeate (product) and rejection test results.

If your system is altered at the site of operation or if the feed water conditions change, please contact your local dealer or distributor to determine the proper recovery for your application. **NOTE: IN ORDER TO MAINTAIN WARRANTY, AN OPERATING LOG MUST BE MAINTAINED AND COPIES WILL NEED TO BE SENT TO YOUR LOCAL DEALER OR DISTRIBUTOR FOR REVIEW.**

NOTE: PRIOR TO OPERATING OR SERVICING THE TITAN REVERSE OSMOSIS SYSTEM, THIS USER'S MANUAL MUST BE READ AND FULLY UNDERSTOOD. KEEP IT AND OTHER ASSOCIATED INFORMATION FOR FUTURE REFERENCE AND FOR NEW OPERATORS OR QUALIFIED PERSONNEL NEAR THE SYSTEM.

SAFETY

The Safety section of this User's Manual outlines the various safety headings used throughout this manual's text and are enhanced and defined below:

NOTE: INDICATES STATEMENTS THAT PROVIDE FURTHER INFORMATION AND CLARIFICATION.

CAUTION: INDICATES STATEMENTS THAT ARE USED TO IDENTIFY CONDITIONS OR PRACTICES THAT COULD RESULT IN EQUIPMENT OR OTHER PROPERTY DAMAGE.

WARNING: INDICATES STATEMENTS THAT ARE USED TO IDENTIFY CONDITIONS OR PRACTICES THAT COULD RESULT IN INJURY OR LOSS OF LIFE. FAILURE TO FOLLOW WARNINGS COULD RESULT IN SERIOUS INJURY OR EVEN DEATH.

LABELING

Do not under any circumstance; remove any Caution, Warning, or other descriptive labels from the system.

SYSTEM SPECIFICATIONS

Model	Titan 10000	Titan 15000	Titan 20000
Gallons Per Day	10000	15000	20000
Element Size (in)	HF1 - 4040	HF1 - 4040	HF1 - 4040
Number of Elements	6	8	10
Pressure	150 psi	150 psi	150 psi
Motor HP	3	3	3 - 5
Voltages	220/380/460V 1/3PH	220/380/460V 1/3PH	220/380/460V 3PH
Hertz	50/60	50/60	50/60
Feed-Product-Waste	2", 1", 1"	2", 1", 1"	2", 1", 1"
Minimum Feed (gpm)	14	21	28
Recycle Line	Optional	Optional	Optional
Recovery*	33% – 50%	33% – 50%	33% – 50%
Dimensions (approx.)	49" x 33" x 54"	55" x 33" x 54"	61" x 33" x 54"
Weight (lbs.)	350 lbs.	400 lbs.	450 lbs.

* Recovery ratio may vary between 33% – 50% and up to 75% if system projections have been provided.

FEED WATER & OPERATION SPECIFICATIONS

Nothing has a greater effect on a reverse osmosis system than the feed water quality. **NOTE: IT IS VERY IMPORTANT TO MEET THE MINIMUM FEED WATER REQUIREMENTS. FAILURE TO DO SO WILL CAUSE THE MEMBRANES TO FOUL AND VOID THE MANUFACTURER'S WARRANTY.**

Feed Water Specifications			
Free Chlorine	<0 ppm	Manganese	<0.05 ppm
Total Dissolved Solids	<2000 ppm	Organics	<1 ppm
Turbidity (SDI)	<5	Silica	<1 ppm
pH	3 - 11	Iron	<2 ppm in Concentrate
Temperature	40°F - 105°F	Hardness	<15 gpg

The manufacturer has provided you with the suggested operation specifications. These specifications should be met in order to have the reverse osmosis system perform optimally. All operation specifications are based on the test conditions listed below.

Operating Specifications			
Minimum Feed Pressure	35 psi	Minimum NaCl Rejection	96%
Nominal % Rejection	98.5%	Maximum Hardness	15 gpg
Maximum TDS	2000 ppm	Operating Pressure	150 psi
pH Range	3 - 11	Maximum Temperature	105°F

Test Conditions: Permeate flow and salt rejection based on 550 ppm , 150 psi, 77°F (25°C), pH 7, and 50% recovery or as indicated.

NOTE: HIGHER TDS AND/OR LOWER TEMPERATURES WILL REDUCE THE SYSTEM'S PRODUCTION.

REJECTION, RECOVERY, & FLOW RATES

Titan reverse osmosis systems are designed to produce purified water at the capacities indicated by the suffix in the system's name under the conditions listed above. For example, the Titan 10000 produces 10000 gallons per day of purified water at the listed operating test conditions.

The amount of total dissolved solids (TDS) rejected by the membrane is expressed as a percentage. For example, a 99% rejection rate means that 99% of total dissolved solids do not pass through the membrane. To calculate the % rejection, use the following formula:

$$\% \text{ Rejection} = [(\text{Feed TDS} - \text{Product TDS}) / \text{Feed TDS}] \times 100$$

NOTE: ALL TDS FIGURES MUST BE EXPRESSED IN THE SAME UNITS, USUALLY PARTS PER MILLION (PPM) OR MILLIGRAMS PER LITER (MG/L).

Titan reverse osmosis systems are designed to reject up to 98.5% NaCl, unless computer projections have been provided and state a different rejection percentage.

The amount of purified water recovered for use is expressed as a percentage. To calculate % recovery, use the following formula:

$$\% \text{ Recovery} = (\text{Product Water Flow Rate} / \text{Feed Water Flow Rate}) \times 100$$

NOTE: ALL FLOW RATES MUST BE EXPRESSED IN THE SAME UNITS, USUALLY GALLONS PER MINUTE (GPM).

SYSTEM REQUIREMENTS & OPERATION GUIDELINES

PLUMBING

The membranes and high pressure pumps used on Titan systems require a continuous flow of water with a minimum feed pressure of 35 psi, which does not exceed 105°F.

The piping for the feed line is a 2" FNPT. This is from the 18"FSI bag filter housing.

The piping used for the concentrate line is 1" FNPT and should be run to an open drain in a free and unrestricted manner (no backpressure).

The piping used for the permeate line is 1" FNPT and can be run to the holding tank or directly to the point-of-use application with PVC pipe, or another FDA approved material This is so the material being used does not dissolve into the permeate water. Be certain that all of the components of the feed water are soluble at the concentrations attained in the system. A system operating at 50% recovery, concentrates all impurities by twice the amount.

CAUTION: ANY RESTRICTIONS OR BLOCKAGE IN THE DRAIN LINE CAN CAUSE BACKPRESSURE, WHICH WILL INCREASE THE SYSTEM'S OPERATING PRESSURE. THIS CAN RESULT IN DAMAGE TO THE SYSTEM'S MEMBRANES AND COMPONENTS.

ELECTRICAL

The motors used on Titan 10000, 15000 and 20000 systems are pump and motor combinations. The standard Titan 10000 and 15000 are available in 220/380/460V 1/3 Phase and the Titan 20000 is available in 220/380/460V 3 Phase.

Please ensure that the electrical circuit supplying the system is compatible with the requirements of the specific Titan model you are installing.

NOTE: WE RECOMMEND THAT A LICENSED ELECTRICIAN WIRE YOUR SYSTEM IN ACCORDANCE WITH LOCAL AND NATIONAL ELECTRICAL CODES (NEC).

WARNING: TO REDUCE THE RISK OF ELECTRICAL SHOCK, THE INCOMING POWER SUPPLY MUST INCLUDE A PROTECTIVE EARTH GROUND.

Each Titan system is equipped with a 5 foot electrical cord.

PRE-FILTRATION

Titan systems are supplied with a 10 Micron FSI Bag Filter and a 4.5" x 20" 5 Micron polypropylene sediment filter. Change the cartridge at least every month or when a 10-15 psi differential exists between the two pre-filters. Ask your local dealer or distributor about a Water Softener and/or Filtration systems.

NOTE: THE SYSTEM MUST BE OPERATED ON FILTERED WATER ONLY. DO NOT ATTEMPT TO CLEAN USED FILTER CARTRIDGES.

PUMP

The pumps used on the Titan 10000, 15000 & 20000 systems are centrifugal multi-stage pumps. These pumps are also available in stainless steel. Follow these guidelines to ensure proper operation of the pump:

- The pump must **NEVER** be run dry. Operating the pump without sufficient feed water will damage the pump.
- **ALWAYS** feed the pump with filtered water. The pump is susceptible to damage from sediment and debris.
- If any damage occurs to your system's pump, a re-build kit may be available. Contact your local dealer or distributor and inform them of your system's model and pump size.

MOUNTING

The free standing system should be bolted down in compliance with local regulation standards or securely fastened.

MEMBRANE ELEMENTS

Titan reverse osmosis systems come pre-loaded with Thin Film Composite (TFC) High Flow Low Energy membranes, unless otherwise specified. General membrane element performance characteristics are listed below:

Membrane Element Characteristics			
Operating Pressure	150 psi	Maximum Pressure	400 psi
Nominal % Rejection	98.5%	Chlorine Tolerance	<1 ppm
Maximum Temperature:	110°F	Turbidity	1 NTU
Silt Density Index	<5 SDI	pH Range	3 – 11
<p>Test Conditions: Permeate flow and salt rejection based on 550 ppm, 150 psi, 77°F (25°C), pH 7, and 15% recovery. NOTE: HIGHER TDS AND/OR LOWER TEMPERATURES WILL REDUCE THE MEMBRANE'S PRODUCTION.</p>			

START-UP

Unless otherwise indicated, these instructions cover the Titan™ 10000, 15000, & 20000 reverse osmosis systems. Please refer to the flow diagrams and exploded view diagrams found in this User's Manual for additional information and reference.

INSTALLATION

Titan reverse osmosis systems must be securely mounted and placed on an even floor, so that the system will not vibrate or move. If this occurs, place the system on a rubber mat to reduce the vibrations and movement. If you remove the caster wheels from the system's frame then properly mount the system to the ground.

Carefully inspect your system before start-up. Check that all plumbing and electrical connections are not loose or have not come undone during shipment. A User's Manual, Test Results, and Filter Housing Wrench will accompany your Titan reverse osmosis system.

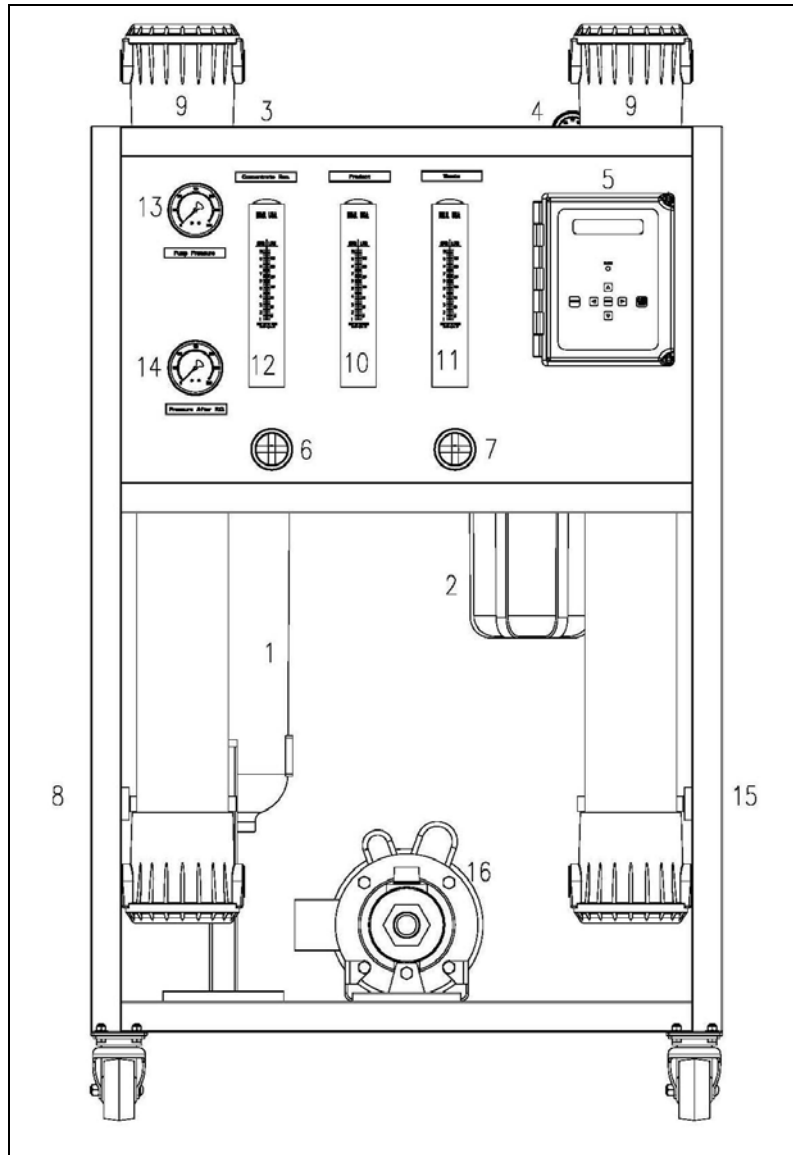

Number Identification

1. 10 micron Bag Filter – Removes particulates
2. 5 micron Sediment- Removes particulates
3. Pressure Gauge- Measures feed pressure
4. Pressure Gauge- Measures pressure after filters
5. RO Computer - Controls RO system
6. Recycle Valve – Recycles concentrate back to feed (If Applicable)
7. Concentrate Valve – Controls flow of waste (concentrate) water to the drain
8. Permeate Out- Connect this to your storage tank (POU)
9. Pressure Vessels – Holds Membranes
10. Flow Meter – Measures flow of permeate water
11. Flow Meter – Measures flow of concentrate water
12. Flow Meter - Measures flow of concentrate recycle (If Applicable)
13. Pressure Gauge – Measures Pump feed pressure
14. Pressure Gauge – Measures pressure after Membrane
15. Concentrate Out - Connect this to an open drain
16. RO Pump- Pressurizes RO System

SYSTEM PURGING

NOTE: LEAVE THE POWER TO THE SYSTEM OFF FOR THIS PROCEDURE.

1. Redirect permeate water to the drain for this procedure.
2. Fully open the concentrate valve # 7 (Counter Clockwise).
3. Fully close the recycle valve # 6 (Clockwise)(If Applicable).
4. Fully open the bypass valve to lower the pump pressure.
5. Offset the position of the bypass white lever on the solenoid valve.
6. Turn the feed water on and let the system purge until no visible bubbles appear from concentrate flow meter # 11.
7. See page 5 for Number Identification. Use this procedure when starting up a new system or when membranes are being replaced.

INITIAL START-UP (AFTER PURGING)

1. Fully open concentrate valve # 7 (Counter Clockwise).
2. Fully close recycle valve # 6 (Clockwise)(If Applicable).
3. Fully open bypass valve mounted on RO pump.
4. Return position of bypass white lever on the solenoid valve.
5. Turn RO system on # 5 and adjust bypass valve, concentrate (waste) valve # 7 and recycle valve # 6 (If Applicable) to designed flow and pressure.
6. Inspect for leaks and after one hour shut down the system. Re-direct permeate back to tank or POU and then turn sytem back on.
7. Record readings on a daily basis for one week and then once a week there on after.
8. See Page 5 for Number Identification. See below for detailed startup procedures.

START-UP

1. Locate the 2" FNPT feed water inlet on the 18" FSI bag filter housing.
2. Attach the inlet piping to the 2" FNPT feed water inlet. Always maintain a smooth and sufficient flow of feed water during operation.
3. Locate the concentrate outlet on the drain side of the concentrate control valve.
4. Attach the drain line to the concentrate outlet. Water must be allowed to run freely, without any restrictions or blockage in the drain line. Make sure that no backpressure exists on the concentrate line.
5. Ensure that the electrical power requirements of the Titan system match your electrical power supply.
6. Titan systems are typically controlled with a liquid level switch in a storage tank. The liquid level switch turns the system on when the water level in the tank drops, and off when the tank is full. The level control is connected to the level control connections in the control box. The level control connections are dry contacts and should never have power applied to the connections. Liquid level switches can be obtained by your local dealer or distributor. If a liquid level switch is to be used, install it at this time.
7. Direct the permeate line to the drain. Flush the system for approximately 15 minutes with the feed water by fully opening the concentrate valve counter-clockwise. This will assist in removing any impurities or preservative within the system. At this time check for any wetted parts which may have been damaged during shipment. After 15 minutes shut down the feed water.
8. Locate the 1" FNPT permeate outlet.
9. Attach the permeate piping to the permeate outlet. Make sure that the permeate water can flow freely and that there is no backpressure. Backpressure can cause damage to the membrane elements.

CAUTION: THE PLUMBING IN THE PERMEATE LINE CAN CONTAMINATE THE HIGH QUALITY WATER PRODUCED BY THE SYSTEM; ENSURE THAT THE COMPONENTS ARE COMPATIBLE WITH THE APPLICATION. THE PH OF THE REVERSE OSMOSIS PERMEATE WATER WILL NORMALLY BE 1-2 POINTS LOWER THAN THE FEED WATER PH. A LOW PH CAN BE VERY AGGRESSIVE TO PLUMBING MATERIALS SUCH AS COPPER PIPING.

10. Turn on the power to the system.
11. Follow any specified system projections supplied.
12. Locate the concentrate control valve and the concentrate pressure gauge.
13. Turn the concentrate control valve until the designated recovery is acquired. The concentrate pressure will increase as the concentrate control valve is closed. The exact operating pressure may vary depending on the temperature and TDS of your feed water. It may be necessary to re-adjust the system if there is a major change in feed water temperature and TDS.
14. Adjust the pump bypass valve until the desired pump pressure is achieved. For example a Titan 10000 should be adjusted until it produces about 10000 GPD or 6.94 GPM of permeate or product water. The system's maximum operating pressure is based on the pumps limitations or the pressure vessels being utilized. Refer to the specification sheets for the above products on the specific pressures being utilized.

GPM = GPD/1440

WARNING: Never exceed the maximum pressure rating of your pressure vessels.

OPERATION & MAINTENANCE

The reverse osmosis process causes the concentration of impurities. The impurities may precipitate (come out of solution) when their concentration reaches saturation levels. **NOTE: PRECIPITATION CAN SCALE OR FOUL MEMBRANES AND MUST BE PREVENTED.**

Check your feed water chemistry and pre-treat the water and/or reduce the system's recovery as required. If necessary, consult with your local dealer or distributor.

PRE-FILTER PRESSURE GAUGES

These gauges measure the feed water pressure when it enters and exits the pre-filter housings. A pressure differential of 10 - 15 psi or more on the two pressure gauges indicates that the pre-filters require servicing. For example, if the inlet pressure is 40 psi, the filter should be changed when the outlet pressure is 30 psi or below.

PRODUCT (PERMEATE) FLOW METER & WASTE (CONCENTRATE) FLOW METER

These flow meters indicate the flow rates of the permeate and concentrate water. The measurements, when added together, also indicate the feed water flow rate or (total flow rate); if the system is not equipped with a concentrate recycle valve.

WASTE (CONCENTRATE) RECYCLE VALVE

This valve allows you to recycle a portion of the concentrate water back into the feed of the pump, thus increasing the recovery ratio of the Titan System. This will increase the recovery of the Titan™ system. An optional waste recycle flow meter allows you to measure how much concentrate is recycled. The amount of waste water recycled is limited by the TDS of the feed water. The drawback of using a concentrate recycle is that there will be an increase of total dissolved solids in the permeate water.

CAUTION: EXCESSIVE RECYCLING MAY CAUSE PREMATURE FOULING OR SCALING OF THE MEMBRANE ELEMENTS.

The concentrate recycle valve allows you to recycle a portion of the concentrate water back into the feed of the pump, thus increasing the recovery ratio of the Titan System. An optional waste recycle flow meter allows you to measure how much concentrate is recycled. The amount of waste water recycled is limited by the TDS of the feed water. The drawback of using a concentrate recycle is that there will be an increase of total dissolved solids in the permeate water.

RO CONTROLLER

The RO Controller is located on the front panel of the Titan System. The controller has numerous programmable capabilities built in. The controller also displays feed water temperature, system operating hours and has a built in TDS monitor.

LOW PRESSURE SWITCH

There is a low pressure cut-off switch which monitors the system's feed water pressure. The pressure switch will signal the RO controller to shut down once it senses a loss of pressure. If set, it will automatically attempt restart after several minutes.

AUTO FLUSH

The auto flush option bypasses the concentrate control valve, reducing the concentrate pressure and increasing the flow of feed water across the membrane. The auto flush removes foulants that may have attached to the surface of the membrane. By removing these foulants before they crystallize on the surface of the membrane, the system can operate longer without cleaning and/or replacing the membrane elements. The following are instances in which the auto-flush should be utilized:

1. When injecting antiscalant chemicals. Antiscalants will keep scaling ions in solution at higher concentration levels to prevent precipitation and scaling of the membranes.
2. For feed water with a high scaling potential (hard water) in addition to the auto flush, pre-treat the water with an antiscalant or a water softener.
3. Where minimal maintenance is important, auto flush can increase the time between membrane cleanings.
4. For high TDS (total dissolved solids) applications where the TDS exceeds 550 ppm.
5. For higher recovery applications (that use a recycle valve).
6. For systems that may remain inoperative for long periods of time, auto-flush should be installed. The auto-flush will not operate if the electrical power is removed from the system.

NOTE: SOME PERMEATE WILL BE PRODUCED DURING THE AUTO FLUSH; THEREFORE, AN OVERFLOW FOR THE PERMEATE STORAGE TANK IS RECOMMENDED.

PUMP BYPASS VALVE

The pump bypass valve is installed as a standard feature on the Titan 10000, 15000, & 20000 reverse osmosis systems. It provides an adjustment for pump pressure, which will vary as the required system pressure changes. As the feed water temperature decreases, and/or the feed water TDS increases, the system will require a higher operating pressure to produce the specified permeate flow. A Titan system installed in Florida may provide the specified permeate flow of 10.42 gpm at 150 psi; however the same system installed in Maine – much colder feed water – may require 190 psi to produce the same amount of permeate.

$$\% \text{ Rejection} = (\text{Feed TDS} - \text{Product TDS}) / (\text{Feed TDS}) \times 100$$

MEMBRANE REMOVAL & REPLACEMENT

Changing membranes in pressure vessels is an easy process if you have the proper information and tools at hand. Please refer to the following instructions when removing and replacing membrane elements:

1. Remove the end caps from the top of the membrane housings. This is done by removing the white Nylon snap ring of the Champ housing or unscrewing the bolts of the PuroTech housing, which holds the clamp in place.
2. Remove the membrane bag containing the membrane element from the shipping box.
3. Cut the bag open as close as possible to the seal at the end of the bag, so the bag may be re-used if necessary.
4. Remove parts from the parts container (if included) and inspect. Make sure that all parts are clean and free from dirt. Examine the brine seal, and permeate tube for nicks or cuts. Replace the O-rings or brine seal if damaged.
5. Flow directions should be observed for installation of each element into each housing.

As time progresses, the efficiency of the membrane will be reduced. In general, the salt rejection does not change significantly until two or three years after installation when operated on properly pretreated feed water. The permeate flow rate will begin to decline slightly after one year of operation, but can be extended with diligent flushing and cleaning of the system. A high pH and/or precipitation of hardness can cause premature loss in rejection of membrane elements in the system.

To replace the membrane elements:

1. Remove all of the membrane element(s) from the membrane element housings from the top of the housing. Heavy-duty pliers and channel lock pliers may be necessary to pull the old membrane element out of the membrane element housing.
2. Install the brine seal side of the membrane elements first. When the housings have a direction of flow from bottom to top, the brine seal should be located on the end of the membrane element at the bottom of the housing.
3. Lubricate the brine seal with a food grade lubricant.
4. At a slight angle insert membrane while slightly rotating element being careful not to tear or flip the brine seal. Re-lube the brine seal if necessary.
5. With a smooth and constant motion, push the membrane element into the housing so that the brine seal enters the housing without coming out of the brine seal groove. A slow twisting motion should be used to insert the membrane element, to ensure that the brine seal stays in place.
6. Re-install the end caps by gently twisting the end cap while pushing it onto the housing. Ensure that you do not pinch or fatigue any O-rings while pushing the end plug on. Push the end plug on until the outer diameter of the plug is flush with the outer diameter of the membrane housing.
7. Insert nylon snap ring until fully seated. Snap ring must be able to be spun in place if fully seated. If you are using stainless steel housing, install the clamps, and tighten bolts until the clamps meet.
8. Reconnect any fittings that may have been disconnected when the membrane element housings were disassembled.
9. To Start-Up the system, refer to Start-Up

CAUTION: SOME NEW OR FACTORY CLEANED MEMBRANES ARE SHIPPED IN A PRESERVATIVE SOLUTION. THE MEMBRANES MUST BE FLUSHED FOR AT LEAST 1 HOUR TO REMOVE THE PRESERVATIVE FROM THE MEMBRANE. DISCARD ALL OF THE PERMEATE AND CONCENTRATE, WHICH IS PRODUCED DURING THE FLUSH.

MEMBRANE CLEANING

Periodic cleaning of the membrane(s) can improve system performance. In normal operation, mineral scale, biological matter, colloidal particles, and organic substances can foul the membranes.

WARNING: CLEANING CHEMICALS ARE DANGEROUS AND CAN CAUSE INJURY AND DAMAGE TO THE ENVIRONMENT. READ AND COMPLY WITH ALL SAFETY AND DISPOSAL PRECAUTIONS LISTED ON THE MATERIAL SAFETY DATA SHEETS (MSDS'S). IT IS THE USER'S RESPONSIBILITY TO COMPLY WITH ALL APPLICABLE FEDERAL, STATE, AND LOCAL REGULATIONS.

ORGANIC FOULANT CLEANING

The following cleaning procedures are designed specifically for membranes that have been fouled with organic matter. Review the general cleaning instructions for information that is common to all types of cleaning such as suggested equipment, pH and temperature limits, and recommended flow rates.

SAFETY PRECAUTIONS

1. When using any chemical indicated here in subsequent sections, follow accepted safety practices. Consult the chemical manufacturer for detailed information about safety, handling and disposal.
2. When preparing cleaning solutions, ensure that all chemicals are dissolved and well mixed before circulating the solutions through the membrane elements.
3. It is recommended the membrane elements be flushed with good-quality chlorine-free water after cleaning. Permeate water is recommended; but a de-chlorinated potable supply or pre-filtered feed water may be used, provided that there are no corrosion problems in the piping system. Operate initially at reduced flow and pressure, to flush the bulk of the cleaning solution from the elements before resuming normal operating pressures and flows. Despite this precaution, cleaning chemicals will be present on the permeate side following cleaning. Therefore, permeate must be diverted to drain for at least 10 minutes or until the water is clear when starting up after cleaning.
4. During recirculation of cleaning solutions, the temperatures must not exceed 50°C at pH 2-10, 35°C at pH 1-11, and 30°C at pH 1-12.
5. For membrane elements greater than six inches in diameter, the flow direction during cleaning must be the same as during normal operation to prevent element telescoping, because the housing thrust ring is installed only on the reject end of the housing. This is also recommended for smaller elements.

CLEANING PROCEDURES

There are seven steps in cleaning membrane elements with organics.

1. Make up the cleaning solution listed from Table 1.

Table 1: Organic Cleaning Solution

- Preferred 0.1% (wt) Soda Ash
- PH 12, 30°C maximum
- Preferred 0.1% (wt) NaOH 0.025% (wt)
- PH 12, 30°C maximum

Notes:

(wt): Denotes weight percent of active ingredient.
Cleaning chemical symbols in order used: NaOH is sodium hydroxide.

CLEANING THE ORGANICS FROM MEMBRANE ELEMENTS

2. Low-flow pumping. Pump mixed, preheated cleaning solution to the vessel at conditions of low flow rate (about half of that shown in Table 2) and low pressure to displace the process water. Use only enough pressure to compensate for the pressure drop from feed to concentrate. The pressure should be low enough that essentially no permeate is produced. A low pressure minimizes re-deposition of dirt on the membrane. Dump the concentrate, as necessary, to prevent dilution of the cleaning solution.

Table 2: Recommended Feed Flow Rate Per Housing During High Flow Rate Re-Circulation

- Dependent on number of elements in pressure vessel.
 - 4-Inch full-fit elements should be cleaned at 12-14 gpm (2.7-3.2 m3/hr).
3. Re-circulate. After the process water is displaced, cleaning solution will be present in the concentrate stream that can be recycled to the cleaning solution tank. Recycle the cleaning solution for 15 minutes or until there is no visible color change. If a color change occurs, dispose of the cleaning solution and prepare a new solution as described in step 2.
 4. Soak. Turn the pump off and allow the elements to soak. Soak the elements for 1-15 hours (soaking overnight will give best results). To maintain temperature during an extended soak period, use a slow recirculation rate (about 10 percent of that shown in Table 2). Soak time will vary depending on the severity of the fouling. For lightly fouled systems, a soak time of 1-2 hours is sufficient.
 5. High-flow pumping. Feed the cleaning solution at the rates shown in Table 2 for 45 minutes. The high flow rate flushes out the foulants removed from the membrane surface by the cleaning. If the elements are heavily fouled, using a flow rate that is 50 percent higher than shown in Table 2 may aid cleaning. At higher flow rates, excessive pressure drop may be a problem. The maximum recommended pressure drops are 15 psi per element or 50 psi per multi-element vessel, whichever value is more limiting.
 6. Flush out. Prefiltered raw water can be used for flushing out the cleaning solution, unless there will be corrosion problems (e.g., stagnant seawater will corrode stainless steel piping). To prevent precipitation, the minimum flush out temperature is 20°C. The system should be flushed for 1 hour.
 7. The system should be restarted. Elements and the system need to stabilize before taking any data. The stabilization period will vary depending on the severity of the fouling. To regain optimum performance, it may take several cleaning and soak cycles.

NOTE: RECOMMENDATIONS MADE HERE ARE SPECIFICALLY DESIGNED FOR THE MEMBRANE ELEMENTS INSERTED IN THE TITAN™ REVERSE OSMOSIS AND NANOFILTRATION ELEMENTS. THESE RECOMMENDATIONS, SUCH AS CLEANING PROCEDURES AND CHEMICALS EMPLOYED, MAY NOT BE COMPATIBLE WITH OTHER BRANDS OF MEMBRANE ELEMENTS. IT IS YOUR RESPONSIBILITY TO ENSURE THE SUITABILITY OF THESE RECOMMENDATIONS AND PROCEDURES IF THEY ARE APPLIED TO MEMBRANE ELEMENTS OTHER THAN THOSE WHICH COME WITH YOUR SYSTEM.

NOTE: NO FREEDOM FROM ANY PATENT OWNED BY SELLER OR OTHERS IS TO BE INFERRED. BECAUSE USE CONDITIONS AND APPLICABLE LAWS MAY DIFFER FROM ONE LOCATION TO ANOTHER AND MAY CHANGE WITH TIME, CUSTOMER IS RESPONSIBLE FOR DETERMINING WHETHER PRODUCTS AND THE INFORMATION IN THIS DOCUMENT ARE APPROPRIATE FOR CUSTOMER'S USE AND FOR ENSURING THAT CUSTOMER'S WORKPLACE AND DISPOSAL PRACTICES ARE IN COMPLIANCE WITH APPLICABLE LAWS AND OTHER GOVERNMENTAL ENACTMENTS. SELLER ASSUMES NO OBLIGATION OR LIABILITY FOR THE INFORMATION IN THIS DOCUMENT. NO WARRANTIES ARE GIVEN; ALL IMPLIED WARRANTIES OF MERCHANTABILITY OR FITNESS FOR A PARTICULAR PURPOSE ARE EXPRESSLY EXCLUDED.

ADDITIONAL INFORMATION

By experience, the cleaning solution of Na4EDTA with caustic has been found to be slightly less effective than a standard caustic solution or a solution of caustic and Na-DSS. For any solution, contact time is critical. Several overnight soaks may be necessary to restore the system performance. After the elements are clean it is very beneficial to clean one additional time in order to clean off the last remaining biofilm layer on the surface of the membrane. Any remaining biofilm will tend to attract and trap dirt, so an extra cleaning will increase the time between cleanings. For industrial systems where the permeate or product water is not used for drinking, a non-oxidizing biocide can be used prior to step 1 of the cleaning procedure to kill any bacteria or biofilm in the system. Please refer to separate instructions on methods for sanitizing membrane systems (i.e., "Sanitization with DBNPA - Tech Facts"). If the only choice for a sanitizing agent is an oxidant, such as hydrogen peroxide, the system must be cleaned before sanitization.

INORGANIC FOULANT CLEANING

The following cleaning procedures are designed specifically for membranes that have been fouled with organic matter. Review the general cleaning instructions for information that is common to all types of cleaning such as suggested equipment, pH and temperature limits, and recommended flow rates.

SAFETY PRECAUTIONS

1. When using any chemical indicated here in subsequent sections, follow accepted safety practices. Consult the chemical manufacturer for detailed information about safety, handling and disposal.
2. When preparing cleaning solutions, ensure that all chemicals are dissolved and well mixed before circulating the solutions through the membrane elements.
3. It is recommended the membrane elements be flushed with good-quality chlorine-free water after cleaning. Permeate water is recommended; but a de-chlorinated potable supply or pre-filtered feed water may be used, provided that there are no corrosion problems in the piping system. Operate initially at reduced flow and pressure, to flush the bulk of the cleaning solution from the elements before resuming normal operating pressures and flows. Despite this precaution, cleaning chemicals will be present on the permeate side following cleaning. Therefore, permeate must be diverted to drain for at least 10 minutes or until the water is clear when starting up after cleaning.
4. During recirculation of cleaning solutions, the temperatures must not exceed 50°C at pH 2-10, 35°C at pH 1-11, and 30°C at pH 1-12.
5. For membrane elements greater than six inches in diameter, the flow direction during cleaning must be the same as during normal operation to prevent element telescoping, because the housing thrust ring is installed only on the reject end of the housing. This is also recommended for smaller elements.

CLEANING PROCEDURES

There are seven steps in cleaning membrane elements with Inorganics.

1. Make up the cleaning solution listed from Table 1.

Table 1: Inorganic Cleaning Solution

- Preferred 2.0% (wt) Citric Acid PH 2, 45°C maximum
- Alternate Muriatic Acid

Notes:

(wt): denotes weight percent of active ingredient.

Cleaning chemical symbols in order used: HCl is hydrochloric acid (Muriatic Acid).

Cleaning the Inorganics from Membrane Elements

- Alternative 1.0% Na2S2O4
- Alternative 0.5% H3PO4

Notes:

(wt): denotes weight percent of active ingredient.

Cleaning chemical symbols in order used: HCl is hydrochloric acid (Muriatic Acid).

1. Low-flow pumping. Pump mixed, preheated cleaning solution to the vessel at conditions of low flow rate (about half of that shown in Table 2) and low pressure to displace the process water. Use only enough pressure to compensate for the pressure drop from feed to concentrate. The pressure should be low enough that essentially no permeate is produced (approx. 60 psi). A low pressure minimizes redeposition of dirt on the membrane. Dump the concentrate, as necessary, to prevent dilution of the cleaning solution.

Table 2: Recommended Feed Flow Rate Per Housing During High Flow Rate Re-Circulation

Element Diameter	PSI	GPM
2.5 Inches	20 - 60	3 - 5
4 Inches	20 - 60	8 - 10

- Dependent on number of elements in pressure vessel.
- 4-Inch full-fit elements should be cleaned at 12-14 gpm (2.7-3.2 m³/hr).
- Re-circulate. After the process water is displaced, cleaning solution will be present in the concentrate stream that can be recycled to the cleaning solution tank. Recycle the cleaning solution for 10 minutes or until there is no visible color change. If at anytime during the circulation process there is a change in pH or a color change, dispose of the solution and prepare a new solution as described in step 2. A pH of 2 must be maintained for the cleaning to be effective.
- Soak. Turn the pump off and allow the elements to soak. Soak the elements for 1-15 hours (soaking overnight will give best results). To maintain temperature during an extended soak period, use a slow recirculation rate (about 10 percent of that shown in Table 2). Soak time will vary depending on the severity of the scaling. For lightly scaled systems, a soak time of 1-2 hours is sufficient.
- High-flow pumping. Feed the cleaning solution at the rates shown in Table 2 for 10 minutes. The high flow rate flushes out the foulants removed from the membrane surface by the cleaning. If the elements are heavily fouled, using a flow rate that is 50 percent higher than shown in Table 2 may aid cleaning. At higher flow rates, excessive pressure drop may be a problem. The maximum recommended pressure drops are 15 psi per element or 50 psi per multi-element vessel, whichever value is more limiting.
- Flush out. Prefiltered raw water can be used for flushing out the cleaning solution, unless there will be corrosion problems (e.g., stagnant seawater will corrode stainless steel piping). To prevent precipitation, the minimum flush out temperature is 20°C. The system should be flushed for one hour.
- The system should be restarted. Elements and the system need to stabilize before taking any data. The stabilization period will vary depending on the severity of the fouling. To regain optimum performance, it may take several cleaning and soak cycles.

NOTE: RECOMMENDATIONS MADE HERE ARE SPECIFICALLY DESIGNED FOR THE MEMBRANE ELEMENTS INSERTED IN THE TITAN™ REVERSE OSMOSIS AND NANOFILTRATION ELEMENTS. THESE RECOMMENDATIONS, SUCH AS CLEANING PROCEDURES AND CHEMICALS EMPLOYED, MAY NOT BE COMPATIBLE WITH OTHER BRANDS OF MEMBRANE ELEMENTS. IT IS YOUR RESPONSIBILITY TO ENSURE THE SUITABILITY OF THESE RECOMMENDATIONS AND PROCEDURES IF THEY ARE APPLIED TO MEMBRANE ELEMENTS OTHER THAN THOSE WHICH COME WITH YOUR SYSTEM.

NOTE: NO FREEDOM FROM ANY PATENT OWNED BY SELLER OR OTHERS IS TO BE INFERRED. BECAUSE USE CONDITIONS AND APPLICABLE LAWS MAY DIFFER FROM ONE LOCATION TO ANOTHER AND MAY CHANGE WITH TIME, CUSTOMER IS RESPONSIBLE FOR DETERMINING WHETHER PRODUCTS AND THE INFORMATION IN THIS DOCUMENT ARE APPROPRIATE FOR CUSTOMER'S USE AND FOR ENSURING THAT CUSTOMER'S WORKPLACE AND DISPOSAL PRACTICES ARE IN COMPLIANCE WITH APPLICABLE LAWS AND OTHER GOVERNMENTAL ENACTMENTS. SELLER ASSUMES NO OBLIGATION OR LIABILITY FOR THE INFORMATION IN THIS DOCUMENT. NO WARRANTIES ARE GIVEN; ALL IMPLIED WARRANTIES OF MERCHANTABILITY OR FITNESS FOR A PARTICULAR PURPOSE ARE EXPRESSLY EXCLUDED.

ADDITIONAL INFORMATION

Never recirculate the cleaning solution for longer than 20 minutes. With longer recirculation, the carbonate scale can reprecipitate and end up back on the membrane surface, making it more difficult to clean. Carbonate scale reacts with HCl releasing carbon dioxide gas. Depending on the severity of the fouling, it may take repeated cleanings to remove all the scale. Cleaning severe scale may not be economical and element replacement may be the best choice.

Citric acid was originally used as a cleaner for cellulose acetate membranes and is not as effective with thin film composite chemistry. Further, it has a disadvantage of being a nutrient source for systems, which have biological fouling. It is, however, easier to handle than HCl and is included as a primary cleaner for that reason.

FLUSHING THE SYSTEM

The system should be flushed weekly to remove sediment from the surface of the membranes. To manually flush the system following the preceding steps:

1. The system must be running during the flushing procedure.
2. Fully open the concentrate valve

3. Allow the system to run for 10 to 20 minutes.
4. After 10 to 20 minutes, close the concentrate valve to its previous position. Ensure the proper concentrate flow rate is going to the drain.
5. The system is now ready to operate.

DRAINING THE SYSTEM FOR SHIPMENT

Prior to shipping or storing your system, the system should be cleaned with an appropriate cleaner, flushed with water, and protected from biological attack with an appropriate solution for membrane elements. The membrane housing(s) and plumbing lines of the system must be completely drained. Any water remaining in the plumbing of a system may freeze, causing serious damage. The party shipping or storing the system is responsible for any damage resulting from freezing.

To drain the system:

1. Disconnect the inlet, concentrate, pre-filter, and permeate plumbing.
2. Drain all water from the pre-filter cartridge housings by unscrewing the housings, removing the pre-filter cartridges, and drain the water from the housings.
3. Disconnect the tubing from the connector on the permeate and concentrate inlets and outlets.
4. Fully open the concentrate valve.
5. Drain the flow meters by disconnecting the tubing from the bottom fitting of each meter.
6. Allow the system to drain for a minimum of eight hours or until the opened ports quit dripping.
7. After draining is complete, reconnect all of the plumbing.

TROUBLESHOOTING

If the system production declines or the system stops working, check the mechanical components for any visual problems. Listed below are the items to check for any visual problems. Listed are two of the most commonly encountered problems; low system pressure and abnormal permeate flow. Also refer to the reverse osmosis troubleshooting matrix.

LOW SYSTEM PRESSURE

Low system pressure occurs when insufficient feed water pressure and flow are not obtained. This causes the low pressure switch to trigger a low pressure fault and to shut the system down in order to protect the pump.

1. Pre-Filter:

Check the differential in the pre-filter gauges to determine if the filter needs to be replaced. There should be no more than a 15 psi pressure differential between the two pre-filter gauges. Replace the pre-filters if necessary.

2. Low Feed Water Flow Rate:

Determine that the system is getting a sufficient volume of feed water. Disconnect the feed water hose from the system and place it in a one gallon bucket. Measure the time it takes to fill the bucket to determine the feed flow. (Feed flow is measured in gallons per minute, so divide 1 gallon by the time in minutes to obtain the flow rate). Refer to the System Specifications for the required feed flow.

3. Inlet Solenoid Valve:

Feed water enters the system through an automatic solenoid shut-off valve, which is normally closed. Ensure that the solenoid opens when the reverse osmosis pump starts. The system can be operated without the solenoid for troubleshooting. Remove the solenoid to see if it is contributing to the problem. Normally, cleaning the solenoid diaphragm will correct any malfunction of the solenoid.

4. Electrical:

Check to ensure that there are no electrical fuses or circuit breakers blown and that all electrical connections are secure. Use a voltmeter to verify that the system is getting sufficient power.

5. Pressure Gauge:

Check for foreign matter on the gauge fitting. Remove any visible matter and replace the fitting. Verify that the tube is not pushed too far inside the fitting. This could restrict flow and cause an inaccurate display. If the fitting and tube are fine and the pressure gauge is still malfunctioning, the gauge should be replaced.

6. Concentrate Control Valve:

The concentrate control valve may have a tear in the o-ring. Remove the valve, inspect the diaphragm, and replace if necessary.

7. Motor:

The motor may not be drawing the correct current. Use a clamp-on amp meter to check the current draw.

8. Leaks:

Check the system for leaks, as this can result in low pressure.

ABNORMAL PERMEATE FLOW

Permeate flow should be within 15% of the rated production, after correcting the feed water temperatures above or below 77°F. Check your permeate flow meter to determine the permeate flow rate. If the system does not have a permeate flow meter, measure the time it takes to fill a 1 gallon container then calculate the permeate flow rate at gallons per minute or gallons per day.

NOTE: To determine the temperature correction factor, locate the Temperature Correction Table in this User's Manual and follow the directions.

1. Causes of Low Permeate Flow:

- Cold Feed Water
- Low Operating Pressure
- Defective Membrane Brine Seal
- Fouled or Scaled Membrane

2. Causes of High Permeate Flow:

- Defective Product Tube O-Rings
- Defective or Oxidized Membrane

3. Causes of Poor Permeate Quality:

- Low Operating Pressure
- Defective Product Tube O-Rings
- Damaged or Oxidized Membrane

Reverse Osmosis System Troubleshooting						
Symptoms			Location	Possible Causes	Verification	Corrective Action
Salt Passage	Permeate Flow	Pressure Drop				
Normal to Increased	Decreased	Normal to Increased	Predominately First Stage	Metal Oxide Fouling	Analysis of Metal Ions in Cleaning Solution.	Improve pretreatment to remove metals. Clean with Acid Cleaners.
Normal to Increased	Decreased	Increased	Predominately First Stage	Colloidal Fouling	SDI Measurement of Feed Water.	Optimize pretreatment for colloid removal. Clean with high pH anionic cleaners.
Increased	Decreased	Increased	Predominately First Stage	Scaling (CaSO ₄ , CaSO ₃ , BaSO ₄ , SiO ₂)	Analysis of metal ions in cleaning solution by checking LSI of reject. Calculate max. solubility of CaSO ₄ , BaSO ₄ , SiO ₂ in reject.	Increase acid addition and antiscalant dosage for CaVO ₃ and CaCO ₄ . Reduce recovery. Clean with Acid Cleaners.
Normal to Moderate Increase	Decreased	Normal to Moderate Increase	Any Stage	Biological Fouling	Bacteria count in permeate and reject. Slime in pipes and pressure vessels.	Shock dosage of Sodium Bi-Sulfate. Continuous feed of Sodium Bi-Sulfate at reduced pH. Formaldehyde disinfection. Chlorination and de-chlorination. Replace cartridge filters.
Decreased or Slightly Increased	Decreased	Normal	Any Stage	Organic Fouling	Destructive Element Testing.	Activated Carbon or other pretreatment. Clean with high pH cleaner.
Increased	Increased	Decreased	Most Severe in First Stage	Chlorine Oxidation	Chlorine Analysis of feed water. Destructive element test.	Check Chlorine feed equipment and de-chlorination system.
Increased	Increased	Decreased	Most Severe in First Stage	Abrasion of membrane by Crystalline Material	Microscopic solids analysis of feed. Destructive element test.	Improve pretreatment. Check all filters for media leakage.
Increased	Normal to Increased	Decreased	At Random	O-Ring Leaks, End or Side Seal Leaks	Probe test. Vacuum test. Colloidal material test.	Replace O-Rings. Repair or replace elements.
Increased	Normal to Low	Decreased	At Random	Recovery Too High	Check Flows and Pressure Against Design Guidelines.	Reduce the recovery rate. Calibrate and/or add sensors.

TEMPERATURE GUIDE

Temperature Correction Factors For Membrane Flux			
TEMPERATURE		CA	TF
°C	°F	(Cellulose Acetate)	(Thin Film Composite)
10°	50°	1.468	1.711
11°	52°	1.429	1.648
12°	54°	1.391	1.588
13°	55°	1.355	1.530
14°	57°	1.320	1.475
15°	59°	1.286	1.422
16°	61°	1.253	1.371
17°	63°	1.221	1.323
18°	64°	1.190	1.276
19°	66°	1.160	1.232
20°	68°	1.132	1.189
21°	70°	1.104	1.148
22°	72°	1.076	1.109
23°	73°	1.050	1.071
24°	75°	1.025	1.035
25°	77°	1.000	1.000
26°	79°	0.988	0.971
27°	81°	0.976	0.943
28°	82°	0.964	0.915
29°	84°	0.953	0.889
30°	86°	0.942	0.863

To use: Simply multiply the actual flux to obtain temperature corrected flux.

SERVICE ASSISTANCE

If service assistance is required, please complete the following process:

Contact your local dealer or distributor. Prior to making the call, have the following information available: system installation date, serial number, daily log sheets, current operating parameters (e.g. flow, operating pressures, pH, etc.), and a detailed description of the problem.

SYSTEM WARRANTY/GUARANTEES

The system's manufacturer guarantees that the proposed product is to be free from any defects in material or workmanship when operated in accordance with written instructions for a period of one year (12 months) from start-up. Parts not manufactured by the system's manufacturer are covered by their manufacturer's warranties which are normally for one year. Please contact your local dealer or distributor for additional information regarding warranties.

Operation Log		
Company: _____	Date of Start-Up: _____	
Location: _____	Date of Last Cleaning: _____	
Week Of: _____	Cleaning Formulation: _____	
System Serial #: _____		
Date		
Time		
Hours of Operation		
Cartridge Filter Inlet Pressure (psi)		
Differential Pressure (psi)		
Permeate Pressure (psi)		
Feed Pressure (psi)		
Concentrate Pressure (psi)		
Differential Pressure (psi)		
Pump Discharge Pressure (psi)		
Permeate Flow (GPM)		
Concentrate Flow (GPM)		
Feed Flow (GPM)		
Recovery %		
Feed Temperature		
Feed Conductivity (mg/L)		
Permeate Conductivity (mg/L)		
Rejection %		
Feed pH		
Permeate pH		
Scale Inhibitor Feed (ppm)		
Acid Feed (ppm)		
Sodium Bisulfite Feed (ppm)		
Feed Water:		
Iron (mg/L)		
Free Chlorine (mg/L)		
Hardness (ppm CaCO₃)		
Turbidity (NTU)		

REVOLUTIONS		REV	DESCRIPTION	BY	DATE
A	ADDED NEW TEMPLATE	KT	12-28-07		

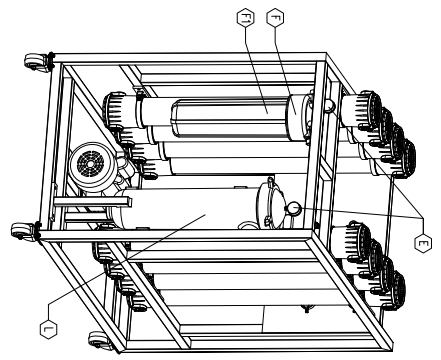
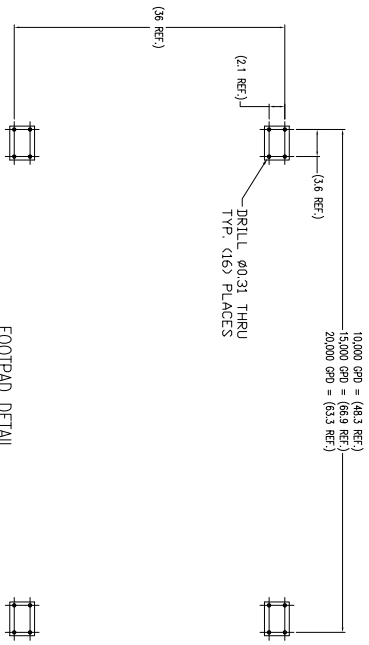
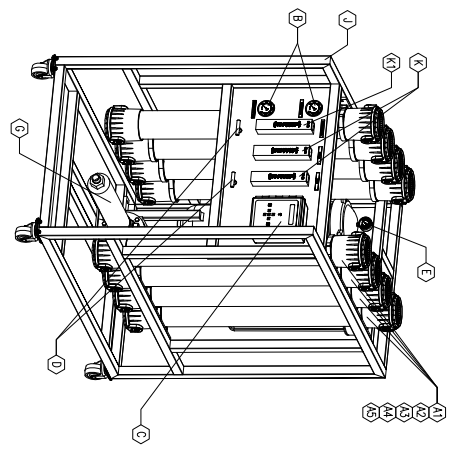
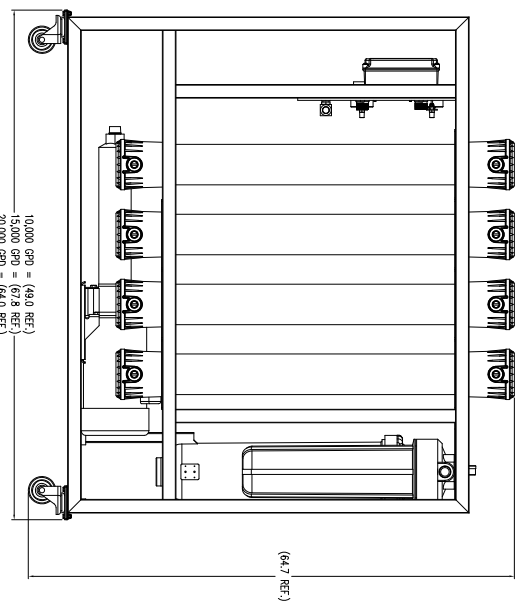
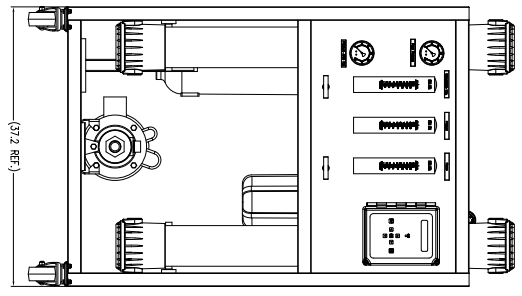

APPROXIMATE WEIGHTS
 R.O. 10,000 SYSTEM = LBS.
 R.O. 15,000 SYSTEM = LBS.
 R.O. 20,000 SYSTEM = LBS.

- NOTES:
1. ALL DIMENSIONS ARE GIVEN IN INCHES AND ARE APPROXIMATE.
 2. MODEL R.O. 15,000 (20-20-15000) IS SHOWN.
 3. PROVIDE A DRAIN CHARGE OF HANDING AT LEAST 2 GALONS PER MINUTE. DO NOT MAKE A DIRECT CONNECTION TO THE DRAIN. PROVIDE AN AIR GAP OF AT LEAST FOUR TIMES THE OBSERVATION OF THE DRAIN FLOW. CONNECTIONS SHALL BE MADE TO THE DRAIN LINE OF USE THE SMALLER THAN LISTED IN TABLE.
 4. PLUMBING CONNECTIONS
 FEES: 2" 1"
 1.5" 1"
 1" 1"
 CONSTRUCTION: 1"

PROPRIETARY AND CONFIDENTIAL
 THE INFORMATION CONTAINED IN THIS DRAWING IS THE SOLE PROPERTY OF QUINCY INDUSTRIES, INC. ANY REPRODUCTION IN PART OR AS A WHOLE WITHOUT THE WRITTEN PERMISSION OF QUINCY INDUSTRIES, INC. IS PROHIBITED.

UNLESS OTHERWISE SPECIFIED		DIMENSIONS ARE IN INCHES		TOLERANCES:		FINISH		MATERIAL		INTERPRET GEOMETRIC TOLERANCE PER	
NAME	DATE	DWN BY	KT	12-28-07	CHECKED	-	ENG APPR.	-	QA	-	COMMENTS
TITAN 10K, 15K, 20K SIZE DWG NO APPROVED: A WEIGHT N/A SHEET 1 OF 1											
USED ON APPLICATION NEXT ASSY.											

541 Industrial Way, Suite 1
Quincy
 Fallbrook, CA 92028
 Tel: (760) 723-5417
 Fax: (760) 728-5062

REV.	BY	DATE
A	KT	12-28-07

ADDED NEW TEMPLATE

R.O. 10000 SYSTEM

6	CHAMP 4" X 40" HOUSING PART# 200530	<A1>
6	THIN FILM COMPOSITE MEMBRANE (TFC) 4" X 40" (LP) PART# 200379	<A2>
12	END PLUG 4" PART# 200596	<A3>
12	SNAP RING 4" PART# 200597	<A4>
12	4" O-RING KIT PART# 200599	<A5>
2	0-300 P.S.I. PRESSURE GAUGE PART# 200904	
1	COMPUTER CONTROL S-150 PART# 200859(120 VAC)/200860(220VAC)	<C>
2	CONTROL VALVE / RECYCLE VALVE 1" SS PART# 200995	<D>
2	0-160 P.S.I. PRESSURE GAUGE PART# 200901	<E>
1	20" BIG GRAY PRE-FILTER HOUSING PART# 200731	<F>
1	5 MICRON SEDIMENT FILTER PART# 200650	<F1>
1	3 HP GOLIUS PUMP 110/220 VOLT PART# 200790	<G>
1	SOLENOID VALVE 110/220 VOLT PART# 200914(120VAC)/200915(220VAC)	<H>
1	LOW PRESSURE SWITCH PART# 200905	<I>
1	POWDER COATED EPOXY FRAME PART# N/A	<J>
3	RECYCLE FLOW METER 10 GPM PART# 200899	<K>
1	FILTER HOUSING FSI PART# 200739	<L>
1	18" FSI BAG FILTER 10MICRON PART# 200710	<M>
2	AUTO-FLUSH PART# 200042	<N>

R.O. 15000 SYSTEM

8	CHAMP 4" X 40" HOUSING PART# 200530	<A1>
8	THIN FILM COMPOSITE MEMBRANE (TFC) 4" X 40" (LP) PART# 200379	<A2>
16	END PLUG 4" PART# 200596	<A3>
16	SNAP RING 4" PART# 200597	<A4>
16	4" O-RING KIT PART# 200599	<A5>
2	0-300 P.S.I. PRESSURE GAUGE PART# 200904	
1	COMPUTER CONTROL S-150 PART# 200859(120 VAC)/200860(220VAC)	<C>
2	CONTROL VALVE / RECYCLE VALVE 1" SS PART# 200995	<D>
2	0-160 P.S.I. PRESSURE GAUGE PART# 200901	<E>
1	20" BIG GRAY PRE-FILTER HOUSING PART# 200731	<F>
1	5 MICRON SEDIMENT FILTER PART# 200650	<F1>
1	3 HP GOLIUS PUMP 110/220 VOLT PART# 200792	<G>
1	SOLENOID VALVE 110/220 VOLT PART# 200914(120VAC)/200915(220VAC)	<H>
1	LOW PRESSURE SWITCH PART# 200905	<I>
1	POWDER COATED EPOXY FRAME PART# N/A	<J>
2	FLOW METER 20 GPM PART# 200900	<K>
1	RECYCLE FLOW METER 10 GPM PART# 200899	<K1>
1	FILTER HOUSING FSI PART# 200739	<L>
1	18" FSI BAG FILTER 10MICRON PART# 200710	<M>
2	AUTO-FLUSH PART# 200042	<N>

R.O. 20000 SYSTEM

10	CHAMP 4" X 40" HOUSING PART# 200530	<A1>
10	THIN FILM COMPOSITE MEMBRANE (TFC) 4" X 40" (LP) PART# 200379	<A2>
20	END PLUG 4" PART# 200596	<A3>
20	SNAP RING 4" PART# 200597	<A4>
20	4" O-RING KIT PART# 200599	<A5>
2	0-300 P.S.I. PRESSURE GAUGE PART# 200904	
1	COMPUTER CONTROL S-150 PART# 200859(120 VAC)/200860(220VAC)	<C>
2	CONTROL VALVE / RECYCLE VALVE 1" SS PART# 200995	<D>
2	0-160 P.S.I. PRESSURE GAUGE PART# 200901	<E>
1	20" BIG GRAY PRE-FILTER HOUSING PART# 200731	<F>
1	5 MICRON SEDIMENT FILTER PART# 200650	<F1>
1	5 HP GRUNDFOUS PUMP 220/460 VOLT PART# N/A	<G>
1	SOLENOID VALVE 110/220 VOLT PART# 200914(120VAC)/200915(220VAC)	<H>
1	LOW PRESSURE SWITCH PART# 200905	<I>
1	POWDER COATED EPOXY FRAME PART# N/A	<J>
2	FLOW METER 20 GPM PART# 200900	<K>
1	RECYCLE FLOW METER 10 GPM PART# 200899	<K1>
1	FILTER HOUSING FSI PART# 200739	<L>
1	18" FSI BAG FILTER 10MICRON PART# 200710	<M>
2	AUTO-FLUSH PART# 200042	<N>

PROPRIETARY AND CONFIDENTIAL
THE INFORMATION CONTAINED IN THIS DRAWING IS THE SOLE PROPERTY OF BULKHEAD TECHNOLOGICAL COMPANY AND IS TO BE KEPT IN CONFIDENTIALITY. REPRODUCTION IN ANY MANNER WITHOUT THE WRITTEN PERMISSION OF BULKHEAD TECHNOLOGICAL COMPANY IS PROHIBITED.

UNLESS OTHERWISE SPECIFIED		DIMENSIONS ARE IN INCHES	
TOLERANCES:		FRACTIONAL ±	
DECIMAL ±		TWO PLACE DECIMAL ±	
THREE PLACE DECIMAL ±		INTERPRET GEOMETRIC TOLERANCE PER MATERIAL.	
FINISH:		DO NOT SCALE DRAWING	
NAME	DATE	DWN BY	KT
	12-28-07	CHECKED	-
		ENG APPR.	-
		QA	
COMMENTS		TITLE	
		TITAN 10K,15K,20K PARTS LIST	
SIZE	DWG NO	APPROVED:	REV
A			A
WEIGHT: N/A	SHEET 1 OF 1	541 Industrial Way, Suite 1 Fallsbrook, CA 92028 Tel: (760) 723-5417 Fax: (760) 728-5062	

TITAN 10K, 15K, 20K REVERSE OSMOSIS SYSTEMS

REVISIONS		REV.	DESCRIPTION	BY	DATE
A	ADDED NEW TEMPLATE	KT	12-28-07		
B	ADDED RECYCLE LOOP	KT	12-28-07		
C	ADDED FLUSH VALVE OPTION	KT	12-28-07		

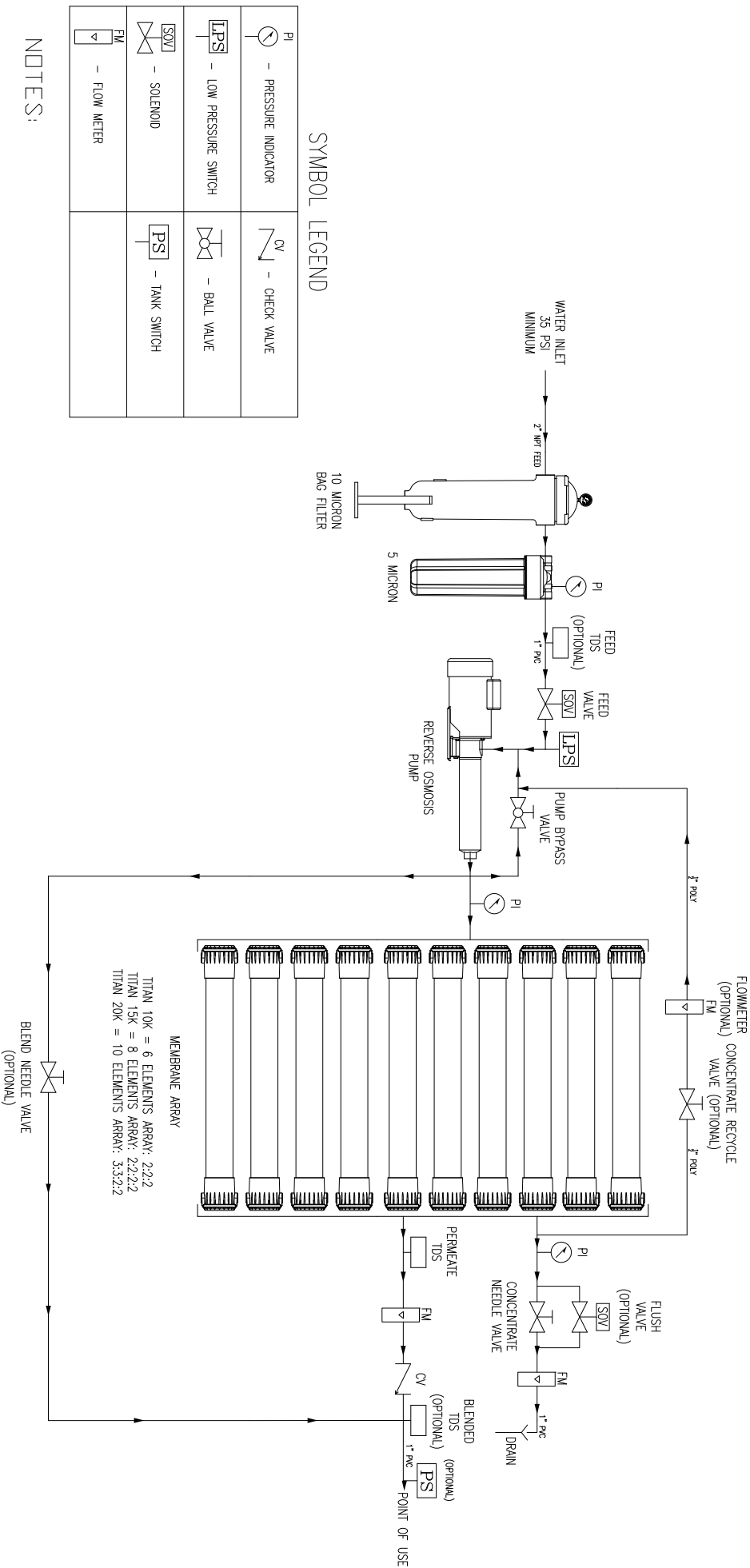

SYMBOL LEGEND

PI	- PRESSURE INDICATOR	CV	- CHECK VALVE
LPS	- LOW PRESSURE SWITCH	SOLENOID	- BALL VALVE
SOLENOID	- SOLENOID	PS	- TANK SWITCH
FM	- FLOW METER		

NOTES:

1. -
2. -
3. -
4. -
5. -
6. -
7. -

PROPRIETARY AND CONFIDENTIAL

THE INFORMATION CONTAINED IN THIS DRAWING IS THE SOLE PROPERTY OF BOURELLELAIN. ANY REPRODUCTION IN PART OR AS A WHOLE WITHOUT THE WRITTEN PERMISSION OF BOURELLELAIN IS PROHIBITED.

UNLESS OTHERWISE SPECIFIED		DIMENSIONS ARE IN INCHES		TOLERANCES:	
FRACTIONAL ±		ANGULAR MACH. ±		BEND ±	
TWO PLACE DECIMAL ±		THREE PLACE DECIMAL ±		INTERPRET GEOMETRIC TOLERANCE PER MATERIAL:	
FINISH:		COMMENTS		Q.A.	
NEXT ASSY.		USED ON		APPLICATION	
DD NOT SCALE DRAWING		NAME		DATE	
DD NOT SCALE DRAWING		DWN BY		KT	
DD NOT SCALE DRAWING		CHECKED		-	
DD NOT SCALE DRAWING		ENG APPR.		-	
DD NOT SCALE DRAWING		TITLE:		FLOW DIAGRAM	
DD NOT SCALE DRAWING		SIZE		DWG NO	
DD NOT SCALE DRAWING		APPROVED:		WEIGHT: N/A	
DD NOT SCALE DRAWING		SHEET 1 OF 1		REV C	

541 Industrial Way, Suite 1
 Fallbrook, CA 92028
 Tel: (760) 723-5417
 Fax: (760) 728-5062

REVISIONS			
REV.	DESCRIPTION	BY	DATE
A	DREW ELECTRICAL SCHEMATIC	KT	01-04-08

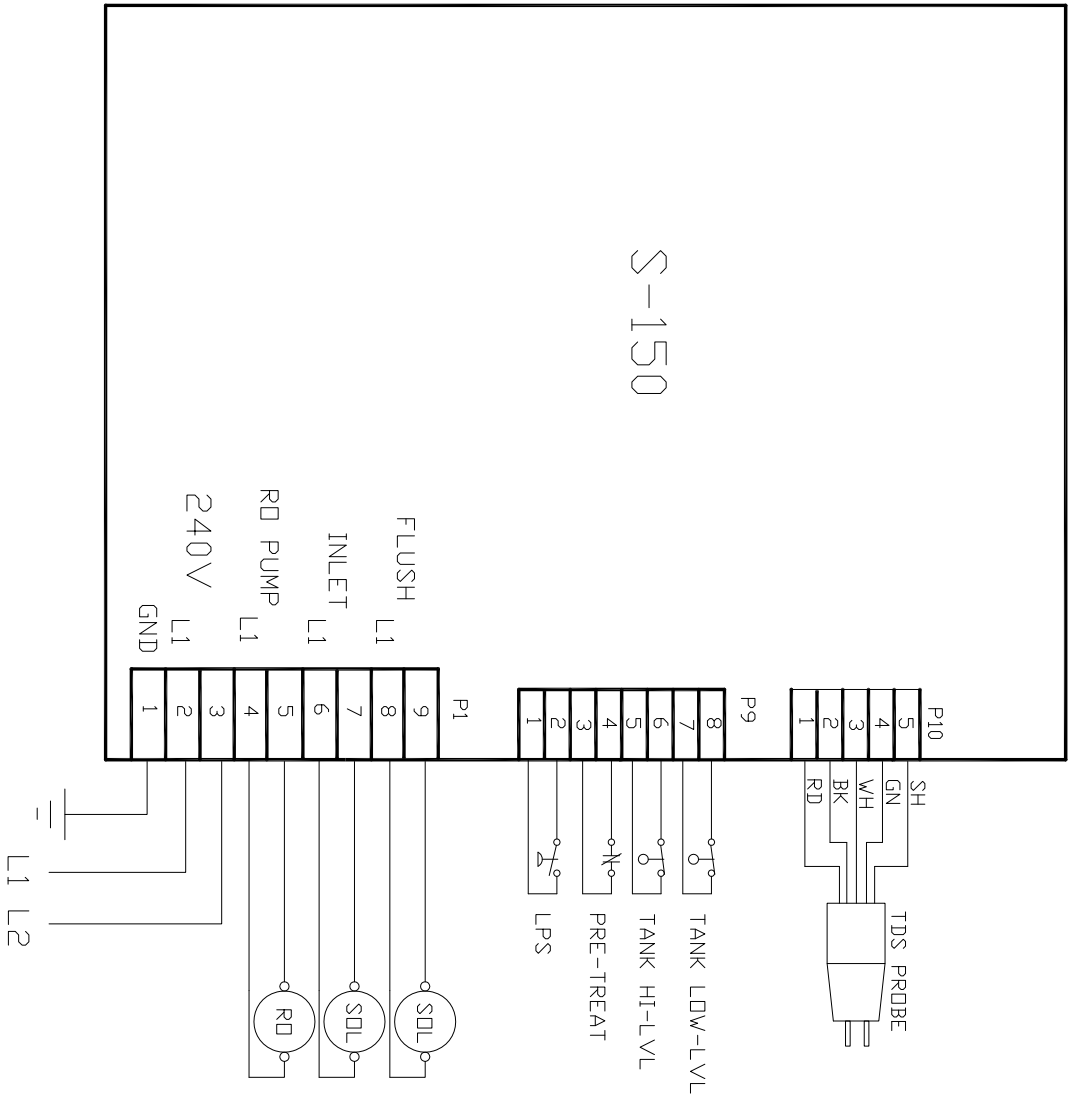

CAUTION!
DISCONNECT AND BRANCH
PROTECTION IS REQUIRED ON THE
POWER FEEDING THIS PANEL.

PROPRIETARY AND CONFIDENTIAL.
THE INFORMATION CONTAINED IN THIS
DRAWING IS THE PROPERTY OF
DREW ELECTRIC. ANY REUSE OR
DISSEMINATION OF THIS INFORMATION
WITHOUT THE WRITTEN PERMISSION OF
DREW ELECTRIC IS PROHIBITED.

UNLESS OTHERWISE SPECIFIED		DIMENSIONS ARE IN INCHES	
ANGULAR MATCH ±	BEND ±	DWN BY	NAME
THREE PLACE DECIMAL ±	TOLERANCE PER MATERIAL	KT	KT
TOLERANCE PER MATERIAL	FINISH	DATE	01-04-08
FINISH	DO NOT SCALE DRAWING	CHECKED	-
DO NOT SCALE DRAWING	DO NOT SCALE DRAWING	ENG APPR	-
DO NOT SCALE DRAWING	DO NOT SCALE DRAWING	QA	-
DO NOT SCALE DRAWING	DO NOT SCALE DRAWING	NOTES	-
DO NOT SCALE DRAWING	DO NOT SCALE DRAWING	SIZE	DWG NO
DO NOT SCALE DRAWING	DO NOT SCALE DRAWING	A	A
DO NOT SCALE DRAWING	DO NOT SCALE DRAWING	WEIGHT	N/A
DO NOT SCALE DRAWING	DO NOT SCALE DRAWING	SHEET	1 OF 1

DREW
ELECTRICAL 220VAC
1PH/60HZ

541 Industrial Way, Suite 1
Fallsbrook, CA 95028
Tel: (760) 753-5417
Fax: (760) 758-5082

REVISIONS			
REV.	DESCRIPTION	BY	DATE
A	ELECTRICAL SCHEMATIC	KT	01-04-08

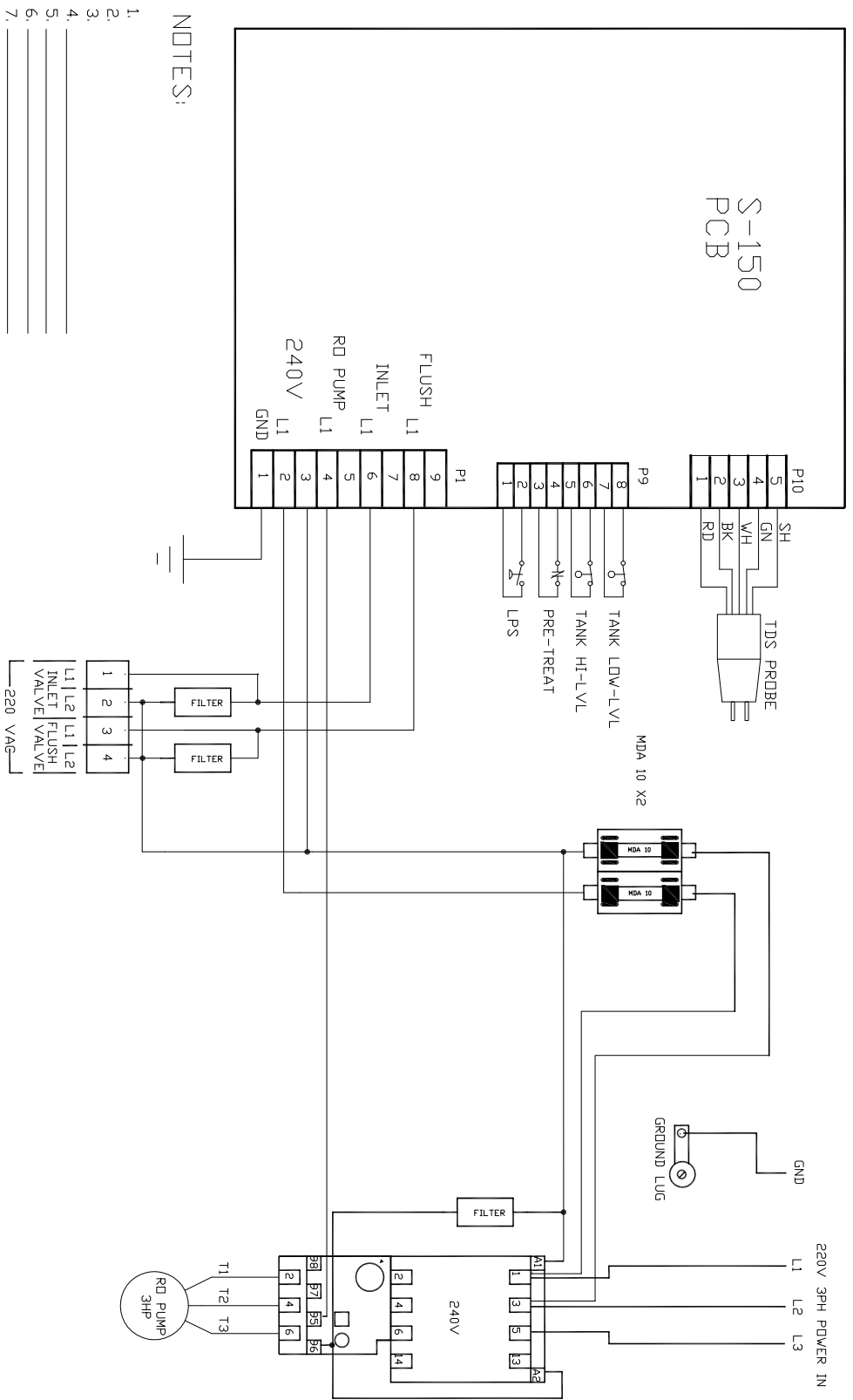

NOTES:

1. _____
2. _____
3. _____
4. _____
5. _____
6. _____
7. _____

CAUTION!
DISCONNECT AND BRANCH PROTECTION IS REQUIRED ON THE POWER FEEDING THIS PANEL.

PROPRIETARY AND CONFIDENTIAL
THE INFORMATION CONTAINED IN THIS DRAWING IS THE SOLE PROPERTY OF REPRESENT COMPANY. ANY REPRODUCTION IN PART OR AS A WHOLE WITHOUT THE WRITTEN PERMISSION OF REPRESENT COMPANY IS PROHIBITED.

UNLESS OTHERWISE SPECIFIED		NAME		DATE	
DIMENSIONS ARE IN INCHES		DWN BY		KT	
TOLERANCES:		CHECKED		-	
FRACTIONAL: +		ENG APPR:		-	
ANGULAR MACH: + BEND +		COMMENTS		Q.A.	
TWO PLACE DECIMAL +		INTERPRET GEOMETRIC TOLERANCE PER.		SIZE	
THREE PLACE DECIMAL +		MATERIAL:		DVG NO	
FINISH:		DO NOT SCALE DRAWING		REV	
TITLE:		APPROVED:		WEIGHT: N/A	
ELECTRICAL 220VAC		SHEET 1 OF 1		REV A	
3PH/50/60HZ					

PD
POURTRON
The Ultra Solution.
541 Industrial Way, Suite 1
Fallsbrook, CA 92028
Tel: (760) 723-5417
Fax: (760) 728-5062

REVIEWS		BY	DATE
REV.	DESCRIPTION		
	ELECTRICAL SCHEMATIC	KT	10-17-08

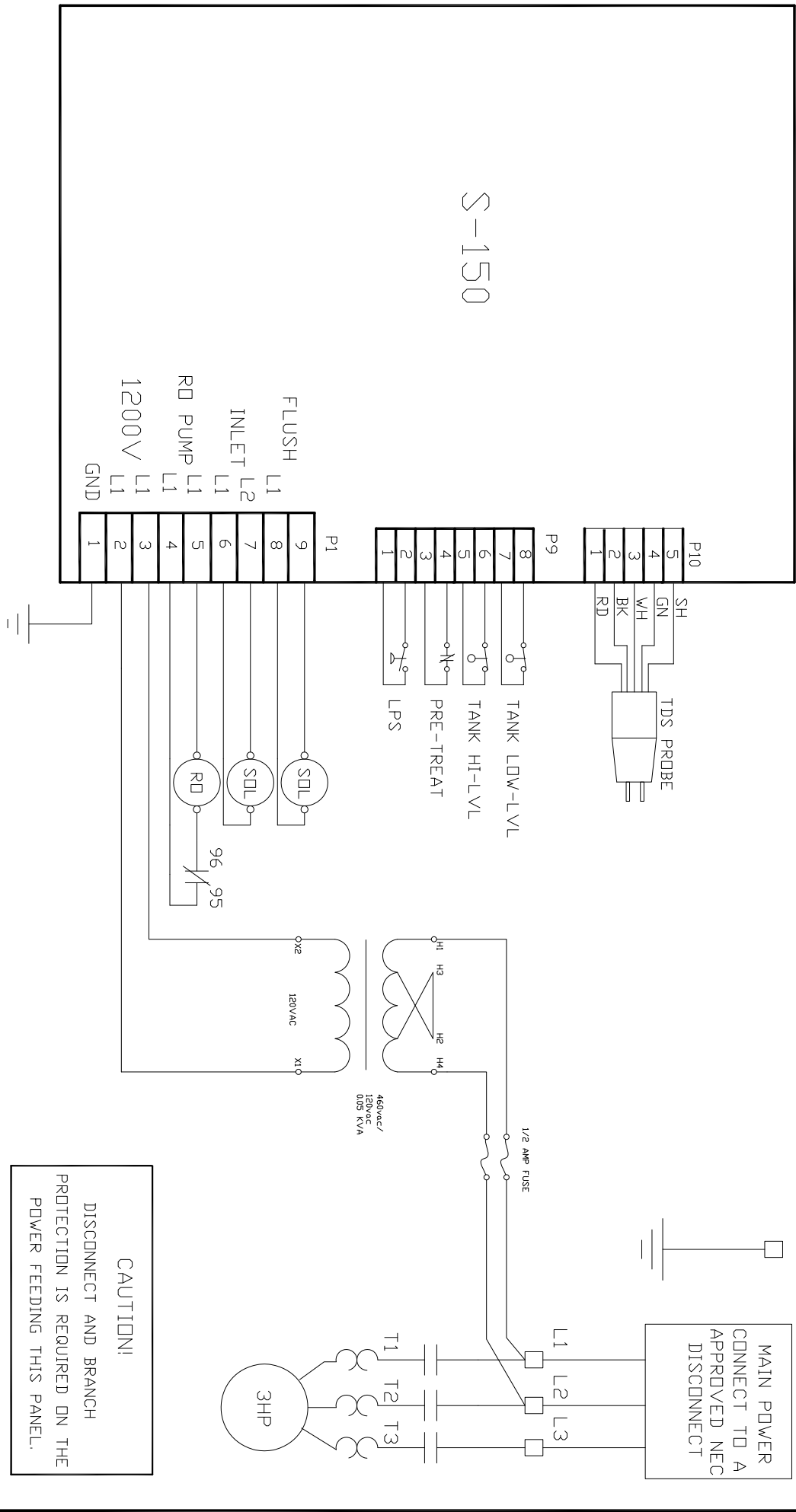

S-150

PROPRIETARY AND CONFIDENTIAL
 THIS AND ALL OTHER INFORMATION CONTAINED
 HEREIN IS THE PROPERTY OF L.P. WATERLOG
 AND IS TO BE KEPT SECRET AND NOT
 DISCLOSED TO ANY OTHER PARTY WITHOUT
 THE WRITTEN PERMISSION OF L.P. WATERLOG
 COMPANY. ANY REPRODUCTION OR
 TRANSMISSION IN ANY FORM OR BY ANY
 MEANS IS PROHIBITED.

UNLESS OTHERWISE SPECIFIED	NAME	DATE	SIZE	REV
DIMENSIONS ARE IN INCHES	DWN BY	10-17-08	DWG NO	A
TOLERANCES: FRACTIONAL ± THREE PLACE DECIMAL ±	CHECKED	-	WEIGHT N/A	A
TWO PLACE DECIMAL ± THREE PLACE DECIMAL ±	ENG APPR	-	SHEET 1 OF 1	
INTERPRET GEOMETRIC TOLERANCE PER MATERIAL	NOTES			
FINISH				
DO NOT SCALE DRAWING				
USED ON				
APPLICATION				
NEXT ASSY				

L.P. WATERLOG
 541 Industrial Way, Suite 1
 Fallbrook, CA 92028
 Tel: (760) 758-5842
 Fax: (760) 758-5842
 The Waterlog Group

TITLE: ELECTRICAL 460VAC
 3PH/60HZ