

ATTACHMENT 1
SURVEY DISK DIAGRAMS

TO
GENERAL GUIDANCE AND SPECIFICATIONS FOR
AERONAUTICAL SURVEYS VOLUME A

FEDERAL AVIATION ADMINISTRATION
AIRPORT SURVEYS

Survey Disk Diagrams

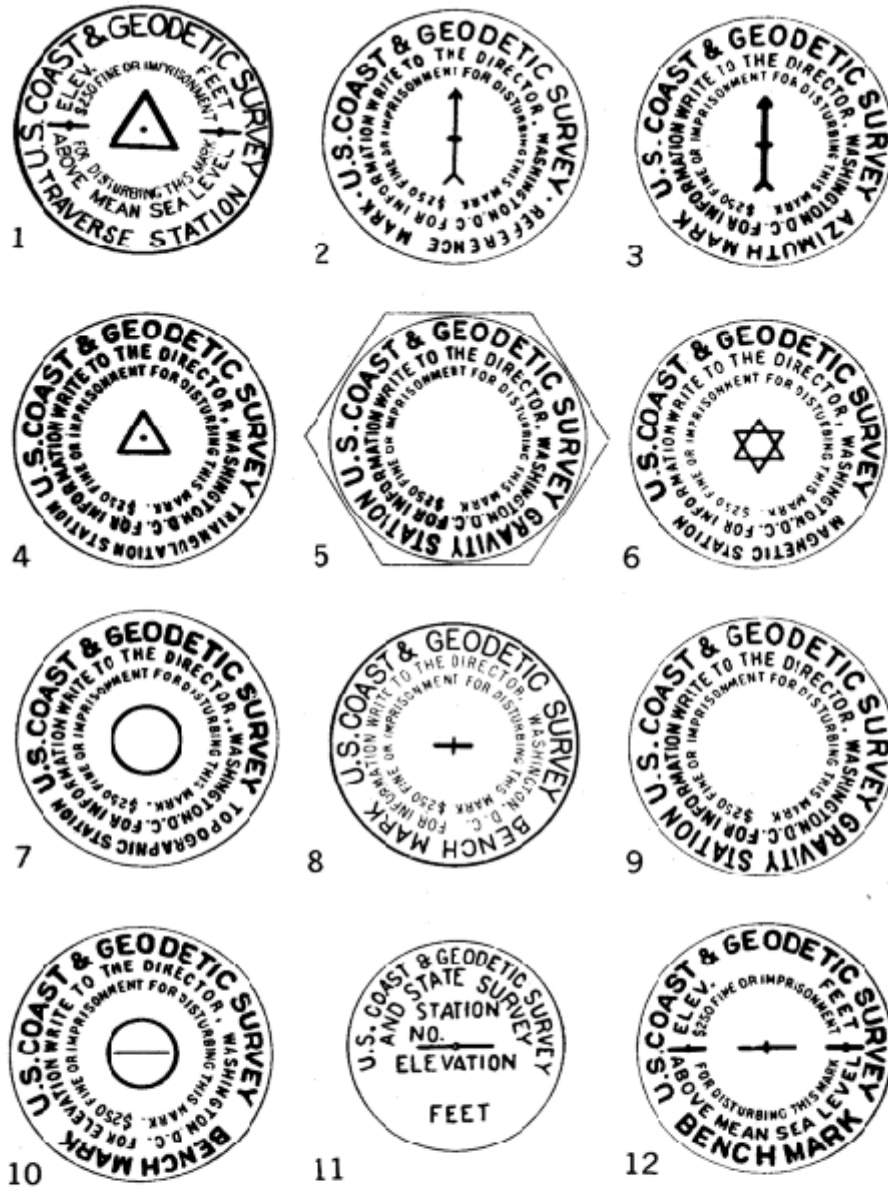

- | | | |
|---|--|--|
| <p>1. Traverse station mark.</p> <p>2. Reference mark.</p> <p>3. Azimuth mark.</p> <p>4. Triangulation station mark.</p> <p>5. Gravity station mark (old type).</p> | <p>6. Magnetic station mark.</p> <p>7. Topographic station mark.</p> <p>8. Geodetic bench mark (new type).</p> <p>9. Gravity station mark (new type).</p> <p>10. Tidal bench mark.</p> | <p>11. State Survey mark.</p> <p>12. Geodetic bench mark (old type).</p> |
|---|--|--|

Figure 3a.—Standard marks of the U.S. Coast and Geodetic Survey

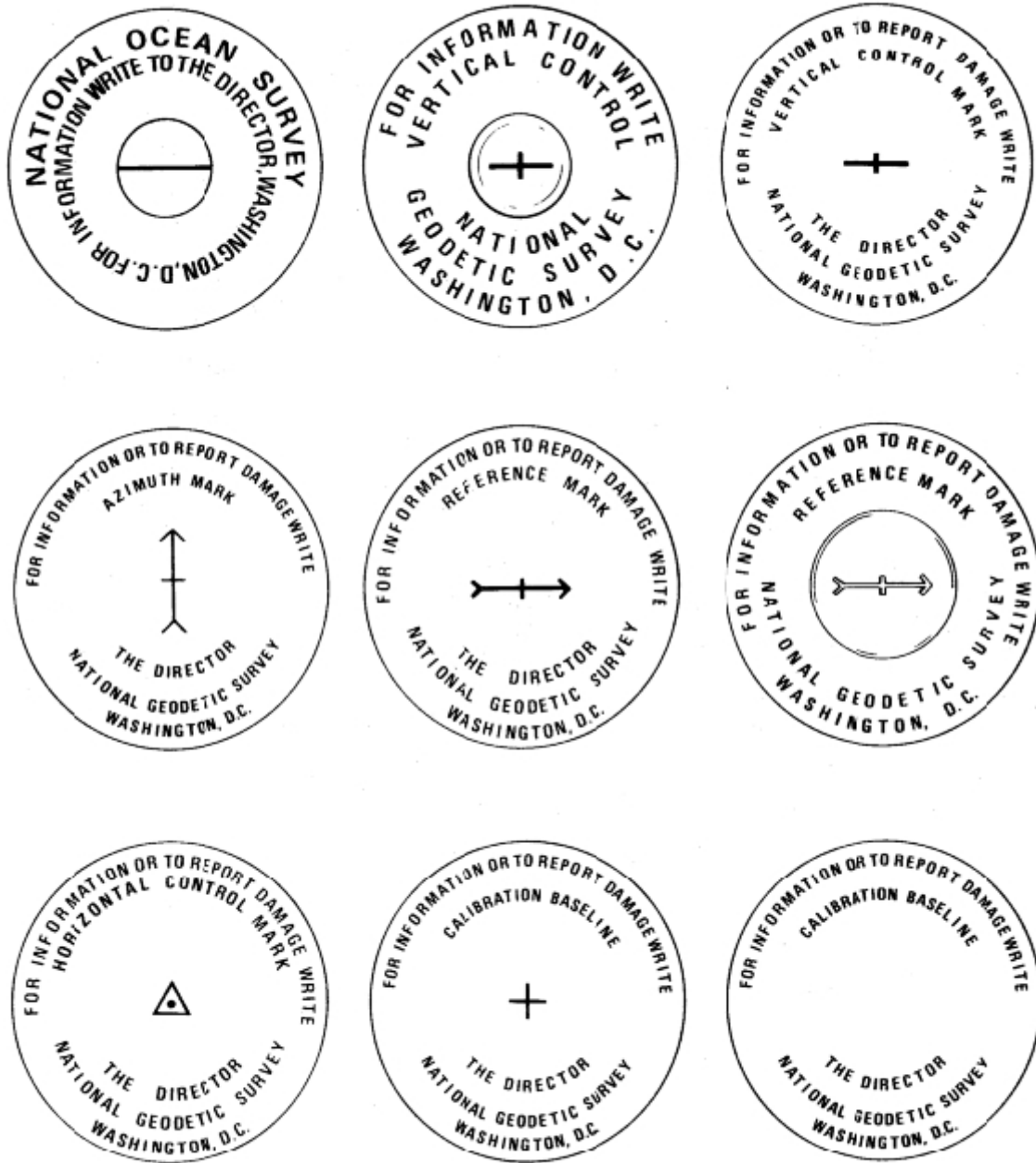
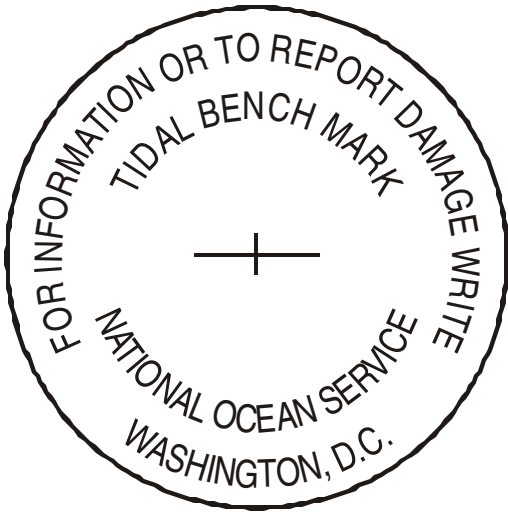

Figure 3b.—Standard marks of the National Ocean Survey/National Geodetic Survey



National Ocean Service
Tidal Bench Mark



National Ocean Service
General Usage Disk

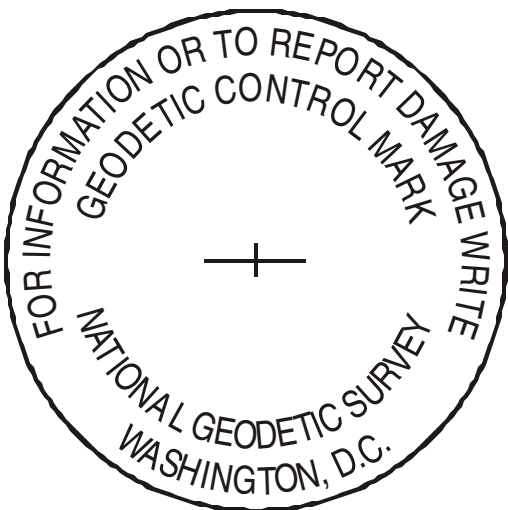

National Geodetic Survey
New Geodetic Control Disk

ATTACHMENT 2
SELECTION GUIDELINES FOR AIRPORT GEODETIC CONTROL SURVEYS

TO
GENERAL GUIDANCE AND SPECIFICATIONS FOR
AERONAUTICAL SURVEYS VOLUME A

FEDERAL AVIATION ADMINISTRATION
AIRPORT SURVEYS

ATTACHMENT 2

SELECTION GUIDELINES FOR AIRPORT GEODETIC CONTROL SURVEYS

Three permanent survey marks shall be established on, or within one km of, the airport. One of these marks shall be designated the Primary Airport Control Station (PACS). Horizontal and vertical datum ties shall be made directly between the PACS and the National Spatial Reference System (NSRS). The other two marks shall be designated Secondary Airport Control Stations (SACS). Horizontal and vertical connections shall be made directly between the SACS and the PACS.

Existing stations may be used as the PACS and SACS if they meet the accuracy, siting, construction, and other criteria identified in this attachment and the accuracy's in FAA No. 405, Standards for Appendix 5.

Proper monument site selection for PACS and SACS is a primary goal for these surveys and must be carefully considered. Factors to consider are monument stability, intervisibility requirements, visibility from the monuments to airport features such as runways, navigation aids, and airport obstructions off the end of runways, any previous high accuracy connection to the National Spatial Reference System (NSRS), accessibility, and survivability of the monuments.

The monuments must be accessible to survey crews, and allow for unattended, secure setup of GPS equipment for long periods without hindering airport operations. PACS and SACS must allow for setup of both conventional (optical) and satellite surveying equipment. If possible, SACS should be sited on high ground near the approach end of the primary runways so they can be better utilized for obstruction surveys. Monuments must be established in areas clear of future construction, and should be slightly recessed to protect them from snow removal and mowing equipment.

CONTROL STATION SELECTION PRIORITIES

PACS –

- 1) An existing mark may be used as a PACS if the mark meets the stability codes of A or B in that order of preference (see mark stability standards below).
- 2) An existing concrete mark with stability code C (and 4+ feet deep, belled bottom) may be used for a PACS if the disk: (1) already exists, (2) is poured in place concrete, (3) is a triangulation station, reference mark, azimuth mark, or bench mark stamped "U.S. Coast and Geodetic Survey", or any mark stamped "National Geodetic Survey", (4) is set below the frost line, (5) is set in nonexpansive soils, (6) shows no evidence of movement and (7) meets all siting, construction, and intervisibility requirements.

Note, an existing HARN station ("A" or "B" order station) does not necessarily qualify to be a PACS, it must still meet PACS stability and siting requirements.

SACS –

- 1) An existing mark may be used as a SACS if the mark meets the stability codes of A, B or C in that order of preference.

Note, other USC&GS, NGS, or NOS marks should be used as SACS if they meet all siting, construction, and intervisibility requirements.

CONTROL STATION SITING

The following are a list of considerations for every monument (new or old, control station or local network station) in the project. The intent is to ensure that stations will be stable and usable years after the survey is completed. Each of the considerations are important, and so, they are not prioritized.

- * Adequate GPS satellite visibility (unrestricted at 15 degrees above the horizon). Minor obstructions may be acceptable, but must be depicted on the Visibility Obstruction Diagram.
- * Accessible by vehicle (two-wheel drive preferred).
- * Stability, bedrock being most preferred. See below.
- * Permanency.
- * Ease of recovery.
- * Minimal multi-path.
- * Appropriate geographic location and spacing.
- * Location allows efficient use by surveying community.
- * Accessible by public. Public property should be utilized where feasible.
- * No known potential conflict with future development.
- * Aerial-photo identifiable.

PACS AND SACS PROXIMITY TO AIRPORT FEATURES

PACS shall be established in a secure area on airport property. A GPS suitable site should be selected where surveying equipment may be left unattended at the mark with a minimum probability of disturbance.

SACS should be established on airport property if practical. However, if the siting requirements, such as, intervisibility and spacing as described below, cannot be met, one SACS may be set off the airport but no further than 1 km from the nearest airport boundary.

If establishing the PACS and SACS requires new monumentation, the new monuments should be set no closer than 60 meters from a runway edge, or 60 meters from the imaginary runway extension.

If an existing control station is used, this station should be at least 15 meters from a runway edge. In all cases, PACS and/or SACS should be at least 400 meters apart.

PACS and SACS should be located so that a surveying tripod can be situated over the mark. In addition, if the mark could be in peril from snow removal, mowing, and other operations, it should be slightly recessed.

PACS and SACS should be strategically located so as to provide maximum use for subsequent surveys yet situated where the chances of future disturbance will be minimal. An elevated site with runway end visibility is desirable. PACS and SACS should also be located where future station occupation will cause no interference to or from aircraft, including from prop and jet blast. The sight path between stations over paved areas should be minimized.

PACS and/or SACS must not be within 305 meters (1000 ft) of the critical side of an:

- Instrument Landing System (ILS) Glideslope Antenna,
- Instrument Landing System (ILS) Localizer,
- Microwave Landing System Elevation Station,
- Microwave Landing System Azimuth Station.

PACS AND SACS INTERVISIBILITY

Intervisibility choices for PACS and SACS are:

FIRST CHOICE

The PACS and both SACS are all intervisible with each other.

SECOND CHOICE

The PACS is intervisible with both SACS but the SACS are not intervisible with each other.

THIRD CHOICE

The PACS is intervisible with one SACS and both SACS are intervisible with each other.

STABILITY

Stability codes A, B, and C are defined in the Blue Book, Volume 1, Annex I, with examples given below. Only codes A and B are recommended, however concrete posts may be selected with code C

stability if the mark is deemed stable from review of soil conditions and average frost depth.

Stability code A = expected to hold an elevation. Examples: rock outcrops; rock ledges; bedrock; massive structures with deep foundations; large structures with foundations on bedrock; or sleeved deep settings (10 feet or more) with galvanized steel pipe, galvanized steel, stainless steel, or aluminum rods.

Stability code B = probably hold an elevation. Examples: unsleeved deep settings; massive retaining walls; abutments and piers of large bridges or tunnels; unspecified rods or pipe in a sleeve less than 10 feet; or sleeved copper-clad steel rods.

Stability code C = may hold an elevation but subject to ground movement. Examples: Metal rods with base plates less than 10 feet deep; concrete posts (3 feet or more deep); large boulders; retaining walls for culverts or small bridges; footings or foundation walls of small to medium-size structures; or foundations such as landings, platforms, or steps.

MINIMUM ACCURACY REQUIREMENTS FOR PACS/SACS

The required accuracy standards for PACS and SACS are listed below and are contained in FAA Number 405, “Standards for Aeronautical Surveys and Related Products”, Fourth Edition, Appendix 5.

ITEM	HORZ	VERTICAL	
		ORTHO	ELLIP
PRIMARY AIRPORT CONTROL STATION (PACS) ¹	5	25	15
SECONDARY AIRPORT CONTROL STATION (SACS) ²	3	5	4
WIDE AREA AUGMENTATION SYSTEM (WAAS) REFERENCE STATION ¹	5	10	10
WIDE AREA AUGMENTATION SYSTEM (WAAS) REFERENCE STATION ³	1	0.2	2
¹ ACCURACIES ARE RELATIVE TO THE NEAREST NATIONAL GEODETIC SURVEY SANCTIONED CONTINUOUSLY OPERATING REFERENCE STATION			
² ACCURACIES ARE RELATIVE TO THE PACS AND OTHER SACS AT THE AIRPORT			
³ ACCURACIES ARE RELATIVE TO THE OTHER WAAS REFERENCE STATION AT THE SITE			

Version 12
July 15, 2003

ATTACHMENT 3
REQUIREMENTS FOR DIGITAL PHOTOGRAPHS
OF SURVEY CONTROL

TO
GENERAL GUIDANCE AND SPECIFICATIONS FOR
AERONAUTICAL SURVEYS VOLUME A

FEDERAL AVIATION ADMINISTRATION
AIRPORT SURVEYS

ATTACHMENT 3 - REQUIREMENTS FOR DIGITAL PHOTOGRAPHS
OF SURVEY CONTROL

I. PURPOSE.....	3
II. SURVEY MARKS.....	3
II.A. NUMBER OF PHOTOGRAPHS.....	3
II.B. CAPTION.....	4
II.C DESCRIPTION OF PHOTOGRAPHS.....	4
1. CLOSE-UP.....	4
2. EYE-LEVEL.....	5
3. HORIZONTAL VIEW(S).....	5
III. RECONNAISSANCE.....	6
III.A. PROPOSED LOCATIONS FOR MARKS.....	6
III.B. RUNWAY END PHOTOGRAPHS.....	6
III.C. NAVIGATION AIDS.....	6
III.D. DEPTH OF HOLE PHOTOGRAPHS.....	6
III.E. PHOTOGRAMMETRIC CONTROL POINTS.....	6
III.F. OTHER REQUIRED PHOTOGRAPHS.....	7
IV. GENERAL.....	7
IV.A. IMAGE SIZE.....	7
IV.B. FILE SIZE.....	7
IV.C. IMAGE FORMAT.....	7
IV.D. PHOTOGRAPH FILE NAME.....	7
V. STORAGE MEDIUM.....	7
*ACRONYMS.....	7

ATTACHMENT 3 - REQUIREMENTS FOR DIGITAL PHOTOGRAPHS OF SURVEY CONTROL

I. PURPOSE - This document describes digital photographic standards for images of survey marks that will be stored in the National Geodetic Survey (NGS) database and for other reconnaissance photographs. Since many of these images will be in the NGS database and available to the public, the subject matter (survey equipment, personnel, background, etc.) must be in good taste and professional in nature.

Digital photographs are useful for station (mark) reconnaissance, mark recovery, mark stability assessment, quality control, and as an aid during data processing and data verification. Some projects may require digital photographs during several stages of the project. Generally three photographs per station will be stored in the NGS database, which will make them accessible to future users. The table below summarizes the required photographs. Detailed descriptions of the photographs follow.

II. SURVEY MARK PHOTOGRAPHS - Take all photographs during daylight hours.

II A. NUMBER OF PHOTOGRAPHS - At least three digital photographs are required for each mark recovered or described during the current project. This means marks for which a written, NGS format, digital description or recovery note was prepared. The three photographs are described as numbers: (1) extreme close-up, (2) eye-level (5-6 feet distant), and (3) horizontal view (approx. 10-30 feet distant). All three photographs require a digital caption and the correct file name. Photographs 2 and 3 require a **small, temporary sign** in the photograph.

REQUIRED PHOTOGRAPHS

<u>All Marks Recovered and/or Described</u>
1. Close-up (Taken Vertically)
2. Eye level (Taken Vertically)
3. Horizontal view(s), mark in foreground

Take sufficient photographs to describe the stamping, appearance, condition, and location of the mark and points of potential interest including visibility obstructions, roads, runways, taxiways, or other dangers, any special set-up requirements, etc. Alter the orientation of the photographs as necessary to include this information in as few photographs as possible (For example, for a tall obstruction, rotate the camera 90 degrees so that the long axis of the image is vertical). Capture the tops of nearby obstructions, if possible. If a station already has acceptable photographs in the NGS database, additional photographs are not required, unless changes have occurred or more than one year has passed. An “acceptable photograph” is defined as an image that meets the requirements of this

document, is of good visual quality, and that no changes have taken place that a new photograph would help clarify.

II B. CAPTION - The photographer shall write a caption for each photograph. The caption should contain the following comma-separated information:

- Station designation (name),
- Station Permanent IDentifier (PID), for existing stations in the NGS database, leave blank if new station,
- Airport Location IDentifier (LID), if on airport, leave blank if not on airport,
- Photo number with cardinal direction (N, NE, E, SE, etc) that the camera is pointing, only photo #3 has a direction
- Station type (i.e. PACS, SACS, FBN, CBN), otherwise leave blank
- Date photo was taken (ddMMMyyyy).

SAMPLE CAPTION FOR NEW MARK

JONES, 2, 8JAN2001

SAMPLE CAPTION FOR EXISTING PACS ON AIRPORT

SMITH, AB1234, LAX, 3N, PACS, 8JAN2001

Note, the cardinal direction should not be included on photographs 1 and 2 since they were taken vertically.

The caption may be digitally captured on the image at the time of exposure or may be inserted later, off-line. Record at least the date on-line, if possible. If caption information is added later, take careful notes at the time of exposure to help ensure that the correct caption is added. **Note, the caption shall not obstruct any pertinent aspects of the station or surroundings.** To ensure that the letters of the caption are visible, use software to “erase” a rectangular area for the caption’s lettering; see samples below.

II C. DESCRIPTION OF PHOTOGRAPHS:

1. CLOSE-UP - For survey marks, the first photograph (photo no.1) will be a close-up, taken vertically. It will be oriented downward to show the survey mark from directly above with the disk or logo cap nearly filling the image. Brush any dirt or debris off the mark to show the disk. If it has a logo cap, the logo cap should be open. The intent of this photograph is to clearly show the condition of the mark and all



stamping on the mark or logo cap so that it is clearly legible. Use extra care to ensure that the stamping is clear. Suggestions: set the camera to its highest quality and resolution modes; **rub a yellow crayon across the stamping to highlight the letters**; set the camera to “macro” mode, if available; consider the minimum focusing distance of the camera (take test photographs to determine the minimum focusing distance and consult the camera owner’s manual) ; and, if a flash is used, hold the camera above and off to the side so that the flash does not create a bright spot in the middle of the disk’s image. Note, medium quality and resolution camera modes may be used for photographs other than the close-ups. If additional photographs are required, number these close-ups as 1A, 1B...

2. EYE-LEVEL - For survey marks, this photograph (photo no.2) will be oriented vertically downward from eye level to show the monument from directly above and cover an area about 1 meter in diameter. Brush any dirt or debris off the mark to show the disk and the setting. If it is a concrete monument, clear off debris to the edge of the monument. If it has a logo cap, the logo cap should be open. **Include a small, temporary sign in this photograph with the station designation (name) printed so it is clearly visible in the photograph.** The intent of this photograph is to show the general condition of the mark and the immediate surrounding area. If additional photographs are required, number these eye-level photos as 2A, 2B...



3. HORIZONTAL VIEW(S) - For survey marks, take at least one additional, daylight photograph oriented near horizontal, and show the mark, with tripod and antenna (if possible), in the foreground, and its identifying surroundings and any significant obstructions or possible sources of multi-path in the background. Show the top of nearby obstructions, if possible. Consider rotating the camera 90 degrees to use the long axis of the image to capture an entire obstruction. **Place a temporary sign in this photograph with the station designation (name) and the direction the camera is pointing, both printed so they are clearly visible in the photograph.** If additional photographs are taken, ideally move around the mark to locations which are 90 degrees apart (preferably cardinal directions). Name these photographs number 3XX, where the “XX” is the cardinal direction the camera is pointing, for example, 3N or 3NE.



II D. FILE NAMES - See Section IV D.

III. RECONNAISSANCE PHOTOGRAPHS - Some or all of the digital images described in this section may be required on a given project; refer to the Project Instructions. Each of these photographs requires a sign, a caption, and the correct file name. The names for all of these files shall begin with “RE” to indicate reconnaissance.

<u>Required Item</u>	<u>Contents</u>	<u>Description</u>
Sign in Photo	Name & Direction (unless vertical photo)	Place a sign in this photograph with the station designation (name) and the direction the camera is pointing, both printed so they are clearly visible in the photograph.
Digital Caption	Name, PID, LID, Number, Type, Date	See Section II.B above
Photo File Name	RE-Name-PID-Number-Date.jpg	See Section IV.D below

All of the images required by this section shall be designated as reconnaissance (recon) with the letters “RE” at the beginning of their file names. Generally these recon images will not be loaded in the NGS data base but may be required for use during planning, review, etc. All reconnaissance photographs will have digital captions. These captions may be captured on the image or added later. Note, in these specifications, “**RE**” stands for “**reconnaissance**” and “R” stands for “right” runway.

See the Project Instructions to determine which of the following are required:

III. A. PROPOSED LOCATIONS FOR MARKS - Take two photographs of each proposed permanent mark location. These may be one photo number 2 and one number 3, or two number 3 (3A and 3B), depending on which combination better shows the proposed mark location. Include a tripod, stake, sign, or other device showing the proposed mark location.

III. B. RUNWAY END PHOTOGRAPHS - Take at least three photographs at the end of each runway (including thresholds and stopways) surveyed in the current project, as follows:

- Eye-Level (photo type #1) - photo from directly above the mark, showing about 1 meter in diameter,
- Approach (photo type #3) - photo showing tripod over mark in foreground and approach in background
- Across runway (photo type #3) - photo taken from the side of the runway looking across the end of the runway, with a tripod or arrow indicating the end point; include any features used to identify the runway end.

III. C. NAVIGATION AIDS (NAVAIDS) - Take photo(s) (type #3) of all NAVAIDS surveyed. Show the survey tripod in place to indicate the exact point surveyed, or if positioned remotely, add arrows and labels to the photograph indicating the horizontal and/or vertical point(s) surveyed.

III. D. DEPTH OF HOLE PHOTOGRAPHS - Take at least one photograph showing the hole dug or drilled for a concrete or rod mark. Place a measuring device (e.g., tape measure or level rod) in the hole, clearly showing the depth of the hole.

III.E. PHOTOGRAMMETRIC CONTROL POINTS (Paneled and photo identified) - Take two number 3 type photographs of all photogrammetric control points clearly showing the point. These photos will be used later as an aid in identifying the point on the aerial photographs. Show the mark in the foreground and the nearest identifiable feature in the background. The two photographs should be taken from two different directions, ideally 90 degrees apart (such as from the East and the South).

III.F. OTHER REQUIRED PHOTOGRAPHS - as may be required by other instructions.

IV. GENERAL:

IV A. IMAGE SIZE - Each image should be about 800 by 1000 pixels when submitted.

IV B. 2. FILE SIZE - Maximum file size for each image is 500 KB, typical file size should be about 50 - 100KB.

IV C. IMAGE FORMAT - Store the digital photographs in JPEG format, approximately 50% reduction.

IV D. PHOTOGRAPH FILE NAME - Use the following file naming convention: the optional “RE” (for reconnaissance), dash, the station designator, dash, the PID, dash, the photo number (1, 1A, 2, 3N, or 3NE, etc.), dash, date, dot, jpg. For new marks, there is no PID. Use a maximum of 30 alpha-numeric characters to the left of the dot.

Sample File Names

For new stations:	SMITH-3-date.jpg
For existing stations:	SMITH-AB1234-1-date.jpg
For recon photos:	RE-SMITH-AB1234-3-date.jpg
For runway end point:	RE-LAX_CL_END_RWY_12R-3-date.jpg

For the runway end point example, “RE” = reconnaissance, dash, LAX = LID, dash, “CL END RWY 12R” = runway end point designator (CL = centerline, END = end, RWY = runway, 12 = runway number, and R = right (or C = center, or L = left), dash, “2” = photo number, and date. Note, “_” (underscores) used to fill blanks. Note, in these specifications, “RE” stands for

“reconnaissance” and “R” stands for “right” runway (used if there is a parallel set of runways). Also, the LID may be four characters rather than just three.

V. STORAGE MEDIUM - Submit all digital photos together on their own medium (CD), **not on the same medium with other types of data**. For airport work, submit all photos for a given airport in a subdirectory named for that airport.

*Aconyms:

PACS - Primary Airport Control Station

SACS - Secondary Airport Control Station

FBN - Federal Base Network

CORS - Continuously Operating Reference Station (Global Positioning System receiver)

CBN - Cooperative Base Network

RM - Reference Mark

ATTACHMENT 4
STATION LOCATION SKETCH AND
VISIBILITY DIAGRAM

TO
GENERAL GUIDANCE AND SPECIFICATIONS FOR
AERONAUTICAL SURVEYS VOLUME A

FEDERAL AVIATION ADMINISTRATION
AIRPORT SURVEYS

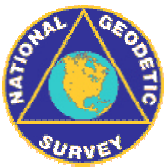

Attachment 4

Station Location Sketch and Visibility Diagram

Location / Airport Name and ID _____ Project _____

Station Designation _____ PID _____ Date _____

Circle all applicable: PACS SACS BM FBN CBN OTHER _____ Observer & Organization _____

Station Location Sketch

Blank area for Station Location Sketch

Sketch of Disk

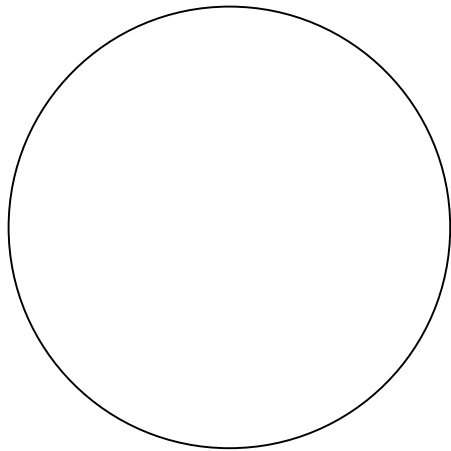

Visibility Diagram

No Obstructions

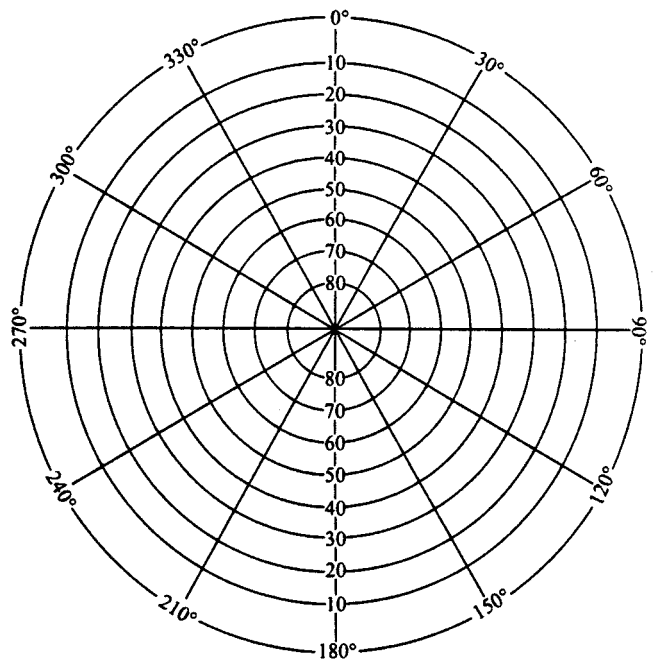



Station Recovery Log

Station #: MMK C (MMK, CT.)
 Project Name: A/E ANA (SURVEY)
 Job Number: 5733B
 Local Date: 18 DEC. 99
 Name: BJM

TO-REACH DIRECTIONS

FROM TERM. LATTE, GO W. 0.05 mi
 TO TWY, TURN LEFT & GO S.
0.60 mi ON TWY TO END & STA.
 ON THE LEFT.

4" x 12" ϕ CONC. MON.

STATION LOCATION

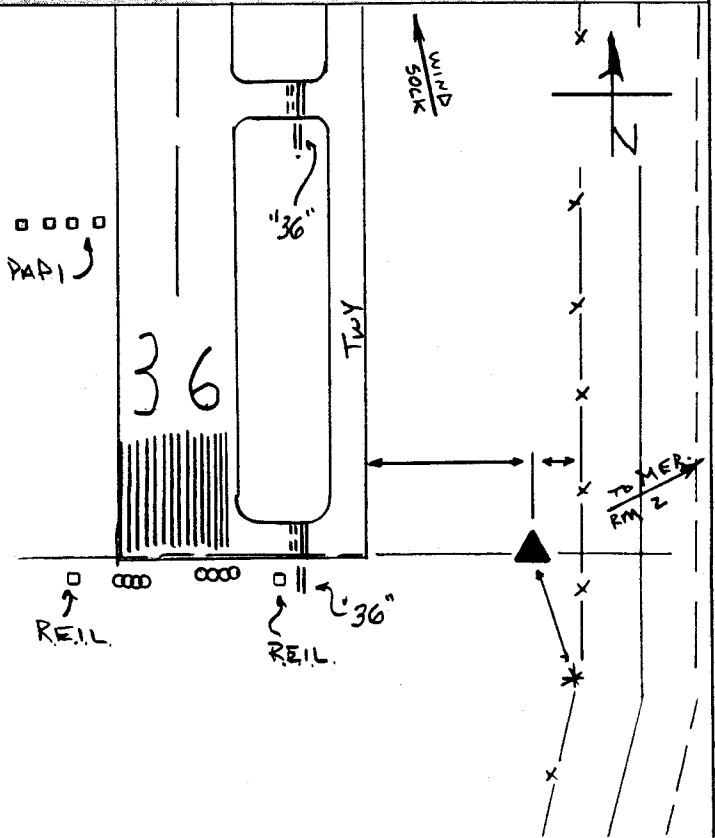

REFERENCES

Reference Object	Distance	Azimuth
E.O.P. w/ TWY	62.94	E
CLF. LINE	6.10	W
BEND IN FL @ FENCE POST	37.23	340°

VISIBILITY DIAGRAM

No Obstructions

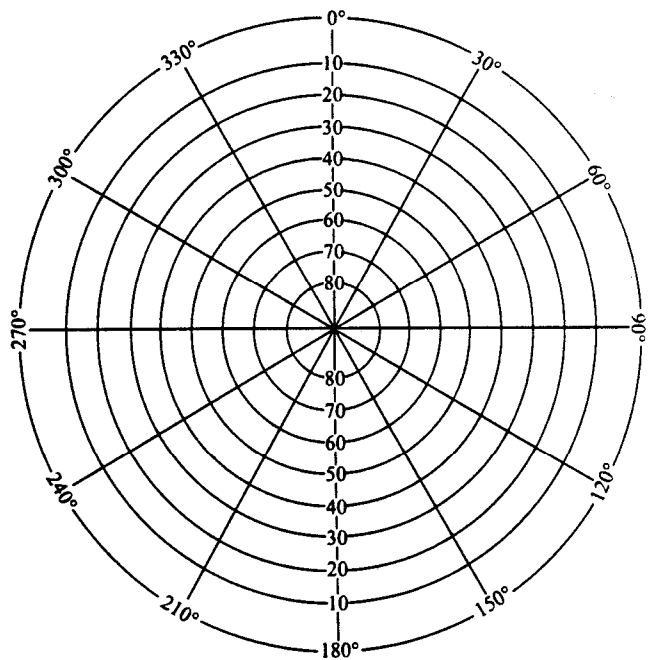

DISC DETAIL

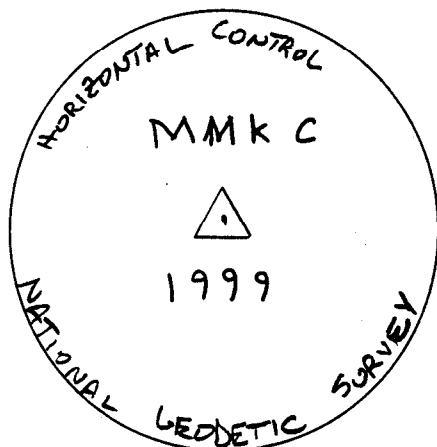

SET 08/NOV 99



Station Recovery Log

Station #: SB3 A *Proposed PACS*
 Project Name: NE ANA SURVEY (SB3)
 Job Number: 57738
 Local Date: 15-DEC-99
 Name: EJR

TO-REACH DIRECTIONS

FROM TERMINAL: 100' WEST TO RUNWAY 31; CROSS RUNWAY 31 & TURN RIGHT (NW) GO 0.15 MILE ALONG GRASS STRIP TO STATION ON LEFT.

STATION LOCATION

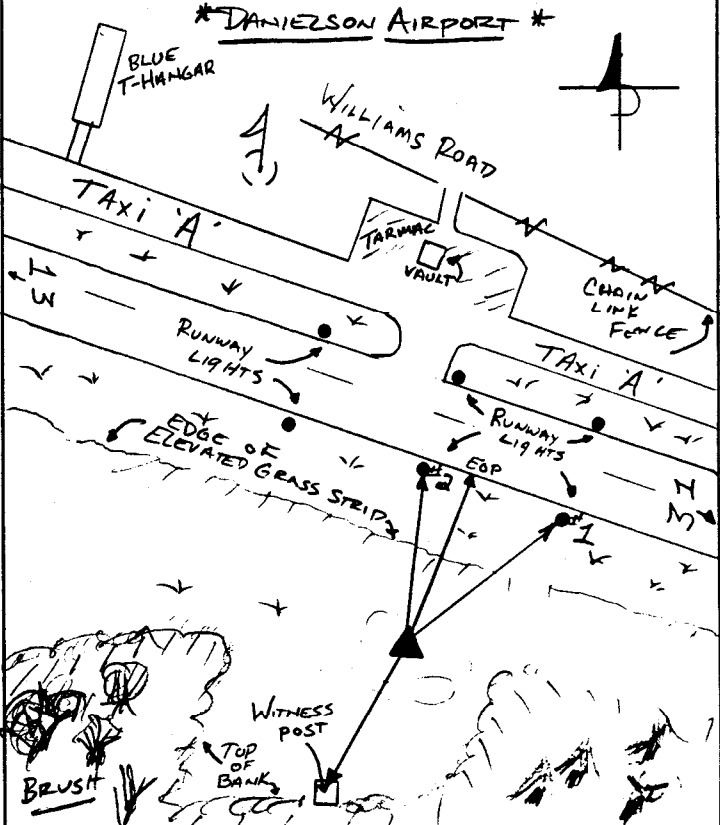

REFERENCES

Reference Object	Distance (m)	Azimuth
RUNWAY LIGHT #1 [TAG #25]	59.651	250°
RUNWAY LIGHT #2	65.843	192°
WITNESS POST	24.782	58°
EDGE PAVEMENT RUNWAY 13-31	58.190	225°

VISIBILITY DIAGRAM

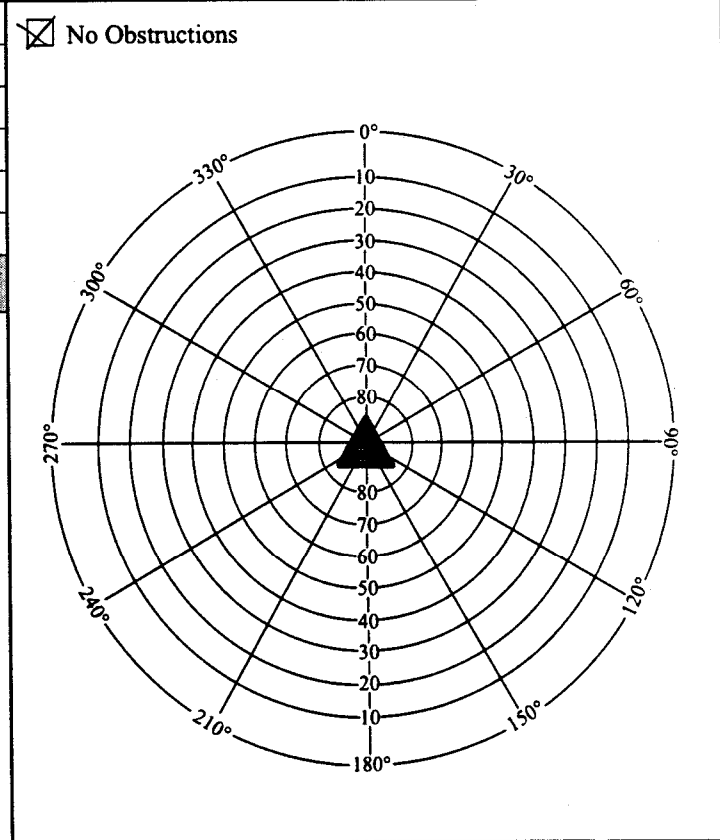

DISC DETAIL

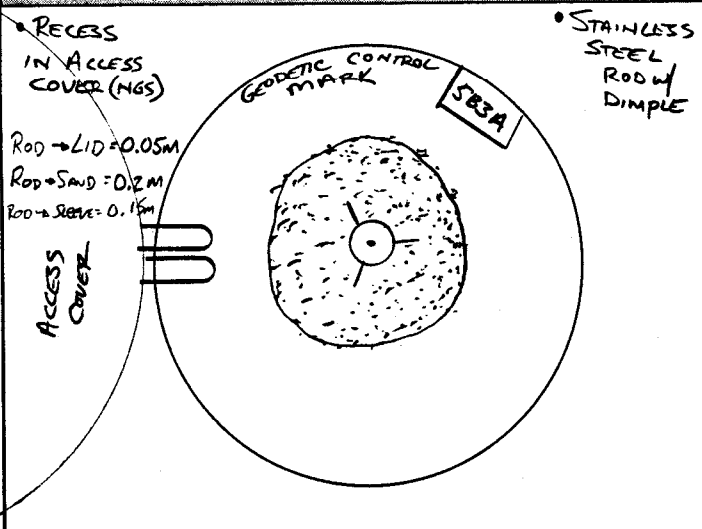

December 11, 2003

ATTACHMENT 5
WRITING STATION DESCRIPTIONS AND RECOVERY
NOTES WITH WDDPROC

TO
GENERAL GUIDANCE AND SPECIFICATIONS FOR
AERONAUTICAL SURVEYS VOLUME A

FEDERAL AVIATION ADMINISTRATION
AIRPORT SURVEYS

WRITING STATION DESCRIPTIONS AND RECOVERY NOTES WITH WDDPROC

Descriptions are one of the end products of surveying, along with the positions and the survey marks themselves. All three shall be of highest quality. The descriptions must be complete, accurate and in standardized format if the station is to be reliably and easily recovered for use in the future. Descriptions shall be in the standard NGS format of three paragraphs as described below under "Description Format."

1.0 GENERAL

1.1 DEFINITION OF DESCRIPTION VS. RECOVERY NOTE

- a. A *description* details the location of a new survey mark, or one not previously in the NGS digital database.
- b. A *recovery note* is an update and/or refinement to a description already in the NGS digital database, written upon a return visit to a survey mark.

1.2 LEVELS OF COMPLEXITY OF RECOVERY NOTES

- a. No Changes - If an existing station's digital description is complete, accurate, and meets Blue Book requirements, the station may be recovered with a brief recovery note, such as "RECOVERED AS DESCRIBED."
- b. Minor Changes - If minor changes or additions to the description are required, they may be added after the above phrase, such as "RECOVERED AS DESCRIBED, EXCEPT A NEW WOODEN FENCE IS NOW 3 METERS NORTH OF THE STATION." See typical cases listed below.
- c. Major Changes - Where major changes have occurred, major inaccuracies are found, or where required information is missing (in any portion of the description), a complete three-paragraph recovery note, with the same format as a new description, is required. If a measurement discrepancy is found, state that the new distance was verified, for example, by taping in both English units and metric units or by two separate measurements by two different people. See typical cases listed below.
- d. Exemption - If a recovery note has been written for the station within one year and no changes have taken place, a new recovery note is not required. Note, this may cause an error message in the description checking software, which may be ignored.

1.3 SOFTWARE - Descriptions and Recovery notes must be properly encoded into a D-file by using NGS WDDPROC software. Please refer to the NGS Web site:

<http://www.ngs.noaa.gov/FGCS/BlueBook/>, Annex P (Geodetic Control Descriptive Data), for information. Note, WDDPROC is used for both new Descriptions and for Recovery Notes.

1.4 CHECKING - Descriptions shall be written by one person and checked by another. Recovery notes should also be checked. For example, a mark setter can draft a description immediately after setting the mark, and an observer can check the description during observations. For existing marks, the reconnaissance person can draft the recovery note and the observer can check it. Descriptions and Recovery Notes should be written while at the station or immediately after visiting a station so that all details are fresh in the writer's mind.

1.5 TYPICAL RECOVERY NOTE CASES

- a. A brief, one or two sentence Recovery Note is adequate:
 - i. When the mark is found and the description is completely accurate, sample: ("RECOVERED AS DESCRIBED"),
 - ii. When the mark is found and there are one or two minor changes, ("RECOVERED AS DESCRIBED EXCEPT A NEW WOODEN FENCE IS NOW 3 METERS NORTH OF THE STATION"),
 - iii. When the mark is not found, ("MARK NOT FOUND AFTER 3 PERSON-HOUR SEARCH"),
 - iv. When the mark is not found and presumed destroyed, (" MARK NOT FOUND AND PRESUMED DESTROYED. CONSTRUCTION FOREMAN STATES THAT THE MARK WAS DESTROYED YESTERDAY"),
 - v. When the mark is found destroyed, (" THE MARK IS DESTROYED AND THE DISK HAS BEEN SENT TO NGS" or "THE MARK IS DESTROYED AND ITS PHOTOGRAPH HAS BEEN SENT TO NGS"). Note, for a station to be considered destroyed by NGS, the disk or photograph showing the destroyed mark must be received by NGS.

- b. A complete, new, three-paragraph Description/Recovery Note is required:
 - i. When a new mark is set,
 - ii. When an existing mark does not have a PID,
 - iii. When an existing mark does not have an NSRS digital description (i.e., description is not in NGS database),
 - iv. When an existing mark has only a brief description not meeting the three-paragraph requirement (many bench marks have only short, one-paragraph descriptions),
 - v. When an existing mark's description is no longer accurate or complete.

2.0 DESCRIPTION FORMAT

The original USC&GS Special Publication No. 247, MANUAL OF GEODETIC TRIANGULATION, page 116, states, "A description must be clear, concise, and complete. It should enable one to go with certainty to the immediate vicinity of the mark, and by the measured distances to reference points and the description of the character of the mark, it should inform the searcher of the exact location of the mark and make its identification certain. It should include only essential details of a permanent character." NGS still follows these guidelines, so that a person with a minimal background

in surveying and no local geographic or historical knowledge can easily find the mark by logically following the text of the description.

2.1 FIRST PARAGRAPH - The **first paragraph** is the *description of locality*. This part of the description begins by referring to the airline distance and direction (cardinal or inter-cardinal point of the compass) from the **three** nearest well-known mapped geographic feature(s), usually the nearest cities or towns. Use three references equally spaced around the horizon, if possible. **In writing the Description, always progress from the farthest to the nearest reference point.** Distances in this part of the description shall be in kilometers (followed by miles), or meters (followed by feet), all distances to one decimal place. Detailed measurements which appear elsewhere in the description should not be repeated in this paragraph. Points of the compass should be fully spelled out. Do not use bearings or azimuths. State the name, address, and phone number of public sector property owners (however, phone numbers of private property owners are NOT included). State any advance notice and security access requirements for reaching the station. Also state any unusual transportation methods that may be required to reach the station.

Sample first paragraph:

“STATION IS LOCATED ABOUT 12.9 KM (8.0 MILES) SOUTHWEST OF EASTON, ABOUT 6.4 KM (4.0 MILES) NORTHWEST OF CAMBRIDGE, AND ABOUT 3.6 KM (2.2MILES) EAST OF SMITHVILLE ON PROPERTY OWNED BY MR. H.P. LAYTON, AND KNOWN AS OLD GOVERNOR JACKSONS ESTATE.”

2.2 SECOND PARAGRAPH - The **second paragraph** contains the *directions to reach the station*. This section is one of the most useful parts of a description. It usually enables a stranger to go directly to a station without a delay due to a detailed study of maps or of making local inquiries. It is a route description which should start from a definite point, such as (a) the nearest intersection of named or numbered **main** highways (ideally Interstate and U.S. highways, or at least those which are shown on commonly used road maps), and approximately where that intersection is, or (b) some definite and well-known geographical feature (eg. main post office or county courthouse) and give its name and general location. Odometer distances shall be given to tenths of kilometers (followed by tenths of miles). For roads with names and numbers, give both in the first occurrence.

- a. The format for the first leg of the “to reach” is:
 - I. FROM THE MAIN POST OFFICE IN DOWNTOWN SMITHVILLE, or
 - I. FROM THE INTERSECTION OF INTERSTATE XX AND STATE HIGHWAY YY, ABOUT 3 MI NORTH OF SMITHVILLE,
 - ii. GO A DIRECTION (north, northeast, northerly, northeasterly, etc.),
 - iii. ON A ROAD (name or number of road or highway),
 - iv. FOR A DISTANCE (km followed by miles in parentheses),
 - v. TO SOMETHING (intersection, or fork in road, or T-road left or T-road right).

- b. The format for all other legs:
- I. TURN LEFT OR RIGHT, OR TAKE RIGHT OR LEFT FORK, OR CONTINUE STRAIGHT AHEAD,
 - ii. GO A DIRECTION (north, northeast, northerly, northeasterly, etc.),
 - iii. ON ROAD (name of road or highway),
 - iv. FOR A DISTANCE (km followed by miles in parentheses),
 - v. TO SOMETHING (intersection, or fork in road, or side-road left or right, or station on left or right).

All five parts of each leg shall be included in each "To Reach."

Sample:

"TO REACH THE STATION FROM THE INTERSECTION OF INTERSTATE 300 AND MAIN STREET (STATE HIGHWAY 101) IN JONESVILLE, GO EASTERLY ON HIGHWAY 101 FOR 3.7 KM (2.3 MILES) TO AN INTERSECTION. TURN RIGHT AND GO SOUTH ON MILLER ROAD FOR 5.1 KM (3.2 MILES) TO A SIDE-ROAD RIGHT. CONTINUE SOUTH ON MILLER ROAD FOR 6.6 KM (4.1 MILES) TO AN INTERSECTION. TURN LEFT AND GO EASTERLY ON SMITH ROAD FOR 2.4 KM (1.5 MILES) TO STATION ON THE LEFT IN THE FENCE LINE."

Use the word "EAST" if the road goes due east and "EASTERLY" if the road wanders in a general easterly direction. Use intermediate references, such as Miller Road above, if the distance becomes longer than about 5 miles. The place of the end of truck travel should be mentioned. If walking is required, note the approximate time required for packing. If travel to the station is by boat, the place of landing should be stated.

2.3 THIRD PARAGRAPH - The **third paragraph** provides *details of the mark and reference measurements*. It is made up of six parts: (a) the station mark type, (b) how the mark is stamped, (c) how the mark is set, (d) reference measurements, (e) the handheld GPS position, and (f) PACS or SACS designation, if appropriate. These sections are not numbered in the description, but shall be in the stated order with the stated information.

<u>SECTION</u>	<u>EXAMPLE</u>
(a) - State what the mark is:	THE MARK IS AN NGS HORIZONTAL DISK, OR A USC&GS TRIANGULATION DISK, OR A STAINLESS STEEL ROD, OR A CHISELED "X", ETC.),
(b) - State how the mark is stamped (in dashes):	STAMPED --JONES 1952--.

(c) - State how and in what the mark is set:

THE MARK IS SET IN A DRILL HOLE IN BEDROCK, OR SET IN A SQUARE CONCRETE MONUMENT, OR IS A ROD DRIVEN TO REFUSAL, ETC. A GREASE-FILLED SLEEVE ONE M LONG WAS INSTALLED.

The description shall specify whether the rod was driven to refusal or whether it met the slow driving rate (this is specified in Attachment G, part C-11 as 60 seconds per foot or 90 feet). Also state if a grease-filled sleeve was installed and its length. For a rod mark, the diameter of the stainless steel rod and the diameter of the PVC pipe with the aluminum cap should be in English units, and the length of the plastic sleeve should be given in metric units only.

- State if the mark projects above the ground, is flush, or is recessed and the amount, (for a rod mark state the above for both the rod and the logo cap):

MARK PROJECTS 15 CM (5 IN), OR MARK IS FLUSH WITH THE GROUND, OR MARK IS RECESSED 20 CM (8 IN); OR LOGO CAP IS FLUSH WITH THE GROUND AND TOP OF ROD IS 10 CM

(3.9 IN) BELOW THE TOP OF THE LOGO CAP,

- State the depth of the mark, if known:

CONCRETE MONUMENT, 1.2 M (4 FT) DEEP, OR ROD DRIVEN TO REFUSAL AT 15 M (49 FT)

(d) - State reference distances and directions from three or more permanent objects in the mark's immediate vicinity (farthest to nearest):

IT IS 20.7 M (67.9 FT) SOUTHWEST OF POWER POLE #2345, 15.2 M (49.9 FT) WEST OF THE EDGE OF HIGHWAY 134, AND 3.4 M (11.1 FT) NORTH OF A FENCE LINE.

Examples of objects used as references: existing reference marks, witness posts, center lines of roads, edges of runways, ditches, power or telephone poles, or buildings. Start with the farthest distance. Horizontal distances should be used. If slope distances were measured, that fact should be stated in the paragraph. The distances shall be in meters (followed by English measurement units in parentheses, except as noted in (c) above), and the directions shall be cardinal and inter-cardinal directions, fully spelled out, such as "NORTH", "NORTHEAST", or "NORTH-NORTHEAST". Magnetic bearings from the reference objects are recommended to assist in future recoveries.

(e) Provide a handheld GPS position for all new and recovered marks, and for all proposed mark locations. Include the handheld GPS position in both the scaled position field (in the top portion of the digital description) and in the text, described hereafter. In the text, include the position and the accuracy code of HH1 or HH2, depending on the type of receiver used. HH1 stands for Hand-Held accuracy code 1 (differentially corrected, hand-held GPS), and HH2 stands for Hand-Held accuracy code 2 (stand-alone, hand-held GPS), as follows:

Accuracy code 1 (HH1) = +/- 1-3 meters
 Accuracy code 2 (HH2) = +/- 10 meters

GPS Data Formats:

<u>CODE</u>	<u>LATITUDE</u>	<u>LONGITUDE</u>	<u>SECOND PLACES</u>
HH1	NDDMMSS.ss	WDDMMSS.ss	(2 places of seconds)
HH2	NDDMMSS.s	WDDMMSS.s	(1 place of seconds)

Use “N” or “S” for latitude and “W” or “E” for longitude. Use three digits for the degrees of longitude.

(f) If the station is a Primary or Secondary Airport Control Station mark, the third paragraph shall end with the appropriate designation of Primary or Secondary Airport Control Station):

THIS STATION IS DESIGNATED
 AS A PRIMARY AIRPORT CONTROL
 STATION.

Sample for a rod mark:

“THE STATION IS THE TOP-CENTER OF A 9/16 INCH STAINLESS STEEL ROD DRIVEN TO REFUSAL DEPTH OF 18M. THE LOGO CAP IS STAMPED --SMITH 2003--. THE LOGO CAP IS MOUNTED ON A 5 IN DIAMETER PVC PIPE. A ONE M LONG GREASE-FILLED SLEEVE WAS INSTALLED. LOGO CAP IS FLUSH WITH THE GROUND AND TOP OF ROD IS 10 CM (3.9 IN) BELOW THE TOP OF THE LOGO CAP. THE MARK IS 32.4 METERS (101.74 FEET) NORTHEAST OF NORTHEAST CORNER OF THE HOUSE, 16.62 METERS (54.5 FEET) NORTH OF WATER PUMP ALONGSIDE OF HEDGE AROUND OLD FLOWER GARDEN, AND 4 METERS (12.96 FEET) NORTH OF NORTHEAST CORNER OF HIGH HEDGE ENCLOSING OLD FLOWER GARDEN. THE HH1 GPS IS: 304050.2N, 1201020.4W.”

Sample for a concrete monument:

“THE STATION IS AN NGS HORIZONTAL DISK, STAMPED --JONES 2003-- SET IN A ROUND CONCRETE MONUMENT 1.2 M (4 FT) DEEP AND 0.3 M (12 IN) IN DIAMETER. IT IS SET FLUSH WITH THE GROUND. IT IS 32.4 METERS (101.74 FEET) NORTHEAST OF NORTHEAST CORNER OF THE HOUSE, 16.62 METERS (54.5 FEET) NORTH OF WATER

PUMP ALONGSIDE OF HEDGE AROUND OLD FLOWER GARDEN, AND 4 METERS (12.96 FEET) NORTH OF NORTHEAST CORNER OF HIGH HEDGE ENCLOSING OLD FLOWER GARDEN. THE HH1 GPS IS: 304050.2N, 1201020.4W.”

3.0 IMPORTANT POINTS REGARDING DESCRIPTIONS

3.1 NAMES - Use the station designation (name) and PID, exactly as listed in the NGS database, in all survey records. Do not add dates, agency acronyms, or other information to the name, nor the stamping. Note, frequently the stamping and the official station designation are not the same. For example, stampings include the year set, but designations generally do not.

3.2 TERMINOLOGY - Correct NGS survey terminology shall be used in all station descriptions and reports (see GEODETIC GLOSSARY, NGS, 1986).

3.3 DISTANCES - All measurements are assumed to be horizontal unless labeled “slope.” Distances measured from a line (e.g., the center-line of a road or a fence line) are assumed to be measured perpendicular to that line. The origin of measurements at the junction of two roads is assumed to be the intersection of center-lines of both roads. Measurements are assumed to be from the center of an object (i.e. power pole) unless stated otherwise.

3.4 REPAIR - Any work done to repair a mark shall be described completely in the updated recovery note. Note, a repair strengthens the mark but must not change its position. For example, adding concrete or epoxy around a disk where some is missing is a repair.

3.5 REFERENCE MARK NAMES - Note, reference marks are abbreviated “RM x” in descriptions, but on "Reference Mark" disks they are stamped "NO. x".

3.6 WCHKDESC - Run the digital D-file through the WCHKDESC program (field-level option), one of several programs within the WDDPROC Software Suite, to identify format and coding errors. This program is accessed by (a) running the WDDPROC program and (b) selecting the program, WCHKDESC, from the main menu.

3.7 METRIC CONVERSION - Use 3.2808333333 feet equals one meter.

3.8 ABBREVIATIONS - Meter = M, kilometer = KM, centimeter = CM, mile = MI, nautical mile = NM, feet = FT, inch = IN.

4.0 THE WDESC PROGRAM

The WDESC program, one of several programs within the WDDPROC Software Suite (available over the Web at http://www.ngs.noaa.gov/PC_PROD/DDPROC4.XX/ddproc.index.html), is used to encode

descriptions and recovery notes in D-FILE format for the loading of these descriptions into the NGS database. The NGS Blue Book and the WDESC documentation contain information for properly encoding descriptions. Helpful information is contained in the following paragraphs.

When creating a description file, a backup file is automatically created. Every time a few descriptions are entered, it would be best if they are checked with WCHKDESC and the file corrected. The backup should be renamed **before** reopening the program or it will be overwritten. Always exit from the WDESC program from the pull-down File option Exit. It is recommended to save the description file as a new filename every time the program is exited; saving after each description is entered is also recommended.

Remember to enter “Y” into the satellite usage code field in the *Header Record* if the mark is suitable for GPS observations.

Set the *condition code* on the *Description Header* form as described in **The Description Processing Handbook, Chapter 1, D-FILE Format (for Both Microsoft Windows 95/98/NT and UNIX): The Format of a Description File (D-FILE)**, which is available on the Web by downloading *dformat.htm* from Section 4 of the WDDPROC page (http://www.ngs.noaa.gov/PC_PROD/DDPROC4.XX/ddproc.index.html).

Three separate paragraphs are required in the descriptive text field since they make the description much easier to read. Therefore, when entering the text into the *Description Header* form using the WDESC program, separate each paragraph by pressing the [ENTER] key on the keyboard to add a blank line at the end of the first paragraph.

The FPR code is a field on the *Description Header* form in the WDESC program. Set the “FPR” field in the Description Header form to “F”, “P”, or “R”, for Flush, Projected, or Recessed, respectively. In the description, include the logo cap relationship to the ground surface (projecting above, flush with, or recessed below), and include the distance that the top of the rod is below the top of the logo cap. It is important to include information regarding the exact placement of the logo cap for future reference.

A list of the proper agency codes for the WDDPROC Software Suite can be found on the NGS Web site in WDDPROC ANNEX C (<http://www.ngs.noaa.gov/FGCS/BlueBook/annexc/annexc.index.html>). The agency code to be used for marks that are set by the National Geodetic Survey is NGS. The agency code for marks set by the USC&GS is CGS. Contractors shall use the code assigned to their company. If a contractor does not have a code, a request for one should be emailed to: Burt.Smith@noaa.gov.

5.0 MARK TYPES

5.1 CONCRETE MARK - For a concrete mark set in accordance with the requirements of Attachment E (<http://www.ngs.noaa.gov/AERO/aerospecs.htm#vol1>) use a *setting code* of "07". This classifies the station with a default *vertical stability code* of "C".

5.2 ROD MARK GREATER THAN 4 METERS - For an NGS 3-D stainless steel rod mark driven to a depth of 4 meters or GREATER, use a *monumentation code* of "F" and a *setting code* of "59". This classifies the station with a default *vertical stability code* of "A". Note, if the standard one meter plastic sleeve is used, the vertical stability code must be downgraded to "B".

5.3 ROD MARKS LESS THAN 4 METERS ARE GENERALLY NOT ACCEPTABLE, see "Geodetic Bench Marks," page 27, Table 3.

5.4 DISK IN ROCK OUTCROP - For a disk that is set in solid rock outcrop, use a *monumentation code* of "DH" or "DD" and a *setting code* of "66". This classifies the station with a default *vertical stability code* of "B".

Check the listing of valid *monumentation codes* and *setting codes* in **The Description Processing Handbook, Chapter 1, D-FILE Format (for Both Microsoft Windows 95/98/NT and UNIX): The Format of a Description File (D-FILE)**, which is available on the Web in Annex P of the blue book (<http://www.ngs.noaa.gov/FGCS/BlueBook/>), for the proper codes to use for other types of marks.

Again, refer to the complete directions available at the Web site for using the NGS software package WDDPROC to write the required station descriptions, and be sure to check your final product with WCHKDESC.

ATTACHMENT 6
SAMPLE STATION TABLE (BLANK & FILLED-IN)

TO
GENERAL GUIDANCE AND SPECIFICATIONS FOR
AERONAUTICAL SURVEYS VOLUME A

FEDERAL AVIATION ADMINISTRATION
AIRPORT SURVEYS

Attachment 6 Sample Station Table

(LEW) Auburn-Lewiston Municipal Airport; Lewiston, ME

RECONNAISSANCE CHECKLIST

Station Designation	PID	Station Type	Agency	Horz Order	Vert Order	Stability Code	Recovery Date	Condition	Comments / Recommendations	RECOVERY ATTEMPTED	RECOVERED	CONDITION	LOCATION SKETCHED	VISIBILITY DIAGRAM	PHOTOGRAPHED	DESCRIPTION WRITTEN	DESCRIPTION KEYED	DESCRIPTION CHECKED	RUBBING OF SKETCH	POINT POSITION RECORDED
LEW A	n/a	PACS	--						Proposed PACS, SS rod mark				<input checked="" type="checkbox"/>	<input checked="" type="checkbox"/>	<input checked="" type="checkbox"/>	<input checked="" type="checkbox"/>	<input checked="" type="checkbox"/>	<input checked="" type="checkbox"/>	<input checked="" type="checkbox"/>	<input checked="" type="checkbox"/>
ARP 1964	PF0086	SACS	CGS	A	1	C	17-Nov-02	G	SACS #2	<input checked="" type="checkbox"/>	<input checked="" type="checkbox"/>	<input checked="" type="checkbox"/>	<input checked="" type="checkbox"/>	<input checked="" type="checkbox"/>	<input checked="" type="checkbox"/>	<input checked="" type="checkbox"/>	<input checked="" type="checkbox"/>	<input checked="" type="checkbox"/>	<input checked="" type="checkbox"/>	<input checked="" type="checkbox"/>
LEW AP STA B	PF0085	SACS	CGS	A	1	C	15-Nov-02	G	SACS #1	<input checked="" type="checkbox"/>	<input checked="" type="checkbox"/>	<input checked="" type="checkbox"/>	<input checked="" type="checkbox"/>	<input checked="" type="checkbox"/>	<input checked="" type="checkbox"/>	<input checked="" type="checkbox"/>	<input checked="" type="checkbox"/>	<input checked="" type="checkbox"/>	<input checked="" type="checkbox"/>	<input checked="" type="checkbox"/>
A 196	PF0720	HARN	CGS		1	B	14-Nov-02	G	HARN Tie	<input checked="" type="checkbox"/>	<input checked="" type="checkbox"/>	<input checked="" type="checkbox"/>	<input checked="" type="checkbox"/>	<input checked="" type="checkbox"/>	<input checked="" type="checkbox"/>	<input checked="" type="checkbox"/>	<input checked="" type="checkbox"/>	<input checked="" type="checkbox"/>	<input checked="" type="checkbox"/>	<input checked="" type="checkbox"/>
E 171	PF0723	CBN	NOS	A	1	B	21-Nov-02	G	BM Tie	<input checked="" type="checkbox"/>	<input checked="" type="checkbox"/>	<input checked="" type="checkbox"/>	<input checked="" type="checkbox"/>	<input checked="" type="checkbox"/>	<input checked="" type="checkbox"/>	<input checked="" type="checkbox"/>	<input checked="" type="checkbox"/>	<input checked="" type="checkbox"/>	<input checked="" type="checkbox"/>	<input checked="" type="checkbox"/>
G 171	PF0724	FBN	NOS	A	1	A	17-Nov-02	G	BM Tie	<input checked="" type="checkbox"/>	<input checked="" type="checkbox"/>	<input checked="" type="checkbox"/>	<input checked="" type="checkbox"/>	<input checked="" type="checkbox"/>	<input checked="" type="checkbox"/>	<input checked="" type="checkbox"/>	<input checked="" type="checkbox"/>	<input checked="" type="checkbox"/>	<input checked="" type="checkbox"/>	<input checked="" type="checkbox"/>
M 164	PF0080	--	NOS		1	B	18-Nov-02	NF	Searched 20 min, 2 people	<input checked="" type="checkbox"/>										
ARP RM1	PF1079	CBN	CGS			C	17-Nov-02	G	Not suitable for GPS Obs	<input checked="" type="checkbox"/>	<input checked="" type="checkbox"/>	<input checked="" type="checkbox"/>	<input checked="" type="checkbox"/>	<input checked="" type="checkbox"/>	<input checked="" type="checkbox"/>	<input checked="" type="checkbox"/>	<input checked="" type="checkbox"/>	<input checked="" type="checkbox"/>	<input checked="" type="checkbox"/>	<input checked="" type="checkbox"/>
ARP RESET	PF1080	CBN	CGS	A	3	C	15-Nov-02	G	Too close to Rwy	<input checked="" type="checkbox"/>	<input checked="" type="checkbox"/>	<input checked="" type="checkbox"/>	<input checked="" type="checkbox"/>	<input checked="" type="checkbox"/>	<input checked="" type="checkbox"/>	<input checked="" type="checkbox"/>	<input checked="" type="checkbox"/>	<input checked="" type="checkbox"/>	<input checked="" type="checkbox"/>	<input checked="" type="checkbox"/>
LEW AP STA C	PF0083	FBN	CGS	A	3	C	14-Nov-02	G	Intervisibility problem w/SACS and PACS	<input checked="" type="checkbox"/>	<input checked="" type="checkbox"/>	<input checked="" type="checkbox"/>	<input checked="" type="checkbox"/>	<input checked="" type="checkbox"/>	<input checked="" type="checkbox"/>	<input checked="" type="checkbox"/>	<input checked="" type="checkbox"/>	<input checked="" type="checkbox"/>	<input checked="" type="checkbox"/>	<input checked="" type="checkbox"/>
TARMAC	PF0087	CBN	MEDOT	A	3	C	21-Nov-02	G	Could be destroyed in planned future construction	<input checked="" type="checkbox"/>	<input checked="" type="checkbox"/>	<input checked="" type="checkbox"/>	<input checked="" type="checkbox"/>	<input checked="" type="checkbox"/>	<input checked="" type="checkbox"/>	<input checked="" type="checkbox"/>	<input checked="" type="checkbox"/>	<input checked="" type="checkbox"/>	<input checked="" type="checkbox"/>	<input checked="" type="checkbox"/>

Airport is uncontrolled with restricted access (gate with lock) and no escort required. Radio communications is through VHF UNICOM 122.8. Contact the airport manager, Joe Manager (207) 287-1234 prior to entry. Intervisibility between the PACS and SACS is good. Construction of a new hangar is planned by the SE side of the main tarmac

