

**GUIDELINES/SELF-EVALUATION FOR COMMUNITY DEVELOPMENT
AND CITY OF EL PASO SUBRECIPIENTS**

Agency Name: _____ Telephone: _____

Address: _____ Date: _____

Age of Facility: _____

Person Filling Out Report: _____

Reference*

- 4.6. 1.) **Parking Spaces**
- a. How many total parking spaces? _____
 - b. How many are accessible for the disabled? _____
 - c. How wide is accessible parking space? (8' min.) _____
 - d. How wide is accessible access aisle? (5' or 8' for a van space) _____
 - e. Is the accessible parking space on the shortest accessible route of travel from adjacent parking to the accessible entrance? Yes _____ No _____
If no, please explain:
 - f. Is at least one space a van accessible space (8' space and an 8' access aisle)?
Yes _____ No _____
If not, please explain:
 - g. If a car is parked in the accessible space, is the sign visible? (sign on pole or wall mounted at least 60" above the parking surface) Yes _____ No _____
 - h. Is/are the space/s and access aisle/s level with no slope over 1:50 (2%) in any direction? (Flat) Yes _____ No _____

Table 4.1.1
Figure 9

Total Parking in Lot	Required Minimum Number of Accessible Spaces
1 to 25	1
26 to 50	2
51 to 75	3
76 to 100	4
101 to 150	5
151 to 200	6
201 to 300	7
301 to 400	8
401 to 500	9
501 to 1000	2 percent of total
1001 and over	20 plus 1 for each 100 over 1000

Table 4.1.1

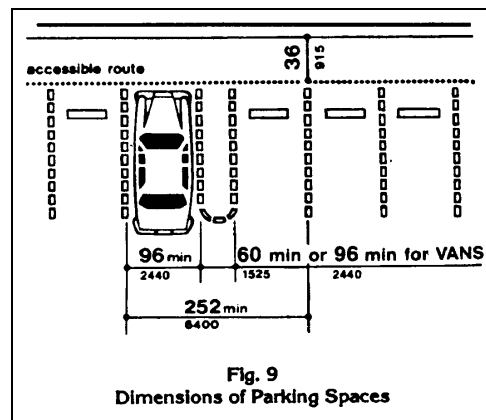

**Fig. 9
Dimensions of Parking Spaces**

Figure 9, 4.6

Reference*

- 4.5 2.) Is there a continuous, smooth, level, hard-surfaced pathway at least 36" wide, with no level changes greater than 1/2" from accessible parking to the entrance? Yes _____ No _____
- 4.8 3.) If there are changes in level, are ramps provided? Yes _____ No _____
- a. What is total change in height (inches)? (more than 1/4") _____
- b. What is the ramp length (feet)? (1' in length for each inch rise) _____
- 4.8.5 c. Are handrails provided? (required if more than 6') Yes _____ No _____
- 4.13.6 4.) Maneuvering Clearance at Door
- Figure 25 a. What are the dimensions of the level maneuvering area at front entrance door? (4' X 5' min) _____
- b. Does the door swing in or out? _____
- c. Indicate approach direction and dimensions of level maneuvering space by drawing entry dimensions as shown in the example below.

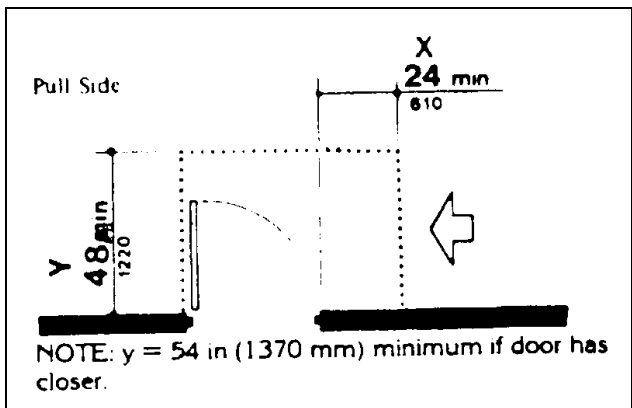
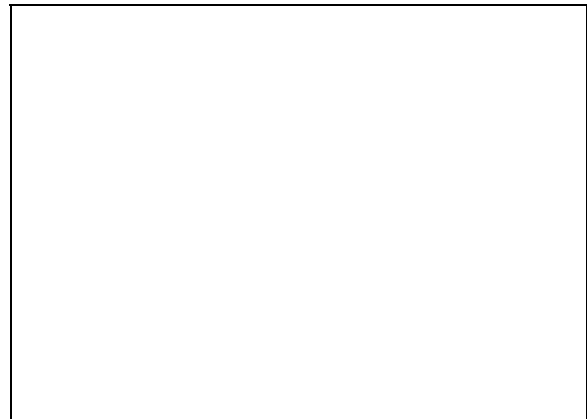

Figure 25



Entry sketch

- 4.13.5 5.) What is the clear width of front entrance when door is open? (32" min.)

- 4.5 6.) Is floor non-skid surface, or low-pile carpet of 1/2" or less and firmly attached? Yes _____ No _____
If no, please explain:

Reference*

- 4.13.5 7.) All interior doors must provide clear width of 32" when open. Complete the following chart for interior doors. (List doors in building)
 a. Do all doors comply? Yes _____ No _____

Room	Clear Width (inches)	Room	Clear Width (inches)
_____	_____	_____	_____
_____	_____	_____	_____
_____	_____	_____	_____
_____	_____	_____	_____
_____	_____	_____	_____

Add additional sheets if needed.

- 4.13.9 b. Do all accessible doors have handles, pulls, latches, locks, and other operating devices that have a shape that is easy to grasp with one hand and does not require tight grasping, pinching or twisting of the wrist to operate? (No knobs)
 Yes _____ No _____
 If no, please explain:

- 4.10 8.) The building is _____ story(ies) high.
 Does the building have an elevator? Yes _____ No _____
 If yes, complete the following:
 a. What is elevator door width? (36" min) _____
 b. What are inside dimensions? (51" X 68") _____
 c. How high above floor are call buttons? (48" to 54") _____
 d. How high are highest car control buttons? (48" to 54") _____
 e. Do control buttons have raised characters or Braille? _____
 If no, please explain:

- 4.4.1 9.) Are all wall-mounted elements (phones, fire extinguishers, signs, etc.) mounted with their leading edges at or below 27 inches? (See Fig. 8 next page.)
 Yes _____ No _____ If no, please explain:
 a. Does the element protrude over 4 inches from the wall? Yes _____ No _____
 b. If the element protrudes over four inches from the wall into the accessible route, is the element protected by means of curb, furniture, ground mounted object, etc.? Yes _____ No _____ If no, please explain:

Reference *

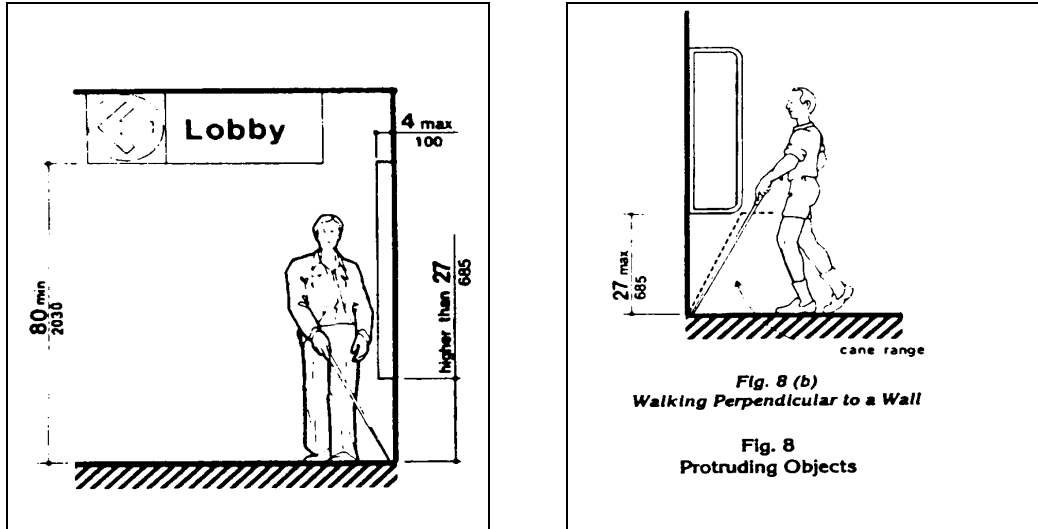

Figure 8

10.) Restroom Facilities

Are toilet facilities provided in rooms having multiple stalls or in individual rooms?

Multiple Stalls _____ Individual Rooms _____

4.17 If multi-stall:

4.13.5 a. What is clear width at main restroom entrance when door is open? (32" min.) _____

4.3.3 b. What is the clear width of the aisle to the accessible stall? (36" min.) _____

4.27.1.1 c. What are the dimensions of the accessible stall? (56" X 60" min.)

Depth _____ Width _____

4.17.5 d. Does stall door swing in or out? _____

4.17.6 e. Does accessible stall/toilet have grab bars? Yes _____ No _____

1. Length of grab bars (36" back 42" side) _____

2. Location (side/side or side/back) _____

3. Mounting height above floor (33" to 36") _____

4.16.3 f. What is toilet seat height from floor? (17" to 19") _____

4.19.2 g. What is lavatory rim height from floor? (34" max) _____

4.19.2 h. Do clearances comply with Fig. 31 & Fig. 32 (below)? Yes _____ No _____

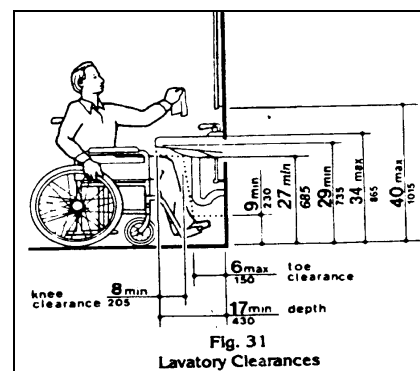
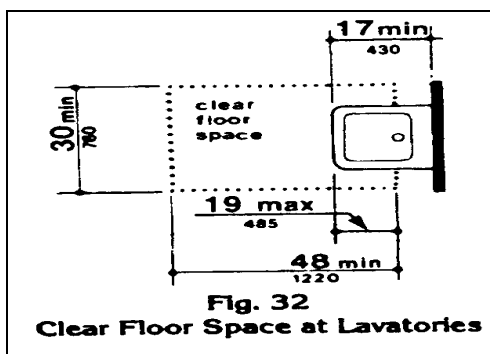

Reference*

- 4.19.3 i. Is there clear floor space of 30" x 48" minimum? (Fig. 31) Yes _____ No _____
- 4.19.4 j. Are hot water and drain pipes below sink insulated or otherwise covered?
Yes _____ No _____
- 4.19.6 k. What are heights of top and bottom edges of accessible mirror from floor?
Bottom edge (40" max.) _____ Top edge (74" min.) _____
- 4.27 l. Are all dispensers easy to reach and no more than 48" from floor to bottom of
dispenser (54" for side reach)? Yes _____ No _____

4.27 If individual toilet rooms are provided, indicate configuration below:

1. Room dimensions (Must have 5' diameter turning area) _____
- 4.22.2 2. Does the door swing into the clear floor space of any fixture? Yes _____ No _____
3. Fixture heights and location

4.16.3 a. What is toilet seat height from floor? (17" to 19") _____

4.19.2 b. What is lavatory rim height from floor? (34" max.) _____

4.26 c. Does accessible toilet have grab bars? Yes _____ No _____

4.17.6 1. Length of grab bars (36" back 42" side) _____

2. Location (side/side or side/back) _____

3. Mounting height above floor (33" to 36" _____

4.27.1 d. Do clearances comply with Fig. 31 & Fig. 32 (above)? Yes _____ No _____

4.19.3 e. Is there clear floor space of 48" x 30" minimum? (Fig. 31) Yes _____ No _____

4.19.4 f. Are hot water and drain pipes below sink insulated or otherwise covered?

Yes _____ No _____

4.19.6 g. What are heights of top and bottom edges of accessible mirror from floor?

Bottom edge (40 in. max) _____ Top edge (74 in. min.) _____

4.27 h. Are all dispensers easy to reach and no more than 48" from floor to bottom

dispenser (54" for side reach?) Yes _____ No _____

4.15 11.) Is at least one water fountain accessible; no more than 36" in height measured from the
floor or ground surface to the spout with a 30" x 48" clear floor space in front of the
water fountain? Yes _____ No _____

If no, please explain:

4.31.3 12.) Is at least one phone accessible to the mobility impaired (no more than 48" from the
floor)? Yes _____ No _____

If no, please explain:

4.31.9 13.) Do you have a Telecommunications Device for the Deaf (TDD)?

Yes _____ No _____

If no, please explain how service is provided to individuals with hearing impairments?

Reference*

4.28.2 14.) Are emergency warning signals both audible and visual?

4.28.3 Yes _____ No _____

If no, please explain:

15.) Is program information that is available in print, available on audio tape or in an alternative method? Yes _____ No _____

If no, please explain:

16.) Are all public meetings accessible (with sign language interpreters) and in accessible locations? Yes _____ No _____

If no, please explain:

*Reference number is from Uniform Federal Accessibility Standards and Americans with Disabilities Act Accessibility Guidelines.

In the case that non-compliant elements are found and structural changes are needed, develop a transitional plan setting forth the steps necessary to complete such changes or alterations. The transitional plan shall contain, at a minimum, identification of physical barriers that limit accessibility; description of methods to make facilities accessible; time schedule for taking each necessary step; costs of changes; and name of person responsible for implementation of plan. Please attach this information to the self-evaluation.

Please be advised that you may have further obligations under the
Americans with Disabilities Act.

For questions or further information regarding these forms, please contact:

Accessibility & ADA Coordinator

General Services

2 Civic Center Plaza

El Paso, Texas 79901

541-4243

Please return Guidelines/Self-Evaluations and Transitional Plan along with the proposal application to the Accessibility and ADA Coordinator.