



Induction Green Heat

Garland Induction Built-in Unit RTCsmp Module-Line "Four Cooking Zones"

Item: _____
 Quantity: _____
 Project: _____
 Approval: _____
 Date: _____

Models:

GI-MO/QU 21000-720

GI-MO/QU 24000-720

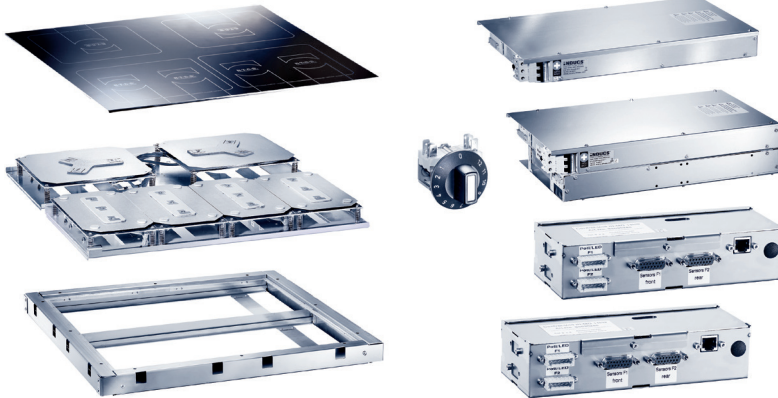

Garland Modular Induction built-in concept with four cooking zones consisting of:

Induction generator, coil carrier sheet with coils and sensors, Ceran glass, control unit, as well as operation and cable kit.

Equipped with the latest RTCsmp (Realtime Temperature Control System) technology.

Standard Features

Induction generator:

A powerful generator that is fully integrated in an enclosed housing and equipped with an integrated fan.

All connections such as the mains cable, operation, CAN cable and sensor cable can be connected externally through plug connections.

The generator is equipped with an air ducting system, through which the heated air is exhausted. Using this design, the risk of a thermal short-circuit is reduced.

Control unit:

The control unit is the information and diagnostic hub for the whole induction unit. It is connected with the generator via RJ45 cable. Compact design and easy to install using special installation tabs/brackets.

Operation unit:

The power switch regulates the temperature in power levels 1 to 12. Simple to operate; adjust the temperature setting simply by turning the knob.

Mounting Frame:

Installation/mounting frame is included with unit.

Coil Carrier Sheet:

Compact design with induction coils and sensors. Engineered specifically for modular kitchen designs.

Full Coil (FL): Rectangular in shape. Several large or small pans can be placed on one surface at the same time.

Round Coil: One pan is used for each heat-zone. Round coils have higher power density and energy efficiency.

Safety above all:

- RTCsmp electronic temperature control that monitors the state of the induction coils, ceramic glass, heat sink and electronics.
- RTCsmp monitors the energy supply.
- Using a special control, interference noises are prevented when operating multiple cooking zones.
- Limiting the energy supply at peak load.
- Automatic monitoring when not cooking, also when using pans with a sandwich base.
- IR interface with diagnostic system.

Optional Features

- Cable kit: 4m (SKU# 95000241) or 6 m (SKU# 95000242).

CE models comply with the latest European Norms: EN 60335-1, EN 60335-2-36, EN 62233 (EMC/EMV)

North American models:

ETL recognized in compliance with UL 197, CSA C22.2 No.109, NSF-4
Complies with FCC part 18, ICES-001



Garland Commercial Ranges Ltd.
1177 Kamato Road,
Mississauga, Ontario
L4W 1X4 CANADA

General Inquiries 1-905-624-0260
USA Sales, Parts and Service 1-800-424-2411
Canadian Sales 1-888-442-7526
Canada or USA Parts/Service 1-800-427-6668



Induction Green Heat
Garland Induction Built-in Unit RTCsmp Module-Line "Four Cooking Zones"

Induction Generator IN/GI-MO 7000/10000

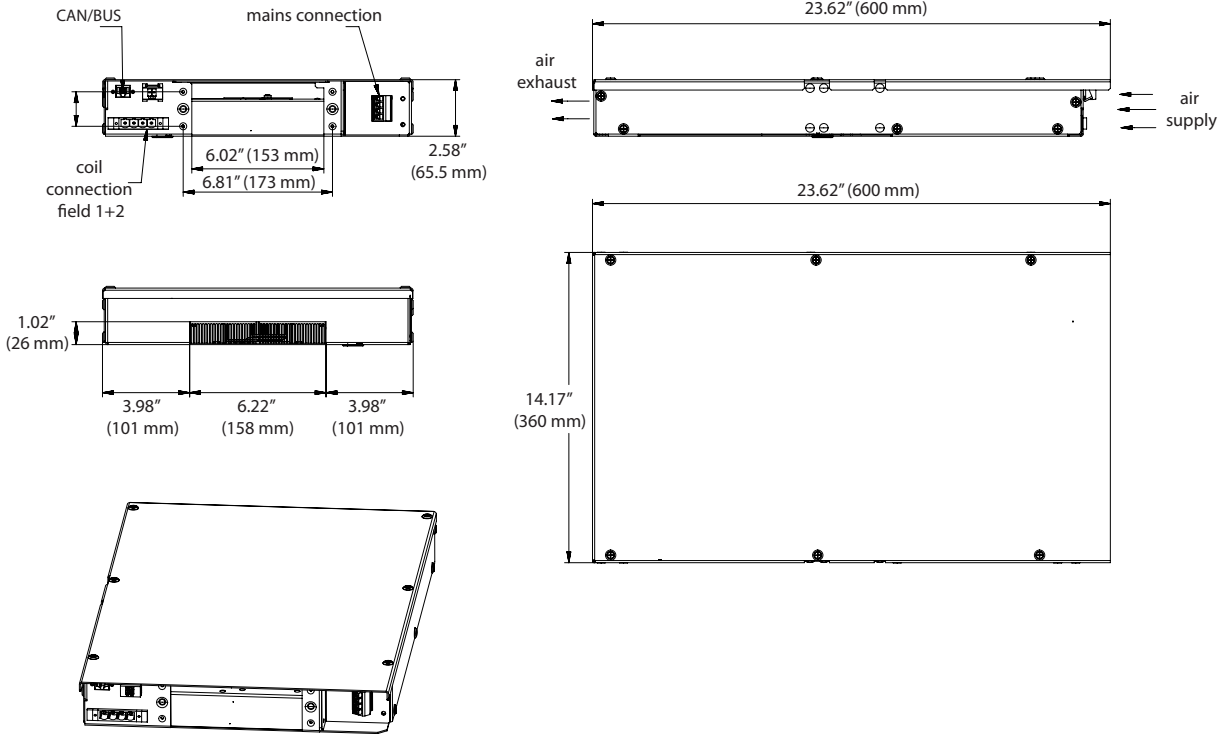

Induction Generator IN/GI-MO 14000FL

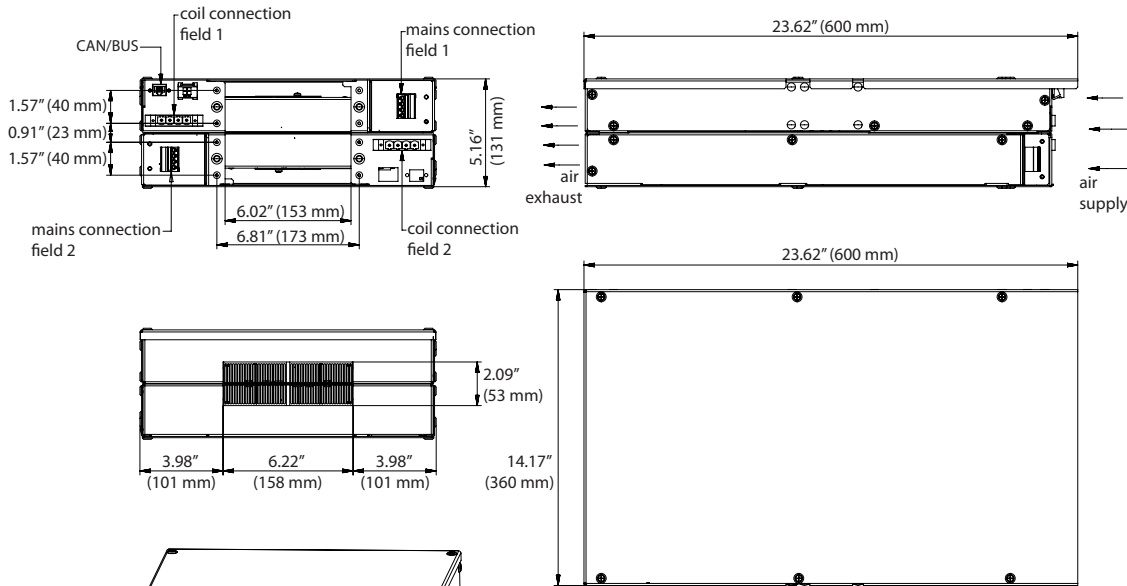

GI-MO/QU 21000-720

Induction Generator: 1 IN/GI-MO 7000 and 1 IN/GI-MO 14000FL

GI-MO/QU 24000-720

Induction Generator: 1 IN/GI-MO 10000 and 1 IN/GI-MO 14000FL

Control Unit IN/GI-MO 7000/10000/14000

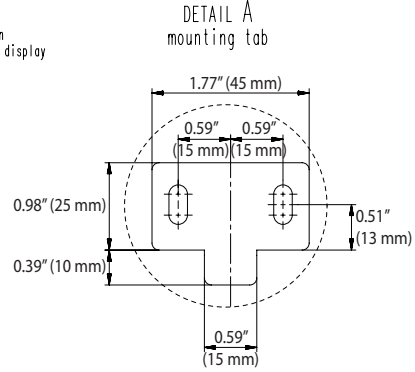
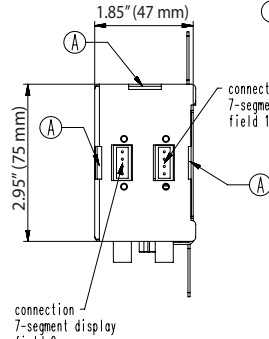
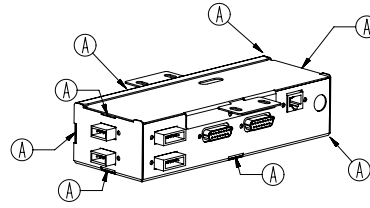
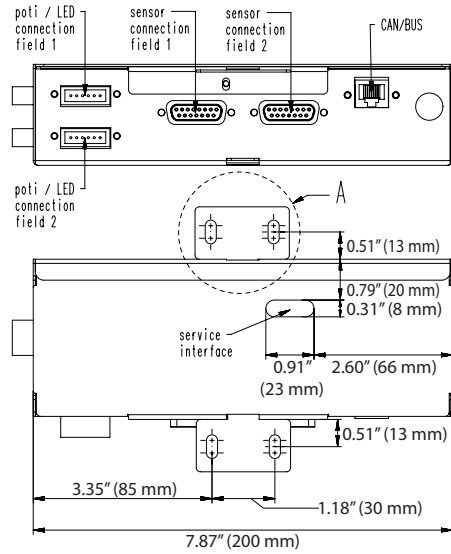

Ⓐ other attachment options with mounting tab

mounting version

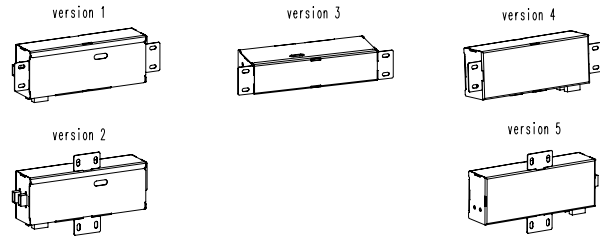

GI-MO/QU 21000-720

Control Unit: 1 IN/GI-MO 7000 and 1 IN/GI-MO 14000FL

GI-MO/QU 24000-720

Control Unit: 1 IN/GI-MO 10000 and 1 IN/GI-MO 14000FL

Coil Carrier Sheet

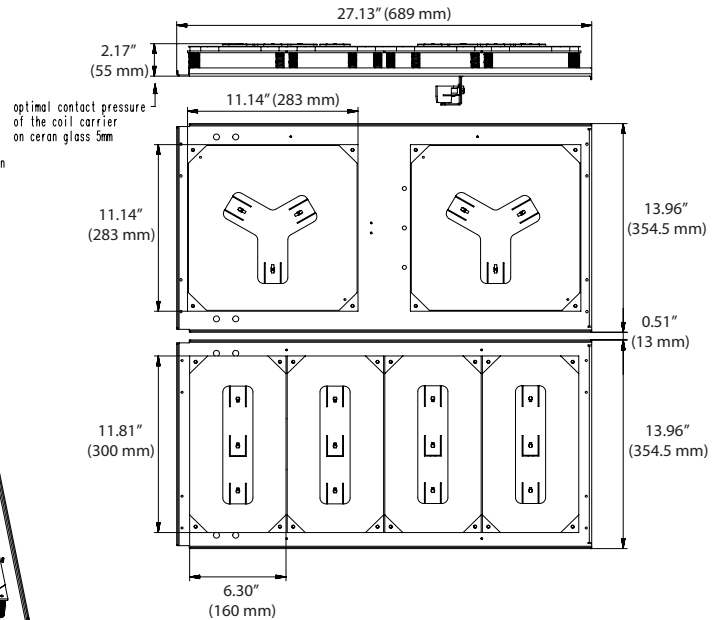
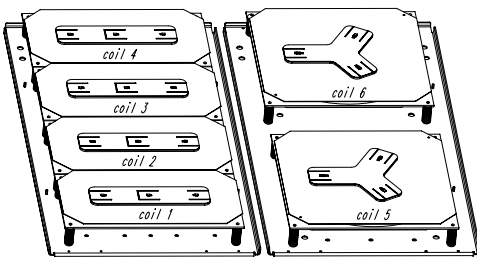
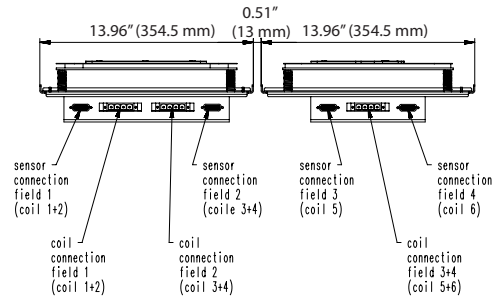

Mounting Frame 720 x 720 mm

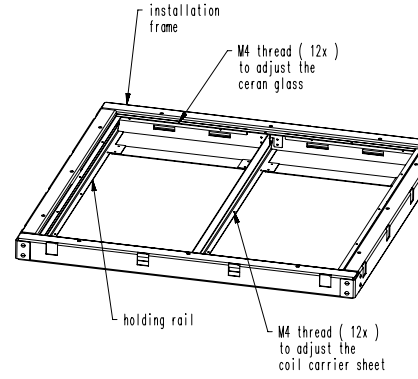
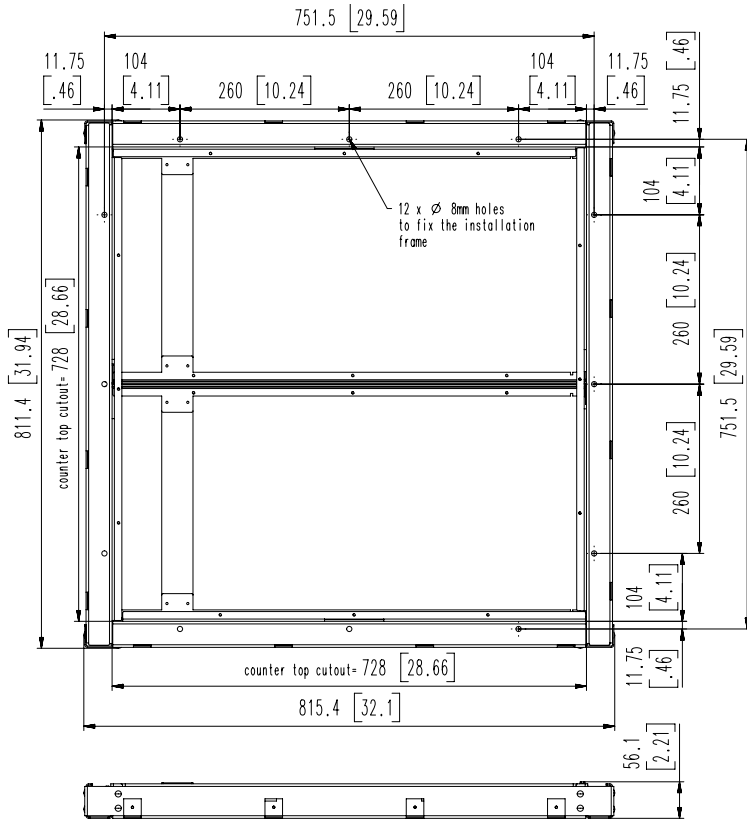

measurements in mm and [inch]

Technical Data

Generator housing:

1x23.62x14.17x2.58" (1 x 600 x 360 x 65.5 mm)

1x23.62x14.17x5.16" (1 x 600 x 360 x 131 mm)

Network impedance (Zmax): 0.25 Ω

Air flow fan: 4238 ft³/h (120 m³/h maximum)

Cut out for air supply: 10.08 sq. in (6500 mm², min)

Number of round coils: 2

Number of rectangular coils: 2

Size of round coils: Ø10.63" (Ø270 mm)

Size of rectangular coils: 5.91x11.42" (150 x 290 mm)

Cable Kit: 8.2 ft (2.5 m)

Model	Ceran Glass Inch (mm)	Power per Cooking Zone	Number of Cooking Zones	Total Rating
GI-MO/QU 21000-720	28.35x28.35x0.24 (720 x 720 x 6)	2 x 3.5 kW 2 x 7.0 kW	4	21.0 kW
GI-MO/QU 24000-720	28.35x28.35x0.24 (720 x 720 x 6)	2 x 5.0 kW 2 x 7.0 kW	4	24.0 kW

Electrical Loading				
Model	Watts	208/60/3	400/50/3	440/50/3
*GI-MO/QU 21000	21000	3 x 22A	3 x 11A	3 x 10A
*GI-MO/QU 24000	24000	2 x 22A 1 x 30A	2 x 11A 1 x 16A	2 x 10A 1 x 15A

***Please note these models have two generators and requires three electrical connections in total**

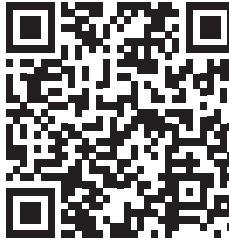

Please note QR code links to manual for this product on our website www.garland-group.com

Garland/ U.S. Range products are not approved or authorized for home or residential use, but are intended for commercial applications only. Garland/ U.S. Range will not provide service, warranty, maintenance or support of any kind other than in commercial applications.

Form# GI-MO/QU 21000/24000-720 (08/21/15)