

HRV

Heat Recovery Ventilators

Installation, Operation and Maintenance Instructions Manual

Capacity: 300 to 1,260 cfm
Model: HRV600i, HRV700i, HRV1200i



Table of Contents

Nomenclature	3
Safety Considerations	4
General Information	4
Recommended Spare Parts	4
Inspection on Arrival	5
Unit Application Limitations	5
Installation	5
Unit Location Requirements	5
Internal Packaging	6
Ceiling Mount	6
Floor Mount	6
Exhaust Dampers for Indoor Units	7
Ductwork	7
Drains	8
Systems Integration	8
Electrical Connections	9
Start-up	10
Pre Start-up Procedure	10
Start-up Procedure	10
Frost Control	12
Sequence of Operation	12
Remote Wall Control	13
Airflow Measurement and Balancing	13
Flow Measuring Station Positions	13
Balancing Procedure	14
Maintenance	14
Bi-monthly Maintenance	14
Annual Maintenance	15
Appendix A: Equipment Data	17
Appendix B: Dimensional Drawings	18
Appendix C: Flow Measuring Station and Balancing Damper Positions	23
Appendix D: Drain Connections	24
Appendix E: Mounting Diagrams	25
Appendix F: Terminal Control Diagrams	26
Appendix G: HRV600i, HRV700i and HRV1200i Start-up Form and Checklist	29
Appendix H: Electrical Control Box and Wire Connections	33
Appendix I: Components	34
Appendix J: Troubleshooting	37
Appendix K: Make-up Heat Requirements	38

Manufacturer reserves the right to discontinue or change specifications or designs without notice or obligation.

Nomenclature

HRV600i Nomenclature (300–750 cfm)

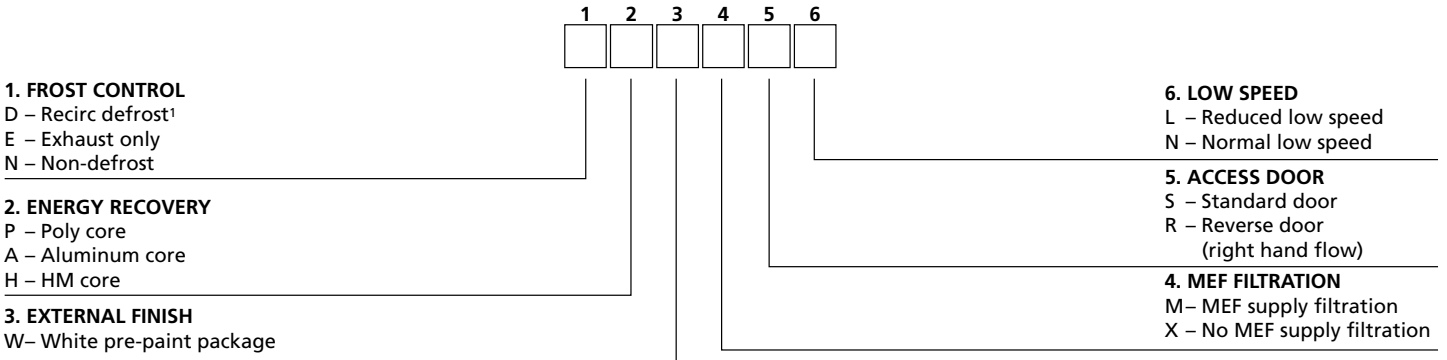

Note:
 1 The recirculation defrost damper module is factory installed.

HRV700i Nomenclature (300–800 cfm)

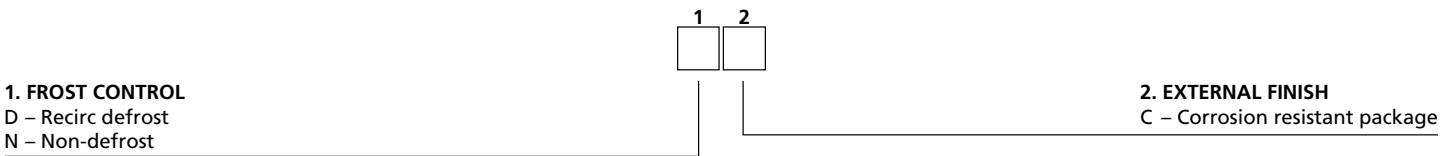

HRV1200i Nomenclature (700–1,250 cfm)

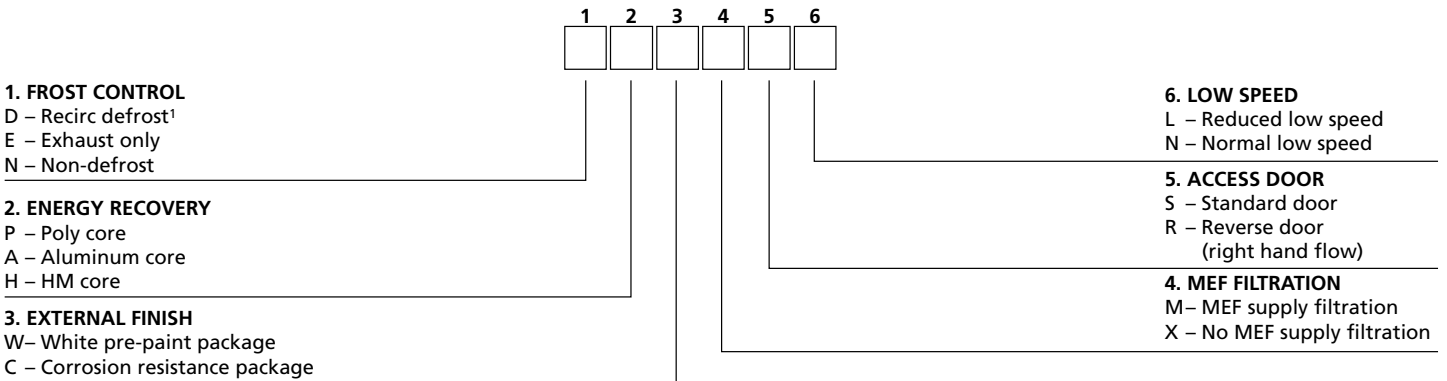

Note:
 1 The recirculation defrost damper module is factory installed.



©Venmar CES 2001. All rights reserved throughout the world.

Illustrations cover the general appearance of Venmar CES products at the time of publication and Venmar CES reserves the right to make changes in design and construction at any time without notice.

CES Group, LLC d/b/a Venmar CES furnishes equipment pursuant to its then-current Terms and Conditions of Sale and Limited Warranty, copies of which can be found under the Terms & Conditions of Sale and Warranty link at www.ces-group.com. Extended warranties, if any, shall be as offered and acknowledged in writing by Venmar CES.

Safety Considerations

Warning, Caution and Important notes appear throughout this manual in specific and appropriate locations to alert Installing Contractors and maintenance or service personnel of potential safety hazards, possible equipment damage or to alert personnel of special procedures or instructions that must be followed as outlined below.

⚠ WARNING

Identifies an instruction which, if not followed, might cause serious personal injuries including possibility of death.

CAUTION

Identifies an instruction which, if not followed, might severely damage the unit, its components, the assembly or final installation.

IMPORTANT

Indicates supplementary information needed to fully complete an instruction or installation.

Hazards may exist within this equipment because it contains electrical and powerful moving components. Only qualified service personnel should install or service this equipment. Untrained personnel can perform basic maintenance such as maintaining filters. Observe precautions marked in the literature and on labels attached to the unit. Follow all safety codes.

⚠ WARNING

Disconnect the main power switch to the unit before performing service or maintenance. Electric shock can cause personal injury.

General Information

This manual is designed to provide general information on the common operation of all standard and optional components that may have been installed in the unit. Note that some sections of this manual may not apply to your unit. This manual has been designed for general purpose and describes options offered by Venmar CES that could be included in the unit. Consult the manual from the

Component Manufacturer if more detailed technical information about a specific component is required.

- Instructions for accessory items which are shipped loose for field installation are included with the item.
- The electrical schematic is attached to the inside of the control panel.
- See [Appendix A](#) for more detailed equipment data.

Recommended Spare Parts

Spare parts should be ordered at the time the installation is accepted by the Owner. Spare parts will reduce the down time in the event of a failure. The list of spare parts outlined below is considered minimal. Installation in remote locations or when the operation of heating equipment is essential may require more spare parts than listed. Please contact the service department at Venmar CES for recommendations.

Minimum spare parts include:

- Two sets of fuses
- One set of filters

Inspection on Arrival

Inspect the equipment exterior and interior for any damage on arrival that may have occurred during unit shipment and for shipped loose parts. Ensure that there is no damage to any protruding exterior components such as the access door, door latches, door hinges, duct collars, cabinet, etc. or to internal components such as fans, motors, flat plate heat recovery module, dampers, actuators and drain pans. File a claim with the shipping company if the unit is damaged. Check the packing slip against all items received. If any items are missing, sign the carrier's

bill of lading with the notation "Shipment Received Less Item #___". Contact the factory immediately if damage is found. No return shipment will be accepted without authorization.

IMPORTANT

The exhaust dampers for indoor units (if ordered) are not installed from the factory and must be installed on site. See [Exhaust Dampers for Indoor Units](#).

Unit Application Limitations

⚠ WARNING

Venmar CES equipment is not designed to be used for temporary heating, cooling and/or ventilation during construction.

Using Venmar CES units for temporary ventilation during construction is subject to the unit warranty terms and should be reviewed carefully before proceeding, as this may void the standard warranty conditions.

Fine dust, larger particulate matter, solvents, varnishes and other chemicals may cause filter clogging and elevated cabinet pressures, higher power consumption and possible irreparable damage to the flat plate heat recovery module, which could reduce energy recovery performance of the plate and damage to other components. Potential damages include, but are not limited to, these examples.

Installation

Unit Location Requirements

Consult local building codes and electrical codes for special installation requirements and note additional requirements listed in this manual. In choosing the installation location of the unit, consider the following factors:

- The unit must be mounted in a heated area to prevent condensate lines from freezing.
- When possible, mount the unit away from occupied areas to provide quiet operation.
- The unit should be installed to allow easy access for maintenance. See [Appendix B](#) for dimensions and recommended service and maintenance clearances.

IMPORTANT

Mounting options must allow 12" [305 mm] clearance in front of the control box cover for access.

- The unit should be mounted close to an exterior partition to minimize the length of insulated ductwork required. Outdoor air intakes and exhaust air discharge should be separated by a minimum of 10 feet [3,000 mm] for Class 2 exhaust or as required by ASHRAE 62.1 to avoid outside cross contamination.

- The fresh air intake must be positioned away from sources of contamination such as hot chimneys or kitchen exhaust vents.
- The unit should be mounted close to a drain and 120V, 60 Hz power supply.
- The unit should be mounted away from hot chimneys, electrical panels and other hazards.
- Locate the unit in an area requiring the least amount of ductwork and directional changes to allow optimum performance, to reduce pressure loss and to achieve proper ventilation. Ductwork must be in accordance with ducting mechanical rules to prevent sound issues and system effects. See [Ductwork](#) and [Appendix C](#) for recommendations on ductwork.
- The unit should be mounted on a level foundation to allow condensation to flow into internal drains. Space must be left under the unit to allow for drain trap height and connection of drain lines. See [Appendix D](#) for specific trap height and connection requirements.

Internal Packaging

Remove access panels and all packaging from the unit. Note that the reinforced rubber straps for ceiling mount are packaged and located inside the unit as may be other remote mounted options and/or accessories. Removal of all packaging is critical.

Ceiling Mount

The unit must be mounted level and may be hung with the reinforced rubber straps provided as shown in [Appendix E](#). Check with local building codes regarding the use of rubber straps in commercial buildings. Attach the straps to the unit with two #8 screws provided. Then attach the other end of the strap to the ceiling joists, trusses, custom frame, etc.

The unit may also be hung with 3/8" [10 mm] threaded rod and U-channels or angles (field supplied) as shown in [Appendix E](#).

Rubber vibration isolation may be required and is recommended for quiet operation. In some regions seismic vibration isolation may be required (isolators field supplied and specified).

IMPORTANT

Do not block access to control box, low voltage terminal strips or line voltage input as indicated in [Appendix E](#). Do not block supply or exhaust ductwork and allow for 1" to 2" [25 to 51 mm] of insulation they may have on them.

Floor Mount

The unit must be mounted level and may be mounted on a metal or wooden curb (not supplied) bolted to the floor as shown in [Appendix E](#). Space must be left under the unit for drain trap height and to allow connection of drain lines. A gradual slope is required for the condensate water to drain by gravity (minimum ¼" per foot [6 mm per 305 mm]). If this is not possible, a pump should be used. See [Appendix D](#) for specific trap height and connection requirements.

IMPORTANT

If attachment of the unit to the curb is required, ensure that screws, bolts and mounting hardware do not interfere with moving parts or that the integrity of the cabinet insulation is not affected.

Exhaust Dampers for Indoor Units

An exhaust gravity backdraft damper is included for indoor units with the recirculation defrost option and shipped loose for field installation. An exhaust gravity backdraft damper or a motorized exhaust damper is available as an accessory for other defrost options or additional use and shipped loose for field installation. Gravity backdraft dampers are for horizontal airflow installations only. Dampers are non-insulated, for installed in duct installation and are ¼" [6 mm] smaller "outside of frame" than the duct size listed. An access panel in the duct on the upstream left hand side (facing the airstream) for the motorized damper is required for access to the actuator and linkage which is mounted and located in the airstream. The damper should be mounted sufficiently far enough downstream from the exhaust fan discharge to avoid system effect added pressure losses. A straight length of duct same size as the unit exhaust discharge and length as indicated in Ductwork followed by the damper and as shown in [Appendix C](#) Note 2 is recommended.

Wiring for the 24V motorized exhaust air damper must be provided and completed in the field by the Installer. A separate 24V, 20 VA power supply is required and must

be field supplied for the motorized exhaust damper. Run the +24V wire connection through the fan interlock contacts on the microprocessor control board or unit terminals 6 and 7 (left side) to break power to the damper when the exhaust fan is not running as shown in [Appendix F](#) for it to spring return closed.

Table 1: Exhaust Dampers for Indoor Units

Model	Venmar CES Part Number	Duct Size (H x W)	Damper Type
HRV600i HRV700i	067120	8" x 14" [203 x 356 mm]	Backdraft (pressure open/gravity closed)
	067121		24V non-insulated motorized (power open/spring return closed)
HRV1200i	067116	8" x 20" [203 x 508 mm]	Backdraft (pressure open/gravity closed)
	067118		24V non-insulated motorized (power open/spring return closed)

Ductwork

The supply and exhaust duct connections on the unit are as follows:

Table 2: Supply and Exhaust Duct Connection Sizes

Unit	Duct Size (H x W)
HRV600i or HRV700i	8" x 14" [203 x 356 mm]
HRV1200i	8" x 20" [203 x 508 mm]

IMPORTANT

Duct sizes are for connection purposes only. Ducts should be sized to keep noise and pressure drop to a minimum.

The supply and exhaust ducts connected to outside, as well as any ducts passing through an unconditioned space, must have a minimum insulation value of R5. In addition, a continuous integral vapor barrier over the duct insulation must be used.

Air balancing dampers are recommended for both supply and exhaust ducts to allow for adjustment of airflow. Also, flexible canvas connectors should be installed close to the unit in the supply duct to the building and the exhaust duct from the building to reduce noise transmission from the unit to the building (see [Appendix C](#)).

All ports on the 600 and 1,200 cfm units have 1" [25 mm] flanges to facilitate the installation of the ductwork. Please note that the outdoor air opening port has a frost control damper incorporated with it. Ensure that any mechanical fasteners used to connect the duct do not interfere with the operation of the damper. Screws can be installed on the side of the cabinet rather than the flange for this port only. For port locations see [Appendix B](#).

IMPORTANT

Straight duct sections minimum of 30" [762 mm] are required on supply to building and exhaust from the building to achieve good airflow performance.

All ports on the 700 cfm unit have 2" [51 mm] flanges to facilitate the installation of the ductwork. Please note the outdoor air opening connection is factory set to be the left side upper port. It is possible to reverse the operation of the frost control damper in order to use the port on top of the cabinet for outdoor air opening connection.

To change the outdoor air opening from the side to the top use a screwdriver to change the rotation reversing switch on the actuator. For port locations see [Appendix B](#).

Drains

The drain fittings provided with the unit will accept a ¾" [19 mm] NPT coupler (supplied by others). The drain line for the unit must be fabricated on site and connected to the building main. A loop in the hose or trap in the copper or plastic pipe must be provided to prevent sewer gases from entering the unit when connecting to a drain as illustrated in [Appendix D](#).

Prime the trap by filling with water before start-up. Check and clear drains annually. Drainage problems can occur should drains be inactive and dry out, or due to reduced water flow caused by buildup of algae. Regular maintenance will prevent these problems from occurring.

IMPORTANT

Consult local building code for plumbing requirements in your area. If copper pipe is to be used, ensure not to solder to the ¾" [19 mm] coupler while it is attached to the plastic drain fitting as deformation may occur. Ensure adequate slope is present to allow good drainage (minimum ¼" per foot [6 mm per 305 mm]).

Systems Integration

Forced Air System

When the Heat Recovery Ventilator (HRV) is installed in conjunction with a forced air system, the air handler and the network of ducts associated with it are used to distribute fresh air inside the building. If this type of system is used, the main fan of the air handler must operate continuously when the HRV unit is on. Fan interlock can be connected to terminals 6 and 7 on the low voltage terminal strips left side on the exterior of the unit (for low voltage Class II circuit only). These terminals are factory connected to dry contacts (FF) on the microprocessor control board in the unit control box. The controller makes relay contact between these terminals when the unit is operating, See [Fan Interlock Switch \(FF\)](#).

Fresh air from the HRV should be introduced into the return duct of the air handler at a point no less than 6 feet [1,829 mm] upstream of the air handler. The duct connection for return air to the HRV should be made on the return air duct at least 2 feet [610 mm] upstream of the fresh air duct connection.

Separate Systems

Select locations for exhaust grilles and supply diffusers to provide effective ventilation and avoid short circuiting airflows through the space. Adjustable dampers should be provided at every grille and diffuser to make balancing of the system possible.

A proper selection of style and size of grilles and diffusers is required to minimize pressure drop. The velocity of the

airflow should not exceed 400 feet per minute [2 meters per second] for normal applications.

The duct system should be designed according to the high speed flow rate of the unit. In order to keep the noise and pressure drop to a minimum, a maximum air velocity of 1,100 feet per minute [5.6 meters second] should be used in calculations in duct design. The duct runs should be kept as short as possible with the minimum amount of elbows and transitions. The Manufacturer recommends the use of smooth radius elbows or square elbows with turning vanes to achieve maximum performance.

Dampers

An insulated motorized outdoor air damper is included with the unit with recirculation defrost or exhaust only defrost which closes during a frost control cycle or placed in the 'Off' position with power maintained to the unit. Outdoor air damper will remain open if power is disconnected from the unit while operating in heat recovery mode.

A backdraft gravity damper is supplied with recirculation defrost units to be installed in the exhaust air outlet duct on indoor units. This damper is necessary to prevent air from entering the building through the exhaust duct when the unit is in recirculation defrost mode. See [Exhaust Dampers for Indoor Units](#) for further installation details. Mount the damper in the exhaust air to outside duct as shown in [Appendix C](#) and [Ductwork](#) for fan outlet duct considerations.

Electrical Connections

⚠ WARNING

When installed, the unit must be electrically grounded in accordance with local codes or, in the absence of local codes, with the National Electrical Code, ANSI/NFPA70, and/or the Canadian Electrical Code CSA C22.1. Unit cabinet must have an uninterrupted, unbroken electrical ground to minimize the possibility of personal injury if an electrical fault should occur. Failure to follow this warning could result in the Installer being liable for personal injury of others.

Power Supply

A terminal block and strain relief bushing or a junction box is provided for line voltage in power connection. See [Appendix B](#) for location.

The unit's power line input power supply electrical requirements are as follows:

Table 3: Electrical Requirements

	600 CFM	700 CFM	1,200 CFM
Voltage	120V	120V	120V
MCA	9.5	6.6	14.3
MOP	12.0	9.0	20.0

The units do not have a factory installed disconnect switch. If disconnect is required field supply and install as per NEC/Canadian Electrical Code. Use copper conductors only.

All field wiring must comply with NEC and local requirements. In Canada, electrical connections must be in accordance with CSA C22.1 Canadian Electrical Code Part One.

Field Connections

A wiring diagram is located inside the control box cover. Low voltage terminal strips for remote control wiring interface are provided on the exterior casing of the unit and connected to the microprocessor control board for starting, controlling sequence and monitoring. The Installer must provide wiring for the controls and/or accessories that may be supplied optionally or by others to the low voltage terminal strips. See [Appendix B](#) for location.

The controls available for the Heat Recovery Ventilators, their reference and type of connection are listed below. For more information on the controls, wiring and terminal connections see [Appendix F](#).

The wall control is 12 VDC. Other terminals are 24 VAC or dry contact control.

Notes:

1. Check the Controls and/or the Control Schematic sections of the specification, optional and accessory items shipped loose with or inside the unit for a list of optional controls or wiring connections required to the unit.
2. For the unit to start both ventilation and fan speed calls are required except as noted. For ventilation call the remote wall control, occupied timer/sensor, manual switch or BMS contacts can be used. For fan speed call the remote fan control, CO₂ ventilation control, manual switch or BMS contacts can be used.

Wall Control Connection

- Four-wire LVT 24 gauge minimum (12 VDC).

Occupied Timer/Sensor Connection

- Makes a dry contact to operate unit. Timer requires separate 24 VAC. Do not use timer with Xtra wall control.

Remote Fan Control

- Requires single pole, double throw switch for Low–Common–High.
- Makes dry contact for speed setting.

CO₂ Ventilation Control

- Makes dry contact.
- CO₂ ventilation requires separate 24 VAC.

Smoke Detector

- Makes dry contact.
- Smoke detector requires separate 24 VAC.

Fan Interlock Switch (FF)

- External fan control can be achieved by connecting an external fan source (G) through dry contacts (FF) on the microprocessor control board (terminals 6 and 7 on the low voltage terminal strips left side). These contacts are closed on a call for ventilation or frost control. See [Forced Air System](#).

Start-up

Pre Start-up Procedure

Before requesting start-up, check that the installation is complete and unit is ready. Complete the pre start-up check list below and in [Appendix G](#) for each unit as items are checked.

1. Check the electrical disconnect is in the 'Off' position.
2. Open access doors and check the unit for shipped loose parts, obstructive packaging, objects near or in fans, dampers, flat plate exchanger, etc.
3. Check that the fans and motors are rotating freely.
4. Check that the air filters are installed and clean. Replace if necessary.
5. Check damper and linkages for free movement.
6. Check that ductwork is connected and complete.
7. Check that condensate drain connections have been trapped, installed correctly and filled.
8. Check that all shipped loose or field supplied components have been correctly installed and wired.
9. Check that all power supplies and control wiring have been inspected and approved by the Local Authorities having jurisdiction.
10. Check all factory and field wiring connections for tightness. Tighten if necessary.
11. Check that all fuses are properly installed in holders.
12. Check the voltage at the disconnect switch against the nameplate. If the voltage is not within 10% of rated have the condition corrected before continuing start-up.
13. Check that all field piping, venting, installation and connections for the heating and cooling options and/or accessories (if equipped) have been completed and tested.
14. Check and adjust thermostat setpoints.

Start-up Procedure

To ensure proper operation of each unit, qualified personnel should perform the start-up and complete the checklist below and the start-up form in [Appendix G](#) for permanent record. A completed checklist will provide valuable information for personnel performing future maintenance.

IMPORTANT

A completed copy must be sent back to the factory for warranty validation and for factory assistance.

All units are factory run tested. Fans are set up to run correct when power is connected. All units are dynamically balanced prior to shipping. However, there are certain operating speeds at which the natural frequency of the rotating member is attuned to the natural frequency of the unit panels, which may cause vibrations.

These vibrations can tend to reinforce each other in such a way that excessive vibration can be encountered under certain conditions. It is difficult to predetermine this condition because it is affected by the mounting arrangement and the various modules used to make up the assembly and the ductwork connections.

If the above check reveals no apparent discrepancies and vibration is still present, the speed of the unit should be changed to determine if the natural frequency is causing the vibration.

Under no condition should the unit(s) be allowed to continue to operate when excessive unit vibration is apparent. Permanent damage may result which will not be covered under the warranty if the unit is allowed to continue in operation when excessive vibrations are evident.

1. Before proceeding complete the pre start-up checklist.
2. For the unit to start when the disconnect switch is turned on, a ventilation and fan speed call is required.
 - a. Check for ventilation call from the remote wall control connection, occupied timer/sensor connection or BMS whichever is used. See [Appendix F](#) for which terminal connections should be closed (contacts made) once power is connected. Circle which device is used.
 - b. Check for either low speed or high speed call from the remote fan control, CO₂ ventilation control or BMS whichever is used. See [Appendix F](#) for which terminal connections should be closed (contacts made) once power is connected. Circle which device is used.
 - c. If 'a' and 'b' are not connected, start can be accomplished by using temporary external dry contacts or a jumper wire closing timer contacts 3 and 4 (left side) plus low speed contacts 3 and 4 (right side). Check if temporary dry contacts or a jumper wire are used.

⚠ WARNING

Only low or high speed contacts must be closed at any one time never both using dry contacts/jumper wires otherwise permanent damage to the motor and wiring will occur.

Remote controls, if installed and connected, operate in conjunction with the dry contacts/jumper wires. When controlling units with remote controls, use extreme caution around moving mechanical components such as fans, belts and motors as they can lead to severe personal injury.

3. Check that all access panels or doors are closed.
4. Turn the unit disconnect switch to the 'On' position.
5. Wait for fans to run and then shut off unit's disconnect switch. Check that fans are rotating in the correct direction.
Note: If there is a negative pressure in the space and an exhaust discharge damper is missing or not closing properly, the fans with single-phase motors could be rotating in the wrong direction before the power is turned on and may not correct itself. Check the exhaust damper is present and dampers are closing properly or take corrective action before proceeding.

IMPORTANT

On initial power up, the unit will perform a system check and operate at high speed for five seconds.

6. Check that dampers are operating properly.
7. Close all access doors and turn the unit's disconnect to the 'On' position.
8. Re-check the voltage at the disconnect switch against the nameplate with all fans operating. If the voltage is not within 10% of rated have the condition corrected before continuing start-up.

9. Check amperage draw to each motor against motor nameplate FLA. **Do not** allow the motor amp draw to exceed the Motor Manufacturer's nameplate data. Excessive amp draw will cause premature failure of the motor and **void** the motor warranty. If significantly higher, adjust the manual balancing dampers in the ductwork (change the ductwork static pressure) to lower the amperage draw below the nameplate FLA.
10. On the HRV600i and HRV1200i there are three speed settings available with the controls, only two of which can be functional. The units are factory set to use the low and high speed taps on the blower motors. If additional airflow is required, the medium speed tap can be used instead of the low speed tap. See [Appendix H](#) for instructions on how to make this change.
11. Check the fan operation on Low, Com and High. Use a wall control or the dry contact switching to run fan speeds as shown in Appendix F, [Wall Control Connection](#).
12. Check the operation of the control options and accessories provided with the unit. See [Frost Control](#), [Sequence of Operation](#) and [Appendix F](#) for functional descriptions and further details.
13. Check the setpoints on thermostats and controls; adjust and record changes as required.
14. When unit has achieved steady state take measurements and complete the readings section of the Start-up Form in [Appendix G](#) and send copy of the Start-up Form to Venmar CES to validate warranty. Maintain a copy of the report at the unit for future reference.

Frost Control

The unit functions are controlled by an integrated microprocessor control board included in the unit as per the frost control selected, the sequence of operation as described below and according to the options selected as described in [Appendix F](#).

Exhaust Only Defrost

The exhaust only frost control cycle is electronically controlled in response to outside air temperature. On a call for defrost, the outside air damper and the heat exchanger core damper close, the supply fan is de-energized and the exhaust fan continues to draw warm room air through the flat plate heat exchanger to remove the buildup of ice. Frost control is initiated at an outdoor temperature of 23°F [-5°C]. The defrost/ventilation cycle is time and temperature based per Table 4.

Recirculation Defrost

The recirculation frost control cycle is electronically controlled in response to the outside air temperature. On a call for defrost, the outside air damper closes, the exhaust fan is de-energized, the exhaust gravity backdraft and/or motorized damper closes, the recirculation defrost damper opens and the supply fan circulates warm air through the flat plate heat exchanger to remove the buildup of ice. For the HRV700i, it is possible to extend the frost control times during very cold weather by removing the jumper JU1-F on the circuit board. Frost control is initiated at an outdoor air temperature of 23°F [-5°C]. The defrost/ventilation cycle is time and temperature based per Table 4.

Table 4: Recirculation (R) and Exhaust Only (E) Defrost

HRV Model	Stage	Type of Defrost	Initiate Temperature		Ventilation Time (Minutes) Defrost Time/Run Time	
					Standard	Extended
Aluminum and Polypropylene Core Heat Exchangers						
600i 1200i	1	R/E	23°F	-5°C	12/60	N/A
	2	R/E	5°F	-15°C	12/24	N/A
	3	R/E	-21°F	-30°C	12/12	N/A
700i	1	R	23°F	-5°C	6/60	10/28
	2	R	5°F	-15°C	6/32	10/28
	3	R	-21°F	-30°C	6/19	10/15
Heat and Moisture (HM) Core Heat Exchangers						
600i 1200i	1	R/E	23°F	-5°C	10/50	10/30
	2	R/E	5°F	-15°C	10/30	10/20
	3	R/E	-21°F	-30°C	10/20	10/15

Non-defrost

No frost control can be used only in areas where the winter outdoor air condition stays above 23°F [-5°C] and the return air humidity level is below 20%.

Sequence of Operation

IMPORTANT

On initial power up, the unit will perform a system check and operate at high speed for five seconds.

Unit Check Points

- *Power connected, no ventilation call* – Both fans are off, frost control damper (if equipped) closes off fresh air from outside.
- *Power connected, low speed call* – Both fans on low speed, internal frost control damper (if equipped) opens fresh air from outside. If equipped with recirculation module, the internal frost control damper closes recirculation opening.
- *Power connected, high speed call* – Both fans on high speed, frost control damper opens fresh air from outside. If equipped with recirculation module, the internal frost control damper closes recirculation opening.
- *Power connected, occupied timer/sensor connection open (unoccupied mode)* – Both fans are off, frost control damper closes fresh air from outside. If equipped with recirculation module, the internal frost control damper opens recirculation opening.
- *Power connected, FF control contacts close during unit ventilation or frost control cycle.*

Remote Wall Control

Remote mounted wall control options are solid state controls that can be used to control the ventilators from a remote location. The connection from the ventilator to the control is low voltage and requires a four conductor (24 gauge minimum) LVT cable. Models are available with a dehumidistat control and speed switching. The following three options are available:

Standard Wall Control

Dehumidistat to engage high speed exchange. Slide switch operation supporting continuous low exchange and continuous high exchange.

Xtra Wall Control

Dehumidistat to engage high speed exchange. Electronic push button operation supporting intermittent (standby) ventilation, continuous low exchange, continuous high exchange, maintenance indicator light and exchange indicator light.

Aqua Air Wall Control

Ideal for pool dehumidification. Dehumidistat to engage high speed exchange. Electronic push button operation supporting intermittent (standby) ventilation, continuous low exchange, continuous high exchange, maintenance indicator light and exchange indicator light.

Airflow Measurement and Balancing

Once installation is complete, the supply and exhaust airflows should be balanced to ensure proper operation and a good quality installation. A well designed duct system with properly sized duct runs and equal static pressure losses of both the supply and exhaust will aid in airflow

balancing. However, it will be necessary to take flow measurements using AMCA suggested methods. The recommended methods would be a velocity traverse measurement or flow measuring stations (FMS) installed in the ducts with magnehelic pressure gauges.

Flow Measuring Station Positions

It is important to locate the FMS in the 'warm side' ductwork to minimize the effect of differences in air density, especially when balancing during extremely cold outside conditions. Air density variations can affect the FMS by more than 15%. The FMS should be located downstream from straight sections of duct and not immediately after fans or obstructions that will cause turbulent flow. Flow control or balancing dampers should be installed downstream from the FMS so flow through the FMS is not disturbed. Dampers can then be adjusted to equalize flow rates in the ducts.

Whether flow stations are permanently installed or used temporarily, the position they are placed in is very important to ensure accuracy as shown in [Appendix C](#). The best locations for mounting the FMS is in the long straight sections of ducting where airflow has stabilized across the area of the duct. This position will provide the most accurate measurements.

The next best location for the FMS is immediately before or after a 90 degree elbow and 12" [305 mm] from any damper. In straight sections of pipe, the FMS should be installed at least 30" [762 mm] from any fan outlet. This applies to the supply air opening connection on the HRV and the exhaust air opening connection.

With airflow measuring stations permanently installed, balancing is done by measuring airflow on one side of the HRV and then the other. Adjustments can then be made to the damper to equalize airflows.

When using the temporary method, an FMS is installed in one air duct of the HRV and the flow recorded. The FMS is then relocated to the other air duct and the airflow is recorded again. Dampers can then be adjusted to equalize airflow. This procedure should be repeated to ensure that the unit is balanced properly.

Balancing Procedure

Before proceeding with balancing, all windows, overhead doors and walk-in doors should be closed and exhaust systems should be turned off.

The connections between the flow stations and the ducts must be sealed with tape. Mount the magnehelic gauge in a convenient location where it is level and will not vibrate or be bumped. Zero the gauge. Measure the exhaust air first as it is often the lowest due to a longer duct system.

With the fan speed at maximum, connect the hoses from the FMS to the magnehelic gauge. If the needle falls below zero, reverse the hose connections. Ensure that the damper is wide open. Take a reading from the magnehelic

gauge and record it. Remove the FMS and place it in the supply duct. This process is not necessary if the FMS is to be permanently mounted.

Repeat the procedure. If the reading is higher in the supply duct, adjust the damper until the reading is the same. If the reading is lower, return the FMS to the exhaust duct and adjust the damper to obtain the same reading as the supply duct.

Maintenance

WARNING

Disconnect the main power switch to the unit before performing service and maintenance procedures.

See [Appendix A](#) for physical data on units, [Appendix I](#) for component locations and [Appendix J](#) for troubleshooting information. A more detailed description of major maintenance items and timeframes follows.

Bi-monthly Maintenance

Bi-monthly maintenance should include:

Air Filters

The standard foam filters are washable. Under normal conditions it is recommended that they be cleaned every two months. More frequent cleaning may be required under extremely dirty operating conditions. Use a vacuum cleaner to remove the heaviest portion of accumulated dirt, then wash with warm water.

A medium efficiency filter for the supply airstream is available from your Supplier. This filter is disposable and should be replaced when it becomes dirty.

Drain Pans and Interior of Unit

With the filters removed from the unit, the foil faced insulation surfaces and drain pans should be wiped clean with a soft cloth and mild cleaning solution. Ensure that the drain fittings are free from dirt and draining freely.

Annual Maintenance

⚠ WARNING

Disconnect the main power switch to the unit before performing service and maintenance procedures.

Annual maintenance should include:

Air Filters

Vacuum and wash standard foam filters. Replace medium efficiency filter if present.

Drain Pans and Interior of Unit

Wash the foil faced insulation surfaces and wipe the drain pans with a soft cloth and mild cleaning solution. Check the drain fittings to ensure they are draining freely.

Flat Plate Heat Exchanger

⚠ WARNING

Hot water and strong cleaning agents could damage the heat exchanger. Ensure the heat exchanger is returned to the unit in the correct orientation. Failure to do so may result in damage to the exchanger. Follow instructions on the label.

The flat plate heat exchanger must be handled with care. Remove the flat plate heat exchangers by sliding them out from the tracks holding them in place. In order to ensure maximum efficiency of the partitions, it is recommended that the heat exchanger be cleaned once a year following the season of most intense use. For polypropylene and aluminum media, allow the heat exchanger to soak for three hours in warm water and mild soap. Rinse under a heavy stream of water. For HM heat exchangers, use a vacuum cleaner or low pressure air. It is not recommended to use solvents or detergents as these may damage the media or structure of the heat exchanger. When replacing the flat plate heat exchanger sections, ensure they are of the proper vertical orientation. Failure to do so may result in low airflow on the exhaust airstream due to system pressure trapping or holding condensate in the flutes.

Fans

Blower wheels and fan housing should be checked for dirt buildup. If they appear dirty, it may be necessary to remove the blower assembly and then vacuum the dust out through the fan mouth. See Figure 1 and Figure 2 for instructions on removing the blower assembly.

System Operation Check

Verification of all control modes should be checked to ensure proper operation. Refer to [Sequence of Operation](#).

Testing and Replacement of the Damper Actuator

Check damper operation by switching between Low-Com or High-Com on the low voltage terminal strips or by switching through the modes on the optional remote wall control. If the damper does not respond in one or both directions, check all connections.

700 cfm Only

Check for 24V output between the white/red and the white/orange wires at the damper motor. If 24V can be measured at the damper motor, the problem is either in the connections, the frost control relay or the microprocessor control board.

600 and 1,200 cfm Only

CAUTION

120 VAC.

With the unit powered but off, check for 120V output across the white/black wires. If 120V can be measured at the motor, replace the motor. If 120V cannot be measured at the motor, check for 120V across pins J1-9 and J1-1 at the microprocessor control board.

Microprocessor Control Board Replacement

The microprocessor control board must be replaced if an electronic problem arises. For example, the unit suddenly stops, the unit stays in frost control mode all the time or if control functions are not working properly.

Ensure that power is reaching the microprocessor control board. Test the blower motors and damper actuators for operation when directly connected to the appropriate power voltage. If the motor and damper actuators function normally, replace the main microprocessor control board.

Motor and Blower Removal and Installation

Disconnect power from the unit. To determine if the fan motor is burned out, disconnect the four-wire service connector between the motor and cabinet. Connect the motor directly to a 120V power source with an electrical cable as follows:

Table 5: Motor Connections

Red + White	Low speed
Blue + White	Medium speed
Black + White	High speed

⚠ WARNING

Disconnect the main power switch to the unit before performing service and maintenance procedures.

If the motor functions normally, there is a problem with the wiring connections or the microprocessor control board. Check all wiring and replace microprocessor control board if necessary.

If the blower does not run, it must be replaced. To replace the motor, remove the flat plate heat exchanger from the unit. Disconnect the four-wire service connector from the unit. Remove the fasteners holding the motor assembly in place. Lift the assembly up and out, using one hand under the motor and one hand to steady it. Remove the assembly carefully from the unit to avoid damage to the insulation, shelf, etc. Install the repaired motor assembly by following these instructions in reverse.

Figure 1: Blower assembly removal – HRV600i and HRV1200i

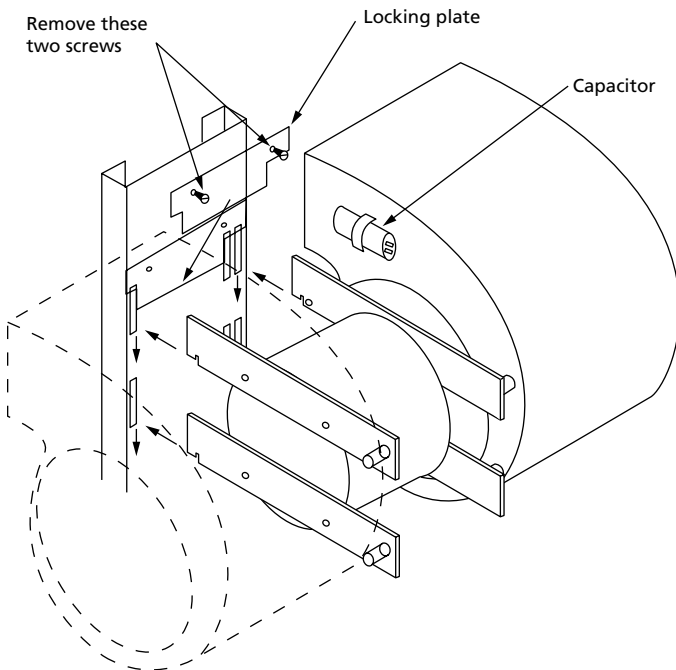
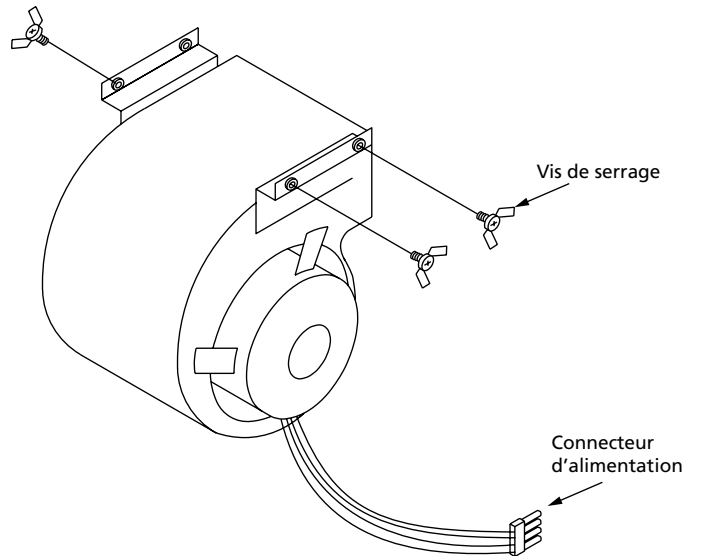

Figure 2: Blower assembly removal – HRV700i



Appendix A: Equipment Data

Table A1: Equipment Data

	HRV600i	HRV700i	HRV1200i
Airflow Range	300 to to 750 CFM	300 to 800 CFM	700 to 1,250 CFM
Fans			
Supply type	Direct drive	Direct drive	Direct drive
Wheel type	Forward curved	Forward curved	Forward curved
Wheel size	Ø7" x 6" [Ø178 x 152 mm]	Ø9" x 7" [Ø229 x 178 mm]	Ø7" x 6" (two) [Ø178 x 152 mm]
Bearing	Sleeve direct drive	Sleeve direct drive	Sleeve direct drive
Housing	Cold rolled	Cold rolled	Cold rolled
Shaft	½" [13 mm]	½" [13 mm]	½" [13 mm] keyed
Motor (HP)	¼	⅙	⅓
Exhaust type	Direct drive	Direct drive	Direct drive
Wheel type	Forward curved	Forward curved	Forward curved
Wheel size	Ø7" x 6" [Ø178 x 152 mm]	Ø9" x 7" [Ø229 x 178 mm]	Ø7" x 6" [Ø178 x 152 mm]
Bearing	Sleeve direct drive	Sleeve direct drive	Sleeve direct drive
Housing	Cold rolled	Cold rolled	Cold rolled
Shaft	½" [13 mm]	½" [13 mm]	½" [13 mm] keyed
Motor (HP)	¼	⅙	⅓
Flat Plate Heat Recovery Module			
Size	12" x 12" x 26" [305 x 305 x 660 mm]	23" x 23" x 19" [584 x 584 x 483 mm]	12" x 12" x 39" [305 x 305 x 991 mm]
Flat plate material	Polypropylene, aluminum or HM	Polypropylene	Polypropylene, aluminum or HM
Filters			
Type (primary)	Washable foam	Washable foam	Washable foam
Size	13" x 11" x 1" [330 x 279 x 25 mm]	22.25" x 19" x 1" [572 x 483 x 25 mm]	13" x 11" x 1" [330 x 279 x 25 mm]
Number per airstream	2	1	3
Type (secondary)	MEF	MEF	MEF
Size	13" x 11.25" x 2" [330 x 286 x 51 mm]	22.625" x 19.25" x 1.75" [575 x 489 x 51 mm]	13" x 11.25" x 2" [330 x 286 x 51 mm]
Number per airstream	2	1 (See Note 1)	3
Weight (With Recirculation Defrost)			
Net core weight maximum			
Polypropylene	197 lbs [90 kg]	210 lbs [95 kg]	247 lbs [112 kg]
Aluminum	204 lbs [93 kg]	n/a	257 lbs [117 kg]
HM	208 lbs [95 kg]	n/a	264 lbs [120 kg]
Shipping weight	Add 40 lbs [18 kg]	250 lbs [114 kg]	Add 40 lbs [18 kg]
Weight (With Exhaust Only Defrost)			
Net core weight maximum			
Polypropylene	148 lbs [67 kg]	n/a	186 lbs [85 kg]
Aluminum	155 lbs [70 kg]	n/a	196 lbs [89 kg]
HM	159 lbs [72 kg]	n/a	203 lbs [92 kg]
Shipping weight	Add 40 lbs [18 kg]	n/a	Add 40 lbs [18 kg]
Shipping Dimensions (L x W x H)	40" x 32" x 32" [1,016 x 813 x 813 mm]	26" x 54" x 46" [660 x 1,372 x 1,168 mm]	38" x 44" x 32" [965 x 1,117 x 813 mm]

Note:

1 – Available as accessory on supply only, in addition to washable foam filter

Appendix B: Dimensional Drawings

Figure B1: HRV600i unit dimensional drawing (with exhaust only defrost)

Notes:
 Dimensions in [] are millimeters.
 ⬇ Center of gravity
 ➔ Direction of airflow

A minimum of 15.000" [381] clearance from any obstruction is required for removal of heat recovery cores, fans, etc. This model has a damper located on the outdoor intake connection. This damper will close during a frost control cycle or when the unit is placed in the 'Off' position with power maintained to the unit. This damper is not designed as a backdraft damper and will remain open if power is disconnected from the unit for any reason.

Poly Core			Aluminum Core			HM Core		
PTS	LBS	Kg	PTS	LBS	Kg	PTS	LBS	Kg
A	38	17	A	40	18	A	41	19
B	25	11	B	26	12	B	27	12
C	52	24	C	55	25	C	56	25
D	33	15	D	34	15	D	35	16
TOTAL	148	67	TOTAL	155	70	TOTAL	159	72

Connection Table		Connection Sizes	
(A)	Line voltage in	(A)	14 gauge wire nut
(B)	Condensate drain fitting (2x)	(B)	3/4" MPT

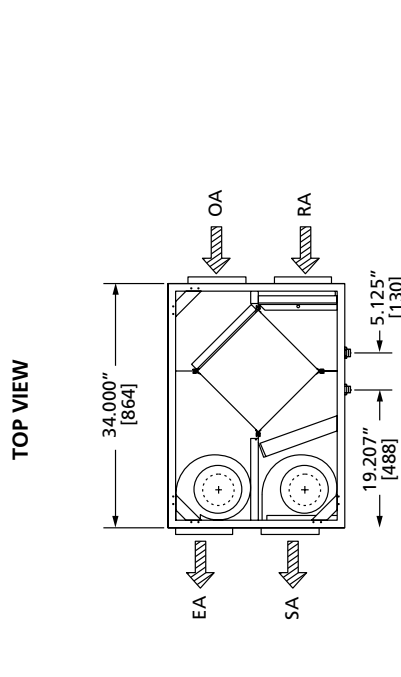
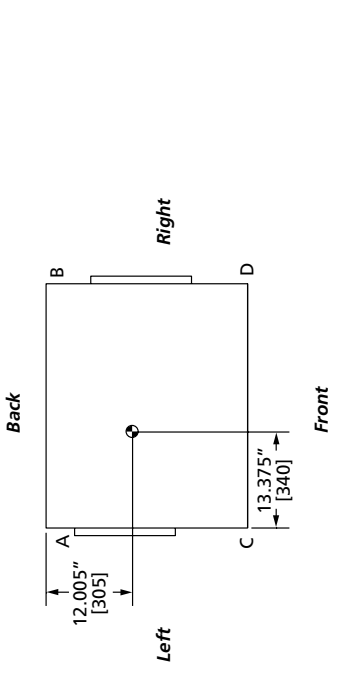

Note: For units with the reversed door option, interior components will appear as a mirror image of the above diagram.

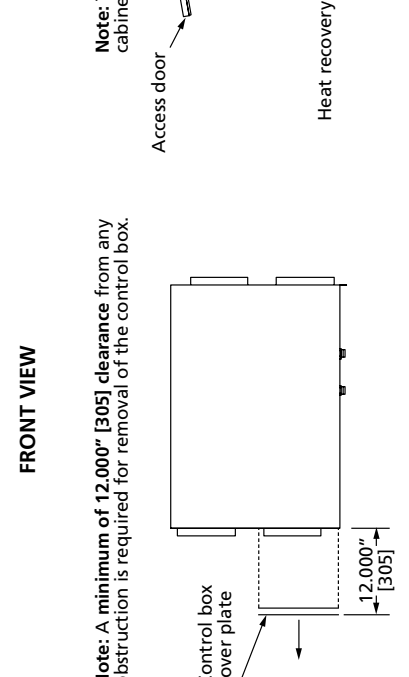

Note: A minimum of 12.000" [305] clearance from any obstruction is required for removal of the control box.

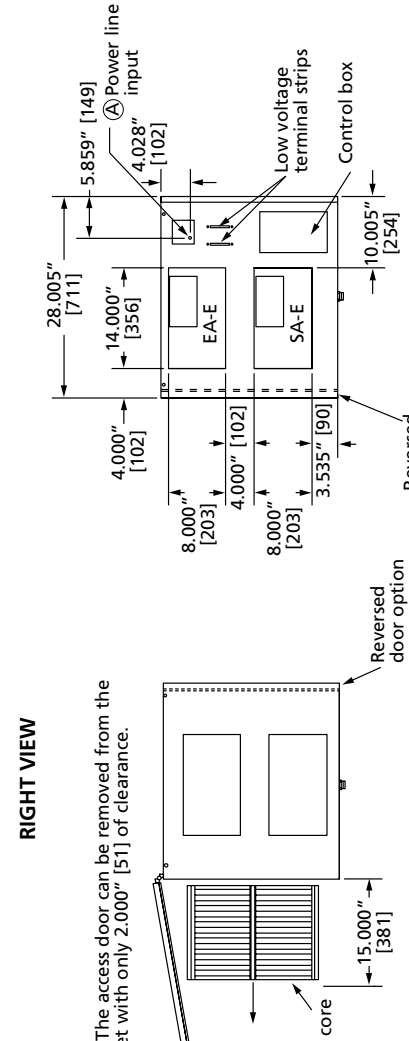

Note: The access door can be removed from the cabinet with only 2.000" [51] of clearance.

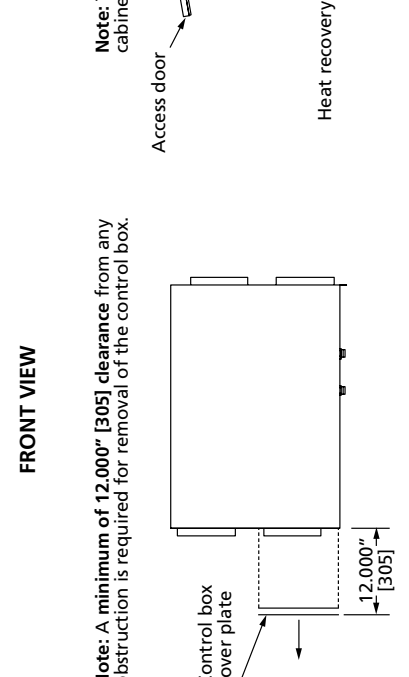

Note: The access door can be removed from the cabinet with only 2.000" [51] of clearance.



Figure B2: HRV600i unit dimensional drawing (with recirculation defrost)

Notes:
 Dimensions in [] are millimeters.
 A minimum of 15,000" [381] clearance from any obstruction is required for removal of heat recovery cores, fans, etc.

HRV600i (with recirculation defrost)		Connection Table	
Poly core	197 lbs [90 kg]	Line voltage in	14 gauge wire nut
Aluminum core	204 lbs [93 kg]	Condensate drain fitting (2x)	3/4" MPT
HMI core	208 lbs [95 kg]		

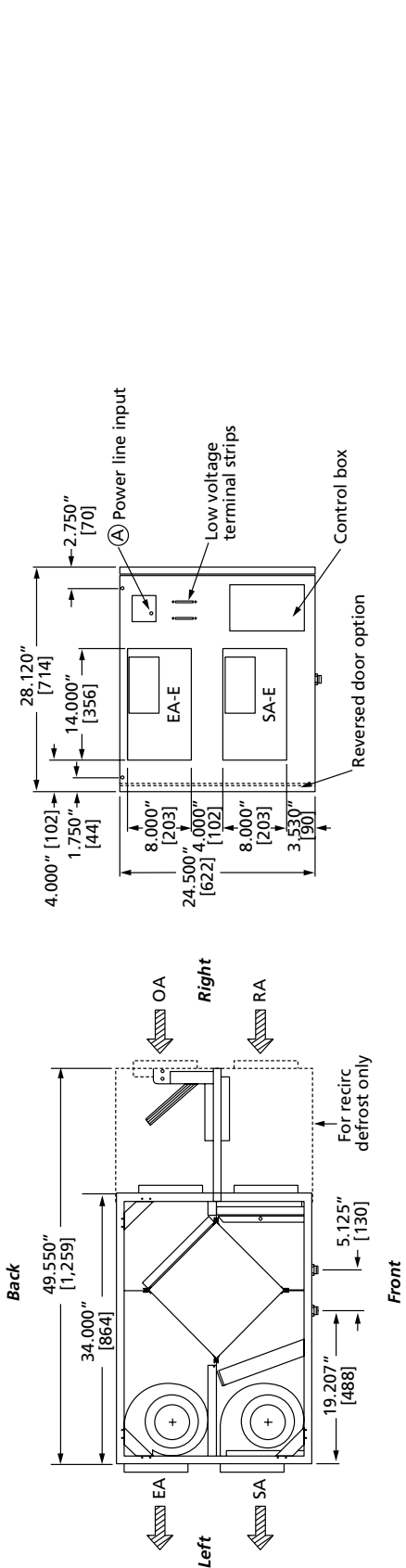

Note: For units with the reversed door option, interior components will appear as a mirror image of the above diagram.

LEFT VIEW

Note: The access door can be removed from cabinet with only 2,000" [51] of clearance.

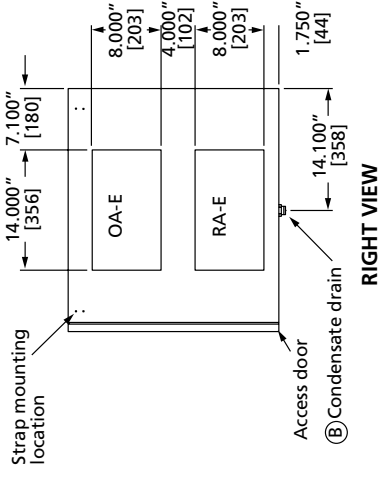

FRONT VIEW

Note: A minimum of 12,000" [305] clearance from any obstruction is required for removal of the control box.

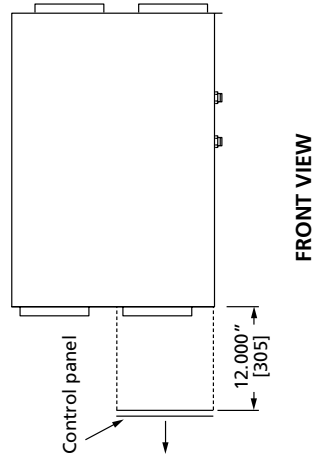

RIGHT VIEW

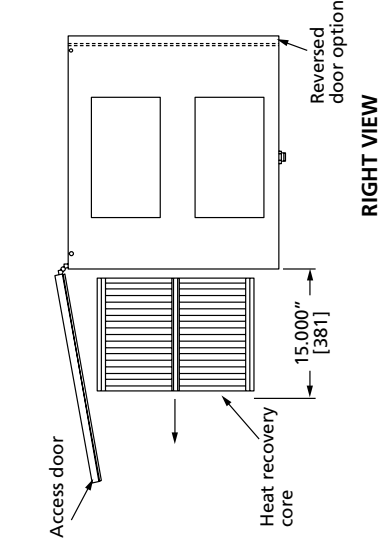
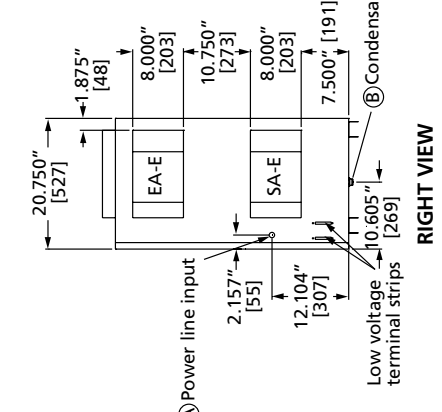
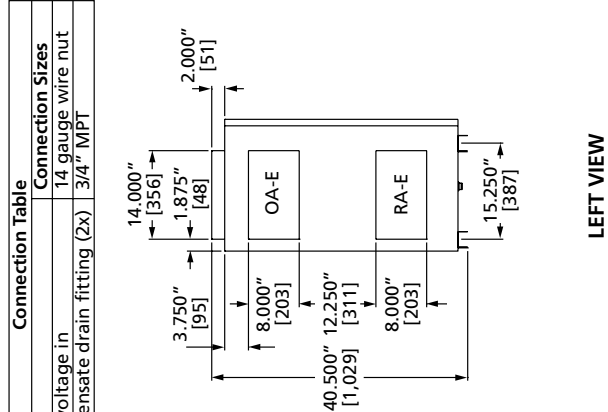
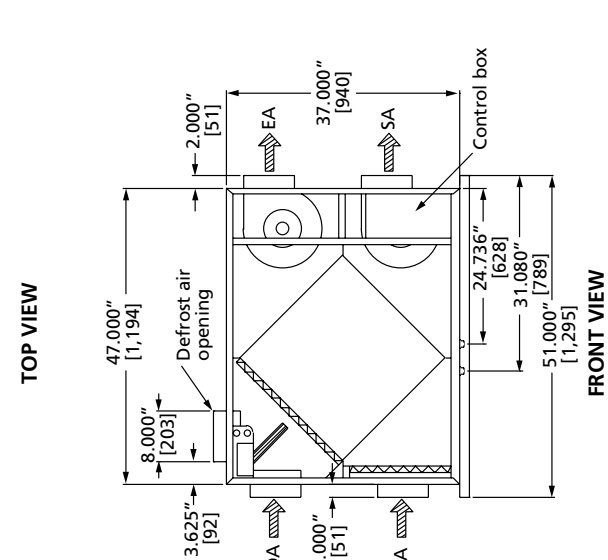
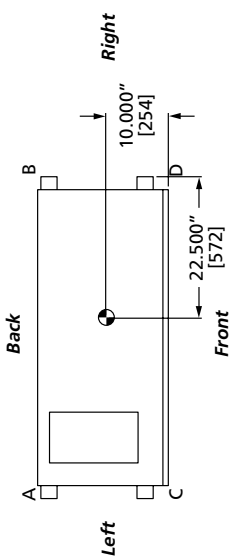

Figure B3: HRV700i unit dimensional drawing

Notes:
 Dimensions in [] are millimeters.
 ● Center of gravity
 ⇨ Direction of airflow
 A minimum of 21,000" [533] clearance from any obstruction is required for removal of heat recovery cores, fans and control box access.
 A minimum of 12,000" [305] clearance from any obstruction is required for power hook-up, low voltage remote connection and control panel access.
 Air is drawn in to the defrost air opening on top of the unit for recirculation defrost from the space or room in which the unit is mounted. If this air is not suitable for supply air or if a negative pressure is created and is not acceptable, then the defrost air opening should be ducted to a branch from the return air duct or from a suitable space.

PTS	LBS	Kg	Connection Table	Connection Sizes
A	34	15	14 gauge wire in	3/4" MPT
B	67	30	Condensate drain fitting (2x)	3/4" MPT
C	36	16		
D	74	34		
TOTAL	211	95		



Note: The access door can be removed from cabinet with only 2,000" [51] of clearance.

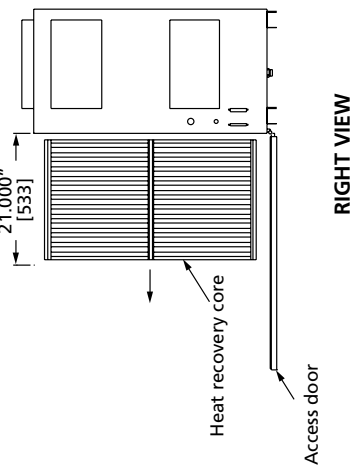
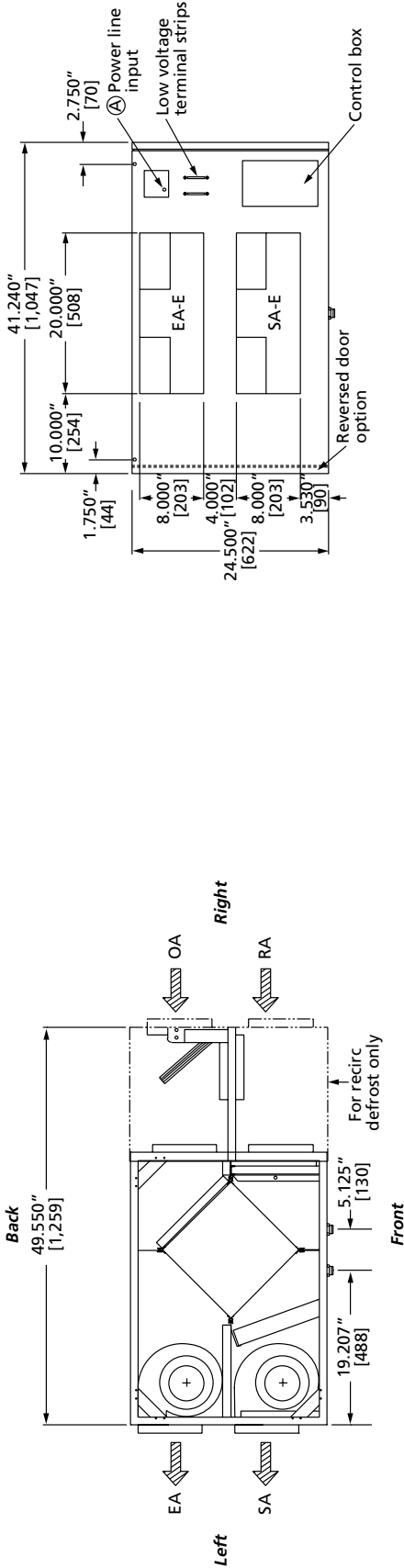

Figure B5: HRV1200i unit dimensional drawing (with recirculation defrost)

Notes:
 Dimensions in [] are millimeters
 A minimum of 15.000" [381] clearance from any obstruction is required for removal of heat recovery cores, fans, etc.

HRV1200i (with recirculation defrost)	
Poly core	247 lbs [112 kg]
Aluminum core	257 lbs [117 kg]
HM core	264 lbs [120 kg]

Connection Table	
Line voltage in	14 gauge wire nut
Condensate drain fitting (2x)	3/4" MPT



Note: For units with the reversed door option, interior components will appear as a mirror image of the above diagram.

FRONT VIEW

Note: A minimum of 12.000" [305] clearance from any obstruction is required for removal of the control box.

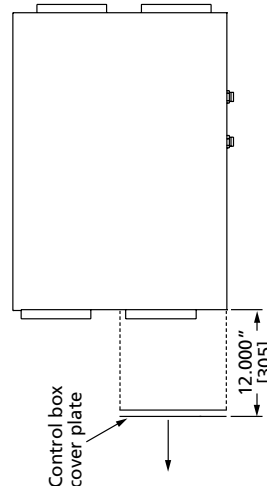

FRONT VIEW

Note: The access door can be removed from cabinet with only 2.000" [51] of clearance.

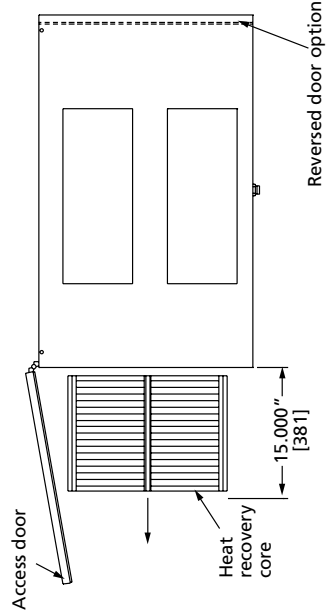

RIGHT VIEW

LEFT VIEW

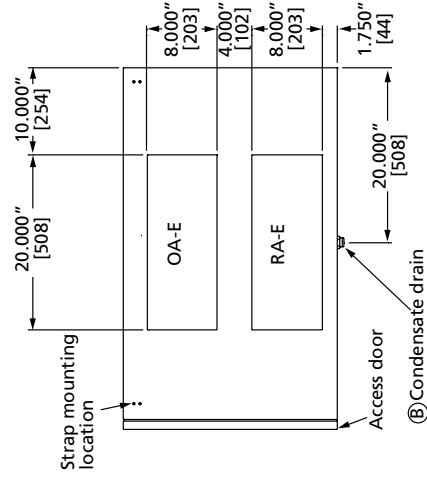

RIGHT VIEW

Appendix C: Flow Measuring Station and Balancing Damper Positions

Figure C1: HRV600i and HRV1200i flow measuring station and balancing damper positions

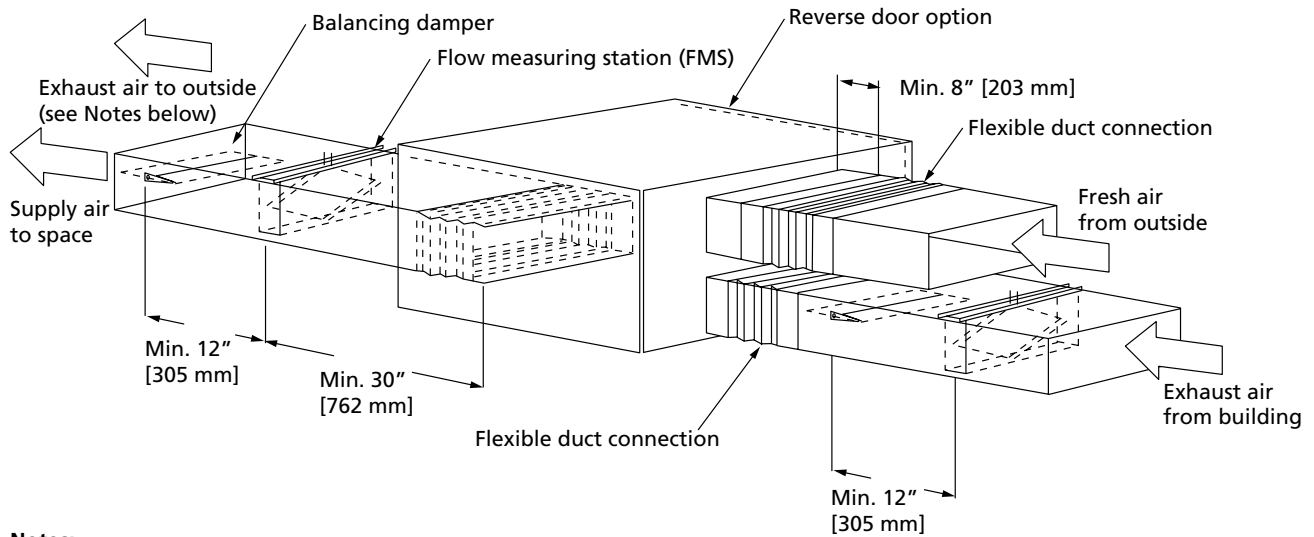

Notes:

1. The 'exhaust air to outside' duct is above the 'supply air to space' duct.
2. Straight duct sections minimum of 30" [762 mm] are required on supply to building and exhaust from the building to achieve good airflow performance.
3. Flexible duct connections, balancing damper and flow measuring stations are supplied and installed by others.

Figure C2: HRV700i flow measuring station and balancing damper positions

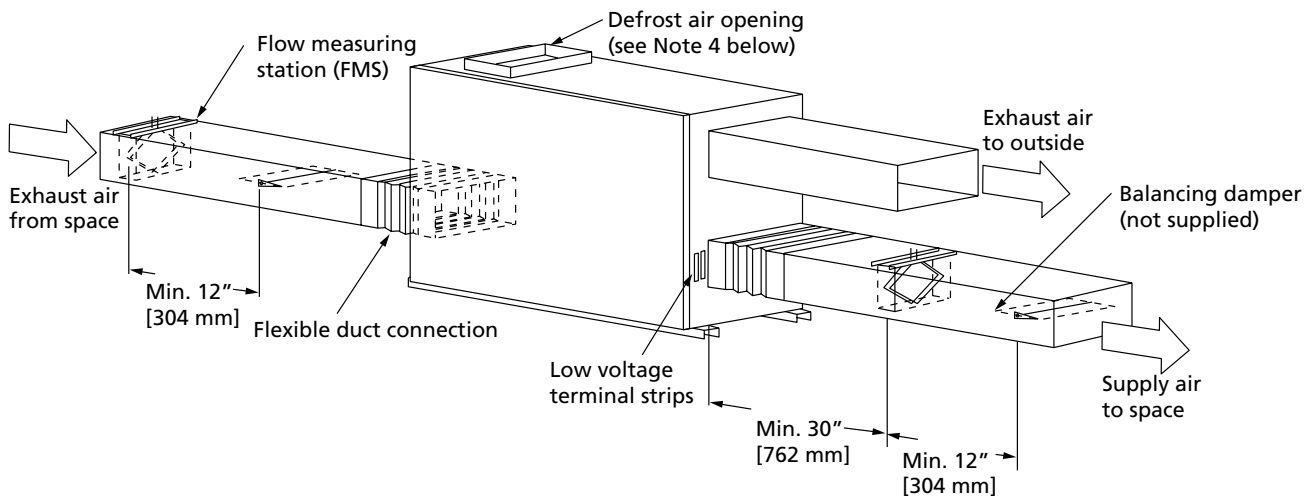

Notes:

1. The 'fresh air from outside' duct is above the 'exhaust air from space' duct.
2. Straight duct sections minimum of 30" [762 mm] are required on supply to building and exhaust from the building to achieve good airflow performance.
3. Flexible duct connections, balancing damper and flow measuring stations are supplied and installed by others.
4. Air is drawn in to the defrost air opening on top of the unit for recirculation defrost from the space or room in which the unit is mounted. If this air is not suitable for supply air or if a negative pressure is created and is not acceptable, then the defrost air opening should be ducted to a branch from the return air duct or from a suitable space.

Appendix D: Drain Connections

Figure D1: HRV600i and HRV1200i drain connections

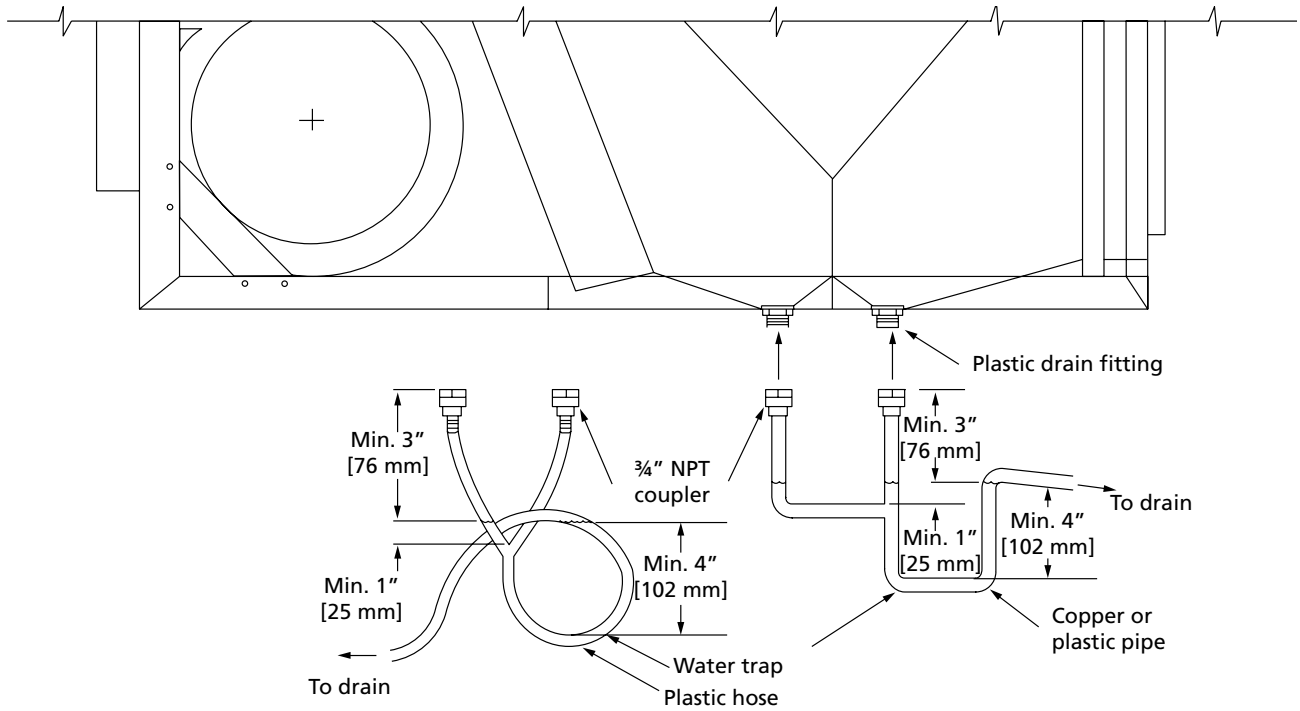

Notes:

1. All hose, pipe and couplers to be supplied by others.
2. Slope drain lines minimum 1/4" per foot.

Figure D2: HRV700i drain connections

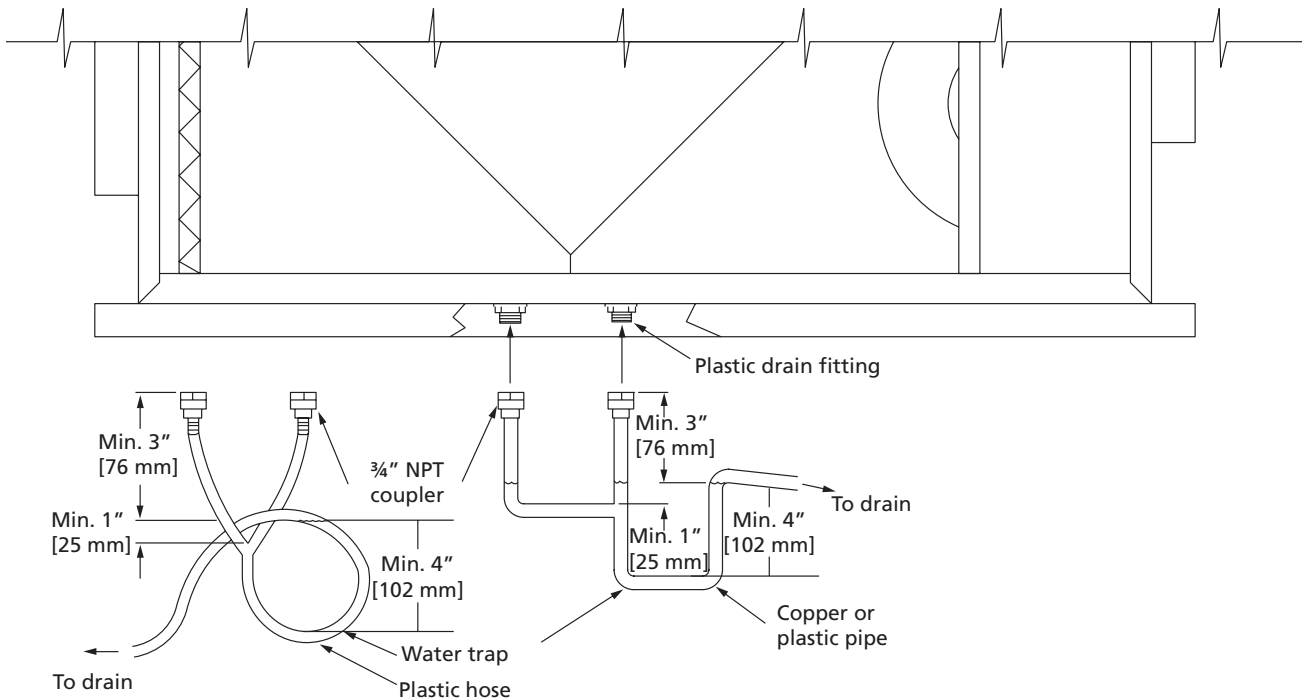

Notes:

1. All hose, pipe and couplers to be supplied by others.
2. Slope drain lines minimum 1/4" per foot.

Appendix E: Mounting Diagrams

Figure E1: HRV600i and HRV1200i mounting

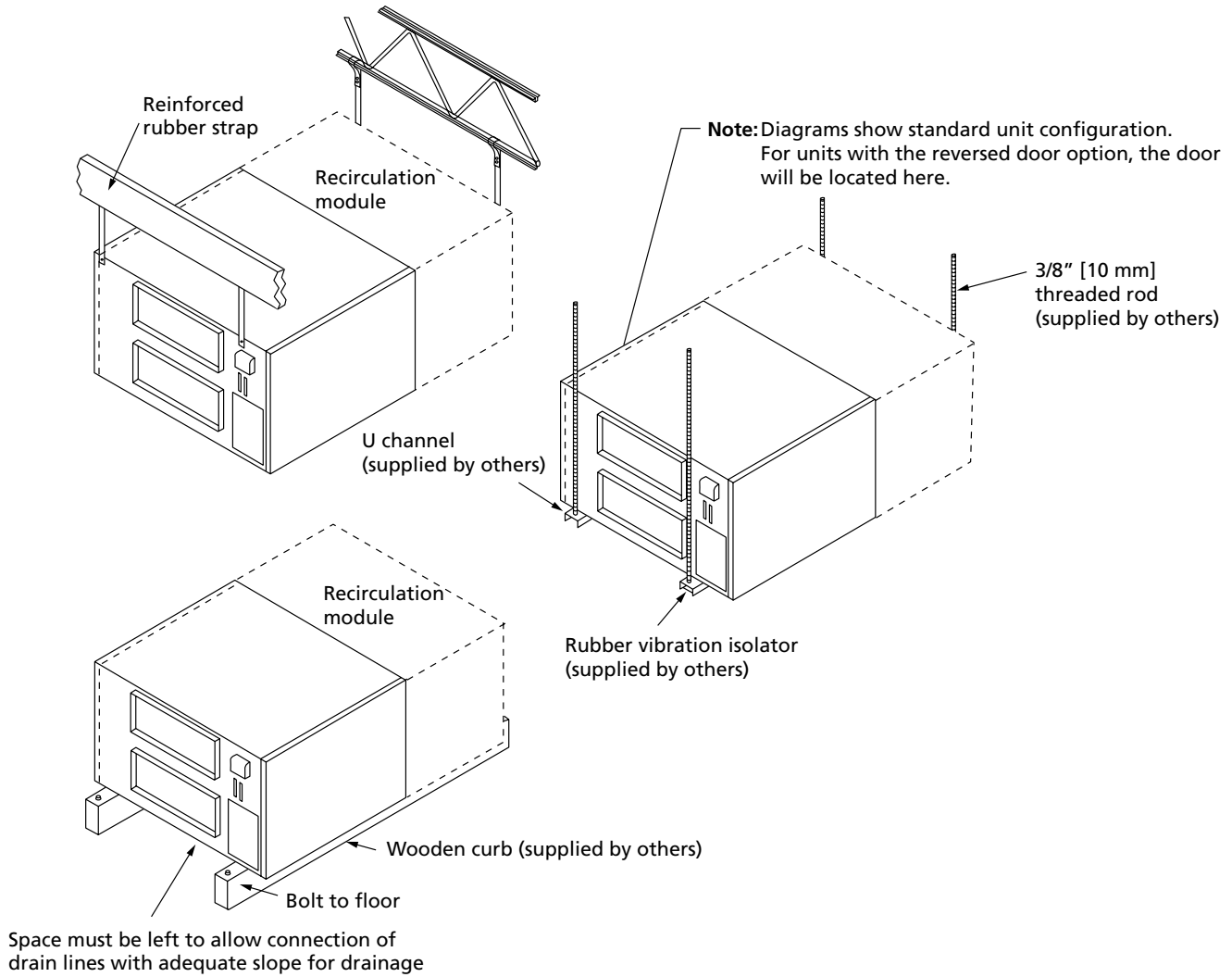
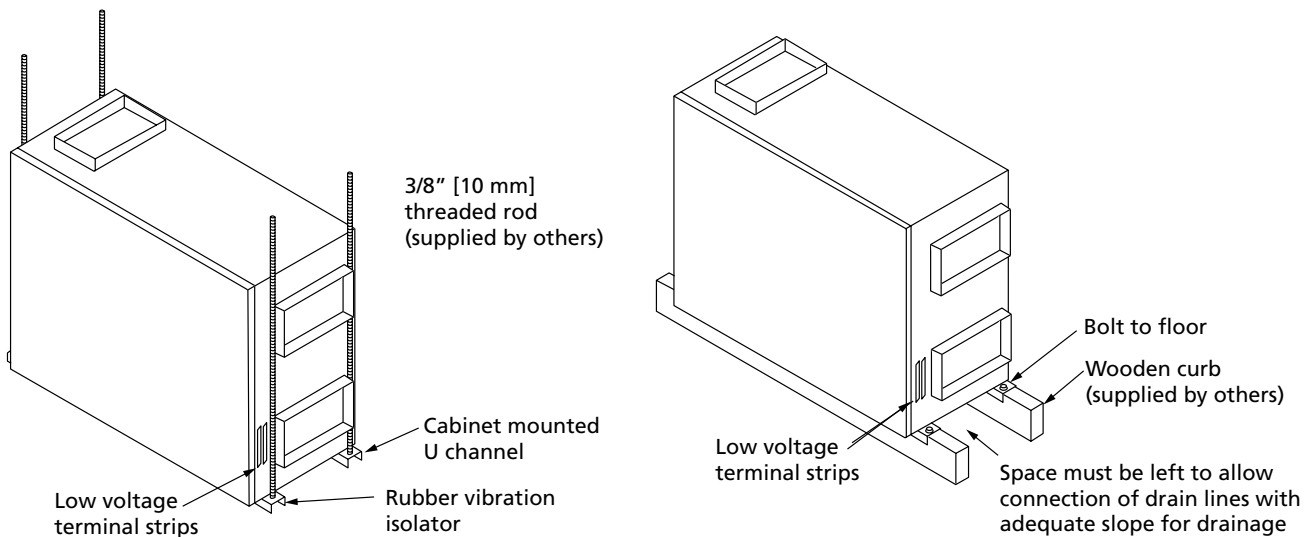

Figure E2: HRV700i mounting



Appendix F: Terminal Control Diagrams

Wall Control Connection

Three types of remote wall controls are available:

1. Standard wall control with fan switch and dehumidistat control.
2. Xtra wall control with fan mode selection, dehumidistat control and maintenance indicator.
3. Aqua Air wall control with fan mode selection, dehumidistat control and high speed recirculation mode.

The remote wall controls work with the integrated electronic controls within the unit to control ventilation sequences. Each wall control has different features and requires four-wire connection to the unit as shown below. Without the wall control, fans can be operated with a remote fan switch as shown in [Remote Fan Control](#).

IMPORTANT

All controls accessories (ex. night setback timer, CO₂ controller, enthalpy controller or smoke detector) intended to provide a contact closure for occupancy control across terminals 3 and 4 (left side) cannot be used in conjunction with the Xtra or Aqua Air wall controls.

If a wall control is required in addition to any of these options, only the standard wall control may be used. Without these options, a factory installed jumper across terminals 3 and 4 (left side) must be installed.

Figure F1: Wall control connection

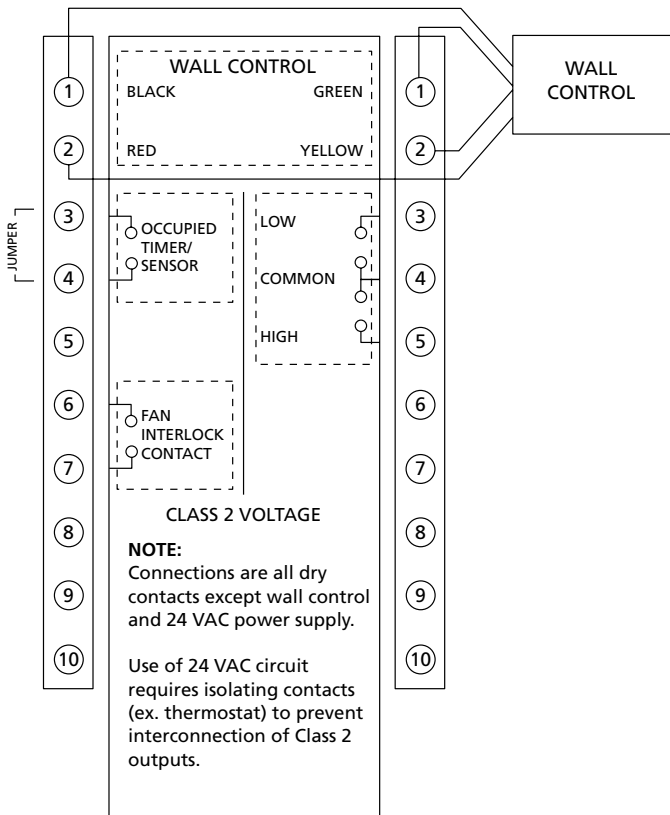

Occupied Timer/Sensor Connection

Occupancy control is achieved by connection to the terminal interface shown below. These terminals require a dry contact which could be provided by a number of types of controls such as a timer, light sensor, occupancy sensor, Building Management System or other. The unit will not operate unless these contacts are closed!

The illustration below shows a factory installed jumper and programmable timer option.

IMPORTANT

All controls accessories (ex. night setback timer, CO₂ controller, enthalpy controller or smoke detector) intended to provide a contact closure for occupancy control across terminals 3 and 4 (left side) cannot be used in conjunction with the Xtra or Aqua Air wall controls.

If a wall control is required in addition to any of these options, only the standard wall control may be used. Without these options, a factory installed jumper across terminals 3 and 4 (left side) must be installed.

Figure F2: Occupied timer/sensor connection

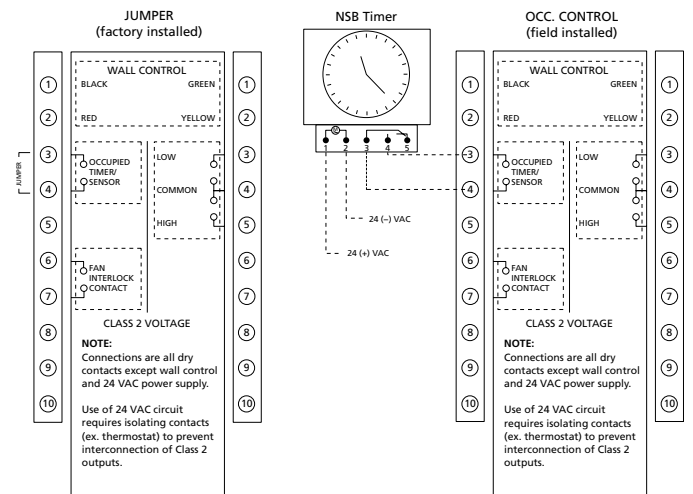

CO₂ Ventilation Control

HRVs can be controlled by a CO₂ controller that can be connected to fan control Low–Com–High. As the CO₂ levels exceed acceptable limits, the dry contact across High–Com is closed, raising high speed fan ventilation.

Figure F3: CO₂ ventilation control

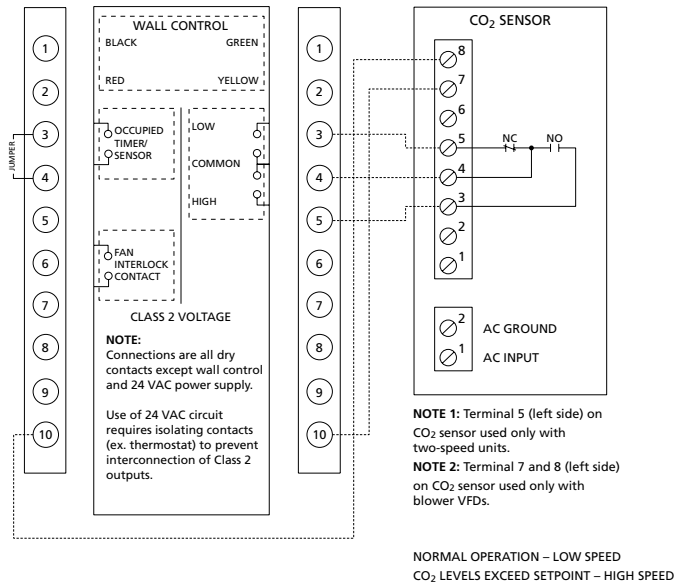

Remote Fan Control

Remote fan control can be achieved by connecting dry contact controls to the terminal interface at terminals labeled: Low–Com–High. These controls could be the following: SPDT switch, dehumidistat, CO₂ sensor, light sensor, timer, building management system, etc. The illustration below represents a switch connected to the unit.

CAUTION

Do not use a wall control and remote fan switch at the same time. Damage to the unit may occur.

Figure F4: Remote fan control

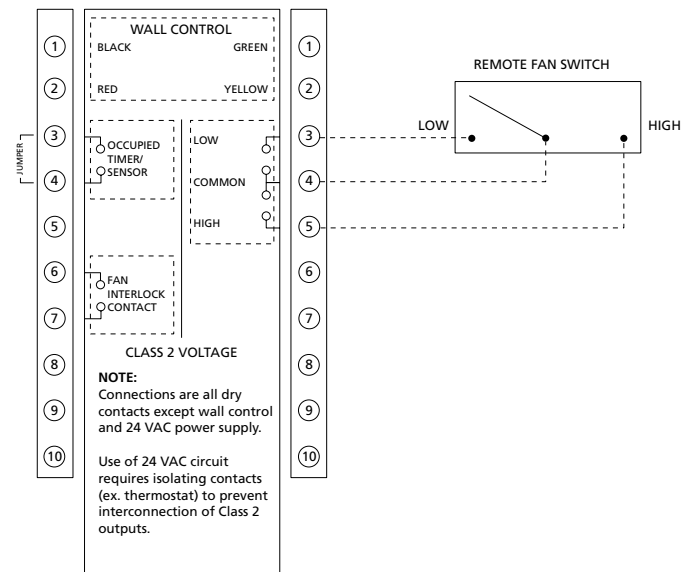

Smoke Detector

Locate in a normally occupied area of premises. Recommended for compliance to NFPA-90A and IMC code 606.

HRVs can be equipped with a duct mount smoke detector which will monitor the air when passing through the duct system into the HRV. When sufficient smoke is detected, an alarm condition is activated. By connecting the occupied timer/sensor contacts to the NC alarm auxiliary contacts on the duct sensor, an alarm condition will open the auxiliary contact and stop operation of the HRV.

Figure F5: Smoke detector

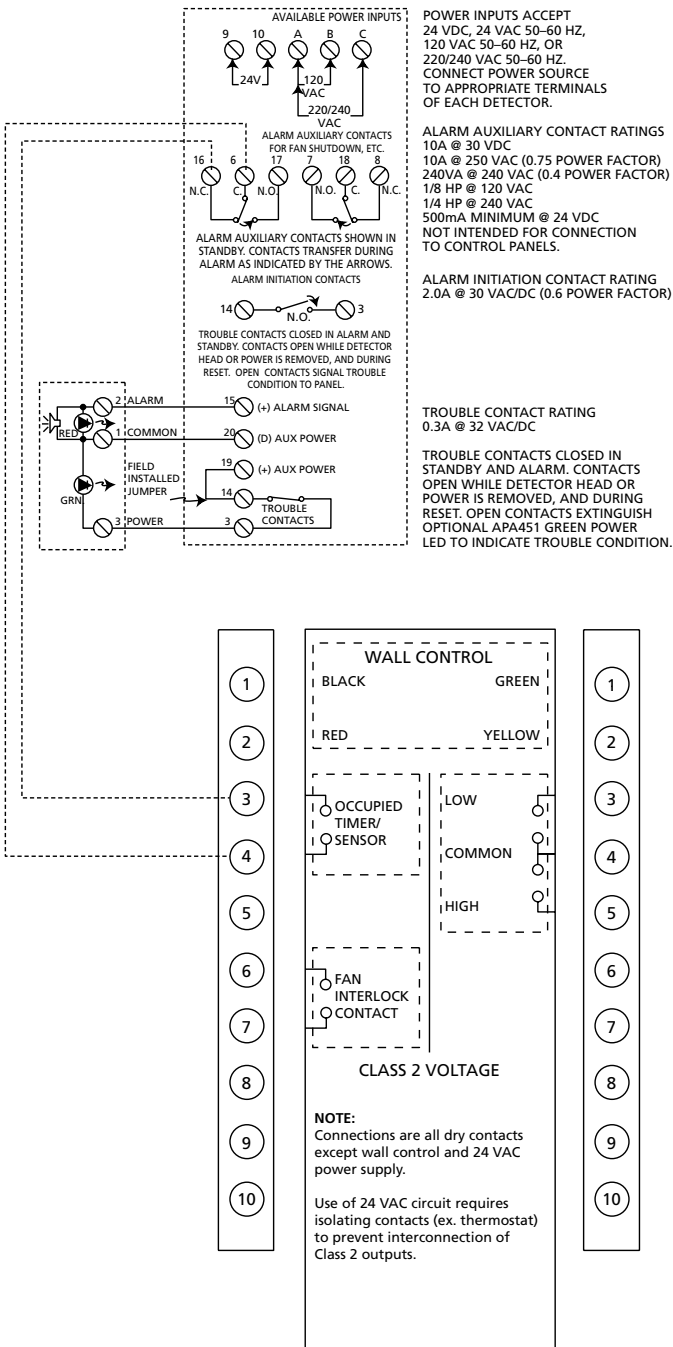

Appendix G: HRV600i, HRV700i and HRV1200i Start-up Form and Checklist

IMPORTANT

- Complete this form for each unit and email, fax or mail to Venmar CES immediately after start-up to validate warranty and to provide valuable information for personnel performing future maintenance or for factory assistance to address below.
- Read the Installation, Operation and Maintenance Instructions Manual before proceeding.
- Leave a copy of this report with the owner and at the unit for future reference and permanent record.
- To ensure proper operation of each unit qualified personnel should perform the start-up, complete the checklist and report.
- All units are factory run tested. Blowers and heat wheel are set up to run correct when power is connected. If any blower is running backwards disconnect power. If there is a negative pressure in the space and an exhaust discharge damper is missing or not closing properly, the fans with single-phase motors could be rotating in the wrong direction before the power is turned on and may not correct itself. Check the exhaust damper is present and dampers are closing properly or take corrective action before proceeding.

Venmar CES

1502 D Quebec Avenue
Saskatoon, Saskatchewan
Canada S7K 1V7
Phone: 1-866-4-VENMAR (1-866-483-6627)
Fax: (306) 651-6009

Unit Identification Information

Project: _____
Model Number: _____
Serial Number: _____
Tag: _____
Jobsite Contact: _____
Job Name: _____
Job Address: _____
Telephone: _____
Email: _____

Table G1: Pre Start-up Checklist

	Checklist Item	Yes	N/A
1	Is the electrical disconnect set to the 'Off' position?		
2	Have shipped loose parts, obstructive packaging, objects, tie downs on fans been removed?		
3	Are fans and motors rotating freely?		
4	Are air filters installed, clean or replaced?		
5	Are damper and linkages free of movement?		
6	Is ductwork connected and complete?		
7	Are condensate drain connections trapped, installed correctly and filled?		
8	Are all shipped loose or field supplied components correctly installed and wired?		
9	Has power supply and control wiring been inspected and approved by the Local Authorities?		
10	Have factory and field wiring connections been checked and tightened?		
11	Are all fuses properly installed in holders?		
12	Is voltage at the disconnect switch within 10% of nameplate?		
13	Are field piping and venting installation and connections for heating and cooling options completed and tested?		
14	Have all thermostat setpoints been checked and adjusted?		

Serial Number: _____

Table G2: Start-up Checklist

	Checklist Item	Yes	N/A
1	Before proceeding, complete the pre start-up checklist.		
2	For the unit to start when the disconnect switch is turned on a ventilation and fan speed call is required.		
	a. Is a ventilation call available from the remote wall control connection, occupied timer/sensor connection or BMS, whichever is used? See Appendix F for which terminal connections should be closed (contacts made) once power is connected. Circle which device is used.		
	b. Is either a low speed or high speed (if equipped) call available from the remote fan control, CO ₂ ventilation control or BMS, whichever is used? See Appendix F for which terminal connections should be closed (contacts made) once power is connected.		
	c. If 'a' and 'b' are not connected, start can be accomplished by using temporary external dry contacts or a jumper wire closing timer contacts 3 and 4 (left side) plus low speed contacts 3 and 4 (right side) or high speed contacts 4 and 5 (right side). Are temporary dry contacts or a jumper wire used for start?		
<p>⚠ WARNING</p> <p>Only low or high speed contacts must be closed at any one time using dry contacts/jumper wires, not both otherwise permanent damage to the motor and wiring will occur.</p> <p>Remote controls if installed and connected operate in conjunction with the dry contacts/jumper wires. When controlling units with remote controls, use extreme caution around moving mechanical components such as fans and motors as they can lead to severe personal injury.</p>			
3	Close all access panels or doors.		
4	Turn the unit disconnect switch to the 'On' position.		
	<p>IMPORTANT</p> <p>On initial power up, the unit will perform a system check and operate at high speed for five seconds.</p>		
5	Wait for blowers to run and then shut off unit's disconnect switch. Are the blowers and motors rotating in the correct direction? Note: If there is a negative pressure in the space and an exhaust discharge damper is missing or not closing properly the fans with single-phase motors could be rotating in the wrong direction before the power is turned on and may not correct itself. Check the exhaust damper is present and dampers are closing properly or take corrective action before proceeding.		
6	Are dampers operating properly?		
7	Close all access doors and turn the unit's disconnect to the 'On' position.		
8	Re-check the voltage at the disconnect switch against the nameplate with all blowers operating. If the voltage is not within 10% of rated have the condition corrected before continuing start-up.		
9	Check amperage draw to each motor on each phase against motor nameplate FLA. Do not allow the motor's amp draw to exceed the Motor Manufacturer's nameplate data. Excessive amp draw will cause premature failure of the motor and void the motor warranty. If significantly higher, adjust the manual balancing dampers in the ductwork (change the ductwork static pressure) to lower the amperage draw below the nameplate FLA.		
10	On the HRV600i and HRV1200i, there are three speed settings available with the controls, only two of which can be functional. The units are factory set to use the low and high speed taps on the blower motors. If additional airflow is required, the medium speed tap can be used instead of the low speed tap. See Appendix H for instructions on how to make this change.		
11	Check the fan operation on Low, Com and High. Use a wall control or the dry contact switching to run fan speeds as shown in Appendix F, Wall Control Connection .		
12	Check the operation of the control options and accessories provided with the unit. See Frost Control, Sequence of Operation and Appendix F for functional descriptions and further details.		
13	Check the setpoints on thermostats and controls; adjust and record changes as required.		
14	When unit has achieved steady state take measurements and complete readings section of Start-up Form for each operating cycle to verify all components are functioning properly.		

Start-up Readings

Serial Number: _____

- Allow unit to reach steady state before taking readings.
- Complete based on options included with the unit.

Table G3: Start-up Readings

Mode of Operation			Heating	Cooling		
Power supply	Nameplate voltage					
	Voltage at disconnect no motors					
Power supply with all loads connected	Voltage at full load					
	Supply fan	Full load amps				
		Amp draw				
		Overload amp setting				
		RPM				
	Exhaust fan	Full load amps				
		Amp draw				
		Overload amp setting				
RPM						
Airside	Airflow CFM	Supply				
		Exhaust				
	Temperature °F db/wb	Outdoor entering				
		Supply leaving				
		Return entering				
		Exhaust leaving				
	Static pressure inches w.c.	Outdoor duct				
		Supply entering				
		Supply duct				
		Return duct				
	Electric heating	Stage	1	2	3	4
		Amp draw – L1				
Amp draw – L2						
Amp draw – L3						

This unit has been checked out and started according with the above procedures and completed forms and is operating satisfactorily.

After 24 hours of satisfactory operation, shut down the unit and check all foundation bolts, fan set screws and terminals. Tighten where required.

Additional Comments:

Start-up

By: _____

Date: _____

Email: _____

Company Name: _____

Telephone: _____

Email to Tech Support (venmarservice@venmarces.com) or fax to 306-244-4221.

This page intentionally left blank.

Appendix H: Electrical Control Box and Wire Connections

Figure H1: HRV600i and HRV1200i electrical control box and wiring connections

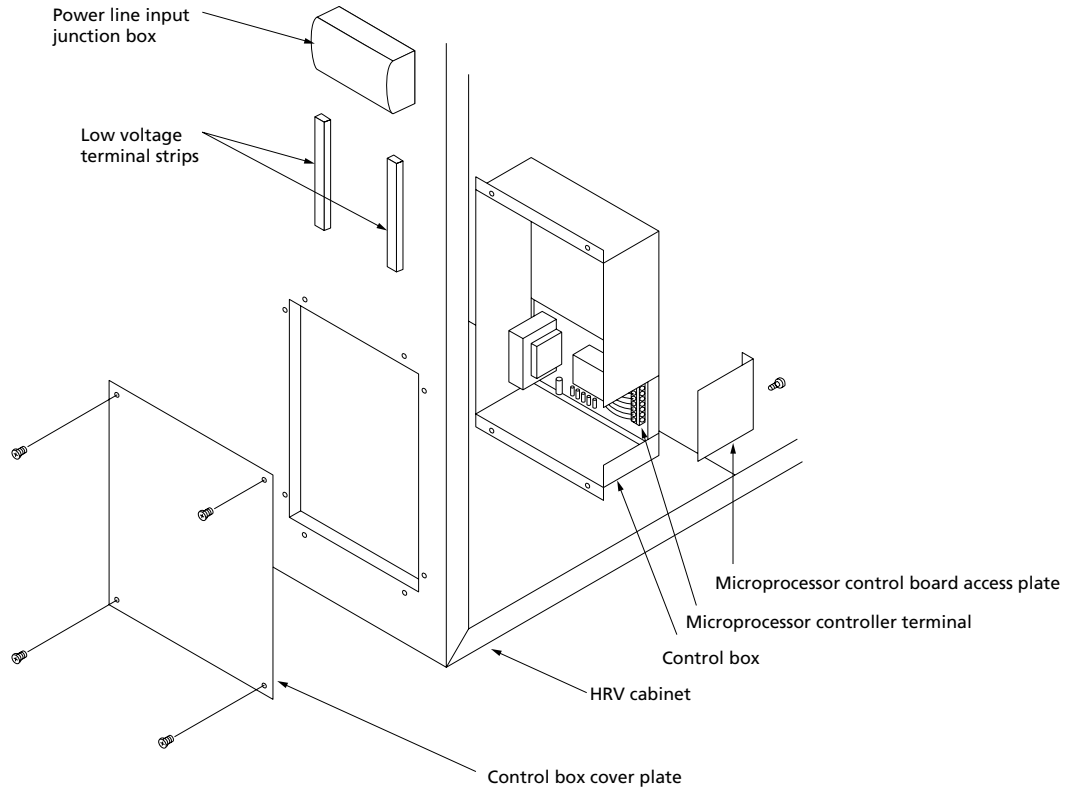
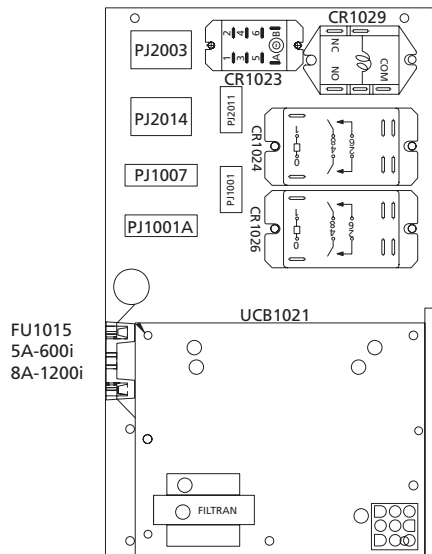
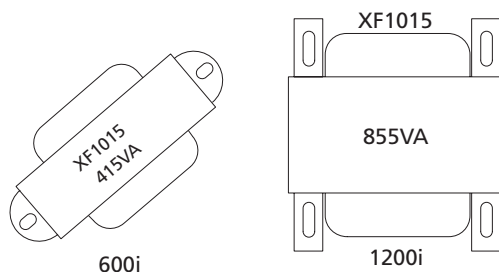

Figure H2: HRV600i and HRV1200i low speed setting wire connections



WARNING: Disconnect the main power source to the unit before changing low speed setting.



Note: Autotransformers (if equipped) are mounted on the back of the control box.

Appendix I: Components

Figure I1: HRV600i exhaust only defrost components

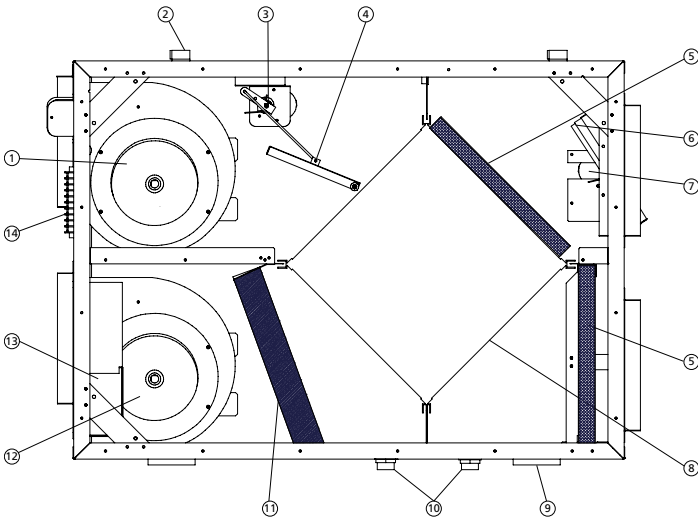

Item	Description	Part Number
1	Exhaust fan assembly – require 1 per unit	1808144
	Exhaust fan wheel – require 1 per unit	201586
	Exhaust fan motor – require 1 per unit	1808149
2	Hinge kit (male/female) – require 2 per unit	1607720
3	Core damper actuator assembly	1808139
4	Core/defrost damper	
5	Washable foam filter set (supply or exhaust airstream) – 2 per set	1608152
6	Supply damper	
7	Supply damper actuator assembly	1808138
8	Core poly UL kit – 2 per kit	1607781
	Core poly CSA kit – 2 per kit	1607782
	Core aluminum kit – 2 per kit	1607779
	Core HM kit – 2 per kit	1607785
9	Latch/keeper kit – require 2 per unit	1607852
10	Drain nipple – require 2 per unit	1607456
11	MEF filter set (supply airstream only) – 2 per set	1608155
12	Supply fan assembly – require 1 per unit	1808144
	Supply fan wheel – require 1 per unit	201586
	Supply fan motor – require 1 per unit	1808149
13	Control box	
14	Terminal strips	

Some unit components listed above are optional.
Consult the unit nomenclature for standard and optional components.

Figure I2: HRV600i recirculation defrost components

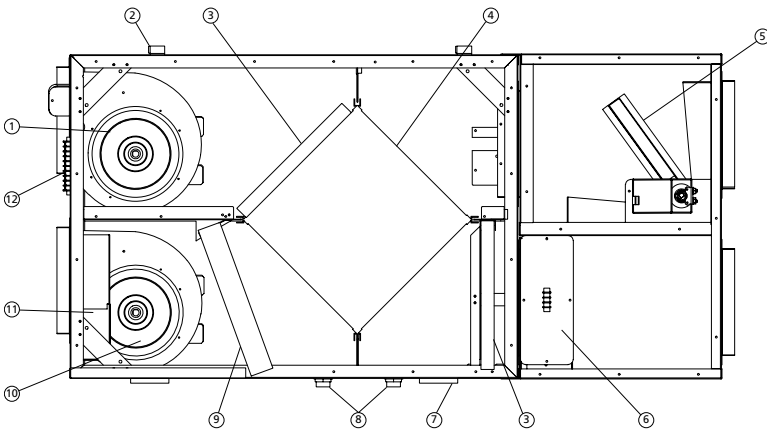

Item	Description	Part Number
1	Exhaust fan assembly – require 1 per unit	1808144
	Exhaust fan wheel – require 1 per unit	201586
	Exhaust fan motor – require 1 per unit	1808149
2	Hinge kit (male/female) – require 2 per unit	1607720
3	Washable foam filter set (supply or exhaust airstream) – 2 per set	1608152
4	Core poly UL kit – 2 per kit	1607781
	Core poly CSA kit – 2 per kit	1607782
	Core aluminum kit – 2 per kit	1607779
	Core HM kit – 2 per kit	1607785
5	Recirc defrost damper actuator	225855
6	Control box	
7	Latch/keeper kit – require 2 per unit	1607852
8	Drain nipple – require 2 per unit	1607456
9	MEF filter set (supply airstream only) – 2 per set	1608155
10	Supply fan assembly – require 1 per unit	1808144
	Supply fan wheel – require 1 per unit	201586
	Supply fan motor – require 1 per unit	1808149
11	Control box	
12	Terminal strips	

Some unit components listed above are optional.
Consult the unit nomenclature for standard and optional components.

Figure 13: HRV700i components

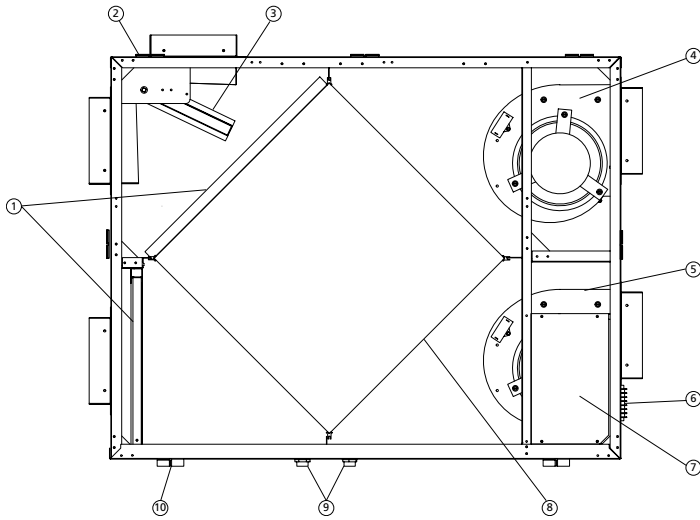

Item	Description	Part Number
1	Washable foam filter set (supply or exhaust airstream) – 2 per set	1608700
2	Latch/keeper kit – require 2 per unit	1607852
3	Recirc damper	1604178
	Actuator	225855
4	Exhaust fan assembly – require 1 per unit	1608120P
	Exhaust fan wheel – require 1 per unit	120200
	Exhaust fan motor – require 1 per unit	1604169
5	Supply fan assembly – require 1 per unit	1608120P
	Supply fan wheel – require 1 per unit	120200
	Supply fan motor – require 1 per unit	1604169
6	Terminal strip	
7	Control box	
8	Core poly UL – 1 per unit	1604190
	Core poly CSA – 1 per unit	1604156
9	Drain nipple – require 2 per unit	1670456
10	Hinge kit (male/female) – require 2 per unit	1607720

Some unit components listed above are optional.
Consult the unit nomenclature for standard and optional components.

Figure 14: HRV1200i exhaust only defrost components

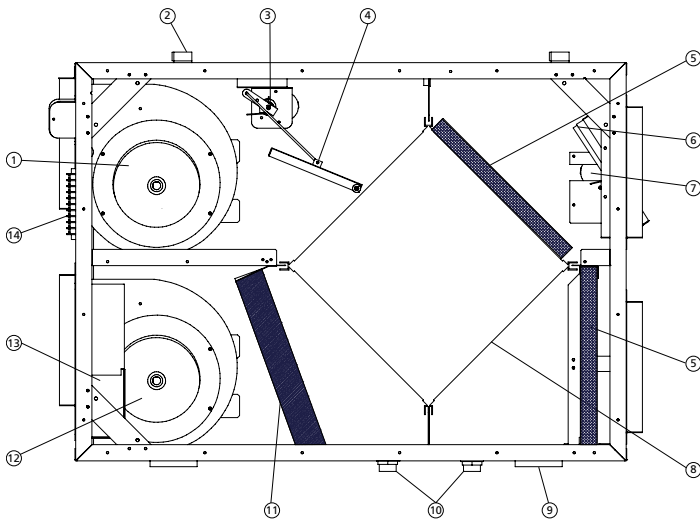

Item	Description	Part Number
1	Exhaust fan assembly galvanized – require 2 per unit	1808148
	Exhaust fan assembly powder coated – require 2 per unit	1808148P
	Exhaust fan wheel – require 2 per unit	201586
	Exhaust fan motor – require 2 per unit	1808150
2	Hinge kit (male/female) – require 2 per unit	1607720
3	Core damper actuator assembly	1808139
4	Core/defrost damper	
5	Washable foam filter set (supply or exhaust airstream) – 3 per set	1608153
6	Supply damper	
7	Supply damper actuator assembly	1808138
8	Core poly UL kit – 3 per kit	1607783
	Core poly CSA kit – 3 per kit	1607784
	Core aluminum kit – 3 per kit	1607780
	Core HM kit – 3 per kit	1607787
9	Latch/keeper kit – require 2 per unit	1607852
10	Drain nipple – require 2 per unit	1607456
11	MEF filter set (supply airstream only) – 3 per set	1608156
12	Supply fan assembly galvanized – require 2 per unit	1808148
	Supply fan assembly powder coated – require 2 per unit	1808148P
	Supply fan wheel – require 2 per unit	201586
	Supply fan motor – require 2 per unit	1808150
13	Control box	
14	Terminal strips	

Some unit components listed above are optional.
Consult the unit nomenclature for standard and optional components.

Figure 15: HRV1200i recirculation defrost components

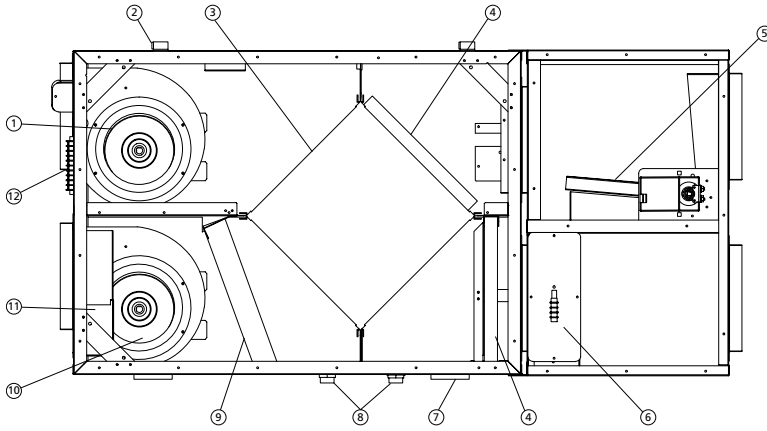

Item	Description	Part Number
1	Exhaust fan assembly galvanized – require 2 per unit	1808148
	Exhaust fan assembly powder coated – require 2 per unit	1808148P
	Exhaust fan wheel – require 2 per unit	201586
	Exhaust fan motor – require 2 per unit	1808150
2	Hinge kit (male/female) – require 2 per unit	1607720
3	Core poly UL kit – 3 per kit	1607783
	Core poly CSA kit – 3 per kit	1607784
	Core aluminum kit – 3 per kit	1607780
	Core HM kit – 3 per kit	1607787
4	Washable foam filter set (supply or exhaust airstream) – 3 per set	1608153
5	Recirc defrost damper actuator	225855
6	Control box	
7	Latch/keeper kit – require 2 per unit	1607852
8	Drain nipple – require 2 per unit	1607456
9	MEF filter set (supply airstream only) – 3 per set	1608156
10	Supply fan assembly galvanized – require 2 per unit	1808148
	Supply fan assembly powder coated – require 2 per unit	1808148P
	Supply fan wheel – require 2 per unit	201586
	Supply fan motor – require 2 per unit	1808150
11	Control box	
12	Terminal strips	

*Some unit components listed above are optional.
Consult the unit nomenclature for standard and optional components.*

Appendix J: Troubleshooting

Table J1: HRV600i, 700i and 1200i Troubleshooting

Symptoms	Possible Causes	Solutions
Inside air is too dry.	Over ventilation – speed setting too high.	Adjust speed setting.
	Dehumidistat setting too low.	Set dehumidistat control in a higher position (if applicable).
Persistent condensation on windows, walls, ceilings, etc.	Improper adjustment of dehumidistat control.	Adjust dehumidistat control knob to a lower setting.
	Improper ventilation rate.	Install a dehumidistat (option).
	Window frame is too cold or leaky.	Repair window frame.
Unit stops functioning.	Electrical supply interrupted.	Check the unit circuit breaker.
Air from supply diffusers too cold.	Imbalance of supply and exhaust air.	Check filters and heat exchangers for blockage. Check balance of airflows.
	Outdoor temperature very cold.	Install electric duct heater if necessary.
Unit makes annoying noise.	Blower wheel out of alignment.	Remove the motor/blower assembly and adjust blower wheel.
Heat exchanger freezing up.	Imbalance of supply and exhaust air.	Check filters and heat exchangers for blockage. Check balance of airflows.
	Frost control damper not functioning.	Check for operation of both frost control damper actuators.
Low exhaust airflow in winter season.	Heat exchanger flutes are positioned in the exhaust airstream.	Remove flat plate heat exchanger sections and re-position the flute side of the heat exchanger into the supply airstream.

Appendix K: Make-up Heat Requirements

Although the HRV600i, HRV700i and HRV1200i models have good efficiencies, the supply air could be colder than the ambient room air. It is possible to eliminate the discomfort associated with this temperature difference by installing an electric duct heater. This will temper the air before it is distributed throughout the building. The table below gives the heating requirements in kilowatts at different temperatures and airflows.

IMPORTANT

The data does not reflect a reduction in effectiveness due to frosting. Based on the standard air at: 0.075 lb/ft³ and Cp = 0.24 Btu/lbm°F [1.2 Kg/m³ and Cp = 1.0 KJ/Kg°C].

Table K1: Make-up Heat Requirements (kW) – HRV600i and HRV700i

Supply Air (CFM)	Supply Air (L/s)	Outdoor Air -40°F [-40°C]			Outdoor Air -22°F [-30°C]			Outdoor Air -4°F [-20°C]			Outdoor Air 14°F [-10°C]			Outdoor Air 32°F [0°C]		
		Desired Air Temperature			Desired Air Temperature			Desired Air Temperature			Desired Air Temperature			Desired Air Temperature		
		55°F [13°C]	68°F [20°C]	73°F [23°C]	55°F [13°C]	68°F [20°C]	73°F [23°C]	55°F [13°C]	68°F [20°C]	73°F [23°C]	55°F [13°C]	68°F [20°C]	73°F [23°C]	55°F [13°C]	68°F [20°C]	73°F [23°C]
700	330	7.4	10.4	11.5	5.6	8.6	9.7	3.9	6.8	8.0	2.1	5.1	6.2	0.3	3.3	4.4
650	307	6.6	9.4	10.5	5.0	7.8	8.9	3.4	6.2	7.3	1.8	4.6	5.6	0.2	3.0	4.0
600	283	5.9	8.5	9.4	4.5	7.0	8.0	3.0	5.6	6.5	1.6	4.1	5.1	0.1	2.7	3.7
550	259	5.2	7.6	8.5	3.9	6.3	7.2	2.6	5.0	5.9	1.3	3.7	4.6	0.1	2.4	3.3
500	236	4.0	6.1	7.0	3.0	5.1	5.9	1.9	4.0	4.9	0.9	3.0	3.8	—	1.9	2.7
450	212	3.0	4.9	5.6	2.1	4.0	4.8	1.3	3.2	3.9	0.4	2.3	3.1	—	1.5	2.2
400	189	2.2	3.9	4.6	1.5	3.2	3.9	0.9	2.5	3.2	0.2	1.9	2.5	—	1.2	1.8

Table K2: Make-up Heat Requirements (kW) – HRV1200i

Supply Air (CFM)	Supply Air (L/s)	Outdoor Air -40°F [-40°C]			Outdoor Air -22°F [-30°C]			Outdoor Air -4°F [-20°C]			Outdoor Air 14°F [-10°C]			Outdoor Air 32°F [0°C]		
		Desired Air Temperature			Desired Air Temperature			Desired Air Temperature			Desired Air Temperature			Desired Air Temperature		
		55°F [13°C]	68°F [20°C]	73°F [23°C]	55°F [13°C]	68°F [20°C]	73°F [23°C]	55°F [13°C]	68°F [20°C]	73°F [23°C]	55°F [13°C]	68°F [20°C]	73°F [23°C]	55°F [13°C]	68°F [20°C]	73°F [23°C]
1,250	590	14.6	19.9	21.9	11.2	16.5	18.5	7.8	13.1	15.2	4.4	9.7	11.8	1.0	6.3	8.4
1,200	566	13.5	18.6	20.6	10.4	15.5	17.4	7.2	12.3	14.3	4.0	9.1	11.1	0.8	5.9	7.9
1,150	542	12.6	17.4	19.3	9.6	14.5	16.4	6.6	11.5	13.4	3.6	8.5	10.4	0.7	5.5	7.4
1,100	675	11.2	15.9	17.7	8.5	13.2	15.0	5.8	10.5	12.3	3.1	7.7	9.6	0.4	5.0	6.8
1,050	495	10.7	15.2	16.9	8.1	12.6	14.3	5.5	10.0	11.7	2.9	7.4	9.1	0.4	4.8	6.5
1,000	472	9.9	14.1	15.7	7.4	11.7	13.3	5.0	9.3	10.9	2.6	6.9	8.5	0.2	4.4	6.1
900	425	8.5	12.4	13.8	6.4	10.2	11.7	4.3	8.1	9.6	2.2	6.0	7.5	0.1	3.9	5.4
800	377	7.0	10.4	11.7	5.2	8.6	9.9	3.4	6.8	8.2	1.7	5.0	6.4	—	3.3	4.6
700	330	5.0	8.1	9.3	3.7	6.7	7.9	2.3	5.3	6.5	0.9	3.9	5.1	—	2.5	3.7



info@venmarces.com
www.venmarces.com

Venmar CES has a policy of continuous improvement and reserves the right to change design and specifications without notice.

©2001 Venmar CES
VCES-HRV-IOM-1C (PN 206815)
September 2014