

United States
Department of
Agriculture

Forest Service

**Technology &
Development
Program**

2300 Recreation
August 1996
9623-2802-MTDC



Stock-Drawn Equipment for Trail Work



Stock-Drawn Equipment for Trail Work



Steve Didier, *Packer*
Lochsa Ranger District
Clearwater National Forest

Diane Herzberg
Mechanical Engineer

USDA Forest Service
Technology and Development Program
Missoula, Montana

3E32A14—Horse-Drawn Trail Plow

August 1996

The Forest Service, United States Department of Agriculture (USDA), has developed this information for the guidance of its employees, its contractors, and its cooperating Federal and State agencies, and is not responsible for the interpretation or use of this information by anyone except its own employees. The use of trade, firm, or corporation names in this document is for the information and convenience of the reader, and does not constitute an endorsement by the Department of any product or service to the exclusion of others that may be suitable.

The U.S. Department of Agriculture (USDA) prohibits discrimination in all its programs and activities on the basis of race, color, national origin, sex, religion, age, disability, political beliefs, sexual orientation, or marital or family status. (Not all prohibited bases apply to all programs.) Persons with disabilities who require alternative means for communication of program information (Braille, large print, audiotape, etc.) should contact USDA's TARGET Center at (202) 720-2600 (voice and TDD). To file a complaint of discrimination, write USDA, Director, Office of Civil Rights, Room 326-W, Whitten Building, 1400 Independence Avenue, SW, Washington, D.C. 20250-9410 or call (202) 720-5964 (voice and TDD). USDA is an equal opportunity provider and employer.

Contents

Introduction	1
Hillside Plow Designs	2
Vulcan	6
Chattanooga (International Harvester)	6
Oliver	7
Syracuse (John Deere)	7
Grading Equipment	8
Beatty Grader	9
Fremont Grader	10
Specialty Equipment Designs	11
MTDC Combination Plow and Grader	11
Trail Ace and Trail Scoop	12
Performance Testing	13
Results	15
Discussion of Results	16
Recommendations	17
Equipment Modifications	17
Operator Qualifications and Training	21
Sources	22

—Line drawings of the hillside plow and Beatty grader by Steve Didier, Jr.

Introduction

This project started as an investigation to find replacement parts for the stock-drawn hillside plows of yesteryear. Manufacturers no longer provide replacement parts for machines or implements that have been out of production for 50 years or more. The only sources for parts in the past were “bone yards” of implement dealers or salvage yards, or old-timers who knew the location of some old plows. The Amish, who still use horses as draft animals, have manufactured replacement parts for some old horse plows. In addition, they have built a couple of their own models similar to the 10-in (250-mm) Oliver hillside plow, using a similar cast plowshare.

Besides looking for replacement parts, the Missoula Technology and Development Center (MTDC) fabricated a couple of stock-drawn trail implements. The Center duplicated a grader initially developed and used on the Fremont National Forest’s Lakeview Ranger District. The Center also fabricated a copy of a combination plow and grader implement developed in the early 1970’s, MTDC drawing no. MEDC-529.

The purpose of this project was to:

- Locate manufacturers, sources, and suppliers of stock-drawn implements that could be used for trail tread maintenance and construction.
- Estimate production rate of the implement, (for instance, feet or miles of trails that can be covered in an 8-hr day).
- Assess skills required of equipment operators and how easy or hard the implement is to use.

This information would be obtained for the following implements:

- Vulcan hillside plow or similar plow
- Beatty grader
- Fremont trail grader
- MTDC combination plow and grader
- Trail Ace and Trail Scoop.

Hillside Plow Designs

The hillside plow is the traditional horse- or mule-drawn agricultural implement for plowing on steep ground (Figure 1). Hillside plows are also called turning plows. A latch allows the moldboard and shoe to rotate from right to left (Figure 2). Rotating the cutting part of the plow allows the operator to turn a hill of dirt to the downhill side of the trail bed, regardless of the plow's direction of travel.

Most designs have provisions for a draft adjustment range of several inches both vertically (Figure 3), and laterally (Figure 4). The better designs allow hillside (lateral) draft adjustment from the handles. The size of a plow refers to the width of the furrow it is capable of plowing. Plow sizes range from 5 in (130 mm) to 14 in (360 mm). Figure 5 shows the Chattanooga plow.

There are four basic styles of hillside plows. They differ in their availability and in their design. Effective hillside plows are designed with adjustments for vertical (down) draft and horizontal (hillside) draft. Plow handles should have adjustments to accommodate operators, whether they are short or tall. Plow handles should be made of wood rather than metal for comfort and safety. Wood absorbs vibrations and can flex.

A plow is only as good as its bottom. In hillside plows, the bottom includes the share and shoe, which is mounted on the body of the plow. The share and shoe provide bottom suction and hillside suction. This suction is created by the concavities of the plow's bottom. The easiest running plows are those with a fairly pronounced concavity. Bottom suction and hillside suction concavities are illustrated in Figures 6 to 13.

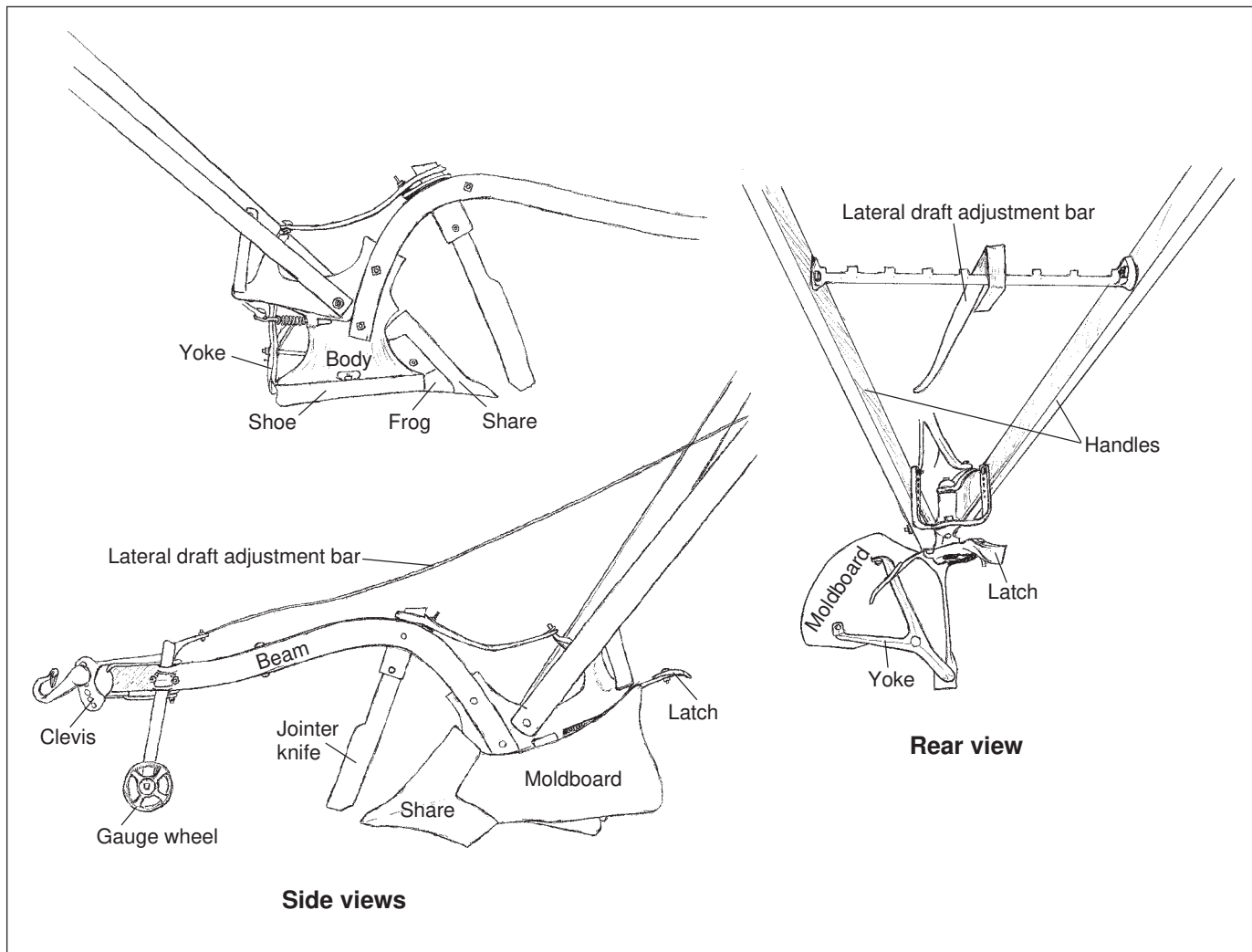

Figure 1—Line drawings of a plow and parts.



Figure 2—The latch on a hillside plow.



Figure 4—Lateral draft adjustment.



Figure 3—Vertical draft adjustment.

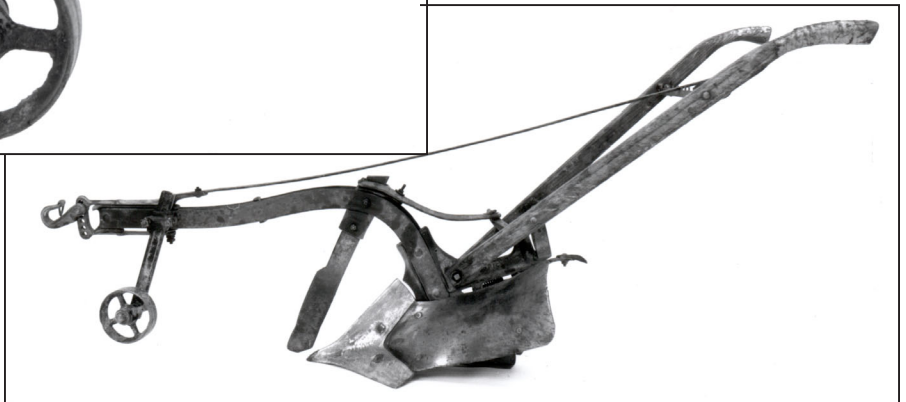

Figure 5—International Harvester's Chattanooga hillside plow.

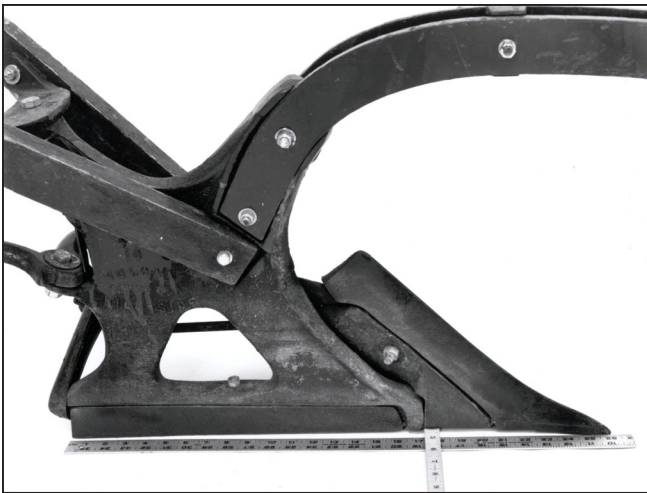

Figure 6—Vulcan plow showing about $1\frac{1}{2}$ inch of hillside suction.

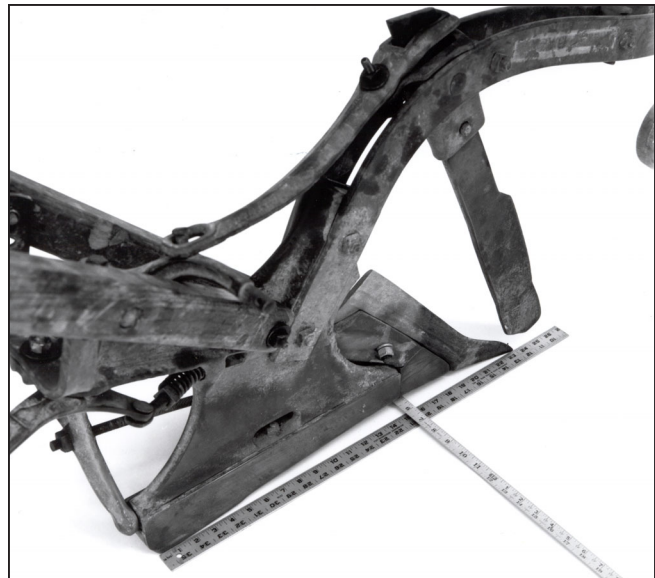

Figure 8—Chattanooga plow showing nearly 1 inch of hillside suction.

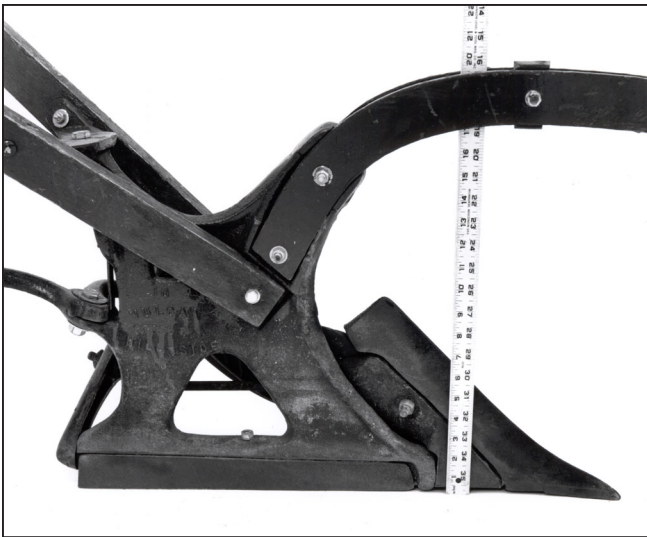

Figure 7—Vulcan plow showing about $1\frac{1}{4}$ inch of bottom suction.

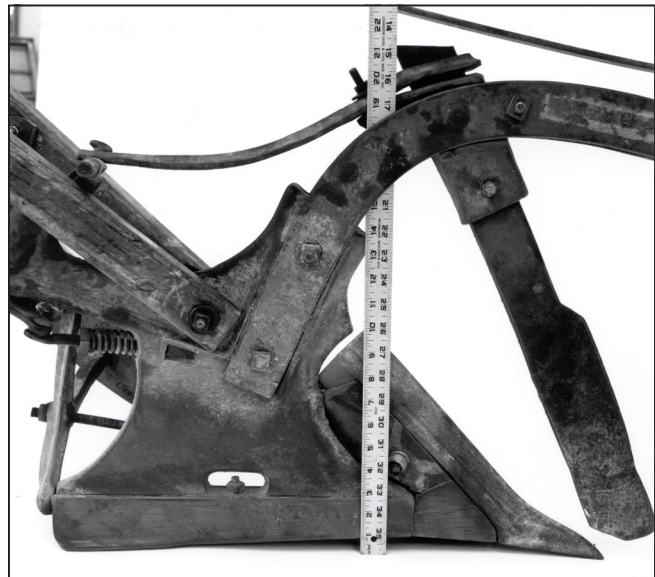

Figure 9—Chattanooga plow showing about $7\frac{1}{8}$ inch of bottom suction.

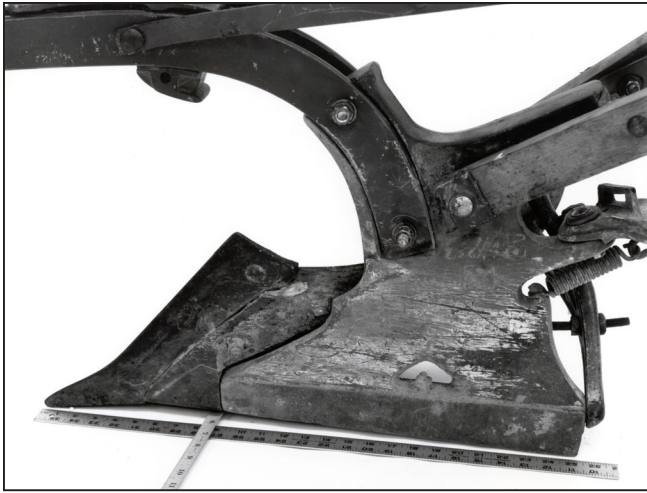

Figure 10—Oliver plow showing about $1\frac{1}{2}$ inch of hillside suction.



Figure 12—Syracuse plow showing about $\frac{7}{8}$ inch of hillside suction.

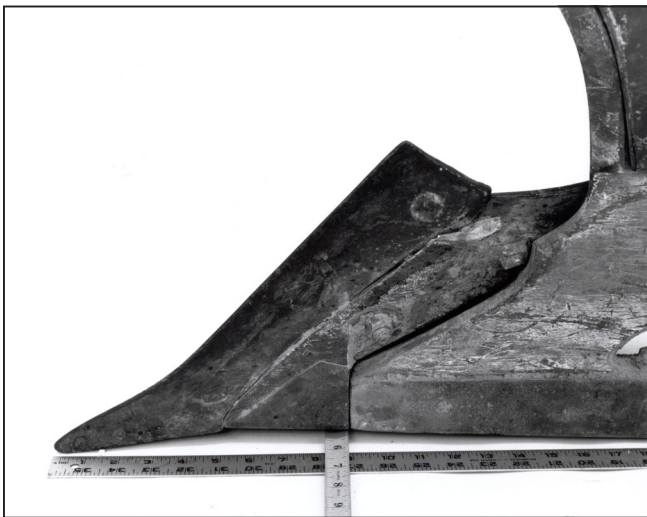

Figure 11—Oliver plow showing about $\frac{3}{4}$ inch of bottom suction.



Figure 13—Syracuse plow showing about $1\frac{1}{2}$ inch of bottom suction.

Vulcan

The Vulcan is a hillside or “two-way” plow (Figure 14). The Vulcan is the only style currently being manufactured in its entirety. They are produced by a foundry in Amish country. Delivery times run from 3 to 6 months. The current price is around \$400.

- Plow sizes range from 6 to 12 in (150 to 300 mm), and weigh 15 to 130 lb (7 to 59 kg).
- Jointer knife is not available.
- Gauge wheel is lightly mounted although the supports can be strengthened.
- Lateral (hillside) draft adjustment is provided by a sliding clevis and ring assembly available as an accessory.
- Latches are not adjustable, with no provision for wear.



Figure 14—Vulcan hillside plow.

Chattanooga (International Harvester)

The Chattanooga (International Harvester) plow is one of two types commonly used by the U.S. Department of Agriculture, Forest Service, in the 1940's and 1950's (Figure 15). Occasionally, a 10-in (250-mm) Chattanooga can still be found in bone yards, antique stores, or in stock-drawn implement dealers. Parts are also available from the Erb Plow Works in Sugar Creek, OH. Shares may be obtained from Dyko, Inc., of Spokane, WA. This plow, complete with single tree, weighs about 150 lb (68 kg). Set up for trail plowing, the plow will have the following:

- Jointer knife for slicing heavy sod and roots.
- Adjustable hillside (lateral) draft from the handles.
- Adjustable latch claws to prevent the plow share and moldboard from chattering.
- Gauge wheel for depth adjustment and easy running.



Figure 15—International Harvester's Chattanooga hillside plow.

Oliver

Oliver hillside plows, also set up for trail plowing, are similar to the Chattanooga in availability of complete plows and parts (Figure 16). The Oliver trail plow design has features similar to the Chattanooga:

- Jointer knife for slicing heavy sod and roots.
- Adjustable hillside (lateral) draft from the handles.
- Adjustable latch claws.
- Gauge wheels.

The weight of the 10-in (250-mm) plow, 150 lb (68 kg), is also comparable to the Chattanooga.



Figure 16—Oliver hillside plow.

Syracuse (John Deere)

Syracuse hillside plows made by John Deere are available in areas of the country where John Deere was the primary implement dealer in the first half of the century (Figure 17). These plows are generally 20 to 30 lb (9 to 14 kg) lighter than the Oliver and Chattanooga, and they do not have a jointer knife and gauge wheel. The hillside draft is also controlled at the handles on these plows. Syracuse plows were made in an assortment of sizes from 6 to 12 in (150 to 300 mm).



Figure 17—John Deere's Syracuse hillside plow.

Grading Equipment

Two types of stock-drawn graders are currently available to finish the trail tread (Figure 18).

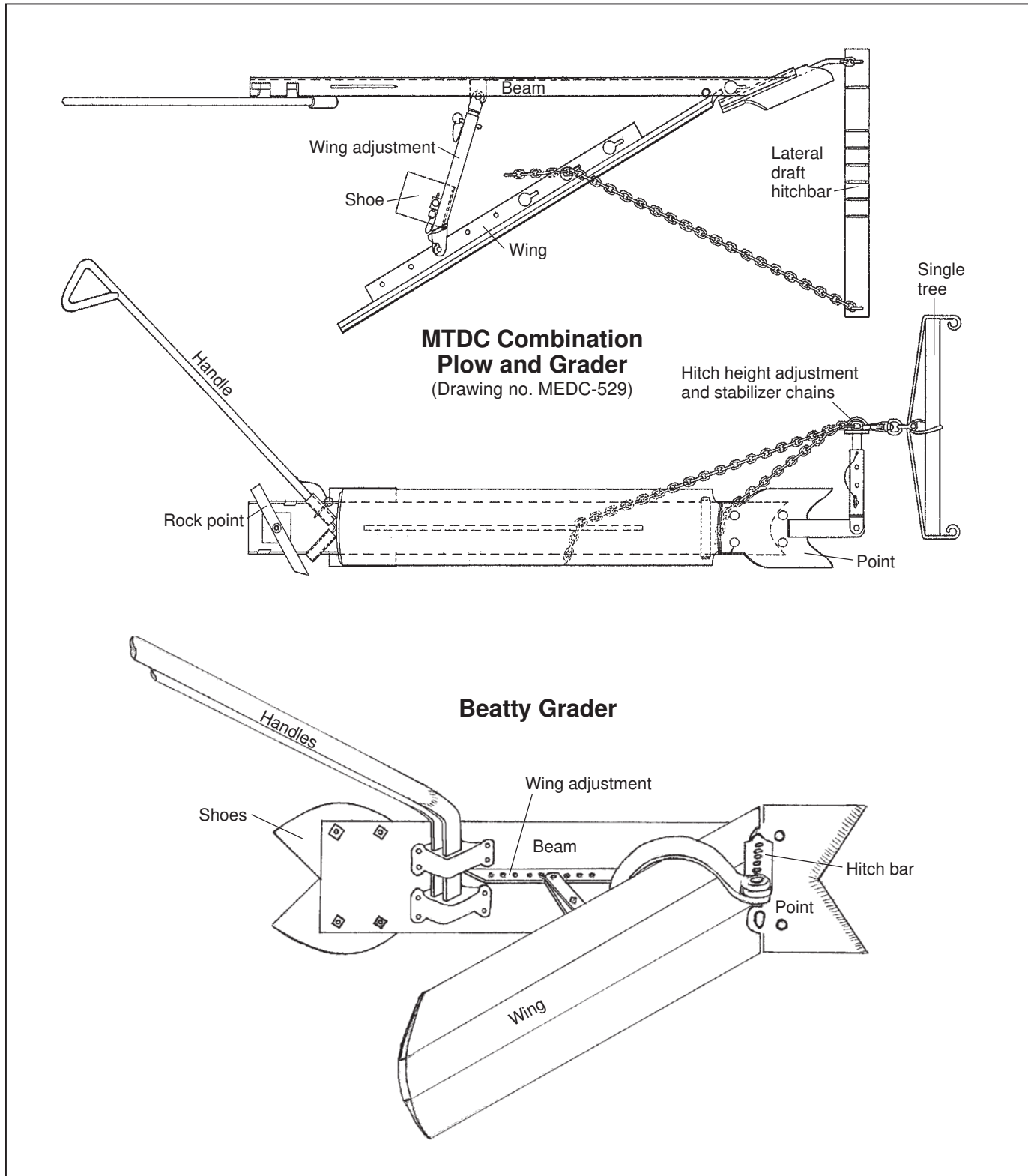

Figure 18—Line drawings of the MTDC combination plow and grader, and the Beatty trail grader.

Beatty Grader

The Beatty grader is a modified ditcher originally manufactured by General Machine in Spokane, WA (Figure 19). Although this manufacturer is no longer in business, Idaho Falls Foundry and Machine, in Idaho Falls, ID, has molds

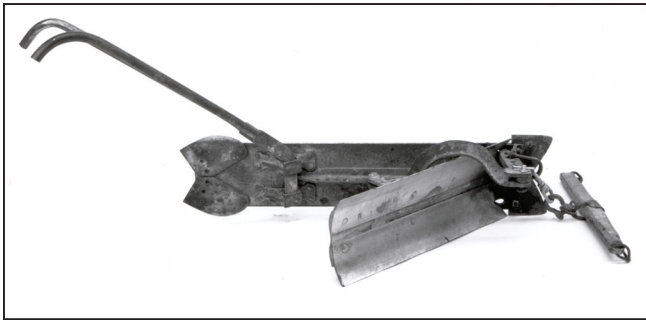

Figure 19—Beatty trail grader.

to manufacture new graders as well as replacement parts. The Beatty grader was designed to function both as a finishing tool following a hillside plow, and as a trail tread maintenance tool. This implement is heavy. The grader, complete with single tree and handles, weighs 250 lb (113 kg). The grader is designed to operate on an off center pull to create a landside or hillside draft (Figure 20).

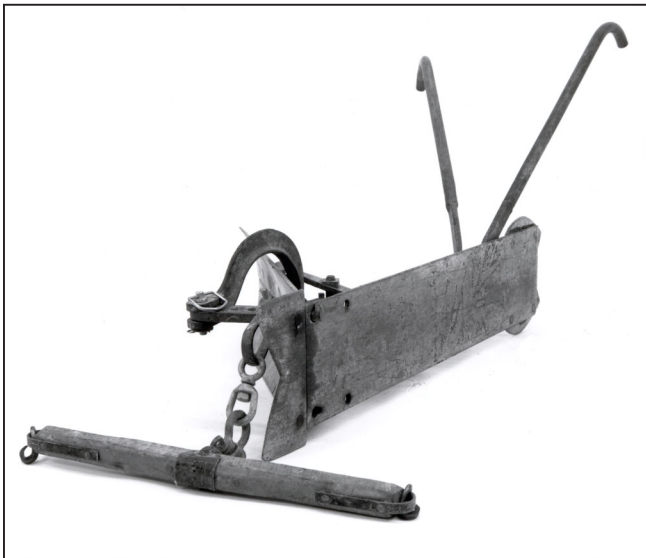

Figure 20—Beatty trail grader. Front view shows single tree, swivel clevis, hitchbar, and handles.

Draft is adjustable from approximately 4 in (100 mm) off center to approximately 12 in (300 mm) off center (Figure 21). The wing can be adjusted to grade a tread of 11 to 26 in (280 to 660 mm) wide (Figure 22). All parts are mounted with either pins or bolts to allow easy dismantling for packing. In its original design, several points were available as accessories to allow easier operation in heavy rubble and beargrass.



Figure 21—Closeup of Beatty trail grader hitchbar and wing.

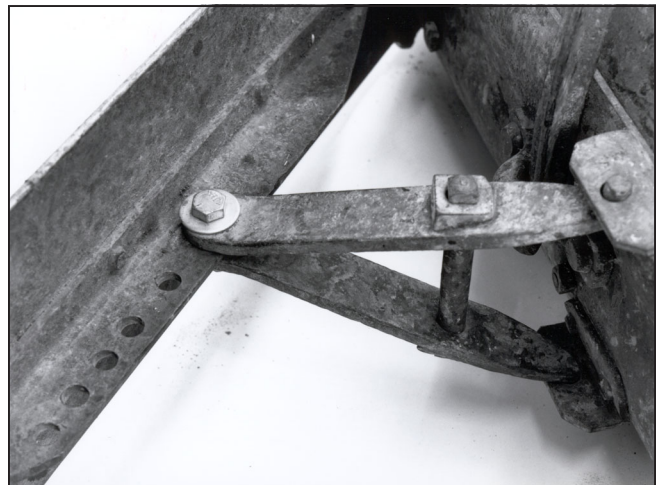

Figure 22—Beatty trail grader wing adjustment.

Fremont Grader

The Fremont grader is an implement designed by Forest Service personnel on the Fremont National Forest, Lakeview Ranger District, in Oregon for finish tread work and light maintenance (Figures 23, 24). The tool is based on a

double ski platform with a blade mounted on a removable turntable that is adjustable for cutting depth. The implement will grade a tread of approximately 28 in (710 mm). The grader cannot be disassembled for packing. The only removable parts are the blade, turntable, handles, and hitch chain. The weight is approximately 200 lb (91 kg).

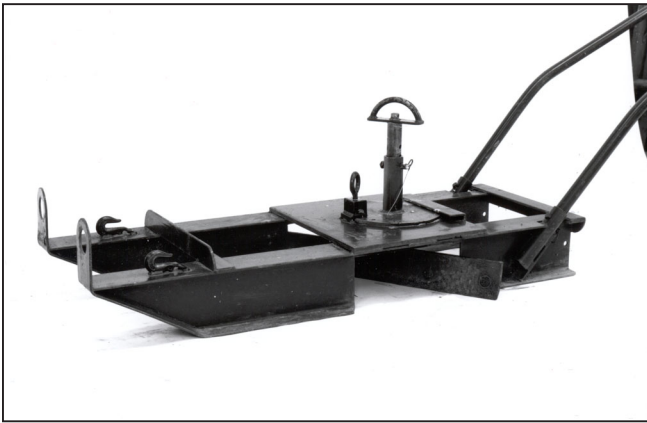

Figure 23—Fremont trail grader.

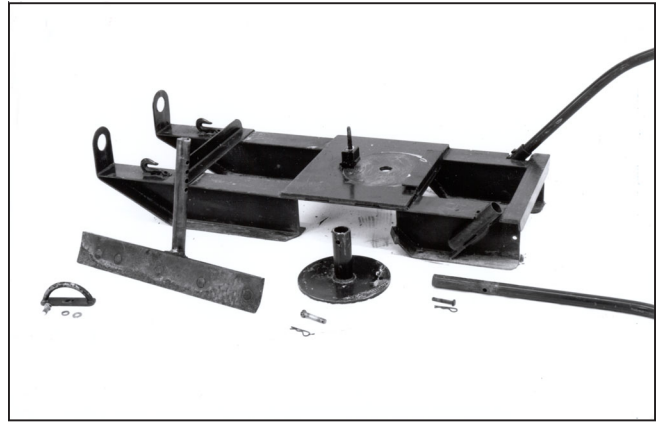

Figure 24—Fremont trail grader parts.

Specialty Equipment Designs

Some specialty equipment is commercially available or can be fabricated from MTDC drawings.

MTDC Combination Plow and Grader

The MTDC combination plow and grader is an implement designed to combine elements of the hillside plow and Beatty grader (Figure 25). The implement design also

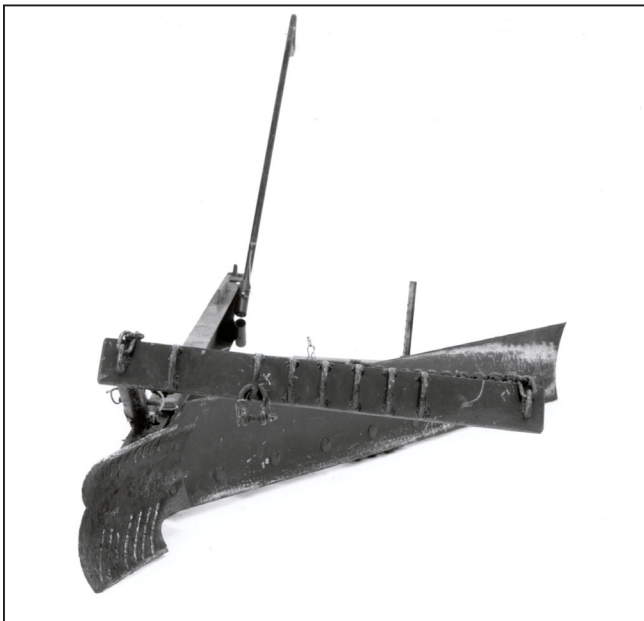

Figure 25—MTDC combination plow and grader.

increases the grading width capability up to 4-ft (1200-mm) trail tread. The MTDC grader is built around a 60-in (1500-mm) main beam (hillside beam) that has a cutting point mounted just in front of the wing. In addition, the beam has a small keel and rock tooth mounted on the rear. The wing is 50 in (1300 mm) long. This grading width is adjustable from approximately 12 to 43 in (300 to 1100 mm) and can be adjusted vertically through a 6-in (150-mm) range with an onboard mounted shoe (Figure 26). Draft is adjustable in two ranges. The vertical draft can be adjusted through a range of 16 in (400 mm). The lateral draft can be adjusted

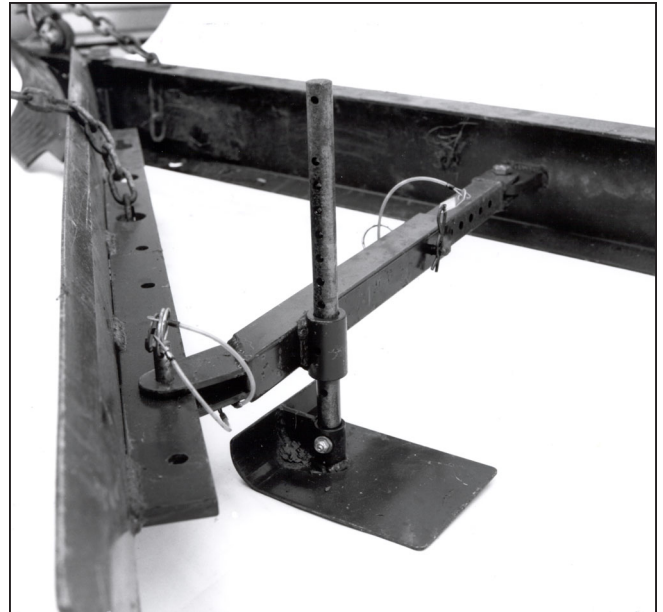

Figure 26—Shoe and wing adjustments of the MTDC combination plow and grader.

through a range of 24 in (600 mm) (Figure 27). The implement is heavy, weighing over 250 lb (113 kg). It disassembles easily for packing; however, it is somewhat awkward to pack because of its length.

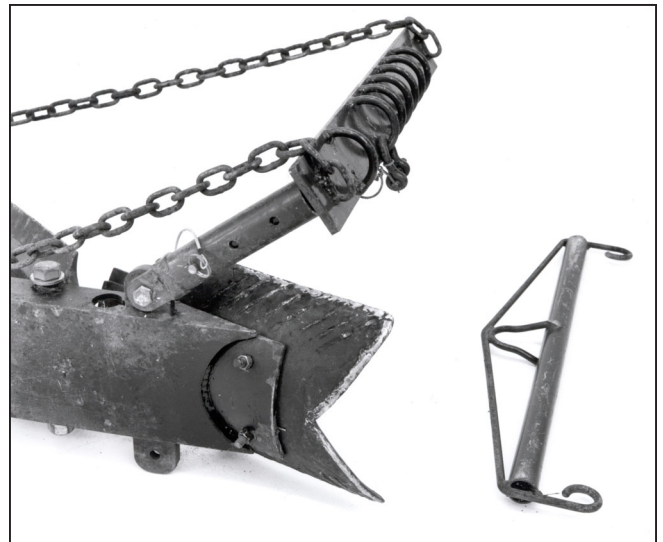

Figure 27—Closeup of the point and hitchbar with single tree of the MTDC combination plow and grader.

Trail Ace and Trail Scoop

Recent developments in stock-drawn trail implements include the Trail Ace and Trail Scoop. These are patented implements designed and built by Clarence McReynolds and Bonner Brumley of White Bird, ID.

The Trail Ace has a rigid boxed steel frame featuring a pivoting hitch frame, rigid steel handles, and 14 sleeves or pockets (Figure 28). The sleeves and pockets are designed to accept the various rock teeth, ripper teeth, and

hardened sod cutter attachments provided with the tool. One or more attachments can be mounted in several orientations. Included in the package is a tool box and a fixed two-way grader blade. The Trail Ace, including all accessories, weighs 146 lb (65 kg).

The Trail Scoop is a small slip constructed of mild steel with hardened rock teeth mounted on the front edge of the scoop (Figure 29). The scoop weighs about 100 lb (39 kg) and has a $1/6$ yd³ (0.13 m³) capacity. It is used for excavating fill materials and transporting them for short distances.



Figure 28—The Trail Ace.



Figure 29—The Trail Scoop.

Performance Testing

All of the implements were tested on the Clearwater National Forest, Lochsa Ranger District portion of the Idaho Centennial Trail No. 2; Fish Butte Trail No. 223; Fish Creek Trail No. 224; and Down River Trail No. 2. (Figure 30).

Soil types were those common to the southern exposure of the Idaho Batholith, or decomposed granitic soils. The projects were done in late May and early June when soil moisture was high (15%). Trail slopes on the Lochsa face typically range to 60% and steeper. Trail grades in the project area ranged from 5 to 30%. Vegetation ranged from bunchgrass with heavy sod; to willow, vine maple, and serviceberry corridors; to the heavy-timbered canopy of cedar, Douglas-fir and white fir on the north sides and bottoms. Only two sections of hard rock were encountered on Trail No. 223. Neither section was more than 30 ft (9 m) long. There were two sections of semihard partially decomposed granite on the upper mile of the trail. The tread on some sections of Trail No. 223 was virtually nonexistent due to years of weathering and elk traveling up and down the slope across the trail. In those sections, tread width averaged less than 10 inches. Trail No. 224, off Fish Creek Canyon, crosses numerous hard rocky spines of essentially unplowable trail interspersed with a long section of plowable decomposed granitic soil. Through the portion of Idaho Centennial Trail No. 2 from the Lochsa Historical Ranger Station to Boulder Flats, the trail grade averaged less than 10%, the soil was granitic, and the vegetation was mostly grass with low ferns and bunch grass.

The project was a Level III maintenance job on a trail that had seen little maintenance in 20 years. Brushing had been completed the previous year and the trail had been logged out before the tread maintenance began.

The crew consisted of the district packer, district trail foreman, and two trail crew members. Experience levels of the packer and crew members with draft stock and stock-drawn trail implements ranged from 1 to 8 years. Fred and Kate, the two Forest Service mules used in the project, had 13 and 14 years experience in harness, respectively. In general, the draft stock used for trail work on this project have more experience than any members of the crew. While using the trail equipment, both the teamster and the equipment handler followed the mules.

The manufacturers of the Trail Ace and Trail Scoop used a two-person crew and their own mule, Stumpy, to demonstrate their trail equipment. One person walked ahead of the mule to lead it. The other person followed the mule to handle the equipment.



Figure 30—The Beatty grader being field tested.

The MTDC grader was used on portions of the Idaho Centennial Trail No. 2 and Down River Trail No. 2. The Chattanooga plow, Fremont grader, and Beatty grader were used on the Fish Butte Trail No. 223. The Trail Ace and Trail Scoop were used on Fish Creek Trail No. 224.

About 1-3/4 mi (2.8 km) of Idaho Centennial Trail No. 2 from the Lochsa Historical Station to Boulder Flats was plowed and graded with the MTDC grader. The first pass was made with the wing shoe lowered to elevate the outside of the wing 4 to 5 in (100 to 125 mm). The return pass was made with the shoe adjusted to allow the grader wing to contact the tread. The spread of the wing was adjusted to obtain a trail tread width of 2 ft (1200 mm). The two passes were completed in 3 hours. The production rate for reconstructing this portion of trail is about 0.4 mph (0.7 km/h).

The MTDC combination plow/grader was also used on Down River Trail No. 2. Two members of the Lochsa trail crew and one mule used the implement to construct tread on 1460 ft (445 m) of trail beginning at the trailhead. On the first pass up the trail, the cutting point was used to cut the inside edge of the trail. On the second pass, the cutting point and the grader blade were used.

Two adjustments were made on the second pass. The offset of the hitch was increased to allow the point to dig more aggressively into the hillside. The spread of the wing was decreased to decrease the finished tread width. The tread was finished on the second pass. The tread maintenance took about 50 minutes, including 10 minutes of

downtime to adjust the wing. The production rate for reconstructing this portion of trail was about 0.6 mph (0.9 km/h).

This implement performed acceptably in terms of building trail. However, design features made this implement more difficult to use than the hillside plow. The single handle provided less control, requiring the operator to 'handle' instead of 'guide' the equipment. Improvements to the cutting point would provide a less aggressive cut.

The Chattanooga hillside plow, the Beatty grader, and the Fremont grader were tested on Fish Butte Trail No. 223. The testing began at the intersection of Trail No. 223 and Fish Butte Road (FS No. 483) 5.2 mi (8.3 km) from the trailhead. Two crew members and one mule made the first pass of the trail with the Chattanooga plow. The other two crew members and a second mule followed with the Fremont grader.

The hillside plow/Fremont grader combination had mixed results. The hillside plow worked satisfactorily. The Fremont grader did an acceptable job of grading but left large clumps of vegetation in the trail. These clumps of vegetation built up between the grader blade and the heel of the front skids on the Fremont grader. The lack of clearance would not allow the vegetation to roll off the grader blade. After about 650 ft (200 m) of trail work, testing of the Fremont grader was discontinued. The crew plowed another 3420 ft (1042 m) for a total of 4070 ft (1241 m). This portion of the trail was completed in 1½ hours. The production

rate for reconstructing this portion of trail was about 0.6 mph (1.0 km/h).

The Chattanooga plow and the Beatty grader was used to finish the remaining 4.4 mi (7 km) of Fish Butte Trail No. 223. A single pass with the plow followed by a single pass with the Beatty grader was completed in 8 hours. The production rate for reconstructing this portion of trail was about 0.6 mph (0.9 km/h).

The developers of the Trail Ace and Trail Scoop, Bonner Brumley and Clarence McReynolds of Whitebird, ID, presented the features of their trail building equipment and demonstrated the implements on Fish Creek Trail No. 224. The two-person crew worked an 1170-ft (357-m) section of trail between 2850 and 4020 ft (869 and 1225 m) from the trailhead.

On the first pass up the trail, a single 2-in (5-cm) ripper tooth was attached to the Trail Ace to dig and loosen the inside edge of the trail. During the second pass going down the trail, the Trail Ace with a three-ripper tooth attachment was used to reestablish the tread width. After returning to the top end on the trail, a third pass was made downhill with the Trail Scoop. During this pass, the tread was finish graded and five water dips were installed. Each pass over the 1170 ft (357 m) of trail took 15 minutes, for a total of 45 minutes. The production rate for reconstructing this portion of trail was about 0.3 mph (0.4 km/h).

Results

The results from the stock-drawn trail equipment testing conducted in early summer 1994 on the Lochsa Ranger District in Idaho are listed in Table 1.

Table 1—Results of 1994 testing.

Trail equipment	Trail	Distance	Time	Passes	People/stock	Production rate
Chattanooga hillside plow	Fish Butte Trail 223	1.2 km	1.5 hr	1	2/1	1.0 km/h
Chattanooga Beatty grader	Fish Butte Trail 223 "	7 km 44 mi	8 hr "	1 each "	2/1 each "	0.9 km/h "
MTDC plow/grader	Down River Trail 2	0.4 km	40 min	2	2/1	0.9 km/h
MTDC plow/grader	Idaho Centennial Trail 2	2.8 km	3 hr	2	2/1	0.7 km/h
Trail Ace	Fish Creek Trail 224	0.4 km	45 min	3	2/1	0.4 km/h
Trail Scoop	"	0.2 mi	"	"	4/2	0.3 mph
Fremont grader	Fish Butte Trail 223	198 m 650 ft	This grader was not suited to the soil and vegetation types at site.			

Discussion of Results

The combination of the hillside plow and the Beatty grader resulted in the highest rate of production under the conditions of this test. The other equipment may not have been as easy to handle as the hillside plow. In addition, the operators have more experience and are more comfortable using the hillside plow and Beatty grader.

The production rate obtained with the MTDC combination plow and grader was about 10% less than that obtained with the hillside plow and Beatty grader combination. This is a relatively small difference. However, the equipment operators agreed that the MTDC grader was much more difficult to control than a hillside plow. Thus, the hillside plow was preferred to the MTDC grader in the test configuration.

The Trail Ace and Trail Scoop combination resulted in the lowest production rate, or about half the production rate of the hillside plow and Beatty grader combination. This result may be misleading for several reasons. First, this test was conducted on a relatively short portion of trail. Second, this portion of the test was conducted by different operators (manufacturers) using a different stock-handling technique. Although this is the lightest of the trail equipment tested, the handle design and angle may be reducing the efficiency of this equipment by requiring more 'handling' than 'guiding' of the implement. This technique requires the crew to make more passes over the trail than the hillside plow and Beatty grader combination, or the MTDC grader.

The Fremont grader did not perform effectively in the soil type and vegetation type in this area of Idaho.

Recommendations

Good equipment, skilled operators, and experienced stock are necessary for a safe and productive trail maintenance crew.

Equipment Modifications

Some changes to the presently available equipment are needed, based on the June 1994 testing.

Fremont Grader

With its present design, the grader has a tendency to clog; it cannot dig into hillside sluff and is difficult to maneuver around sharp inside turns. Since it cannot be broken down, it is not practical to pack. The load weight would exceed 200 lb (90 kg). If the skis were cut just in front of the turntable deck and tabs with hitch pins were added, most of the problems of clogging and poor maneuverability would be solved. The grader's overall length would be increased by 4 in. The additional clearance in front of the blade would give sod, duff, and dirt a better chance to clear the blade. In addition, the pins would allow the grader to be broken into two pieces for packing (Figure 31).

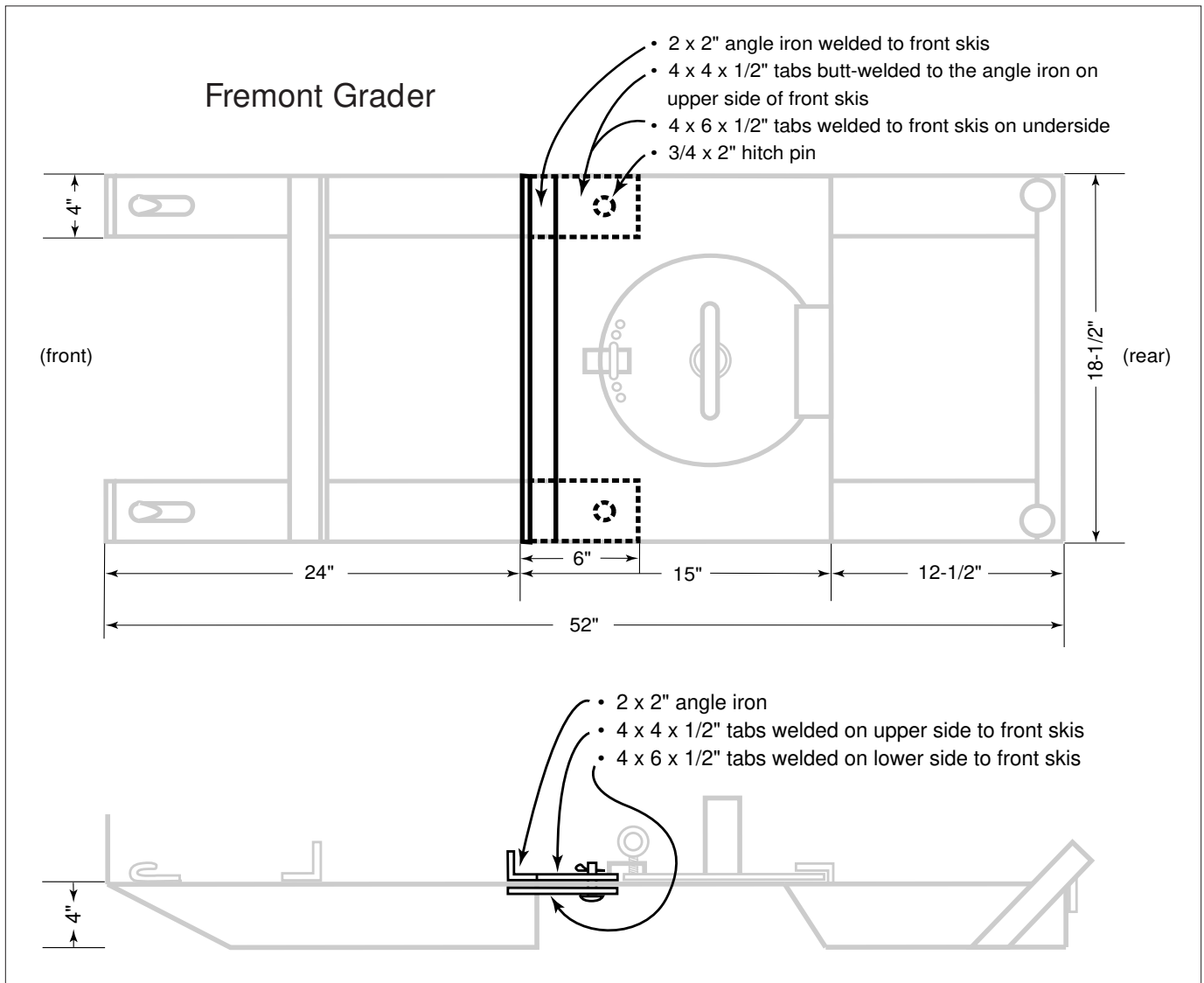

Figure 31—Suggested Fremont grader modification.

Removable hitch pins in front of the blade and deck would allow the implement to articulate, increasing maneuverability. Adding about a 1 $\frac{1}{2}$ -inch blade width at a forward angle would allow material to roll forward, improving clearing. Small rock teeth added to the blade would improve the tool's usefulness on cobbled trails and during dry conditions.

Extending the blade by using detachable rock teeth or Wyoming sod cutters (Figure 32) would allow the tool to cut into the hillside. The addition of angle iron rims in front of and behind the deck would enable users to add rocks

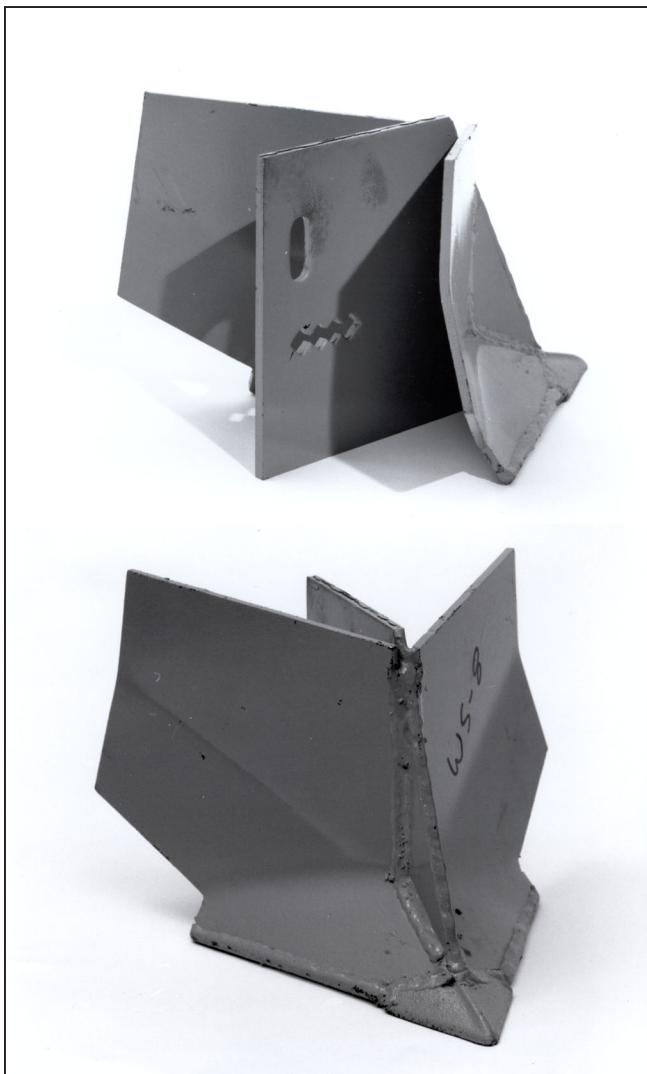

Figure 32—Wyoming sod cutter.

for additional weight, or to transport tools and equipment. That additional capability could be extended even further by adding stake pockets or bunks to transport waterbar materials (Figure 33). Separating the grader by pulling both hitch pins would allow the implement to be packed, with each half weighing approximately 100 lb (45 kg).



Figure 33—Fremont grader being used to haul waterbar materials. The grader blade has been removed.

MTDC Combination Plow and Grader

With its present design, this implement is difficult to control safely. The single handle does not provide adequate leverage to control wing pressure or the depth of the hillside cut. In addition, the handle is easily bent. The use of two handles similar to those of the Beatty grader would solve both problems while increasing safety. The cutting point is fixed and needs to have slotted mounting holes to adjust the aggressiveness of the bite (Figure 34).

The hitch bar places the point of draft too far back for safe operation. The hitch bar needs to be changed so that the point of draft is farther forward and lower, close to a midline on the implement in the first 12 to 18 inches. Replaceable or adjustable keels would also increase the tool's control and effectiveness (Figure 35).

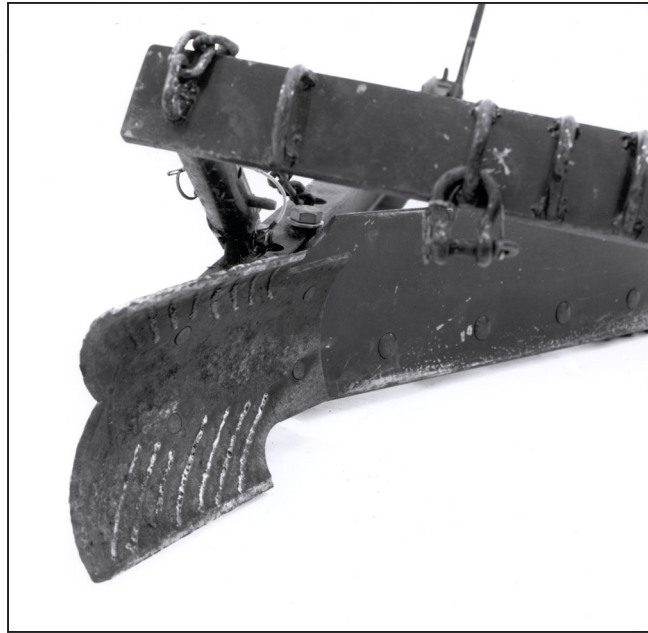

Figure 34—Blade on the MTDC combination plow and grader, fabricated from well casing.

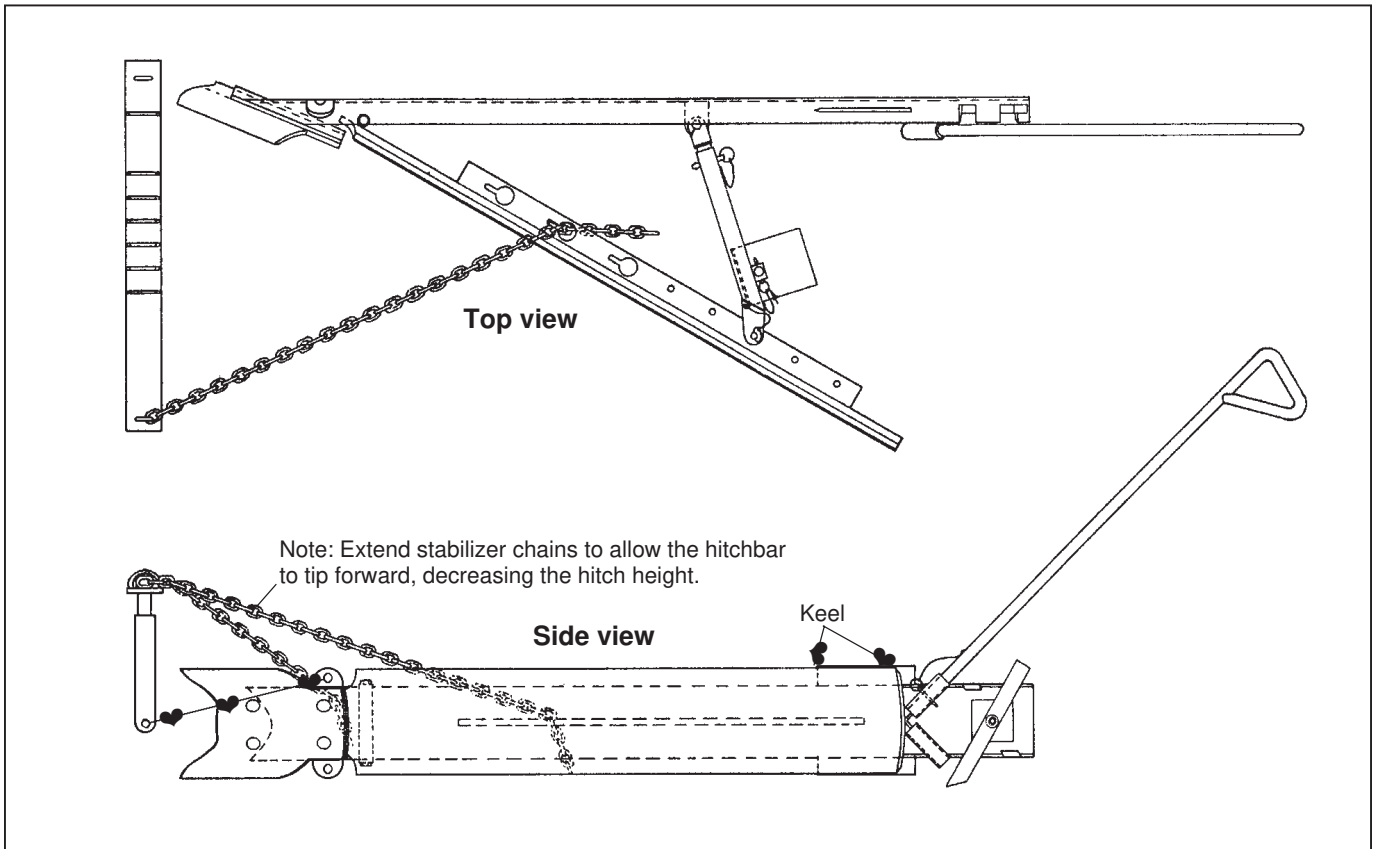

Figure 35—The MTDC combination plow and grader showing modifications.

Trail Ace and Trail Scoop

Overall, these implements are well designed and manufactured. They are relatively lightweight and perform well in rocky soil types and beargrass. However, the handle arrangement and angle of the tool put the operator too close to the implement, forcing the operator to bend over and control the unit with muscles in the small of the back (Figure 36). Longer handles at a more acute angle would



Figure 36—Poor ergonomics of the Trail Ace and Trail Scoop.

increase leverage and move the operator away from sharp cutting points, increasing the equipment's safety and manageability.

Beatty Grader

Additional points need to be available for mounting. Quick-mount capability of rock teeth or hardened cultivator sweeps would increase the implement's effectiveness in a wider range of soil types and seasons.

Vulcan Hillside Plow

Double strapping the gauge wheel with heavier gauge metal would strengthen this weak area.

Adding a jointer knife would increase this plow's effectiveness in heavy sod and heavy root conditions.

A fixed, horizontal 6-position clevis or a swinging clevis needs to be added for hillside draft adjustment before the plow can be used effectively on steep slopes.

Operator Qualifications and Training

Teamster skills are the most important skills and the hardest to acquire. Close communication with the draft stock is the key to preventing accidents. Communication with draft stock on a trail project is accomplished with line contact (through hands and body) and voice. It is difficult to learn these skills without instruction.

Formal instruction is available through courses and clinics. The Arthur Carhart Wilderness Training Center at the Ninemile Ranger District near Huson, MT, provides this training. The Ninemile *Trail Plows and Graders Course* is conducted each spring and is the only clinic addressing trail implements. The 1-week program provides basic hands-on instruction in handling draft stock and using implements for trail construction and rehabilitation.

Draft horse and teamster clinics are held in various parts of the United States and Canada. The most comprehensive information on clinic dates can usually be found in *Small Farm Journal* and *Draft Horse Journal*. Prospective students need to be sure that the clinics emphasize teamster skills and agricultural implements rather than skills needed for vehicles such as hitch wagons.

The skills required to operate the plows and graders are not nearly so esoteric. There is a degree of risk involved with working with stock and stock-drawn implements on steep ground. Initial training and on-the-job training can mitigate that risk.

Lynn Miller has written two books that may help people working with stock-drawn trail equipment: *Training Workhorses, Training Teamsters* (1994, Small Farmer's Journal, Inc., P.O. Box 1627, Sisters, OR 97759) and *Work Horse Handbook* (1981, Lynn R. Miller, HC-81, Box 68, Reedsport, OR 97467). Another book that may be helpful is *The Draft Horse Primer* by Maurice Telleen (1977, Rodale Press, Emmaus, PA).

To address safety issues and to maintain communication with the draft animal, two workers are required for each implement. One person is responsible for handling the animal through the lines. One person runs the implement. This method has an added benefit of placing both the teamster and operator behind the implement. Should anything happen to startle or scare the animal, no one is in a position to be run over or to be trapped between the animal and the implement.

The use of draft stock and trail plows and graders is a cost-effective alternative to traditional hand crews. However, safety and expertise levels should be resolved before using draft stock for trail construction, maintenance, and reconstruction. The use of draft stock is not limited to trails. By using harrows, stone boats, and other implements large amounts of hand work can be eliminated on projects such as trail rehabilitation, campsite rehabilitation, and bridge reconstruction. Draft stock can be used to advantage in virtually any area where more horsepower and less handwork is desired, particularly in remote areas.

Sources

Vulcan Hillside Plow Erb Plow Works
Route 2, Box 14 CR 340
Sugarcreek, OH 44681
(No phone)

Trail Ace and Trail Scoop Clarence McReynolds
1 mile south of Whitebird
Whitebird, ID 83554
Phone: (208) 839-2265

Current price is around \$400. Allow up to 6 months for delivery.

Two-Way Plow Shares Dyko, Incorporated
8021 West Highway 2
Spokane, WA 99204
Contact: Chuck Clark
Phone: (509) 747-4139

MTDC Combination Plow & Grader Drawings USDA-FS, MTDC
5785 Hwy 10 West
Missoula, MT 59808-9361
Phone: (406) 329-3900

Fabrication drawings are available upon request. Specify Drawing No. MEDC-529: Grader-Plow, Mule Drawn.

Replacement two-way plow shares for the Chattanooga hillside plow. The part is identified as FS 120. The price (August 1995) is \$24.69 each, plus shipping from Spokane, WA. The company is not set up to accept credit cards.

Fremont Grader Drawings No fabrication drawings are available for the Fremont grader. The Center may make these drawings available in the future.

Beatty Grader Idaho Falls Foundry and Machine
P.O. Box 2287
501 Northgate Mile
Idaho Falls, ID 83403
Phone: (208) 522-7412

Current source of Beatty grader and replacement parts, cutting points, runners and blades cast from M1 steel.

Library Card

Didier, Steve; Herzberg, Diane. 1996. Stock-drawn equipment for trail work. Tech Rep. 9623-2802-MTDC. Missoula, MT: U.S. Department of Agriculture, Forest Service, Missoula Technology and Development Center. 22 p.

Includes photos of stock-drawn plows and grading equipment that can be used to build and maintain trails in the backcountry. Describes the advantages and disadvantages of different types of equipment. Includes sources where the equipment can be purchased.

Keywords: forest trails; horses; maintenance; mules

For further technical information, contact Steve Didier at:

USDA Forest Service, Lochsa Ranger District
Route 1, Box 398
Orofino, ID 83539
Phone: (208) 926-4274
Fax: (208) 926-7259
Internet: sdidier@fs.fed.us
Lotus Notes: Steve Didier/R1/USDAFS

Additional single copies of this document may be ordered from:

USDA FS, Missoula Technology & Development Center
5785 Hwy 10 West
Missoula, MT 59808-9361
Phone: (406) 329-3978
Fax: (406) 329-3719
Internet: wo_mtdc_pubs@fs.fed.us

An electronic copy of this document is available on the Forest Service's FSWeb intranet at:

<http://fsweb.mtdc.wo.fs.fed.us>