



Chicago Metallic®

Fast. Easy. Customer Focused.®

General APPLICATIONS

200 Snap-Grid™ (Hook) 15/16"

250 Fire-Front Snap-Grid™ (Hook) 15/16"

Seismic 1200 & 1200 (Stab) 15/16"

1250 Fire-Front (Stab) 15/16"

4000 Tempra™ (Stab or Hook) 9/16"

4050 Tempra™ (Stab) 9/16" Fire-Rated

4500 Ultraline™ (Stab) 9/16" Bolt Slot

4550 Ultraline™ (Stab) 9/16" Bolt Slot Fire Rated

4600 Ultraline™ (Stab) 9/16" Bolt Slot 1/8" Reveal

G GRID



15/16" Exposed 
03





9/16" Exposed 
15



9/16" Bolt Slot 
25

Contents

Exposed Tee Systems

- 03..... 200 Snap-Grid™ (Hook) 15/16"
 250 Fire-Front Snap-Grid™ (Hook) 15/16"
- 09..... Seismic 1200 (Stab) 15/16"
1200 (Stab) 15/16"
 1250 Fire-Front (Stab) 15/16"
- 15..... 4000 Tempra™ (Stab / Hook) 9/16"
 4050 Tempra™ 9/16" (Stab) Fire-Rated
- 21..... Accessories
- 22..... Specifications
 - 22 200 Snap-Grid / 250 Fire-Front Snap-Grid
 - 23 Seismic 1200 & 1200 / 1250 Seismic Fire Rated
 - 24 4000 Tempra / 4050 Tempra Fire Rated

Bolt Slot / Reveal Systems

- 25..... 4500 Ultraline™ (Stab) 9/16" Bolt Slot
 4550 Ultraline™ (Stab) 9/16" Bolt Slot
Fire Rated
- 4600 Ultraline™ (Stab) 9/16" Bolt Slot
1/8" Reveal
- 31..... Accessories - Ultraline™ Bolt Slot
- 35..... Specifications
 - 35 4500 Ultraline / 4550 Ultraline Fire Rated
 - 36 4600 Ultraline
- 37..... Product Cross Reference Guide
- 38..... Service Notes
- 39..... General Conditions of Sale

Product Updates



Up-to-date product information for **General Applications** products is available at chicagometallic.com in the Literature Section of each applicable system.

Other Chicago Metallic Suspension Systems

Refer to the **Special Applications** product guide for suspension systems for harsh and controlled environments as well as HRCmax™ systems with 81% recycled content for LEED/ GREEN buildings.

Refer to the **Drywall Applications** product guide for suspension systems for flat and curved drywall as well as Span**Fast**® time saving system for corridors and smaller spaces.



200 Snap-Grid™ 15/16" 250 Fire-Front Snap-Grid™ 15/16"

Non-Fire Rated / Fire Rated
Double Web
Direct Hung Exposed

Exposed 200 Snap-Grid and 250 Fire-Front Snap-Grid tee systems are designed for use with lay-in acoustical panels. These systems, with a 15/16" face, are extremely versatile and offer a wide range of creative ceiling options.

Applications

Can be used with standard lay-in panels, revealed edge, concealed and routed geometric panels. Economical, but quality systems.

Features / Benefits

- **Designed for a wide variety of lay-in panels** / Provides full ceiling accessibility.
- **Available in a wide range of painted and reflective colors** / Many design possibilities as panel can be matched or contrasted. Complete interior concept.
- **Versatility in modular configurations** / Offers additional design possibilities.
- **Sustainability** / Minimum 25% recycled content, 100% locally recyclable.
- **Flame Spread Rating** / Chicago Metallic suspension systems meet a Class-A flame spread rating.

Installation Features / Benefits

- **Hook cross tees** / Allow instant access to plenums overhead.
- **Butt cut cross tees** / Butt cut cross tees allow ceiling panels to lay flat in suspension system, providing a better appearance.
- **Available in a fire rated system** / Expansion reliefs are built into each main tee to compensate for elongation of the materials during fire.
- **Double web construction** / Increased strength for greater versatility and durability.
- **Accommodates standard NEMA Type-G lights and air diffusers** / Allows for integration of lighting and air supply without creating additional labor.

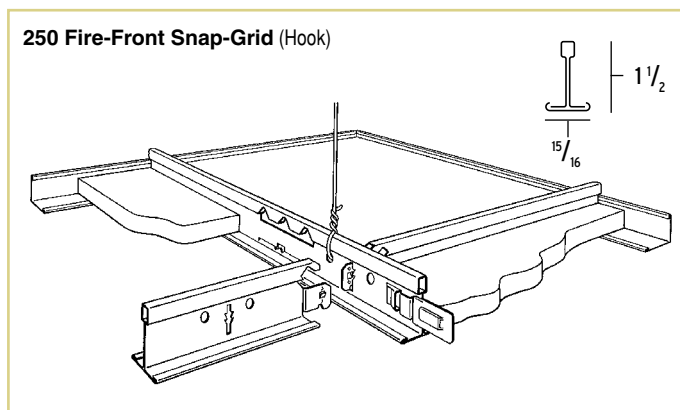
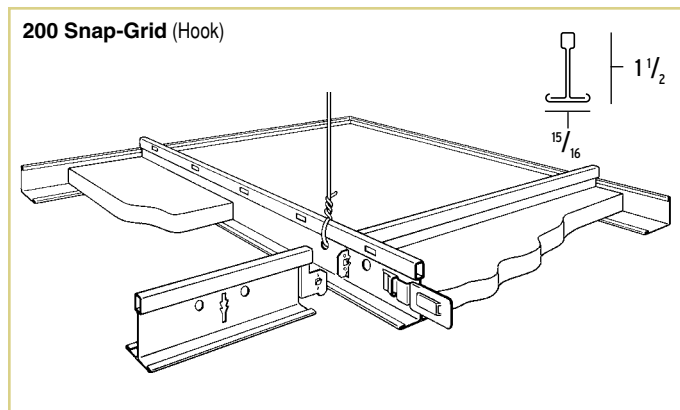

IMPORTANT! A Metallurgist should be consulted regarding the suitability of this product for the environmental conditions in which it is being installed.

Component Slotting and Hanger Hole Placement

All overall lengths shown are nominal dimensions.

Hanger Holes: MAIN TEES – 3/4" each side of cross tee slot, and 2 additional holes equally spaced between cross tee slots.

CROSS TEES – 3/4" each side of cross tee slot, and 2 additional holes equally spaced between cross tee slots, in all cross tees having slots.

200 Snap-Grid™ 15/16"

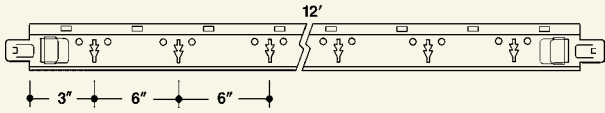

200 & 211 Main Tees: 24 cross tee slots 6" O.C.

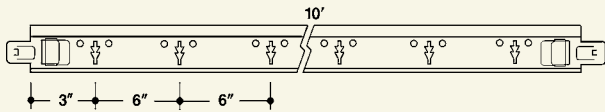

216 Main Tee: 20 cross tee slots 6" O. C.

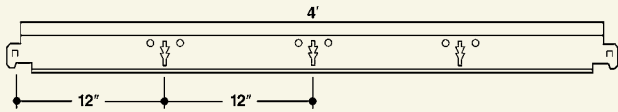

209 Cross Tee: 3 cross tee slots 12" O. C.

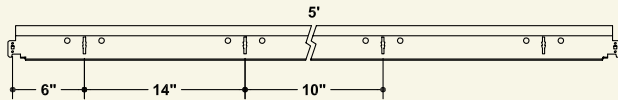

207 Cross Tee: 5 cross tee slots, 1 at midpoint, one 10" each side of midpoint and one 6" from each end.

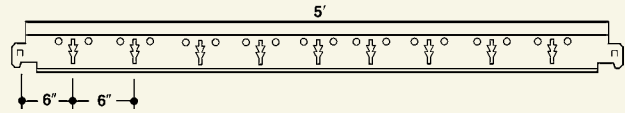

207 Cross Tee: 9 cross tee slots 6" O. C.

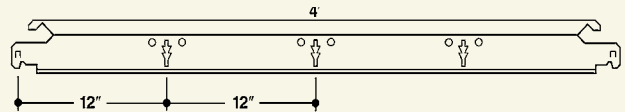

278 Cross Tee: 8 cross tee slots, 12" O.C.

229, 251, 257 & 258 Cross Tees: No cross tee slots.
816 & 817 Variable Placement Cross Tees: No cross tee slots.
288 Grid Adapter: No cross tee slots.

250 Fire-Front Snap-Grid™ 15/16"

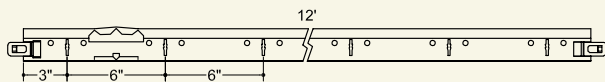

250 & 270 Main Tees: 24 cross tee slots 6" O.C.

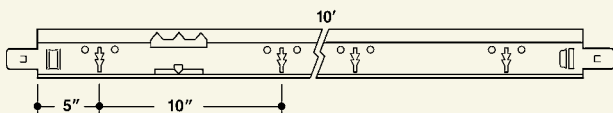

299 Main Tee: 12 cross tee slots 10" O.C.

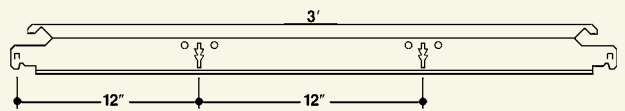

253 Cross Tee: 2 cross tee slots 12" O.C.

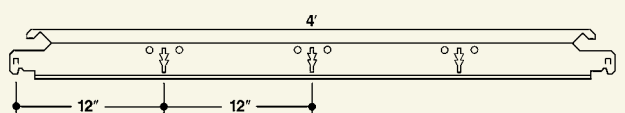

254 Cross Tee: 3 cross tee slots 12" O. C.

251, 252, 257 & 258 Cross Tees: No cross tee slots.

Components 200 Snap-Grid™ 15/16"

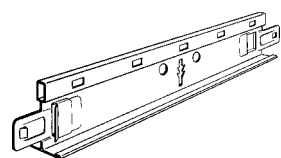

200-211

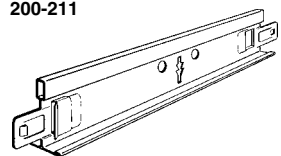

216-299

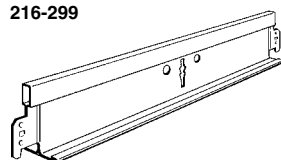

229 - No slots
207-209-278

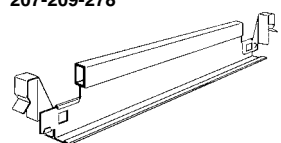

816-817

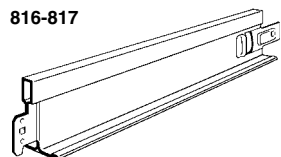

288

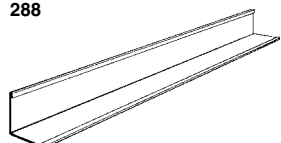

1420-1430-21420-
1425-1428

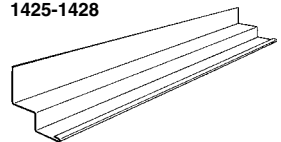

1460-1461-1469

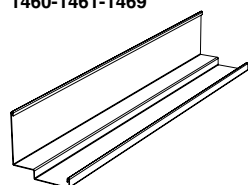

1466

Product Number	Dimensions			ASTM Duty	Per Carton			Service Level
	Length	Height	Face		Feet	Pieces	Weight	
Main Tees								
211.01H	12'	1 1/2"	15/16"	ID	300	25	77	0
200.01H	12'	1 1/2"	15/16"	HD	300	25	89	0
216.01H	10'	1 1/2"	15/16"	ID	250	25	62	1
299.01H*	10'	1 1/2"	15/16"	ID	250	25	65	1
*Used in 20" and 30" modules.								
Cross Tees - Hook - Butt Cut								
229.01H	2'	1 1/2"	15/16"	-	150	75	26	0
209.01H	4'	1 1/2"	15/16"	-	200	50	35	0
207.01H	5'	1 1/2"	15/16"	-	250	50	73	1
278.01H	8'	1 1/2"	15/16"	-	200	25	49	1
Variable Placement Cross Tees — To support acoustical material only								
816.01H	2'	1 1/8"	15/16"	-	80	40	15	2
817.01H	4'	1 1/8"	15/16"	-	160	40	30	2
Grid Adapter — To change main tee direction 90°								
288.01H	9"	1 1/2"	15/16"	-	-	50	10	1
Wall Angles								
1420.01	12' x 15/16" x 15/16"			-	504	42	69	0
1430.01	12' x 7/8" x 7/8"			-	360	30	49	0
21420.01	12' x 15/16" x 15/16"			-	300	25	41	0
1425.01	12' x 2" x 2"			-	240	20	82	0
1428.01	12' x 1" x 2"			-	240	20	54	0
Wall Moldings								
1460.01	10' x 3/4" x 3/8" x 3/8" x 3/4"			-	400	40	64	0
1461.01	10' x 3/4" x 3/4" x 3/4" x 3/4"			-	400	40	90	1
1466.01	12' x 1 3/4" x 3/4" x 1/4" x 1 1/4"			-	240	20	61	1
1469.01	10' x 9/16" x 3/8" x 3/8" x 15/16"			-	400	40	77	1
Hanger Wire								
96CTL144	12' - straight bundled			-	-	-	50	0

Components 250 Fire Front Snap-Grid™ 15/16"

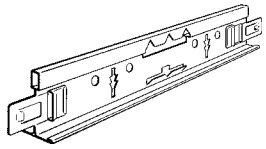

250-270

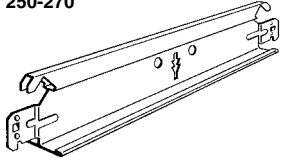

251-252-257-258 – No slots
253-254

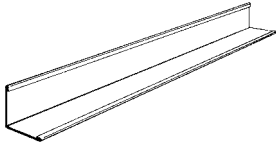

1420-1430-21420-1425-1428

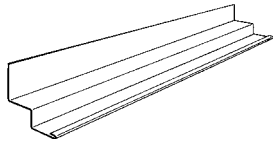

1460-1461-1469

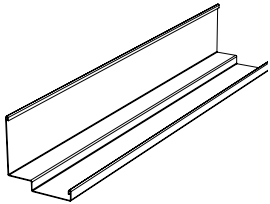

1466

Product Number	Dimensions			ASTM Duty	Per Carton			Service Level
	Length	Height	Face		Feet	Pieces	Weight	
Main Tees								
250.01H	12'	1 1/2"	15/16"	ID	300	25	76	0
270.01H	12'	1 1/2"	15/16"	HD	300	25	91	1
Cross Tees - Hook - Butt Cut								
251.01H	1'	1 1/2"	15/16"	–	100	100	22	1
252.01H	2'	1 1/2"	15/16"	–	150	75	35	0
253.01H	3'	1 1/2"	15/16"	–	150	50	34	1
254.01H	4'	1 1/2"	15/16"	–	200	50	47	0
257.01H	20"	1 1/2"	15/16"	–	125	75	28	1
258.01H	30"	1 1/2"	15/16"	–	125	50	30	1
Wall Angles								
1420.01	12' x 15/16" x 15/16"			–	504	42	69	0
1430.01	12' x 7/8" x 7/8"			–	360	30	49	0
21420.01	12' x 15/16" x 15/16"			–	300	25	41	0
1425.01	12' x 2" x 2"			–	240	20	82	0
1428.01	12' x 1" x 2"			–	240	20	54	0
Wall Moldings								
1460.01	10' x 3/4" x 3/8" x 3/8" x 3/4"			–	400	40	64	0
1461.01	10' x 3/4" x 3/4" x 3/4" x 3/4"			–	400	40	90	1
1466.01	12' x 1 3/4" x 3/4" x 1/4" x 1 1/4"			–	240	20	61	1
1469.01	10' x 9/16" x 3/8" x 3/8" x 15/16"			–	400	40	77	1
Hanger Wire								
96CTL144	12' - straight bundled			–	–	–	50	0

Component Performance Data

Component Load Test Data (based on 1/360 span deflection)

200 Snap-Grid

ALLOWABLE LOAD per ASTM C 635 [■]

Main Tee	Length	Hanger Spacing								
		4'	5'	6'						
216	10'	ID						6.0	4.0	
299	10'	ID						6.0	4.0	
211	12'	ID						6.0	4.0	
200	12'	HD						8.9	5.6	
Cross Tee	Length	1'	20"	2'	30"	3'	4'	5'	6'	8'
229	2'			32.5 [▲]						
209	4'						9.1			
207	5'						8.5			
278	8'								1.8	

[■] To convert data into lb/ft², divide on center spacing of component into lb/ft.

[▲] Limited by safety factor of 2.

* Hanger wire required at midpoint of tee.

250 Fire-Front Snap-Grid

ALLOWABLE LOAD per ASTM C 635 [■]

Main Tee	Length	Hanger Spacing								
		4'	5'	6'						
250	12'	ID						6.0	4.0	
270	12'	HD						8.9	5.6	
Cross Tee	Length	1'	20"	2'	30"	3'	4'	5'	6'	8'
252	2'			41.0 [▲]						
251*	12"									
257*	20"			90.0 [▲]						
258*	30"				57.4					
253	3'						34.7			
254	4'						14.1			

[■] To convert data into lb/ft², divide on center spacing of component into lb/ft.

[▲] Limited by safety factor of 2.

Non-Fire Rated Assemblies

Hanger Positions for Non-Fire Rated Situations
This illustrates hanger positions for single fixtures in a field.

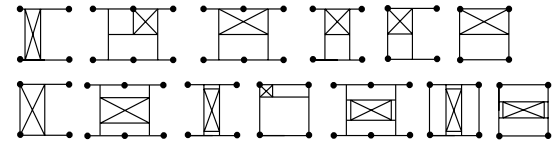

Provide extra hangers for tandem fixtures.

UL® Fire Rated Assemblies

floor-ceiling type 250

A202, A210, A211, A212, D203, D205, D209, D215, D216, D218, G007, G008, G022, G036, G201, G202, G204, G208, G209, G210, G211, G213, G214, G215, G216, G217, G218, G222, G227, G228, G229, G231, G234, G236, G241, G242, G243, G244, G248, G250, G255, G256, G258, G259, J201, L005, L006, L201, L202, L206, L208, L209, L210, L211, L212

roof-ceiling type 250

P201, P202, P203, P204, P206, P207, P210, P211, P213, P214, P215, P216, P217, P219, P225, P227, P228, P229, P230, P231, P235, P237, P238, P239, P241, P242, P244, P245, P246, P250, P251, P253, P255, P257, P259, P260, P261, P262, P264

Hanger Positions for Fire Rated Situations

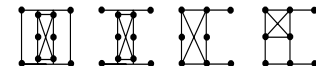

Fixture weight based on single fixtures only and are covered in the table. Refer to specific design numbers for allowable number of fixtures per square footage of ceiling area.

Light Fixture Load Test Data (based on 1/360 span deflection)

LIGHT FIXTURES MAIN & CROSS TEES - ALLOWABLE FIXTURE WT. - LBS.

Dimensions	200 Snap-Grid			250 Fire-Front Snap-Grid	
	200	211	299	250	270
	207	209	207	254	254
1' x 4'	32.4	56.4		55.6	67.6
2' x 2'	29.2	34.8		49.6	52.8
2' x 4'	40.8	47.2		64.0 [▲]	76.0 [▲]
2' x 5'	40.8				
3' x 3'	63.0 [▲]				
20" x 48"			37.6		
20" x 60"			37.6		

[▲] Limited by safety factor of 2.

Specification Data

suspension type		200	250
		Snap-Grid	Fire-Front Snap-Grid
material	body	HD Galvanized	•
	cap	galvanized	galvanized
size	width	15/16"	15/16"
	height	1 1/2"	1 1/2"
fire	fire rated ¹		•
performance	heavy duty per ASTM C 635	•	•
	intermediate duty per ASTM C 635	•	•
	demountable	•	•
seismic	zones / categories	1, 2 / A, B, C	1, 2 / A, B, C
warranty	40 year limited	•	•
sustainability	Minimum 25% recycled content, 100% locally recyclable, global/regional manufacture	•	•

Palletization

Product Number	Cartons Per Pallet	Weight Per Pallet	LF Per Pallet	Product Number	Product Length	Cartons Per Pallet	Weight Per Pallet	LF Per Pallet
Main Tees				1 Ft. Cross Tee				
200.01H	28	2,492	8,400	251.01H		50	1,200	5,000
211.01H	28	2,156	8,400	30 In. Cross Tee				
216.01H	28	1,736	7,000	258.01H	Packaged To Order			
250.01H	28	2,156	8,400	20 In. Cross Tee				
270.01H	28	2,604	8,400	257.01H	Packaged To Order			
299.01H	28	1,820	7,000	Wall Angles / Moldings				
8 Ft. Cross Tee				Angles				
278.01H	28	1,372	5,600	1420.01	12	30	2,070	15,120
5 Ft. Cross Tee				1425.01	12	30	2,460	7,200
207.01H	30	2,310	7,500	1428.01	12	30	1,620	7,200
4 Ft. Cross Tees				1430.01	12	40	1,960	14,400
209.01H	40	1,960	8,000	21420.01	12	30	1,230	9,000
254.01H	40	1,880	6,400	Shadow Moldings				
3 Ft. Cross Tee				1460.01	10	32	2,048	12,800
253.01H	Packaged To Order			1461.01	10	32	2,880	12,800
2 Ft. Cross Tees				1466.01	12	20	1,220	4,800
229.01H	50	1,400	7,500	1469.01	10	Packaged To Order		
252.01H	50	1,750	7,500					

Seismic 1200, 1200 and 1250 Fire-Front 15/16"

Non-Fire Rated / Fire Rated
Double Web
Direct Hung Exposed

These systems are designed for use with lay-in acoustical panels. These systems, with a 15/16" face, are extremely versatile and offer a wide range of creative ceiling options.

Applications

Use with standard lay-in panels, revealed edge, concealed and routed geometric panels. Economical yet quality systems which can also be used in seismic installations.

Features / Benefits

- **Designed for a wide variety of lay-in panels** / Provides full ceiling accessibility.
- **Available in a wide range of painted and reflective colors** / Many design possibilities as panel can be matched or contrasted. Total interior concept.
- **Versatility in modular configurations** / Offers additional design possibilities.
- **Sustainability** / Minimum 25% recycled content, 100% locally recyclable.
- **Flame Spread Rating** / Chicago Metallic suspension systems meet a Class-A flame spread rating.

Installation Features / Benefits

- **Stab-in cross tees** / Tees cantilever during installation and will not fall out, making for an easier installation. Protects against lateral pull-out.
- **Cross tees feature a stepped end design** / Stepped end cross tees provide additional support.
- **Cross tees fully integrate with all 200 System main and cross tees** / This compatibility allows for choice of either hook or stab cross tees.
- **Meets seismic requirements** / Stab cross tees protect against lateral pull out. Compliant with worldwide seismic requirements, including IBC.
- **QuickClick® end clips** / Quick, easy tee installation with an audible "click" signalling firm engagement.
- **Available in a fire rated system** / Expansion reliefs are built into each main tee to compensate for elongation of the materials during fire.
- **Double web construction** / Increased strength for greater versatility and durability.
- **Seismic Perimeter Clip (1200 System Only)** / Allows for a visually appealing ceiling with the use of a 15/16" angle in seismic zones D, E and F.
- **Accommodates standard NEMA Type-G lights and air diffusers** / Allows for integration of lighting and air supply without creating additional labor.

IMPORTANT! A Metallurgist should be consulted regarding the suitability of this product for the environmental conditions in which it is being installed.

Seismic 1200 (Stab)

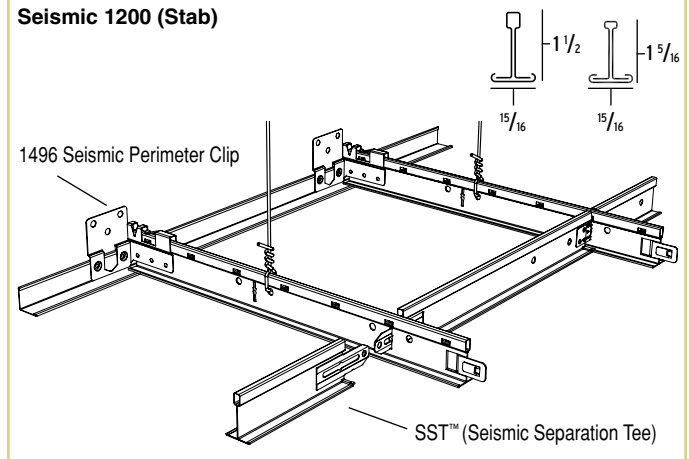

1200 (Stab)

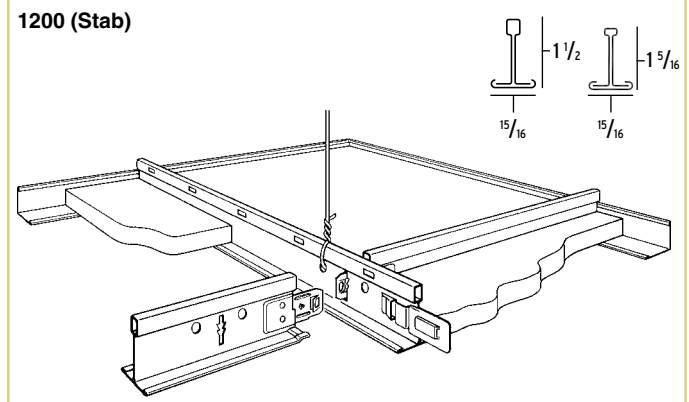

1250 Fire-Front (Stab)

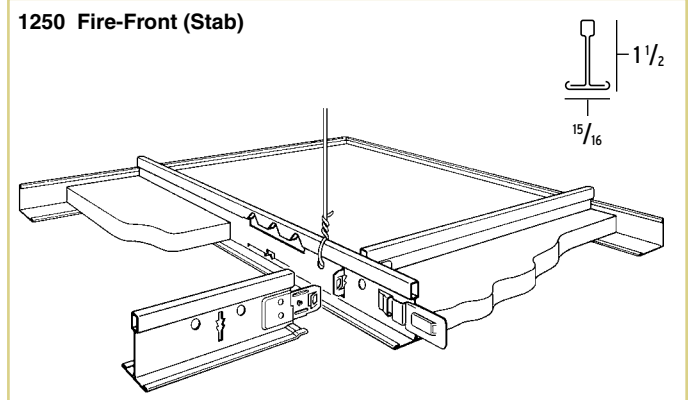

International Building Code (IBC) Seismic Category C, D, E & F Alternative Perimeter Treatment using 1496 Perimeter Clip

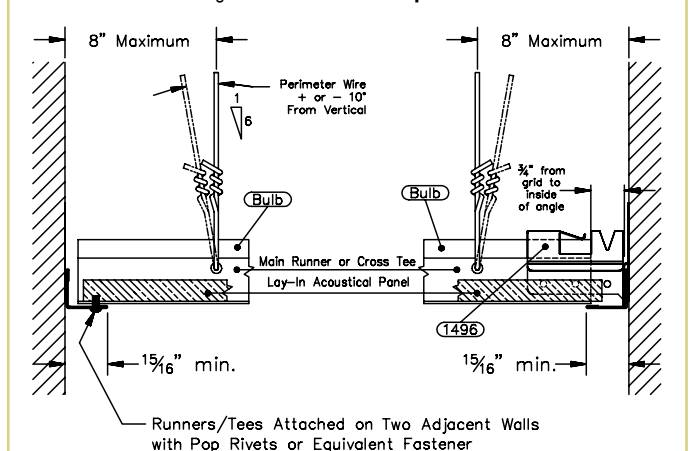

Component Slotting and Hanger Hole Placement

All overall lengths shown are nominal dimensions.

Hanger Holes: MAIN TEES – 3/4" each side of cross tee slot, and 2 additional holes equally spaced between cross tee slots.

CROSS TEES – 3/4" each side of cross tee slot, and 2 additional holes equally spaced between cross tee slots, in all cross tees having slots.

Seismic 1200 & 1200 15/16"

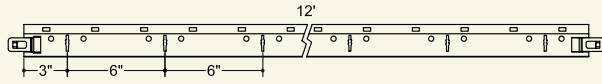

200 & 211 Main Tees: 24 cross tee slots 6" O.C.

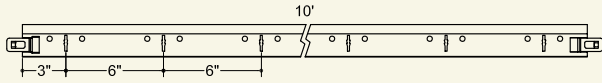

216 Main Tee: 20 cross tee slots 6" O.C.

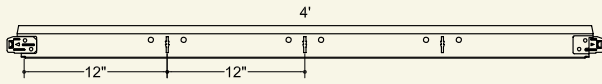

1210, 1214 & 1274 Cross Tees: 3 cross tee slots 12" O.C.

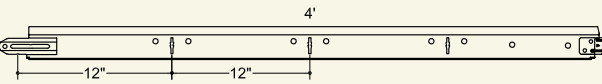

1214SST Cross Tee: 3 cross tee slots 12" O.C.

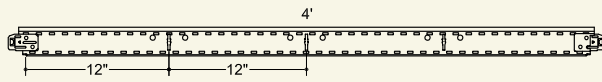

1280 Cross Tee: 3 cross tee slots 12" O.C.

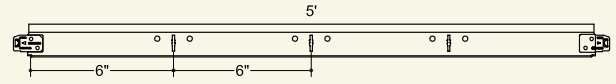

1207 Cross Tee: 3 cross tee slots, 6" O.C.

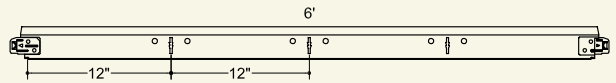

1236 Cross Tee: 3 cross tee slots, 12" O.C.

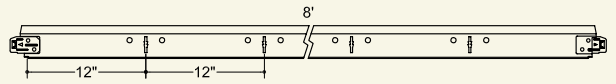

1278 Cross Tee: 8 cross tee slots, 12" O.C.

1202 Cross Tee: No cross tee slots.

816 & 817 Variable Placement Cross Tees: No cross tee slots.

1250 Fire-Front 15/16"

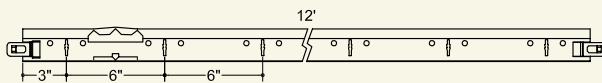

250 & 270 Main Tees: 24 cross tee slots 6" O.C.

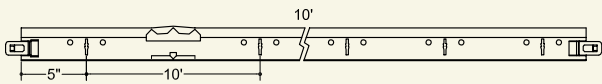

299 Main Tee: 12 cross tee slots 10" O.C.

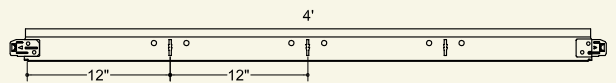

1254 Cross Tee: 3 cross tee slots 12" O.C.

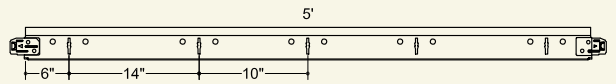

1296 Cross Tee: 5 cross tee slots, 1 at midpoint, 2 spaced 10" each side of midpoint and 2 spaced 24" each side of midpoint.

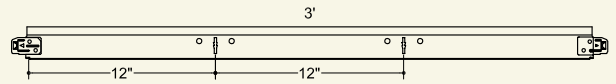

1253 Cross Tee: 3 cross tee slots 12" O.C.

1251, 1252, 1257 & 1258 Cross Tees: No cross tee slots.

Components

Seismic 1200 & 1200 15/16"

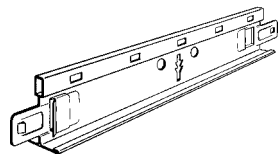

200-211

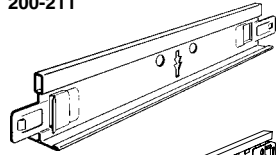

216

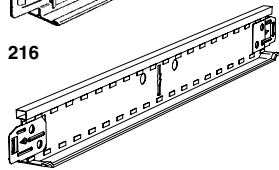

1202 - No slots
1280

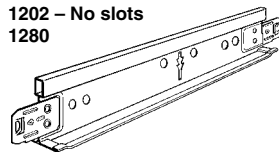

1210-1214-1207-
1236-1274

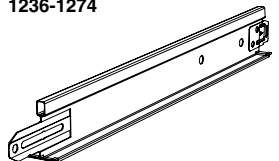

1214SST

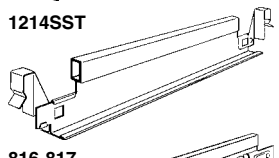

816-817

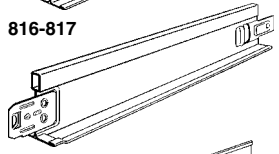

1288



1420-1430-21420-1425-1428

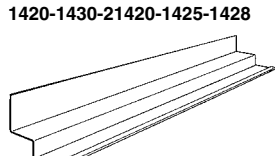

1460-1461-1469

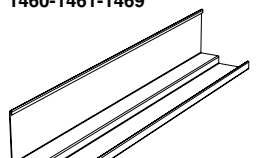

1466

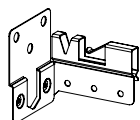

1496



Product Number	Dimensions			ASTM Duty	Per Carton			Service Level
	Length	Height	Face		Feet	Pieces	Weight	
Main Tees								
211.01H	12'	1 1/2"	15/16"	ID	300	25	77	0
200.01H	12'	1 1/2"	15/16"	HD	300	25	89	0
216.01H	10'	1 1/2"	15/16"	ID	250	25	62	1
Cross Tees - Stab - Override								
1202.01H	2'	1 5/16"	15/16"	-	150	75	24	0
1210.01H <i>Quick-Click</i>	4'	1 1/2"	15/16"	-	200	50	34	0
1214.01H <i>Quick-Click</i>	4'	1 1/2"	15/16"	-	200	50	45	0
1214.01SST	4'	1 1/2"	15/16"	-	200	50	46	0
1274.01H*	4'	1 1/2"	15/16"	-	200	50	61	0
1280.01H	4'	1 1/2"	15/16"	-	200	50	33	0
1207.01H	5'	1 1/2"	15/16"	-	250	50	73	1
1236.01H	6'	1 1/2"	15/16"	-	150	25	37	1
1278.01H	8'	1 1/2"	15/16"	-	200	25	46	1
* Used to support NEMA Type G light fixture.								
Variable Placement Cross Tees — To support acoustical material only								
816.01H	2'	1 1/8"	15/16"	-	80	40	21	2
817.01H	4'	1 1/8"	15/16"	-	160	40	40	2
Grid Adapter — To change main tee direction 90°								
1288.01H	9"	1 1/2"	15/16"	-	-	50	10	1
Wall Angles								
1420.01	12' x 15/16" x 15/16"			-	504	42	69	0
1430.01	12' x 7/8" x 7/8"			-	360	30	52	0
21420.01	12' x 15/16" x 15/16"			-	300	25	41	0
1425.01	12' x 2" x 2"			-	240	20	82	0
1428.01	12' x 1" x 2"			-	240	20	54	0
Wall Moldings								
1460.01	10' x 3/4" x 3/8" x 3/8" x 3/4"			-	400	40	64	0
1461.01	10' x 3/4" x 3/4" x 3/4" x 3/4"			-	400	40	90	1
1466.01	12' x 1 3/4" x 3/4" x 1/4" x 1 1/4"			-	240	20	61	1
1469.01	10' x 9/16" x 3/8" x 3/8" x 15/16"			-	400	40	77	1
Seismic Perimeter Clip - For use with 1280 System in Category C, D, E and F installations								
1496.00	-	-	-	-	-	100	10	0
Hanger Wire								
96CTL144	12' - straight bundled			-	-	-	50	0
Push Rivets Fasteners** — For use with SST 4' Cross Tees								
460.08	-	-	-	-	-	65	0.1	0

** Included with SST. Part No. 460.08 is for additional fasteners that may be ordered separately if required.

Components 1250 Fire-Front 15/16"

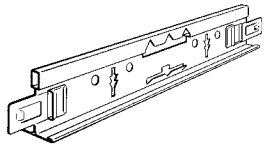

250-270

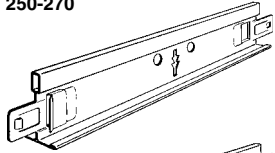

299

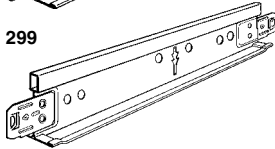

1251-1252-1257-1258 - No slots
1253-1254-1296

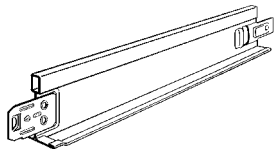

1288

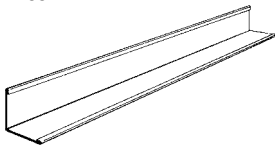

1420-1430-21420-1425-1428

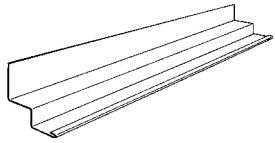

1460-1461-1469

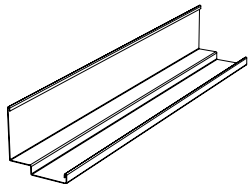

1466

Product Number	Dimensions			ASTM Duty	Per Carton			Service Level
	Length	Height	Face		Feet	Pieces	Weight	
Main Tees								
250.01H	12'	1 1/2"	15/16"	ID	300	25	76	0
270.01H	12'	1 1/2"	15/16"	HD	300	25	91	0
299.01H*	10'	1 1/2"	15/16"	ID	250	25	65	1
*Used in 20" and 30" modules.								
Cross Tees - Stab - Override								
1257.01H	20"	1 1/2"	15/16"	-	125	75	30	1
1258.01H	30"	1 1/2"	15/16"	-	125	50	29	2
1251.01H	1'	1 1/2"	15/16"	-	100	100	23	0
1252.01H	2'	1 1/2"	15/16"	-	150	75	35	0
1253.01H	3'	1 1/2"	15/16"	-	150	50	36	1
1254.01H	4'	1 1/2"	15/16"	-	200	50	44	0
1296.01H	5'	1 1/2"	15/16"	-	250	50	57	1
Grid Adapter — To change main tee direction 90°								
1288.01H	9"	1 1/2"	15/16"	-	-	50	10	1
Wall Angles								
1420.01	12' x 15/16" x 15/16"			-	504	42	69	0
1430.01	12' x 7/8" x 7/8"			-	360	30	52	0
21420.01	12' x 15/16" x 15/16"			-	300	25	41	0
1425.01	12' x 2" x 2"			-	240	20	82	0
1428.01	12' x 1" x 2"			-	240	20	54	0
Wall Moldings								
1460.01	10' x 3/4" x 3/8" x 3/8" x 3/4"			-	400	40	64	0
1461.01	10' x 3/4" x 3/4" x 3/4" x 3/4"			-	400	40	90	1
1466.01	12' x 1 3/4" x 3/4" x 1/4" x 1 1/4"			-	240	20	61	1
1469.01	10' x 9/16" x 3/8" x 3/8" x 15/16"			-	400	40	77	1
Hanger Wire								
96CTL144	12' - straight bundled			-	-	-	50	0

Component Performance Data

Component Load Test Data (based on $1/360$ span deflection)

Seismic 1200 & 1200

ALLOWABLE LOAD per ASTM C 635 [■]

Main Tee	Length	Hanger Spacing						
		4'	5'	6'				
216	10'	ID	6.0	4.0				
211	12'	ID	6.0	4.0				
200	12'	HD	8.9	5.6				
Cross Tee	Length	1'	2'	3'	4'	5'	6'	8'
1202	2'		22.8 [▲]					
1210	4'				9.3			
1214	4'				14.0			
1214SST	4'				14.0			
1274	4'				17.0			
1280	4'				6.9			
1207	5'					8.5		
1236	6'							–
1278	8'							1.8

[■]To convert data into lb/ft², divide on center spacing of component into lb/ft.

[▲]Limited by safety factor of 2.

1250 Fire-Front

ALLOWABLE LOAD per ASTM C 635 [■]

Main Tee	Length	Hanger Spacing						
		4'	5'	6'				
299	10'	ID	6.0	4.0				
250	12'	ID	6.0	4.0				
270	12'	HD	8.9	5.6				
Cross Tee	Length	1'	2'	3'	4'	5'	6'	8'
1251	12"	–						
1252	2'		40.5 [▲]					
1253	3'			29.3				
1254	4'				14.0			
1296	5'					7.0		

[■]To convert data into lb/ft², divide on center spacing of component into lb/ft.

[▲]Limited by safety factor of 2.

Light Fixture Load Test Data (based on $1/360$ span deflection)

LIGHT FIXTURES MAIN & CROSS TEES - ALLOWABLE FIXTURE WT. – LBS.

Dimensions	1200 Seismic		1250 Fire-Front Seismic		
	211	211	250	270	270
	1210		1254	1254	1274
1' x 4'	56.4	56.4	55.6	67.6	70.8
2' x 2'	34.8	34.8	49.6	52.8	60.4
2' x 4'	47.2	47.2	64.0 [▲]	76.0 [▲]	88.8

[▲]Limited by safety factor of 2.

Non-Fire Rated Assemblies

Hanger Positions for Non-Fire Rated Situations
This illustrates hanger positions for single fixtures in a field.

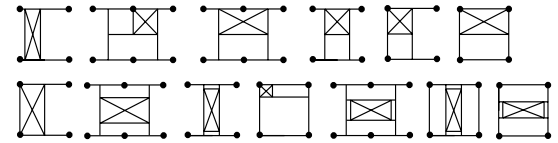

Provide extra hangers for tandem fixtures.

UL[®] Fire Rated Assemblies

floor-ceiling type 1250

A202, A210, A211, A212, D203, D205, D209, D215, D216, D218, G007, G008, G022, G036, G201, G202, G204, G208, G209, G210, G211, G213, G214, G215, G216, G217, G218, G222, G227, G228, G229, G231, G234, G236, G241, G242, G243, G244, G248, G250, G255, G256, G258, G259, J201, L005, L006, L201, L202, L206, L208, L209, L210, L211, L212

roof-ceiling type 1250

P201, P202, P203, P204, P206, P207, P210, P211, P213, P214, P215, P216, P217, P219, P225, P227, P228, P229, P230, P231, P235, P237, P238, P239, P241, P242, P244, P245, P246, P250, P251, P253, P255, P257, P259, P260, P261, P262, P264

Hanger Positions for Fire Rated Situations

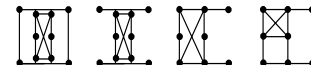

Fixture weight based on single fixtures only and are covered in the table. Refer to specific design numbers for allowable number of fixtures per square footage of ceiling area.

Specification Data

suspension type		Seismic 1200 & 1200	1250 Fire-Front
material	body	HD Galvanized	•
	cap	galvanized	galvanized
size	width	15/16"	15/16"
	height	1 1/2" / 1 5/16"	1 1/2"
fire	fire rated ¹		•
performance	heavy duty per ASTM C 635	•	
	intermediate duty per ASTM C 635		•
	demountable		
seismic	zones / categories	3, 4 / D, E, F	3, 4 / D, E, F
warranty	40 year limited	•	•
sustainability	Minimum 25% recycled content, 100% locally recyclable, global/regional manufacture	•	•

1 - Traditional grid products have a Class A approved, factory painted, baked-on finish.

Palletization

Product Number	Cartons Per Pallet	Weight Per Pallet	LF Per Pallet	Product Number	Cartons Per Pallet	Weight Per Pallet	LF Per Pallet
Main Tees				2 Ft. Cross Tee			
200.01H	28	2,492	8,400	1202.01H	50	1,200	7,500
211.01H	28	2,156	8,400	1252.01H	50	1,750	7,500
216.01H	28	1,736	7,000	1 Ft. Cross Tee			
250.01H	28	2,128	8,400	1251.01H	50	1,150	5,000
270.01H	28	2,548	8,400	Misc Cross Tees			
299.01H	28	1,820	7,000	1257.01H	50	1,500	6,250
8 Ft. Cross Tee				1258.01H	40	1,160	5,000
1278.01H	28	1,288	5,600				
6 Ft. Cross Tee							
1236.01H	28	1,036	4,200				
5 Ft. Cross Tee							
1207.01H	30	2,175	7,500				
1296.01H	30	1,710	7,500				
4 Ft. Cross Tees							
1210.01H	40	1,360	8,000				
1214.01H	40	1,800	8,000				
1214.01SST	40	1,840	8,000				
1274.01H	40	2,440	8,000				
1280.01H	40	1,320	8,000				
1215.01H	40	1,760	8,000				
1254.01H	40	1,760	8,000				
3 Ft. Cross Tee							
1253.01H	Packaged To Order						

Product Number	Length	Cartons Per Pallet	Weight Per Pallet	LF Per Pallet
Wall Angles / Moldings				
Angles				
1420.01	12	30	2,070	15,120
1425.01	12	30	2,460	7,200
1428.01	12	30	1,620	7,200
1430.01	12	40	1,960	14,400
21420.01	12	30	1,230	9,000
Shadow Moldings				
1460.01	10	32	2,048	12,800
1461.01	10	32	2,880	12,800
1466.01	12	20	1,220	4,800
1469.01	10	Packaged To Order		

4000 Tempra™ 9/16"

4050 Tempra™ 9/16" Fire Rated

Non-Fire Rated / Fire Rated
Double Web
Direct Hung Exposed

4000 Tempra and fire rated 4050 Tempra systems are exposed with a narrow face that accentuates a ceiling design with its subtle, crisp, clean lines. These systems minimize the appearance of the ceiling grid, while emphasizing the aesthetic qualities of the ceiling design.

Applications

Can be used as an alternative to standard lay-in systems, revealed systems or concealed systems. Tempra works exceptionally well with the geometric shapes and patterns of routed panels.

Features / Benefits

- **9/16" narrow capped face** / Allows for more of the ceiling panel and less of the ceiling grid to be visible, providing a monolithic look.
- **Designed for standard lay-in and reveal-edge panels** / Provides full ceiling accessibility. Panels are readily available, economical and easy to install.
- **Wide range of possible modular configurations** / Offers additional design possibilities.
- **Available in a wide range of painted and reflective colors** / Many design possibilities as panel can be matched or contrasted. Total interior concept.
- **Sustainability** / Minimum 25% recycled content, 100% locally recyclable.
- **Flame Spread Rating** / Chicago Metallic suspension systems meet a Class-A flame spread rating.

Installation Features / Benefits

- **Panel self-centering mechanisms** / The built-in self-centering device keeps lay-in panels perfectly aligned to hide panel edges.
- **Stab-in cross tees** / Tees cantilever during installation and will not fall out, making for an easier installation. Protects against lateral pull-out.
- **Butt cut cross tees (4000 system only)** / Butt cut cross tees allow ceiling panels to lay flat in suspension system, providing a better appearance.
- **QuickClick® end clips** / Quick, easy tee installation with an audible "click" signalling firm engagement.
- **Standard inverted T, suspended ceiling system** / Installs easily, like standard exposed systems.
- **Double web construction** / Increased strength for better durability.
- **Seismic Perimeter Clip (4000 System Only)** / Allows for a visually appealing ceiling with the use of a 15/16" angle in seismic zones C, D, E and F.
- **Accommodates standard NEMA Type-G lights and air diffusers** / Allows for integration of lighting and air supply without creating additional labor.

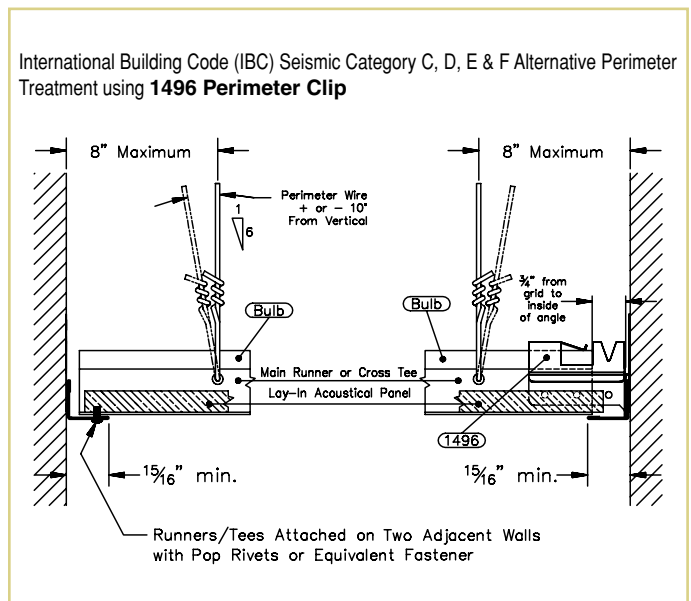
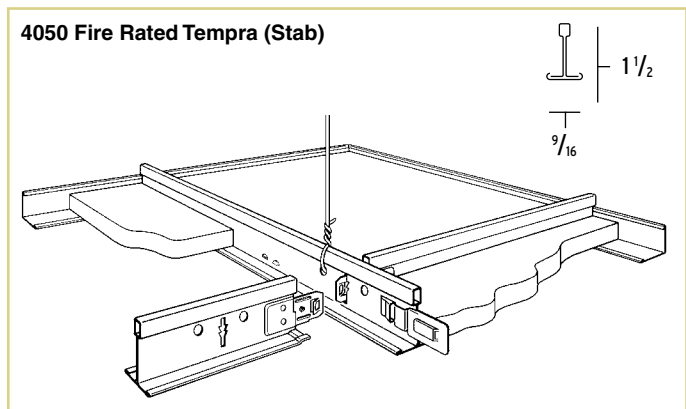
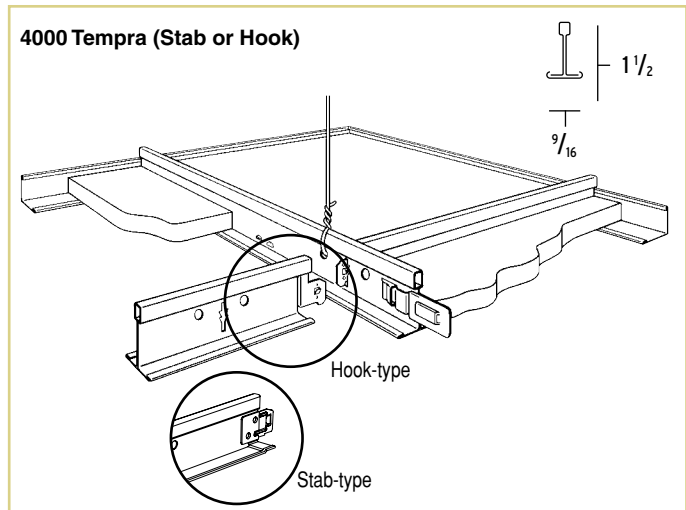

IMPORTANT! A Metallurgist should be consulted regarding the suitability of this product for the environmental conditions in which it is being installed.



Component Slotting and Hanger Hole Placement

All overall lengths shown are nominal dimensions.

Hanger Holes: MAIN TEES – $\frac{3}{4}$ " each side of cross tee slot, and 2 additional holes equally spaced between cross tee slots.

CROSS TEES – $\frac{3}{4}$ " each side of cross tee slot, and 2 additional holes equally spaced between cross tee slots, in all cross tees having slots.

4000 Tempra™ 9/16"

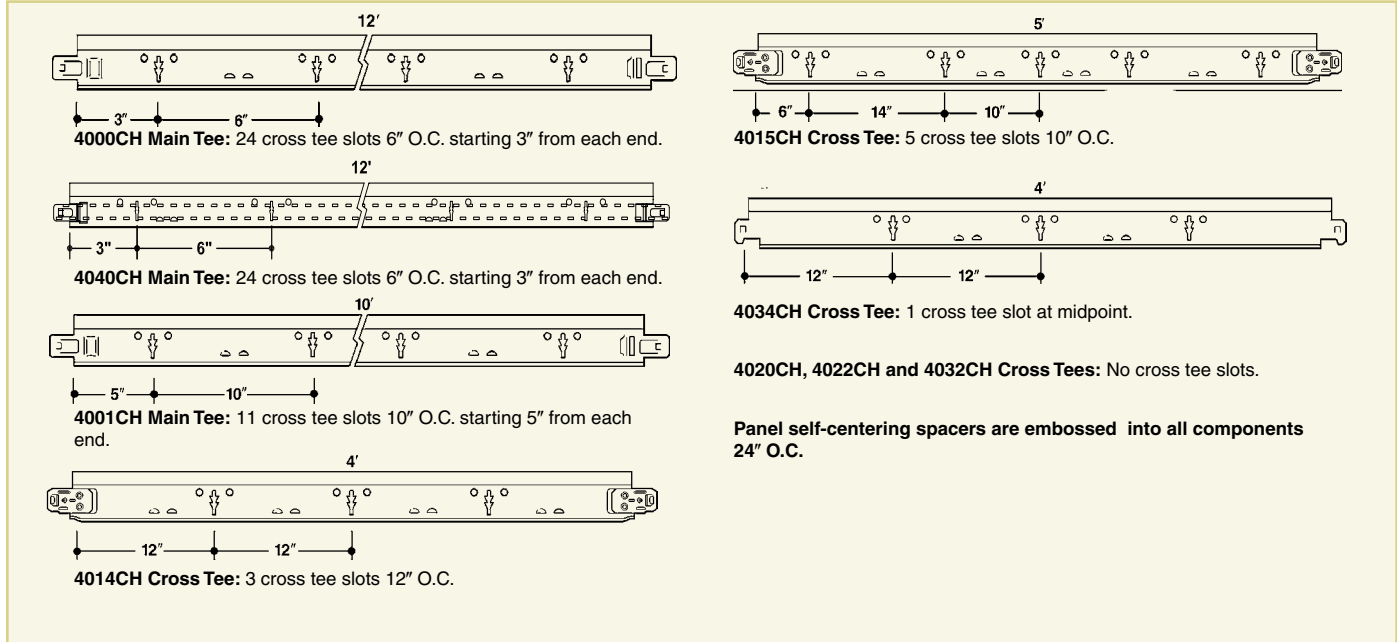

4050 Tempra™ 9/16" Fire-Rated

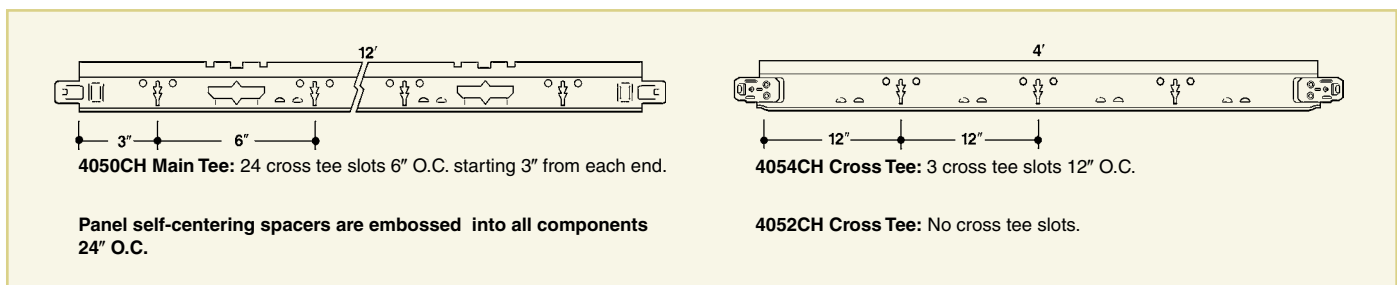

Components 4000 Tempra™ 9/16"

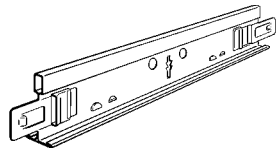

4000CH-4001CH

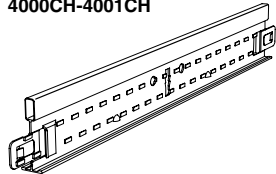

4040CH

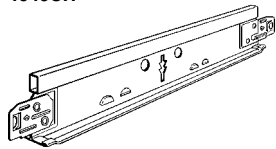

4020CH-4022CH (No slots)
4014CH-4015CH

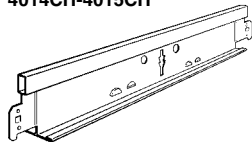

4032CH-4034CH

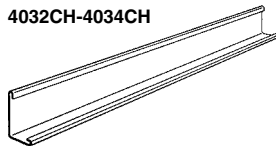

1460-1461-1469

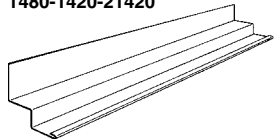

1460-1461-1469

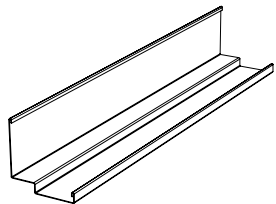

1466

Product Number	Dimensions			ASTM Duty	Per Carton			Service Level
	Length	Height	Face		Feet	Pieces	Weight	

01 White Finish

Main Tees

4000.01CH	12'	1 1/2"	9/16"	ID	360	30	83	0
4040.01CH	12'	1 5/8"	9/16"	HD	240	20	84	0
4001.01CH	10'	1 1/2"	9/16"	ID	300	30	74	0

Cross Tees - Stab - Override

4020.01CH	20"	1 1/2"	9/16"	-	167	100	30	1
4022.01CH <i>Quick-Click®</i>	2'	1 1/2"	9/16"	-	200	100	35	0
4014.01CH <i>Quick-Click®</i>	4'	1 1/2"	9/16"	-	240	60	54	0
4015.01CH	5'	1 1/2"	9/16"	-	300	60	68	1

Cross Tees - Hook - Butt Cut

4032.01CH	2'	1 1/2"	9/16"	-	200	100	35	0
4034.01CH	4'	1 1/2"	9/16"	-	200	60	55	0

Wall Angles

1480.01	12' x 15/16" x 9/16"	-	300	25	39	0
1420.01	12' x 15/16" x 15/16"	-	504	42	69	0
21420.01	12' x 15/16" x 9/16"	-	300	25	41	0

Wall Moldings

1460.01	10' x 3/4" x 3/8" x 3/8" x 3/4"	-	400	40	64	0
1461.01	10' x 3/4" x 3/4" x 3/4" x 3/4"	-	400	40	90	1
1466.01	12' x 1 3/4" x 3/4" x 1/4" x 1 1/4"	-	240	20	61	1
1469.01	10' x 9/16" x 3/8" x 3/8" x 15/16"	-	400	40	77	1

Hanger Wire

96CTL144	12' straight bundled	-	-	-	50	0
----------	----------------------	---	---	---	----	---

Components 4050 Tempra™ 9/16" Fire-Rated

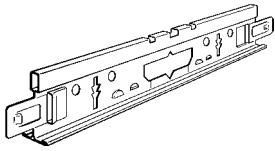

4050CH

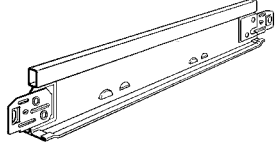

4052CH

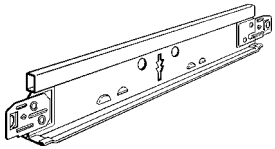

4054CH

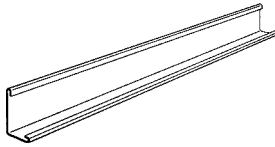

1480-1420-21420

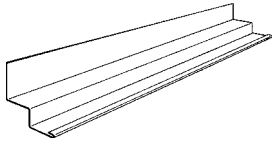

1460-1461-1469

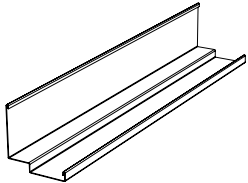

1466

Product Number	Dimensions			ASTM Duty	Per Carton			Service Level
	Length	Height	Face		Feet	Pieces	Weight	
Main Tees								
4050.01CH	12'	1 1/2"	9/16"	ID	360	30	93	1
Cross Tees - Stab - Override								
4052.01CH	2'	1 1/2"	9/16"	-	200	100	51	1
4054.01CH	4'	1 1/2"	9/16"	-	240	60	59	1
Wall Angles								
1480.01	12' x 15/16" x 9/16"			-	300	25	39	0
1420.01	12' x 15/16" x 15/16"			-	504	42	69	0
21420.01	12' x 15/16" x 15/16"			-	300	25	41	0
Wall Moldings								
1460.01	10' x 3/4" x 3/8" x 3/8" x 3/4"			-	400	40	64	0
1461.01	10' x 3/4" x 3/4" x 3/4" x 3/4"			-	400	40	90	1
1466.01	12' x 1 3/4" x 3/4" x 1/4" x 1 1/4"			-	240	20	61	1
1469.01	10' x 9/16" x 3/8" x 3/8" x 15/16"			-	400	40	77	1
Hanger Wire								
96CTL144	12' straight bundled				-	-	50	0

Component Performance Data

Component Load Test Data (based on $1/360$ span deflection)

Tempra™ 4000

ALLOWABLE LOAD per ASTM C635 ▣

Main Tee	Length	Hanger Spacing				
		4'	5'	6'		
4000CH	12'	ID	6.4	3.8		
4040CH	12'	HD	8.8	5.3		
4001CH	10'	ID	6.4	3.8		
Cross Tee	Length	2'	3'	4'	5'	8'
4022CH	2'	24.5 [▲]				
4032CH	2'	24.5 [▲]				
4014CH	4'			12.9		
4034CH	4'			12.9		
4015CH	5'				6.5	

▣ To convert data into lb/ft², divide on center spacing of component into lb/ft.
▲ Weight limited by a safety factor of 2.

Tempra™ 4050 Fire Rated

ALLOWABLE LOAD per ASTM C635 ▣

Main Tee	Length	Hanger Spacing	
		2'	4'
4050CH	12'	ID	
Cross Tee	Length	2'	4'
4052CH	2'	45.0 [▲]	
4054CH	4'		12.9

▣ To convert data into lb/ft², divide on center spacing of component into lb/ft.
▲ Weight limited by a safety factor of 2.

Non-Fire Rated Assemblies

Hanger Positions for Non-Fire Rated Situations
This illustrates hanger positions for single fixtures in a field.

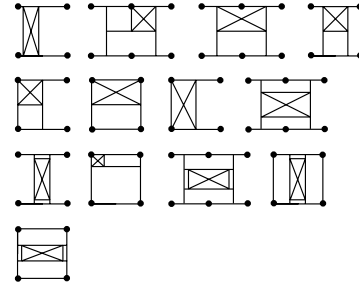

Provide extra hangers for tandem fixtures.

Fire Rated Assemblies

Hanger Positions for Fire Rated Situations

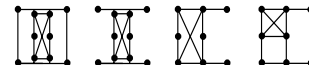

This illustrates hanger positions for single fixtures in a field and are covered in the table. Refer to specific design numbers for allowable number of fixtures per square footage of ceiling area.

Light Fixture Load Test Data (based on $1/360$ span deflection)

LIGHT FIXTURES

MAIN & CROSS TEES - ALLOWABLE FIXTURE WT. – LBS.

Dimensions	4000			4050
	4000CH	4014CH	4015CH	4050.01CH 4054.01CH
1' x 4'	42.4	45.6		
2' x 2'	38.8			38.8
2' x 4'	49.6	44.0 [▲]		49.6
20" x 48"		35.0	35.0	
20" x 60"		35.0	35.0	

Specification Data

suspension type		4000 Tempra	4050 Tempra Fire Rated
material	body	HD Galvanized	•
	cap	HD Galvanized or Aluminum	•
size	width	9/16"	9/16"
	height	1 1/2"	1 1/2"
fire	fire rated ¹		•
performance	heavy duty per ASTM C 635	•	
	intermediate duty per ASTM C 635	•	•
	demountable	•	
seismic	zones / categories - main tees - 1, 2, 3, 4 / A, B, C, D, E, F	•	•
	zones / categories - stab cross tees - 1, 2, 3, 4 / A, B, C, D, E, F	•	•
	zones / categories - hook cross tees - 1, 2 / A, B, C	•	
warranty	40 year limited	•	•
sustainability	Minimum 25% recycled content, 100% locally recyclable, global/regional manufacture	•	•

1 - Tempra grid products have a Class A approved, factory painted, baked-on finish.

Palletization

Product Number	Cartons Per Pallet	Weight Per Pallet	LF Per Pallet
Main Tees			
4000.01CH	28	2,310	10,080
4001.01CH	28	2,058	8,400
4040.01CH	30	2,520	7,200
4050.01CH	28	2,590	10,080
5 Ft. Cross Tee			
4015.01CH	30	2,040	9,000
4 Ft. Cross Tees			
4014.01CH	40	2,160	9,600
4034.01CH	40	2,200	8,000
4054.01CH	40	2,340	8,000
2 Ft. Cross Tees			
4022.01CH	50	1,750	10,000
4032.01CH	50	1,750	10,000
4052.01CH	50	2,550	10,000
20 In. Cross Tee			
4020.01CH	Packaged To Order		

Product Number	Product Length	Cartons Per Pallet	Weight Per Pallet	LF Per Pallet
Wall Angles / Moldings				
Angles				
1420.01	12	30	2,070	15,120
1480.01	12	30	1,170	9,000
21420.01	12	30	1,230	9,000
Shadow Moldings				
1460.01	10	32	2,048	12,800
1461.01	10	32	2,880	12,800
1466.01	12	20	1,220	4,800
1469.01	10	Packaged To Order		

Accessories

Exposed Tee Systems

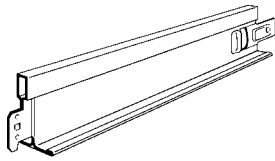

288

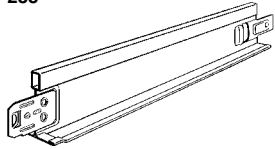

1288

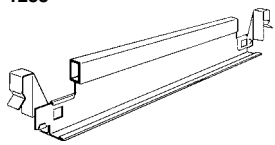

816-817



425

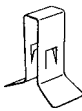

820

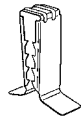

935



416



415

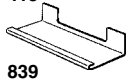

839



426-427

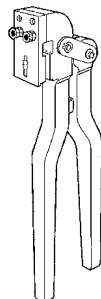

937

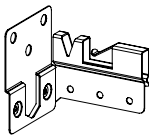

1496

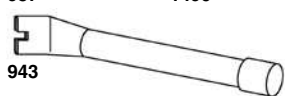

943



944

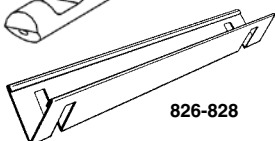

826-828

Product Number	Dimensions			Ft	Per Carton		Service Levels
	Length	Recess	Flanges		Pcs	Wt	
Grid Adapter – To change Main Tee direction 90°							
288.01H	9"	1 1/2"	15/16"	–	50	10	1
1288.01H	9"	1 1/2"	15/16"	–	50	10	1

One end has main Tee coupling and the other end has a cross tee tab.

Variable Placement Cross Tees – To support acoustical material only							
816.01H	2'	1 1/2"	15/16"	80	40	21	1
817.01H	4'	1 1/2"	15/16"	160	40	40	1

Hanger Wire							
96CTL144	12'	straight bundled		–	–	–	0

Product Number	Description	Per Carton			Service Levels
		Ft	Pcs	Wt	

Hold Down Clips						
425.01	For 5/8" board - 250/1200 Systems		–	200	2	0
820.00	For 5/8" board - 250/1250 Systems		–	1000	7	0
935.00	For various board heights for rectangular bulb grid systems		–	1000	16	0

Intersection Clip						
415.00	Locks Spacer Clips to components		–	1000	9	0
416.00	For hook-type cross tee components		–	1000	9	0

Expansion Coupling Cover						
839.01	Covers expansion joints		–	50	9	0

Cross Tee Slotter						
937.00	For "T" type Systems		–	1	3	0

Retention Clips						
426.00	For 1" thick panels		–	200	15	0
427.00	For 1" to 2" thick panels		–	150	15	0

Cross Tee Removal Tool						
943.00			–	1	1	0

Wire Tie Tool						
944.00			–	100	10	0

Seismic Perimeter Clip						
1496.00	For "T" type Systems		–	1	3	0

Spacer Bars							
826.00H	2'	For rectangular bulb components		80	40	15	1
828.00H	4'	For rectangular bulb components		160	40	29	1
824.00H	4'	notched 2' For rectangular bulb components		160	40	29	1



200 Snap-Grid™

PART 1 - GENERAL

1.01 Section Includes

Provide metal suspension system for lay-in acoustical panel ceiling.

1.02 Related Sections

- A. Section 09 22 26 - Suspension Systems
- B. Section 09 54 00 - Specialty Ceilings
- C. Section 09 58 00 - Integrated Ceiling Assemblies
- D. Section 13 48 00 - Sound, Vibration, and Seismic Control
- E. Section 23 50 00 - Central Heating Equipment
- F. Section 26 50 00 - Lighting

1.03 References

- A. American Society for Testing and Materials (ASTM)
 1. C635 - Standard Specification for the manufacture, performance, and testing of Metal Suspension Systems for Acoustical Tile and Lay-in Panel Ceilings.
 2. C636 - Standard Practice for Installation of Metal Ceiling Suspension Systems for Acoustical Tile and Lay-in Panels.

1.04 Submittals

- A. Product data sheets listing dimensions, load carrying capacity and standards compliance.
- B. 12 inch long samples of Main Tees and Cross Tees with integral couplings.

1.05 Project Conditions

- A. Environmental Requirements:
 1. Verify weather tightness of area receiving suspension system prior to installation.
 2. Wet trades work to be thoroughly dry and complete prior to installation.
 3. Installation to begin only when temperature and humidity conditions closely approximate interior conditions which will exist when area is complete and occupied.
 4. Heating and air conditioning systems to be operating prior to, during, and after installation.

1.06 Maintenance

Furnish additional material equal to _____ percent of ceiling area.

PART 2 - PRODUCTS

2.01 Manufacturers

Chicago Metallic double web (Intermediate) (Heavy) duty non-fire rated ceiling suspension system.

2.02 Suspension System Components

- A. Main Tees:
 1. Manufactured from commercial quality steel ¹⁵/₁₆ inch wide by ¹/₂ inches high with factory punched cross tee slots, hanger holes, and integral bayonet-style end couplings.
 2. Capped with steel capping affixed to ¹⁵/₁₆ inch wide flange.
 3. Coated with factory applied baked-on enamel paint from manufacturer's standard selection.
- B. Cross Tees:
 1. Manufactured from commercial quality steel ¹⁵/₁₆ inch wide by ¹/₂ inch high with factory punched cross tee slots, hanger holes, and integral snap-grid end couplings.
 2. Capped identical to main tees.
 3. Finish identical to main tees.
- C. Perimeter Treatment Components:
 1. Angle Moldings: Manufactured from commercial quality steel with hemmed edges finished identical to main tees and cross tees.
 2. Channel Moldings: Manufactured from commercial quality steel with factory applied standard white baked-on enamel paint finish.
 3. Shadow Line Moldings:
 - a. Manufactured from commercial quality steel with ³/₄ inch flanges and ³/₄ inch steps with exposed hemmed edge. Finished with factory applied standard baked-on enamel paint finish.

PART 3 - EXECUTION

3.01 Examination

Examine area receiving suspension system to identify conditions which will adversely affect installation. Do not begin installation until adverse conditions have been remedied.

3.02 Installation

- A. Main Tees: Installed (36) (48) (60) (96) inches on center, by direct suspension from existing structure, with not less than 12 gage steel hanger wires, wrapped tightly 3 full turns, spaced (48) (60) inches on center along component length.
- B. Cross Tees:
 1. Installed perpendicular to main tees (12) (20) (24) (30) (48) (60) (72) (96) (120) inches on center to form _____ by _____ modules.
 2. Installed perpendicular to module forming cross tees (12) (20) (24) (30) inches on center to form _____ by _____ modules.
 3. Installed adjacent to each unsupported side of recessed fixtures.
- C. (Angle) (Channel) (Shadow Line) Moldings: Installed on vertical surfaces, intersecting suspension components by appropriate method in accordance with industry accepted practice.
- D. Additional Hanger Wires: Wrapped tightly 3 full turns to structure and components at locations where imposed loads could cause deflection exceeding ¹/₃₆₀ span.

3.03 Repair

- A. Remove damaged components, replace with undamaged components. Clean with non-solvent based non-abrasive commercial cleaning solution.

250 Fire-Front Snap-Grid™

PART 1 - GENERAL

1.01 Section Includes

Provide metal suspension system for lay-in acoustical panel ceiling.

1.02 Related Sections

- A. Section 09 22 26 - Suspension Systems
- B. Section 09 54 00 - Specialty Ceilings
- C. Section 09 58 00 - Integrated Ceiling Assemblies
- D. Section 13 48 00 - Sound, Vibration, and Seismic Control
- E. Section 23 50 00 - Central Heating Equipment
- F. Section 26 50 00 - Lighting

1.03 References

- A. American Society for Testing and Materials (ASTM)
 1. C635 - Standard Specification for the manufacture, performance, and testing of Metal Suspension Systems for Acoustical Tile and Lay-in Panel Ceilings.
 2. C636 - Standard Practice for Installation of Metal Ceiling Suspension Systems for Acoustical Tile and Lay-in Panels.

- B. Underwriters Laboratories (UL) Fire Resistance Directory (latest edition)

1.04 Submittals

- A. Product data sheets listing dimensions, load carrying capacity and standards compliance.
- B. 12 inch long samples of Main Tees and Cross Tees with integral couplings.

1.05 Project Conditions

- A. Environmental Requirements:
 1. Verify weather tightness of area receiving suspension system prior to installation.
 2. Wet trades work to be thoroughly dry and complete prior to installation.
 3. Installation to begin only when temperature and humidity conditions closely approximate interior conditions which will exist when area is complete and occupied.
 4. Heating and air conditioning systems to be operating prior to, during, and after installation.

1.06 Maintenance

Furnish additional material equal to _____ percent of ceiling area.

PART 2 - PRODUCTS

2.01 Manufacturers

Chicago Metallic double web (Intermediate) (Heavy) duty fire rated ceiling suspension system.

2.02 Suspension System Components

- A. Main Tees:
 1. Manufactured from commercial quality galvanized steel ¹⁵/₁₆ inch wide by ¹/₂ inches high by 144 inches long with factory punched cross tee slots, hanger holes, and integral bayonet-style end couplings.
 2. Capped with steel capping affixed to ¹⁵/₁₆ inch wide flange.
 3. Coated with factory applied color selected from manufacturer's standard offering.
 4. Manufactured with fire expansion reliefs.
- B. Cross Tees:
 1. Manufactured from commercial quality galvanized steel ¹⁵/₁₆ inch wide by ¹/₂ inch high by (24) (36) (48) (60) inches long with factory punched cross tee slots, hanger holes, and integral snap-grid end couplings.
 2. Capped identical to main tees.
 3. Finish identical to main tees.
 4. Manufactured with fire expansion reliefs.
- C. Perimeter Treatment Components:
 1. Angle Moldings: Manufactured from commercial quality galvanized steel ¹⁵/₁₆ inch wide by ¹⁵/₁₆ inch high by (120) (144) inches long with hemmed edges finished identical to main tees and cross tees.
 2. Channel Moldings: Manufactured from commercial quality galvanized steel with factory applied standard white baked-on enamel paint finish. Note: Specifier to select from channels offered by Chicago Metallic.
 3. Shadow Moldings:
 - a. Manufactured from commercial quality galvanized steel with ³/₄ inch flanges, ³/₄ inch recess and exposed hemmed edge. Finished with factory applied standard baked-on enamel paint finish.

PART 3 - EXECUTION

3.01 Examination

Examine area receiving suspension system to identify conditions which will adversely affect installation. Do not begin installation until adverse conditions have been remedied.

3.02 Installation

- A. Suspension System Components: Installed in accordance with U.L design number _____ guidelines.
- B. Main Tees: Installed (36) (48) (60) (96) inches on center, by direct suspension from existing structure, with not less than 12 gage steel hanger wires, wrapped tightly 3 full turns, spaced (48) (60) inches on center along component length.
- C. Cross Tees:
 1. Installed perpendicular to main tees (12) (20) (24) (30) (48) (60) inches on center to form _____ by _____ modules.
 2. Installed perpendicular to module forming cross tees (12) (20) (24) (30) inches on center to form _____ by _____ modules.
 3. Installed adjacent to each unsupported side of recessed fixtures.
- D. (Angle) (Channel) (Shadow) Moldings: Installed on vertical surfaces, intersecting suspension components by appropriate method in accordance with industry accepted practice.
- E. Additional Hanger Wires: Wrapped tightly 3 full turns to structure and components at locations where imposed loads could cause deflection exceeding ¹/₃₆₀ span.

3.03 Repair

- A. Remove damaged components, replace with undamaged components. Clean with non-solvent based non-abrasive commercial cleaning solution.

Seismic 1200 & 1200

PART 1 - GENERAL

1.01 Section Includes

Provide metal suspension system for lay-in acoustical panel ceiling.

1.02 Related Sections

- A. Section 09 22 26 - Suspension Systems
- B. Section 09 54 00 - Specialty Ceilings
- C. Section 09 58 00 - Integrated Ceiling Assemblies
- D. Section 13 48 00 - Sound, Vibration, and Seismic Control
- E. Section 23 50 00 - Central Heating Equipment
- F. Section 26 50 00 - Lighting

1.03 References

- A. American Society for Testing and Materials (ASTM)
 1. C635 - Standard Specification for the manufacture, performance, and testing of Metal Suspension Systems for Acoustical Tile and Lay-in Panel Ceilings.
 2. C636 - Standard Practice for Installation of Metal Ceiling Suspension Systems for Acoustical Tile and Lay-in Panels.
 3. IBC-2006 Section 1613, ASCE7-05 Section 13.5.6 and CISCA "Recommendations For Direct Hung Acoustical Tile And Lay-In Panel Ceilings - Seismic Zones 0-2" May 2004
 4. IBC-2006 Section 1613, ASCE7-05 Section 13.5.6 and CISCA "Guidelines For Seismic Restraint For Direct Hung Suspended Ceiling Assemblies - Seismic Zones 3 & 4" May 2004.

1.04 Submittals

- A. Product data sheets listing dimensions, load carrying capacity and standards compliance.
- B. Samples: 12 inch long samples of main tee and cross tee with couplings.

1.05 Project Conditions

- A. Environmental Requirements:
 1. Verify weather tightness of area to receive suspension system prior to installation.
 2. Wet trades work to be thoroughly dry and complete prior to suspension system installation.
 3. Installation to begin only when temperature and humidity conditions closely approximate interior conditions which will exist when area is complete and occupied.
 4. Heating and air conditioning systems to be operating prior to, during, and after installation.

1.06 Maintenance

Furnish additional material equal to ____ percent of ceiling area.

PART 2 - PRODUCTS

2.01 Manufacturers

Chicago Metallic (Intermediate)(Heavy) duty non-rated double web suspension system.

2.02 Suspension System Components

- A. Main Tees:
 1. Manufactured from commercial quality steel $1\frac{1}{16}$ inch wide by $1\frac{1}{2}$ inches high by (120)(144) inches long with factory punched cross tee slots, hanger holes, and integral bayonet-style end couplings.
 2. Capped with steel capping affixed to $1\frac{1}{16}$ inch flange.
 3. Coated with factory applied (standard [architect select color] baked-on enamel paint).
- B. Cross Tees:
 1. Manufactured from commercial quality steel $1\frac{1}{16}$ inch wide by $1\frac{1}{2}$ inches high by (12)(20)(24)(30)(36)(48)(60)(72)(96)(120) inches long with factory punched cross tee slots and hanger holes.
 2. Capped identical to main tees.
 3. Coated identical to main tees.
 4. Manufactured with factory attached stainless steel stab-in end couplings on component ends (stab-in coupling on one end, integral separation joint on other end).
- C. Perimeter Treatment Components:
 1. Angle Moldings: Manufactured from 0.020 inch thick steel $(\frac{3}{4})(\frac{5}{16})(\frac{7}{8})(2)$ inch wide by $(\frac{1}{2})(\frac{3}{4})(1)(2)$ inch high by (120)(144) inches long, finished identical to main tees and cross tees.
 2. Channel Moldings: Manufactured from 0.018 inch thick steel with factory applied standard white baked-on enamel paint finish. Note: Specifier to select from channels offered by Chicago Metallic.
 3. Shadow Line Moldings: Manufactured from 0.020 inch thick steel with $\frac{3}{4}$ inch and $\frac{3}{8}$ inch hemmed edge. Finished with factory applied standard baked-on enamel paint finish.
 4. Seismic Perimeter Clips: Manufactured from commercial quality steel with gold finish sized to fit $1\frac{1}{2}$ inch high ceiling grid components and clip to minimum $(\frac{7}{8})(\frac{5}{16})(2)$ inch wide wall angle support with minimum $(\frac{3}{4})(\frac{3}{4})$ inch clearance at perimeter walls and ceiling penetrations per IBC 2006 Seismic Design Category (C) (D, E, F).

PART 3 - EXECUTION

3.01 Examination

Examine area receiving suspension system to identify conditions which will adversely affect installation. Do not begin installation until adverse conditions have been remedied.

3.02 Installation

- A. Main Tees: Installed (24)(36)(48)(60)(96) inches on center, by direct suspension from existing structure, with not less than 12 gage steel hanger wires spaced (36)(48)(60) inches on center along main tee length. Wrap hanger wires tightly 3 full turns at each end.
- B. Cross Tees:
 1. Manufactured from commercial quality steel $1\frac{1}{16}$ inch wide by $1\frac{1}{2}$ inches high by (12)(20)(24)(30)(36)(48)(60)(72)(96)(120) inches long $1\frac{1}{16}$ inches high by (24)(48) inches long with factory punched cross tee slots and hanger holes.
 2. Installed perpendicular to module forming cross tees to form _____ by _____ modules.
 3. Installed adjacent to each unsupported side of recessed fixtures.
- C. SST™ Cross Tees:
 1. Installed aligning two seismic separation ends perpendicular to main tees and connecting them together using two plastic push rivets (12)(20)(24)(30)(36)(48)(60)(72)(120) inches on center to form _____ by _____ modules.
 2. Installed perpendicular to module forming cross tees to form _____ by _____ modules.
 3. Installed adjacent to each unsupported side of recessed fixtures.
- D. (Angle)(Channel)(Shadow Line) moldings: Installed on vertical surfaces, intersecting suspension components, by appropriate method in accordance with industry accepted practice.
- E. Additional Hanger Wires: Wrapped tightly 3 full turns to structure and component at locations where imposed loads could cause deflection exceeding $\frac{1}{360}$ span.

3.03 Repair

- A. Remove damaged components, replace with undamaged components. Clean with non-solvent based non-abrasive commercial cleaning solution.

1250 Fire-Front®

PART 1 - GENERAL

1.01 Section Includes

Provide metal suspension system for lay-in acoustical panel ceiling.

1.02 Related Sections

- A. Section 09 22 26 - Suspension Systems
- B. Section 09 54 00 - Specialty Ceilings
- C. Section 09 58 00 - Integrated Ceiling Assemblies
- D. Section 13 48 00 - Sound, Vibration, and Seismic Control
- E. Section 23 50 00 - Central Heating Equipment
- F. Section 26 50 00 - Lighting

1.03 References

- A. American Society for Testing and Materials (ASTM)
 1. C635 - Standard Specification for the manufacture, performance, and testing of Metal Suspension Systems for Acoustical Tile and Lay-in Panel Ceilings.
 2. C636 - Standard Practice for Installation of Metal Ceiling Suspension Systems for Acoustical Tile and Lay-in Panels.
- B. Underwriters laboratories (UL) _____ Fire Resistance Directory (latest edition)

1.04 Submittals

- A. Product data sheets listing dimensions, load carrying capacity and standards compliance.
- B. 12 inch long samples of Main Tees and Cross Tees with integral couplings.

1.05 Project Conditions

- A. Environmental Requirements:
 1. Verify weather tightness of area to receive suspension system prior to installation.
 2. Wet trades work to be thoroughly dry and complete prior to suspension system installation.
 3. Installation to begin only when temperature and humidity conditions closely approximate interior conditions which will exist when area is complete and occupied.
 4. Heating and air conditioning systems to be operating prior to, during, and after installation.

1.06 Maintenance

Furnish additional material equal to ____ percent of ceiling area.

PART 2 - PRODUCTS

2.01 Manufacturers

Chicago Metallic (Intermediate) (Heavy) duty fire rated double web suspension system.

2.02 Suspension System Components

- A. Main Tees:
 1. Manufactured from commercial quality galvanized steel $1\frac{1}{16}$ inch wide by $1\frac{1}{2}$ inches high by 144 inches long with factory punched cross tee slots, hanger holes, and integral bayonet-style end couplings.
 2. Capped with steel capping affixed to $1\frac{1}{16}$ inch flange.
 3. Coated with factory applied color selected from manufacturer's standard offering.
- B. Cross Tees:
 1. Manufactured from commercial quality galvanized steel $1\frac{1}{16}$ inch wide by $1\frac{1}{2}$ inches high by (24)(36)(48)(60) inches long with factory punched cross tee slots and hanger holes.
 2. Capped identical to main tees.
 3. Coated identical to main tees.
 4. Manufactured with factory attached stainless steel couplings on component ends.
- C. Perimeter Treatment Components:
 1. Angle Moldings: Manufactured from commercial quality galvanized steel $1\frac{1}{16}$ inch wide by $1\frac{1}{16}$ inch high by (120)(144) inches long with hemmed edges finished identical to main tees and cross tees.
 2. Channel Moldings: Manufactured from commercial quality galvanized steel with factory applied standard white baked-on enamel paint finish. Note: Specifier to select from channels offered by Chicago Metallic.
 3. Shadow Moldings:
 - a. Manufactured from commercial quality galvanized steel with $\frac{3}{4}$ inch flanges, $\frac{3}{4}$ inch recess and exposed hemmed edge. Finished with factory applied standard baked-on enamel paint finish.

PART 3 - EXECUTION

3.01 Examination

Examine area receiving suspension system to identify conditions which will adversely affect installation. Do not begin installation until adverse conditions have been remedied.

3.02 Installation

- A. Suspension System Components: Installed in accordance with UL design number _____ guidelines.
- B. Main Tees: Installed (36)(48)(60) inches on center, by direct suspension from existing structure, with not less than 12 gage steel hanger wires spaced (48)(60) inches on center along main tee length. Wrap hanger wires tightly 3 full turns at each end.
- C. Cross Tees:
 1. Installed perpendicular to main tees (12)(20)(24)(30)(36)(48)(60) inches on center to form _____ by _____ modules.
 2. Installed perpendicular to module forming cross tees to form _____ by _____ modules.
 3. Installed adjacent to each unsupported side of recessed fixtures.
- D. (Angle)(Channel)(Shadow) moldings: Installed on vertical surfaces, intersecting suspension components, by appropriate method in accordance with industry accepted practice.
- E. Additional Hanger Wires: Wrapped tightly 3 full turns to structure and component at locations where imposed loads could cause deflection exceeding $\frac{1}{360}$ span.

3.03 Repair

- A. Remove damaged components, replace with undamaged components. Clean with non-solvent based non-abrasive commercial cleaning solution.



4000 Tempra™

PART 1 - GENERAL

1.01 Section Includes

Provide metal suspension system for acoustical lay-in panel ceiling.

1.02 Related Sections

- A. Section 09 22 26 - Suspension Systems
- B. Section 09 54 00 - Specialty Ceilings
- C. Section 09 29 00 - Gypsum Board
- D. Section 09 58 00 - Integrated Ceiling Assemblies
- E. Section 13 48 00 - Sound, Vibration, and Seismic Control
- F. Section 23 50 00 - Central Heating Equipment
- G. Section 26 50 00 - Lighting

1.03 References

- A. American Society for Testing and Materials (ASTM)
 1. C635 - Standard Specification for the manufacture, performance, and testing of Metal Suspension Systems for Acoustical Tile and Lay-in Panel Ceilings.
 2. C636 - Standard Practice for Installation of Metal Ceiling Suspension Systems for Acoustical Tile and Lay-in Panels.

1.04 Submittals

- A. Product data sheets listing dimensions, load carrying capacity and standards compliance.
- B. Samples: 12 inch long samples of main tee and cross tee with end couplings.

1.05 Project Conditions

- A. Environmental Requirements:
 1. Verify weather tightness of area to receive suspension system prior to installation.
 2. Wet trades work shall be dry and complete prior to installation.
 3. Installation to begin only when temperature and humidity conditions closely approximate interior conditions which will exist when area is complete and occupied.
 4. Heating and air conditioning systems to be operating prior to, during, and after installation.

1.06 Maintenance

Furnish additional material equal to ____ percent of ceiling area.

PART 2 - PRODUCTS

2.01 Manufacturers

Chicago Metallic Tempra 4000 (Intermediate)(Heavy) duty suspension system.

2.02 Suspension System Components

- A. Main Tees:
 1. Manufactured from commercial quality galvanized steel $\frac{9}{16}$ inch wide by $1\frac{1}{2}$ inches by (120) (144) inches long with factory punched cross tee slots, hanger holes, and integral end couplings.
 2. Capped with (steel)(aluminum) with standard factory applied baked-on enamel paint.
 3. Manufactured with ceiling panel centering tabs.
- B. Cross Tees:
 1. Manufactured from commercial quality galvanized steel $\frac{9}{16}$ inch wide by $1\frac{1}{2}$ inches high by (12) (20) (24) (30) (48) (60) inches long with factory punched cross tee slots, hanger holes, and either snap-in or stab-in end tab.
 2. Capped identical to main tees.
 3. Manufactured with ceiling panel centering tabs.
- C. Perimeter Treatment Components:
 1. Angle Moldings: Manufactured from commercial quality galvanized steel ($\frac{9}{16}$)($\frac{15}{16}$) inch wide by $\frac{15}{16}$ inch high by 144 inches long, finished identical to main tees and cross tees.
 2. Shadow Moldings: Manufactured from commercial quality galvanized steel with $\frac{3}{4}$ inch flanges and $\frac{3}{8}$ inch steps coated with factory applied baked-on enamel paint finish identical to main tees and cross tees.

PART 3 - EXECUTION

3.01 Examination

Examine area receiving suspension system to identify conditions which will adversely affect installation. Do not begin installation until adverse conditions have been remedied.

3.02 Installation

- A. Main Tees: Installed (48) (60) inches on center, by direct suspension from existing structure, with not less than 12 gage hanger wires, wrapped tightly 3 full turns, spaced 48 inches on center along component length.
- B. Cross Tees:
 1. Installed perpendicular to main tees (20) (24) (30) (48) (60) inches on center to form _____ by _____ modules.
 2. Installed perpendicular to module forming cross tees (20) (24) (30) inches on center forming _____ by _____ modules.
 3. Installed adjacent to each unsupported side of recessed fixtures.
- C. (Angle) (Shadow) moldings: Installed on vertical surfaces, intersecting main runners and cross tees, by appropriate method in accordance with industry accepted practice.

3.03 Repair

- A. Remove damaged components, replace with undamaged components. Clean with non-solvent based non-abrasive commercial cleaning solution.

4050 Tempra™ Fire Rated

PART 1 - GENERAL

1.01 Section Includes

Provide metal suspension system for acoustical lay-in panel ceiling.

1.02 Related Sections

- A. Section 09 22 26 - Suspension Systems
- B. Section 09 54 00 - Specialty Ceilings
- C. Section 09 29 00 - Gypsum Board
- D. Section 09 58 00 - Integrated Ceiling Assemblies
- E. Section 13 48 00 - Sound, Vibration, and Seismic Control
- F. Section 23 50 00 - Central Heating Equipment
- G. Section 26 50 00 - Lighting

1.03 References

- A. American Society for Testing and Materials (ASTM)
 1. C635 - Standard Specification for the manufacture, performance, and testing of Metal Suspension Systems for Acoustical Tile and Lay-in Panel Ceilings.
 2. C636 - Standard Practice for Installation of Metal Ceiling Suspension Systems for Acoustical Tile and Lay-in Panels.

1.04 Submittals

- A. Product data sheets listing dimensions, load carrying capacity and standards compliance.
- B. Samples: 12 inch long samples of main tee and cross tee with end couplings.

1.05 Project Conditions

- A. Environmental Requirements:
 1. Verify weather tightness of area to receive suspension system prior to installation.
 2. Wet trades work shall be dry and complete prior to installation.
 3. Installation to begin only when temperature and humidity conditions closely approximate interior conditions which will exist when area is complete and occupied.
 4. Heating and air conditioning systems to be operating prior to, during, and after installation.

1.06 Maintenance

Furnish additional material equal to ____ percent of ceiling area.

PART 2 - PRODUCTS

2.01 Manufacturers

Chicago Metallic Fire Front Tempra 4050 Intermediate duty suspension system

2.02 Suspension System Components

- A. Main Tee:
 1. Manufactured from commercial quality galvanized steel $\frac{9}{16}$ inch wide by 1-1/2 inches by (120) (144) inches long with factory punched cross tee slots, hanger holes, and integral bayonet-style end couplings.
 2. Capped with (steel)(aluminum) with standard factory applied baked-on enamel paint.
 3. Manufactured with ceiling panel centering tabs.
 4. Manufactured with fire expansion reliefs on fire rated components.
- B. Cross Tees:
 1. Manufactured from commercial quality galvanized steel $\frac{9}{16}$ inch wide by $1\frac{1}{2}$ inches high by (24) (48) inches long with factory punched cross tee slots, hanger holes, and stab-in end tab.
 2. Capped identical to main tees.
 3. Manufactured with ceiling panel centering tabs.
- C. Perimeter Treatment Components:
 1. Angle Moldings: Manufactured from commercial quality galvanized steel ($\frac{9}{16}$)($\frac{15}{16}$) inch wide by $\frac{15}{16}$ inch high by 144 inches long, finished identical to main tees and cross tees.

PART 3 - EXECUTION

3.01 Examination

Examine area receiving suspension system to identify conditions which will adversely affect installation. Do not begin installation until adverse conditions have been remedied.

3.02 Installation

- A. Suspension System Components: Installed in accordance with UL design number _____ guidelines.
- B. Main Tee: Installed (48) (60) inches on center, by direct suspension from existing structure, with not less than 12 gage hanger wires, wrapped tightly 3 full turns, spaced 48 inches on center along component length.
- C. Cross Tees:
 1. Installed perpendicular to main tees (20) (24) (30) (48) (60) inches on center to form _____ by _____ modules.
 2. Installed perpendicular to module forming cross tees (20) (24) (30) inches on center forming _____ by _____ modules.
 3. Installed adjacent to each unsupported side of recessed fixtures.
- D. (Angle) (Shadow Line) moldings: Installed on vertical surfaces, intersecting main tees and cross tees, by appropriate method in accordance with industry accepted practice.

3.03 Repair

- A. Remove damaged components, replace with undamaged components. Clean with non-solvent based non-abrasive commercial cleaning solution.

4500 & 4550 Ultraline™ Fire Rated 9/16", 1/4" Reveal Bolt Slot and 4600 Ultraline™ 9/16", 1/8" Reveal Bolt Slot

Non-Fire Rated / Fire Rated
Double Web
Direct Hung Exposed

Ultraline 4500 and Fire Front 4550 narrow face significantly diminishes the distinction between grid and panel creating a monolithic ceiling. The slender center regress and crisply mitered intersections result in flawless and continuous lines. Ultraline 4600 more subtly accents the shadow of the center regress.

Applications

Can be used as a more "workable" alternate to concealed ceilings or as an upgrade to standard lay-in ceilings. Black or white center regress available.

Features / Benefits

- **9/16" narrow face** / Minimizes the appearance of the grid creating a monolithic look. Grid and panel on same plane, panel does not lay on top of grid.
- **Designed for reveal-edge panels** / Complete plenum access from any point in the ceiling.
- **Mitered intersections** / Provide crisp continuous lines that create a uniform ceiling plane.
- **Versatility in modular configurations** / Offers additional design possibilities.
- **4600's extremely narrow 1/8" regress** / Accents the shadow while enhancing the monolithic ceiling look.
- **Sustainability** / Minimum 25% recycled content, 100% locally recyclable.
- **Flame Spread Rating** / Chicago Metallic suspension systems meet a Class-A flame spread rating.

Installation Features / Benefits

- **Stab-in cross tees** / Tees cantilever during installation and will not fall out, making for an easier installation. Protects against lateral pull-out.
- **Notch covers** / Conceals unused cross tee notches.
- **Available cut-off notcher** / Saves time in cutting main and cross tees, providing a finished appearance.
- **Double web construction** / Increased strength for better durability.
- **Accommodates standard NEMA Type-SS lights and air diffusers** / Allows for integration of lighting and air supply without creating additional labor.

IMPORTANT! A Metallurgist should be consulted regarding the suitability of this product for the environmental conditions in which it is being installed.

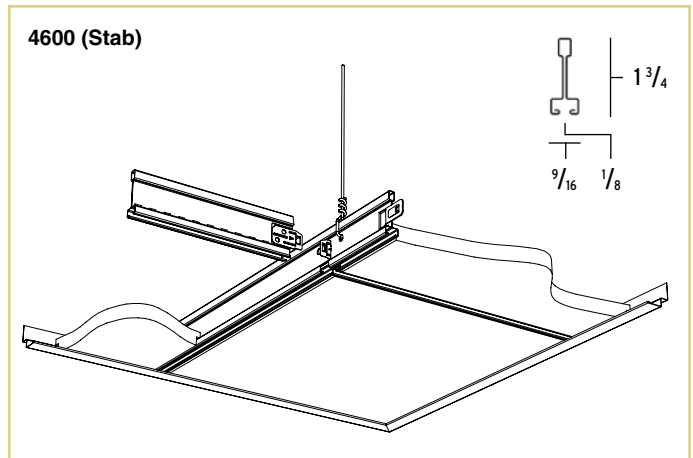
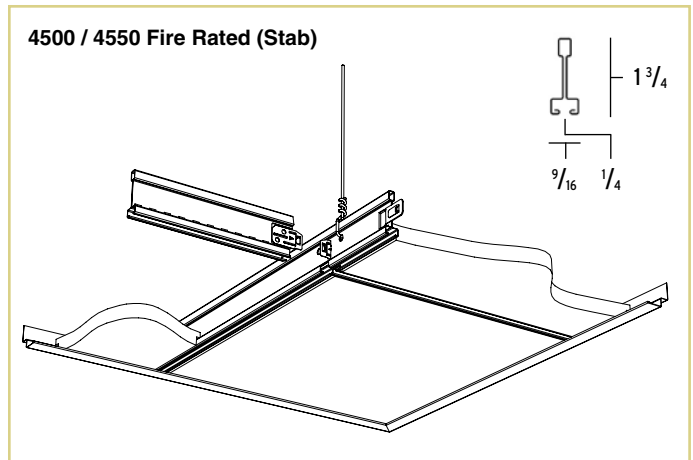

Component Slotting and Hanger Hole Placement

All overall lengths shown are nominal dimensions.

Hanger Holes: MAIN TEES – $\frac{3}{4}$ " each side of cross tee slot, and 2 additional holes equally spaced between cross tee slots.

CROSS TEES – $\frac{3}{4}$ " each side of cross tee slot, and 2 additional holes equally spaced between cross tee slots, in all cross tees having slots.

4500 Ultraline™ 9/16", 1/4" Reveal Bolt Slot

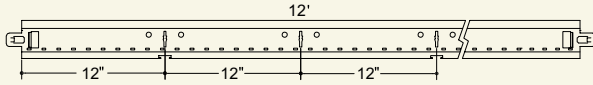

4500 and 4530 Main Tees: 11 cross tee slots with notches, 24" O.C.

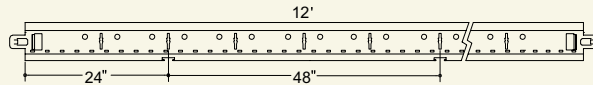

4540 Main Tee: 11 cross tee slots with notches, 48" O.C.

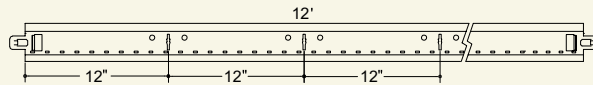

4560 Main Tee: 11 cross tee slots with no notches

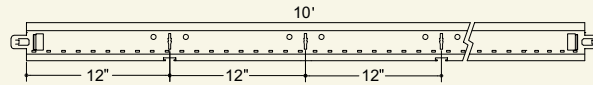

4503 Main Tee: 9 cross tee slots with notches, 24" O.C.

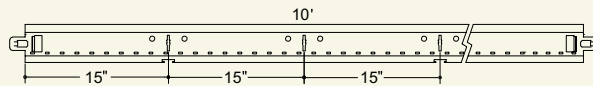

4501 and 4531 Main Tees: 7 cross tee slots with notches, 30" O.C.

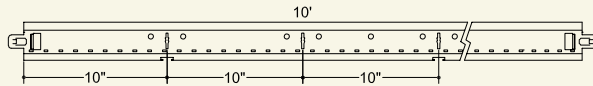

4502 Main Tee: 11 cross tee slots with notches, 20" O.C.

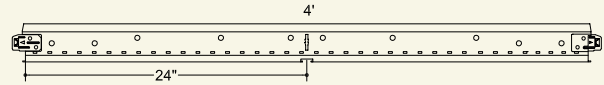

4514 Cross Tee: 1 cross tee slot with notch, 24" O.C.

4518 Cross Tee: 1 cross tee slot with notch one side only, 24" O.C.

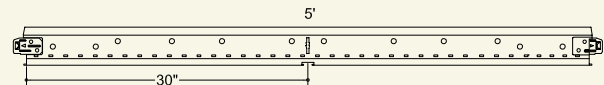

4515 Cross Tee: 1 cross tee slot with notch, 30" O.C.

4519 Cross Tee: 1 cross tee slot with notch one side only, 30" O.C.

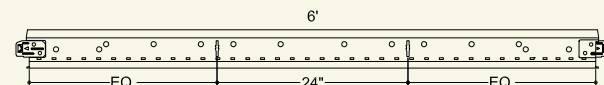

4516 Cross Tee: 2 cross tee slots, no notches.



4528 Cross Tee: 3 cross tee slots, no notches.



4521 Cross Tee: No cross tee slots.



4524 Cross Tee: No cross tee slots.

4511, 4520, 4512 and 4513: No slots, holes or notches.

Components

4500 Ultraline™ 9/16", 1/4" Reveal Bolt Slot

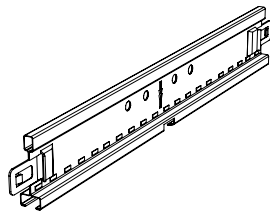

4500-4540-4503-4501-4502
4530-4531
4560 (no notches)

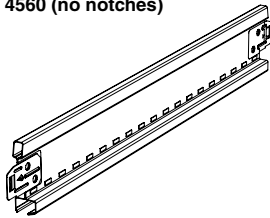

4511-4512-
4520-4513

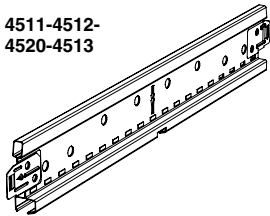

4514-4515-4519-4518

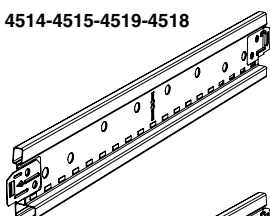

4516-4528

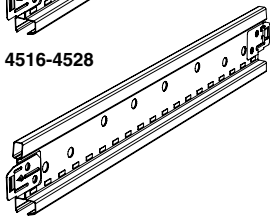

4521-4524

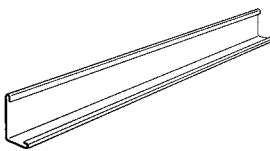

1480-1420-21420-1467

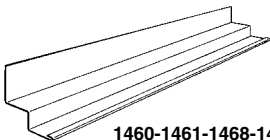

1460-1461-1468-1469

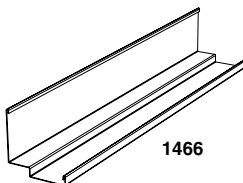

1466

Product Number	Dimensions			ASTM Duty	Per Carton			Service Level
	Length	Height	Face		Feet	Pieces	Weight	

01 White with 1/4" 01 White Reveal

Main Tees

4500.01	12'	1 ³ / ₄ "	9/16"	ID	240	20	60	0
4540.01	12'	1 ³ / ₄ "	9/16"	ID	240	20	60	1
4503.01	10'	1 ³ / ₄ "	9/16"	ID	200	20	51	2
4501.01	10'	1 ³ / ₄ "	9/16"	ID	200	20	51	2
4502.01	10'	1 ³ / ₄ "	9/16"	ID	200	20	51	2
4530.01	12'	1 ³ / ₄ "	9/16"	HD	240	20	73	0
4560.01	12'	1 ³ / ₄ "	9/16"	HD	240	20	79	1
4531.01	10'	1 ³ / ₄ "	9/16"	HD	200	20	66	2

Cross Tees - Stab - Mitered

4511.01	1'	1 ³ / ₄ "	9/16"	-	80	80	20	1
4520.01	20"	1 ³ / ₄ "	9/16"	-	116	70	29	1
4512.01	2'	1 ³ / ₄ "	9/16"	-	140	70	35	0
4513.01	30"	1 ³ / ₄ "	9/16"	-	100	40	26	1
4524.01	4'	1 ³ / ₄ "	9/16"	-	160	40	41	1
4514.01	4'	1 ³ / ₄ "	9/16"	-	160	40	41	0
4518.01	4'	1 ³ / ₄ "	9/16"	-	160	40	41	1
4521.01	5'	1 ³ / ₄ "	9/16"	-	200	40	52	1
4515.01	5'	1 ³ / ₄ "	9/16"	-	200	40	52	1
4519.01	5'	1 ³ / ₄ "	9/16"	-	200	40	52	1
4516.01	6'	1 ³ / ₄ "	9/16"	-	120	20	32	2
4528.01	8'	1 ³ / ₄ "	9/16"	-	160	20	42	2

Wall Angles

1480.01	12' x 9/16" x 15/16"	-	300	25	39	0
1420.01	12' x 15/16" x 15/16"	-	504	42	69	0
21420.01	12' x 15/16" x 15/16"	-	300	25	41	0
1467.01*	12' x 15/16" x 13/16"	-	240	20	39	0

Wall Molding

1460.01	10' x 3/4" x 3/8" x 3/8" x 3/4"	-	400	40	64	0
1461.01	10' x 3/4" x 3/4" x 3/4" x 3/4"	-	400	40	90	1
1466.01	12' x 13/4" x 3/4" x 1/4" x 11/4"	-	240	20	61	1
1468.01*	10' x 3/4" x 3/8" x 3/8" x 15/16"	-	400	40	77	2
1469.01	10' x 9/16" x 3/8" x 3/8" x 15/16"	-	400	40	77	1

Hanger Wire

96CTL144	12' straight bundled	-	-	-	50	0
----------	----------------------	---	---	---	----	---

* To allow for use of Bolt Slot Grid with 1496 Clip

Component Slotting and Hanger Hole Placement

All overall lengths shown are nominal dimensions.

Hanger Holes: MAIN TEES – 3/4" each side of cross tee slot, and 2 additional holes equally spaced between cross tee slots.

CROSS TEES – 3/4" each side of cross tee slot, and 2 additional holes equally spaced between cross tee slots, in all cross tees having slots.

4550 Ultraline™ Fire Rated 9/16", 1/4" Reveal Bolt Slot

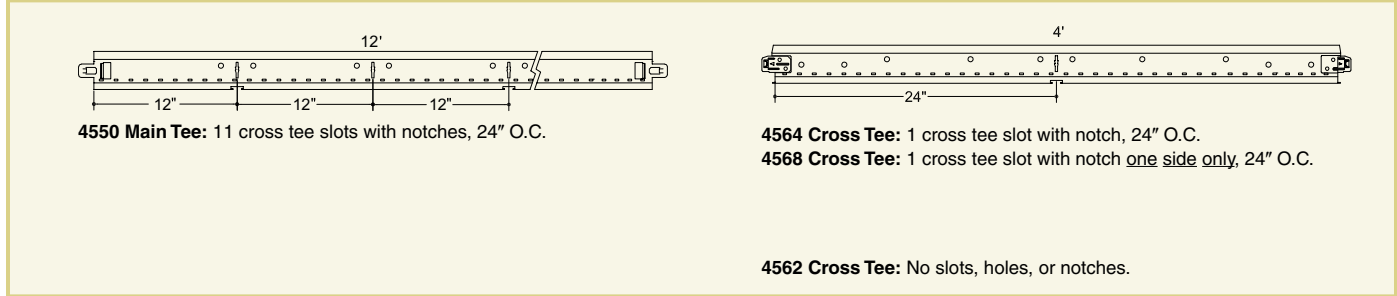

Components 4550 Ultraline™ Fire Rated 9/16", 1/4" Bolt Slot

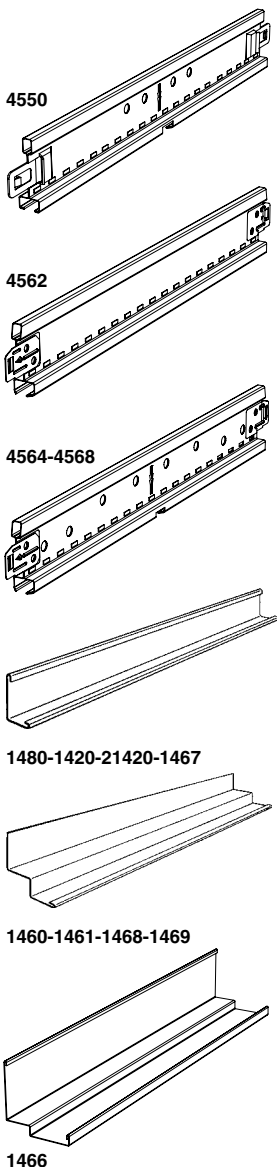

Product Number	Dimensions			ASTM Duty	Per Carton			Service Level
	Length	Height	Face		Feet	Pieces	Weight	
01 White with 1/4" 01 White Reveal								
Main Tee								
4550.01	12'	1 ⁵ / ₈ "	9/16"	ID	240	20	79	1
Cross Tees - Stab - Mitered								
4562.01	2'	1 ⁵ / ₈ "	9/16"	–	140	70	35	1
4564.01	4'	1 ⁵ / ₈ "	9/16"	–	160	40	41	0
4568.01	4'	1 ⁵ / ₈ "	9/16"	–	160	40	41	1
Wall Angles								
1480.01	12' x 1 ⁵ / ₁₆ " x 9/16"			–	300	25	39	0
1420.01	12' x 1 ⁵ / ₁₆ " x 1 ⁵ / ₁₆ "			–	504	42	69	0
21420.01	12' x 1 ⁵ / ₁₆ " x 1 ⁵ / ₁₆ "			–	300	25	41	0
1467.01*	12' x 1 ⁵ / ₁₆ " x 1 ³ / ₁₆ "			–	240	20	39	0
Wall Molding								
1460.01	10' x 3/4" x 3/8" x 3/8" x 3/4"			–	400	40	64	0
1461.01	10' x 3/4" x 3/4" x 3/4" x 3/4"			–	400	40	90	1
1466.01	12' x 1 ³ / ₄ " x 3/4" x 1/4" x 1 ¹ / ₄ "			–	240	20	61	1
1468.01*	10' x 3/4" x 3/8" x 3/8" x 1 ⁵ / ₁₆ "			–	400	40	77	2
1469.01	10' x 9/16" x 3/8" x 3/8" x 1 ⁵ / ₁₆ "			–	400	40	77	1
Hanger Wire								
96CTL144	12' straight bundled			–	–	–	50	0

* To allow for use of Bolt Slot Grid with 1496 Clip

UL® Fire Resistant Designs

Roof and Ceiling Designs – Type 4550
G264, P254

Component Slotting and Hanger Hole Placement

All overall lengths shown are nominal dimensions.

Hanger Holes: MAIN TEES – 3/4" each side of cross tee slot, and 2 additional holes equally spaced between cross tee slots.

CROSS TEES – 3/4" each side of cross tee slot, and 2 additional holes equally spaced between cross tee slots, in all cross tees having slots.

4600 Ultraline™ 9/16", 1/8" Reveal Bolt Slot



4600 and 4630 Main Tees: 11 cross tee slots with notches, 24" O.C.

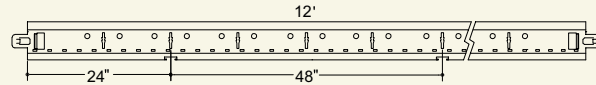

4640 and 4660 Main Tees: 11 cross tee slots with notches, 48" O.C.

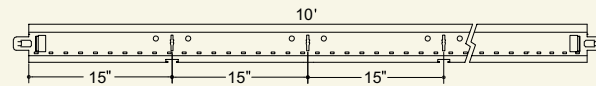

4601 Main Tee: 7 cross tee slots with notches, 30" O.C.

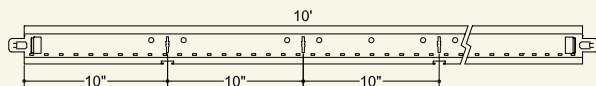

4602 Main Tee: 11 cross tee slots with notches, 20" O.C.

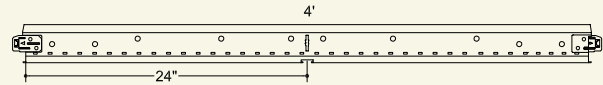

4614 Cross Tee: 1 cross tee slot with notch, 24" O.C.

4618 Cross Tee: 1 cross tee slot with notch one side only, 24" O.C.

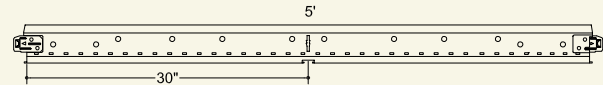

4615 Cross Tee: 1 cross tee slot with notch, 30" O.C.

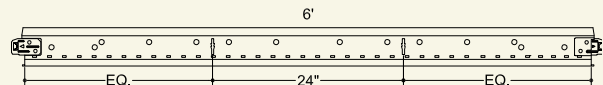

4616 Cross Tee: 2 cross tee slots, no notches.



4628 Cross Tee: 3 cross tee slots, no notches.

4611, 4620, 4612, 4613, 4624, 4621 Cross Tee:
No cross tee slots or notches.

Components

4600 Ultraline™ 9/16", 1/8" Reveal Bolt Slot

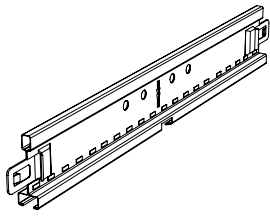

4600-4640-4630-4601-4602

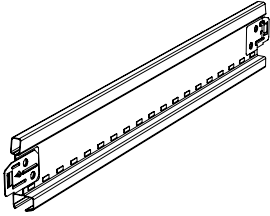

4611-4620-4612-4613-4624
4621-4616-4628

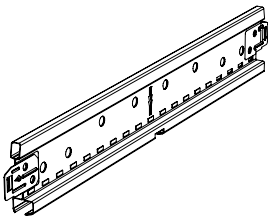

4614-4618-4615

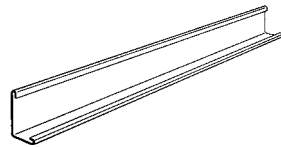

1480-1420-21420-1467

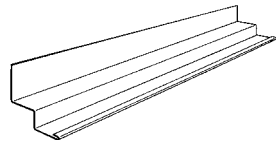

1460-1461-1468-1469

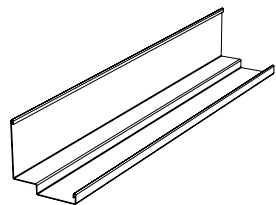

1466

Product Number	Dimensions			ASTM Duty	Per Carton			Service Level
	Length	Height	Face		Feet	Pieces	Weight	

01 White with 1/8" 01 White Reveal

Main Tees

4600.01	12'	1 ⁵ / ₈ "	9/16"	ID	240	20	59	0
4640.01	12'	1 ⁵ / ₈ "	9/16"	ID	240	20	59	0
4630.01	12'	1 ⁵ / ₈ "	9/16"	HD	240	20	81	3
4660.01	12'	1 ⁵ / ₈ "	9/16"	HD	240	20	81	2
4601.01	10'	1 ⁵ / ₈ "	9/16"	ID	200	20	67	3
4602.01	10'	1 ⁵ / ₈ "	9/16"	ID	200	20	67	3

Cross Tees - Stab - Mitered

4611.01	1'	1 ⁵ / ₈ "	9/16"	-	80	80	20	2
4620.01	20"	1 ⁵ / ₈ "	9/16"	-	116	70	29	2
4612.01	2'	1 ⁵ / ₈ "	9/16"	-	140	70	36	0
4613.01	30"	1 ⁵ / ₈ "	9/16"	-	100	40	25	2
4624.01	4'	1 ⁵ / ₈ "	9/16"	-	160	40	41	0
4614.01	4'	1 ⁵ / ₈ "	9/16"	-	160	40	41	0
4618.01	4'	1 ⁵ / ₈ "	9/16"	-	160	40	41	0
4621.01	5'	1 ⁵ / ₈ "	9/16"	-	200	40	49	0
4615.01	5'	1 ⁵ / ₈ "	9/16"	-	200	40	49	0
4616.01	6'	1 ⁵ / ₈ "	9/16"	-	160	40	30	0
4628.01	8'	1 ⁵ / ₈ "	9/16"	-	160	20	39	0

Wall Angles

1480.01	12' x 1 ⁵ / ₁₆ " x 9/16"	-	300	25	39	0
1420.01	12' x 1 ⁵ / ₁₆ " x 1 ⁵ / ₁₆ "	-	504	42	69	0
21420.01	12' x 1 ⁵ / ₁₆ " x 1 ⁵ / ₁₆ "	-	300	25	41	0
1467.01*	12' x 1 ⁵ / ₁₆ " x 1 ³ / ₁₆ "	-	240	20	39	0

Wall Molding

1460.01	10' x 3/4" x 3/8" x 3/8" x 3/4"	-	400	40	64	0
1461.01	10' x 3/4" x 3/4" x 3/4" x 3/4"	-	400	40	90	1
1466.01	12' x 1 ³ / ₄ " x 3/4" x 1/4" x 1 ¹ / ₄ "	-	240	20	61	1
1468.01*	10' x 3/4" x 3/8" x 3/8" x 1 ⁵ / ₁₆ "	-	400	40	77	2
1469.01	10' x 9/16" x 3/8" x 3/8" x 1 ⁵ / ₁₆ "	-	400	40	77	1

Hanger Wire

96CTL144	12' straight bundled	-	-	-	50	0
----------	----------------------	---	---	---	----	---

* To allow for use of Bolt Slot Grid with 1496 Clip

Accessories

Ultraline™ Bolt Slot / Reveal Systems

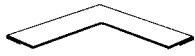

Outside/Square Corner Caps
1332-1334-1341-1344-1340-1351

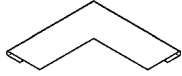

Outside/Radius Corner Caps
1336-1338-1340-1342-1352

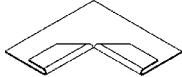

Inside Corner Caps
1346-1347-1348-1350-1353

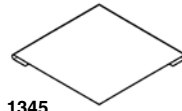

1345

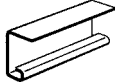

3599-3699

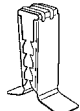

935

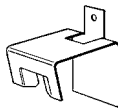

1499

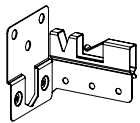

1496

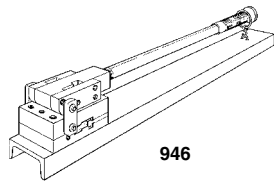

946

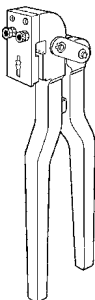

937

Product Number	Description	Per Carton			Service Levels
		Ft	Pcs	Wt	
Corner Caps – Outside/ Square					
1332.01	For 3/4" angle	–	75	2	0
1334.01	For 15/16" angle	–	75	2	0
1341.01	For 9/16" angle	–	75	2	0
1344.01	For 2" angle	–	75	4	0
Corner Caps – Outside/Radius					
1336.01	For 3/4" angle, 3/4" radius	–	75	2	0
1338.01	For 15/16" angle, 3/4" radius	–	75	2	0
1340.01	For 3/4" angle, 1" radius	–	75	2	0
1342.01	For 15/16" angle, 1" radius	–	75	3	0
1351.01	For 7/8" angle, 1/8" radius	–	75	2	0
1352.01	For 7/8" angle, 3/4" radius	–	75	2	0
Corner Caps –Inside					
1346.01	For 3/4" angle	–	75	1	0
1347.01	For 9/16" angle	–	75	2	0
1348.01	For 15/16" angle	–	75	2	0
1350.01	For 2" angle	–	75	4	0
1353.01	For 7/8" angle	–	75	2	0
Blank Square					
1345.01		–	75	3	0
Notch Covers					
3599.01	7/8" L - 4500 System Only	–	100	1	0
3699.01	7/8" L - 4600 System Only	–	100	1	0
Seismic Perimeter Clip					
1496.00	For "T" type Systems	–	1	3	0
Hold Down Clip					
935.00	Adjust to different height board	–	1000	16	0
Perimeter Clip					
1499.00	For 1 1/2" components	–	100	4	0
Cut-Off/End Notcher					
946.00	For 4500 and 4600 Systems	–	1	20	0
Cross Tee Slotter					
937.00	For 4500 and 4600 Systems	–	1	3	0
Hanger Wire					
96CTL144	12' straight bundled	–	–	50	0

Component Performance Data

Component Load Test Data (based on $1/360$ span deflection)

Ultraline™ 4500 $9/16$ " Exposed with $1/4$ " Reveal

ALLOWABLE LOAD per ASTM C635 ▣

Main Tee	Length	Hanger Spacing		
		4'	5'	6'
4500	12'	ID	7.7	4.6
4540	12'	ID	7.7	4.6
4530	12'	HD		
4560	12'	HD		
4503	10'	ID	7.7	4.6
4501	10'	ID	7.7	4.6
4502	10'	ID	7.7	4.6
4531	10'	HD		
Cross Tee	Length	2'	4'	5'
4512	2'	55.0 [▲]		
4524	4'		13.2	
4514	4'		14.5	
4518	4'		14.5	
4521	5'			7.7
4515	5'			7.7
4519	5'			7.7
4516	6'			
4528	8'			

▣ To convert data into lb/ft², divide on center spacing of component into lb/ft.

▲ Weight limited by a safety factor of 2.

Ultraline™ 4550 $9/16$ " Exposed with $1/4$ " Reveal

ALLOWABLE LOAD per ASTM C635 ▣

Main Tee	Length	Hanger Spacing	
		2'	4'
4550	12'		H
D			
Cross Tee	Length	2'	4'
4562	2'	55.0 [▲]	
4564	4'		14.5
4568	4'		14.5

▣ To convert data into lb/ft², divide on center spacing of component into lb/ft.

▲ Limited by safety factor of 2.

Ultraline™ 4600 $9/16$ " Exposed with $1/8$ " Reveal

ALLOWABLE LOAD per ASTM C635 ▣

Main Tee	Length	Hanger Spacing		
		4'	5'	6'
4600	12'	ID	5.8	3.5
4640	12'	ID	8.4	4.6
4630	12'	HD	8.4	4.6
4601	10'	ID		
4602	10'	ID		
Cross Tee	Length	2'	4'	5'
4612	2'	55.0 [▲]		
4624	4'		13.2	
4614	4'		14.5	
4618	4'		14.5	
4621	5'			7.7
4615	5'			7.7
4616	6'			
4628	8'			

▣ To convert data into lb/ft², divide on center spacing of component into lb/ft.

▲ Weight limited by a safety factor of 2.

Non-Fire Rated Assemblies

Hanger Positions for Non-Fire Rated Situations
This illustrates hanger positions for single fixtures in a field.

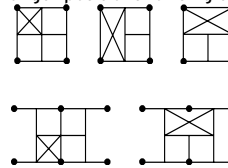

Provide extra hangers for tandem fixtures.

Fire Rated Assemblies

Hanger Positions for Fire Rated Situations

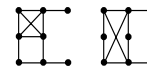

This illustrates hanger positions for single fixtures in a field and are covered in the table. Refer to specific design numbers for allowable number of fixtures per square footage of ceiling area.

Non-Fire Rated Assemblies

Hanger Positions for Non-Fire Rated Situations
This illustrates hanger positions for single fixtures in a field.

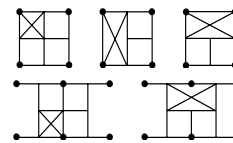

Provide extra hangers for tandem fixtures.

Component Performance Data

Light Fixture Load Test Data (based on 1/360 span deflection)

LIGHT FIXTURES	MAIN & CROSS TEES - ALLOWABLE FIXTURE WT. – LBS.							
	4500			4550		4600		
	4500	4500	4530	4550	4550	4600	4630	
Dimensions	4514	4524	4514	4564	4568	4614	4614	
2' x 2'	42.4		42.4	43.2	43.2	42.4	42.4	
2' x 4'	58.4	58.4	58.4	67.2	67.2	58.4	58.4	
20" x 48"								

Specification Data

suspension type		4500	4550	4600
material	body galvanized	•	•	•
	cap N/A			
size	width	9/16"	9/16"	9/16"
	height	1 5/8"	1 5/8"	1 5/8"
fire	fire rated ¹		•	
performance	heavy duty per ASTM C 635	•		•
	intermediate duty per ASTM C 635	•	•	•
	demountable	•		
seismic	zones / categories	3,4 / D, E, F	3,4 / D, E, F	3,4 / D, E, F
warranty	40 year limited	•	•	•
sustainability	Minimum 25% recycled content, 100% locally recyclable, global/regional manufacture	•	•	•

Palletization

Product Number	Cartons Per Pallet	Weight Per Pallet	LF Per Pallet
Main Tees			
4500.01	24	1,440	5,760
4550.01	24	1,896	5,760
4540.01	24	1,440	5,760
4530.01	24	1,752	5,760
4560.01	24	1,896	5,760
4503.01	24	1,224	4,800
4501.01	24	1,224	4,800
4502.01	24	1,224	4,800
4531.01	24	1,584	4,800
4600.01	24	1,416	5,760
4640.01	24	1,416	5,760
4630.01	24	1,944	5,760
4601.01	24	1,608	4,800
4602.01	24	1,608	4,800

8 Ft. Cross Tee

4528.01	PTO	PTO	PTO
4628.01	PTO	PTO	PTO

6 Ft. Cross Tee

4516.01	PTO	PTO	PTO
4616.01	PTO	PTO	PTO

5 Ft. Cross Tee

4521.01	30	1,560	6,000
4515.01	30	1,560	6,000
4519.01	30	1,560	6,000
4525.01	30	1,560	6,000
4621.01	PTO	PTO	PTO
4615.01	PTO	PTO	PTO

4 Ft. Cross Tees

4524.01	42	1,722	6,720
4514.01	42	1,722	6,720
4564.01	42	1,722	6,720
4518.01	42	1,722	6,720
4568.01	42	1,722	6,720
4624.01	42	1,722	6,720
4614.01	42	1,722	6,720
4618.01	42	1,722	6,720

Product Number	Cartons Per Pallet	Weight Per Pallet	LF Per Pallet
----------------	--------------------	-------------------	---------------

30 In. Cross Tees

4513.01	PTO	PTO	PTO
---------	-----	-----	-----

2 Ft. Cross Tees

4512.01	50	1,750	7,000
4562.01	50	1,750	7,000
4612.01	50	1,800	7,000

20 In. Cross Tees

4520.01	50	1,450	5,800
4620.01	PTO	PTO	PTO

1 Ft. Cross Tees

4511.01	50	1,000	4,000
4611.01	PTO	PTO	PTO

Product Number	Product Length	Cartons Per Pallet	Weight Per Pallet	LF Per Pallet
----------------	----------------	--------------------	-------------------	---------------

Wall Angles / Moldings Angles

1420.01	12	30	2,070	15,120
1480.01	12	30	1,170	9,000
21420.01	12	30	1,230	9,000
1467.01	12	30	1,170	9,000

Shadow Moldings

1460.01	10	32	2,048	12,800
1461.01	10	32	2,880	12,800
1466.01	12	20	1,220	4,800
1468.01	12	32	2,464	12,800
1469.01	10	Packaged To Order		

4500 Ultraline™

PART 1 - GENERAL

1.01 Section Includes

Provide metal suspension system for acoustical lay-in panel ceiling.

1.02 Related Sections

- A. Section 09 22 26 - Suspension Systems
- B. Section 09 54 00 - Specialty Ceilings
- C. Section 09 29 00 - Gypsum Board
- D. Section 09 58 00 - Integrated Ceiling Assemblies
- E. Section 13 48 00 - Sound, Vibration, and Seismic Control
- F. Section 23 50 00 - Central Heating Equipment
- G. Section 26 50 00 - Lighting

1.03 References

- A. American Society for Testing and Materials (ASTM)
 1. C635 - Standard Specification for the manufacture, performance, and testing of Metal Suspension Systems for Acoustical tile and Lay-in Panel Ceilings.
 2. C636 - Standard Practice for installation of Metal Ceiling Suspension Systems for Acoustical Tile and Lay-in Panels.

1.04 Submittals

- A. Product data sheets listing dimensions, load carrying capacity and standards compliance.
- B. 12 inch long samples of main tee and cross tee with end couplings.

1.05 Project Conditions

- A. Environmental Requirements:
 1. Verify weather tightness of area to receive suspension system prior to installation.
 2. Wet trades work shall be dry and complete prior to installation.
 3. Installation to begin only when temperature and humidity conditions closely approximate interior conditions which will exist when area is complete and occupied.
 4. Heating and air conditioning systems to be operating prior to, during, and after installation.

1.06 Maintenance

Furnish additional material equal to ____ percent of ceiling area.

PART 2 - PRODUCTS

2.01 Manufacturers

Chicago Metallic Ultraline 4500 (Heavy) (Intermediate) duty suspension system.

2.02 Suspension System Components

- A. Main Tees:
 1. Manufactured from commercial quality galvanized steel $\frac{9}{16}$ inch wide with $\frac{1}{4}$ inch center regress by $1\frac{5}{8}$ inches high by (120) (144) inches long with factory punched cross tee slots, hanger holes, miters and integral couplings.
 2. Coated with factory applied color baked-on enamel finish.
- B. Cross Tees:
 1. Manufactured from commercial quality galvanized steel $\frac{9}{16}$ inch wide with $\frac{1}{4}$ inch center regress by $1\frac{5}{8}$ inches high by (24) (48) (60) inches long with factory punched cross tee slots, hanger holes, miters and integral couplings.
 2. Finish and regress identical to main tees.
- C. Angle Moldings: Manufactured from commercial quality galvanized steel $\frac{9}{16}$ inch wide by $1\frac{5}{16}$ inch high by 144 inches long with hemmed edges, finished identical to main tees and cross tees.
- D. Shadow Moldings: Manufactured from commercial quality galvanized steel with $\frac{3}{4}$ inch flanges and $\frac{9}{8}$ inch steps coated with factory applied baked-on enamel paint finish identical to main tees and cross tees.

PART 3 - EXECUTION

3.01 Examination

Examine area receiving suspension system to identify conditions which will adversely affect installation. Do not begin installation until adverse conditions have been remedied.

3.02 Installation

- A. Main Tees: Installed (48) (60) inches on center, by direct suspension from existing structure, with not less than 12 gage hanger wires, wrapped tightly 3 full turns, spaced 48 inches on center along component length.
- B. Cross Tees:
 1. Installed perpendicular to main tees (24) (48) (60) inches on center to form _____ by _____ modules.
 2. Installed perpendicular to module forming cross tees 24 inches on center forming _____ by _____ modules.
 3. Installed adjacent to each unsupported side of recessed fixtures.
- C. (Angle) (Shadow) moldings: Installed on vertical surfaces, intersecting main tees and cross tees, by appropriate method in accordance with industry accepted practice.

3.03 Repair

- A. Remove damaged components, replace with undamaged components. Clean with non-solvent based non-abrasive commercial cleaning solution.

4550 Ultraline™

PART 1 - GENERAL

1.01 Section Includes

Provide metal suspension system for acoustical lay-in panel ceiling.

1.02 Related Sections

- A. Section 09 22 26 - Suspension Systems
- B. Section 09 54 00 - Specialty Ceilings
- C. Section 09 29 00 - Gypsum Board
- D. Section 09 58 00 - Integrated Ceiling Assemblies
- E. Section 13 48 00 - Sound, Vibration, and Seismic Control
- F. Section 23 50 00 - Central Heating Equipment
- G. Section 26 50 00 - Lighting

1.03 References

- A. American Society for Testing and Materials (ASTM)
 1. C635 - Standard Specification for the manufacture, performance, and testing of Metal Suspension Systems for Acoustical tile and Lay-in Panel Ceilings.
 2. C636 - Standard Practice for installation of Metal Ceiling Suspension Systems for Acoustical Tile and Lay-in Panels.

B. Underwriters Laboratories (UL) Fire Resistance Directory (Latest Edition)

1.04 Submittals

- A. Product data sheets listing dimensions, load carrying capacity and standards compliance.
- B. 12 inch long samples of main tee and cross tee with end couplings.

1.05 Project Conditions

- A. Environmental Requirements:
 1. Verify weather tightness of area to receive suspension system prior to installation.
 2. Wet trades work shall be dry and complete prior to installation.
 3. Installation to begin only when temperature and humidity conditions closely approximate interior conditions which will exist when area is complete and occupied.
 4. Heating and air conditioning systems to be operating prior to, during, and after installation.

1.06 Maintenance

Furnish additional material equal to ____ percent of ceiling area.

PART 2 - PRODUCTS

2.01 Manufacturers

Chicago Metallic Ultraline 4550 (Heavy) (Intermediate) duty suspension system.

2.02 Suspension System Components

- A. Main Tees:
 1. Manufactured from commercial quality galvanized steel $\frac{9}{16}$ inch wide with $\frac{1}{4}$ inch center regress by $1\frac{5}{8}$ inches high by 144 inches long with factory punched cross tee slots, hanger holes, miters, and integral couplings.
 2. Coated with factory applied color baked-on enamel finish with a _____ color regress.
- B. Cross Tees:
 1. Manufactured from commercial quality galvanized steel $\frac{9}{16}$ inch wide with $\frac{1}{4}$ inch center regress by $1\frac{5}{8}$ inches high by (24) (48) inches long with factory punched cross tee slots, hanger holes, miters and integral couplings.
 2. Finish and regress identical to main tees.
- C. Angle Moldings: Manufactured from commercial quality galvanized steel ($\frac{9}{16}$) inch wide by $1\frac{5}{16}$ inch high by 144 inches long with hemmed edges, finished identical to main tees and cross tees.
- D. Shadow Moldings: Manufactured from commercial quality galvanized steel with $\frac{3}{4}$ inch flanges and $\frac{9}{8}$ inch steps coated with factory applied baked-on enamel paint finish identical to main tees and cross tees.

PART 3 - EXECUTION

3.01 Examination

Examine area receiving suspension system to identify conditions which will adversely affect installation. Do not begin installation until adverse conditions have been remedied.

3.02 Installation

- A. Suspension System Components: Installed in accordance with UL design number _____ guidelines.
- B. Main Tees: Installed (48) (60) inches on center, by direct suspension from existing structure, with not less than 12 gage hanger wires, wrapped tightly 3 full turns, spaced 48 inches on center along component length.
- C. Cross Tees:
 1. Installed perpendicular to main tees (24) (48) (60) inches on center to form _____ by _____ modules.
 2. Installed perpendicular to module forming cross tees 24 inches on center forming _____ by _____ modules.
 3. Installed adjacent to each unsupported side of recessed fixtures.
- D. (Angle) (Shadow) moldings: Installed on vertical surfaces, intersecting main tees and cross tees, by appropriate method in accordance with industry accepted practice.

3.03 Repair

- A. Remove damaged components, replace with undamaged components. Clean with non-solvent based non-abrasive commercial cleaning solution.

4600 Ultraline™

PART 1 - GENERAL

1.01 Section Includes

Provide metal suspension system for acoustical lay-in panel ceiling.

1.02 Related Sections

- A. Section 09 22 26 - Suspension Systems
- B. Section 09 54 00 - Specialty Ceilings
- C. Section 09 29 00 - Gypsum Board
- D. Section 09 58 00 - Integrated Ceiling Assemblies
- E. Section 13 48 00 - Sound, Vibration, and Seismic Control
- F. Section 23 50 00 - Central Heating Equipment
- G. Section 26 50 00 - Lighting

1.03 References

- A. American Society for Testing and Materials (ASTM)
 - 1. C635 - Standard Specification for the manufacture, performance, and testing of Metal Suspension Systems for Acoustical tile and Lay-in Panel Ceilings.
 - 2. C636 - Standard Practice for installation of Metal Ceiling Suspension Systems for Acoustical Tile and Lay-in Panels.

1.04 Submittals

- A. Product data sheets listing dimensions, load carrying capacity and standards compliance.
- B. 12 inch long samples of main tee and cross tee with end couplings.

1.05 Project Conditions

- A. Environmental Requirements:
 - 1. Verify weather tightness of area to receive suspension system prior to installation.
 - 2. Wet trades work shall be dry and complete prior to installation.
 - 3. Installation to begin only when temperature and humidity conditions closely approximate interior conditions which will exist when area is complete and occupied.
 - 4. Heating and air conditioning systems to be operating prior to, during, and after installation.

1.06 Maintenance

Furnish additional material equal to _____ percent of ceiling area.

PART 2 - PRODUCTS

2.01 Manufacturers

Chicago Metallic Ultraline 4600 (Heavy) (Intermediate) duty suspension system.

2.02 Suspension System Components

- A. Main Tees:
 - 1. Manufactured from commercial quality galvanized steel $\frac{9}{16}$ inch wide with $\frac{1}{8}$ inch center regress by $1\frac{1}{8}$ inches high with factory punched cross tee slots, hanger holes, miters and integral couplings.
 - 2. Coated with factory applied baked-on enamel finish.
- B. Cross Tees:
 - 1. Manufactured from commercial quality galvanized steel $\frac{9}{16}$ inch wide with $\frac{1}{8}$ inch center regress by $1\frac{1}{8}$ inches high with factory punched cross tee slots, hanger holes, miters and integral couplings.
 - 2. Finish and regress identical to main tees.
- C. Angle Moldings: Manufactured from commercial quality galvanized steel $\frac{9}{16}$ inch wide by $1\frac{5}{16}$ inch high by 144 inches long with hemmed edges, finished identical to main tees and cross tees.
- D. Shadow Moldings: Manufactured from commercial quality galvanized steel with $\frac{3}{4}$ inch flanges and $\frac{3}{8}$ inch steps coated with factory applied baked-on enamel paint finish identical to main tees and cross tees.

PART 3 - EXECUTION









3.01 Examination

Examine area receiving suspension system to identify conditions which will adversely affect installation. Do not begin installation until adverse conditions have been remedied.

3.02 Installation

- A. Main Tees: Installed (20), (30), (48), (60) inches on center, by direct suspension from existing structure, with not less than 12 gage hanger wires, wrapped tightly 3 full turns, spaced 48 inches on center along component length.
- B. Cross Tees:
 - 1. Installed perpendicular to main tees (20), (24), (30), (48), (60) inches on center to form _____ by _____ modules.
 - 2. Installed perpendicular to the module forming cross tees (20), (24), (30) inches on center forming _____ by _____ modules.
 - 3. Installed adjacent to each unsupported side of recessed fixtures.
- C. (Angle), (Shadow Line) Moldings: Installed on vertical surfaces, intersecting main runners and cross tees, by appropriate method in accordance with industry accepted practice.

Product Cross Reference Guide

Chicago Metallic	AWI	USG
General Application Grid		
200 Snap-Grid™	Prelude ML™	–
 250 Fire-Front Snap-Grid™	–	–
1200 Seismic	Prelude XL™	DX
 1250 Fire-Front Seismic	Prelude XL™ Fire Guard	DXL Fire Rated™
4000 Temptra™	Suprafine XL™	DXT Centricitee™
 4050 Temptra™ Fire Rated	Suprafine XL™ Fire Guard	DXLT Centricitee™
4500 Ultraline™	Silhouette™ XL 1/4" Reveal	DXF Finline® 1/4"
 4550 Ultraline™ Fire Rated	Silhouette™ XL Fire Guard 1/4"	DXF Finline® 1/4"
4600 Ultraline™	Silhouette™ XL 1/8" Reveal	DXF Finline® 1/8"
Special Application Grid		
Ultraline 4500 HRCmax™	Silhouette™ XL HRC	DXF HRC Finline® 1/4"
Ultraline 4600 HRCmax™	Silhouette™ XL HRC	DXF HRC Finline® 1/8"
4000 Temptra™ HRCmax™	Suprafine XL™ HRC	DXT HRC Centricitee™
1200 HRCmax™ (Stab)	Prelude XL™ HRC	DX HRC
BarrierGrid™ Standard	Clean Room	Controlled Environment
BarrierGrid™ Premium	Clean Room	Controlled Environment
 260/280 Aluminum Cap	–	–
 1260/1280 Aluminum Cap	Prelude XL™	DXLA Aluminum Cap™
660 1 ³ / ₈ " Wide Face	–	DXW
730 Stainless	SS Prelude Plus XL™	DXSS
830 Aluminum	AL Prelude Plus XL™	AX All Aluminum™
 1830 HDG-60	Prelude XL™ Exterior	ZXLA™ Hot Dipped
Drywall Grid		
640/660	Drywall Grid	–
 650/670 Fire Rated	Drywall Grid Fire Guard	Drywall Suspension
Span Fast ®	ShortSpan™	Wall-to-Wall™

Service

Service Levels

Service Levels represents the approximate time in weeks for an order to be ready to ship from the manufacturing plant. Add 2 weeks to all Service Levels for CMC transfer truck to Baltimore or Los Angeles Service Centers.

Service Level begins when the following criteria are met – Receipt of acceptable Purchase Order, Credit Approval, Drawing Approval, Color Approval.

Service Levels	Production Lead Time
0	Stock item available for immediate shipment
1	Available to ship within 1 week of order acceptance
2	Available to ship within 2 weeks of order acceptance
3	Available to ship within 3 weeks of order acceptance
4	Available to ship within 4 weeks of order acceptance
5	Available to ship within 5 weeks of order acceptance
6	Available to ship within 6 weeks of order acceptance
??	Contact Chicago Metallic for current lead time

Color Samples

1. Custom color matching requires customer color sample or paint manufacturer and color number.
2. CMC will provide color sample for approval upon request.
3. Service Level begins after receipt of color approval.

Order Placement and General Customer Service Support

Phone: 1.800.323.7164 / option 1
 Fax: 1.866.211.3824
 Email: cmc-customerservice@chicagometallic.com

Standard Samples and Literature

Standard literature, product samples and color samples are available from the CMC Sample and Literature department at no charge.

Phone: 1.800.323.7164/ option 1
 Fax: 1.800.222.3744
 Email: cmc-customerservice@chicagometallic.com

Technical Support

Requests for technical information on CMC Metal Ceilings may be placed with the Technical Services Department.

Phone: 1.800.323.7164 option 3
 Fax: 1.888.329.2620
 Email: techservices@chicagometallic.com

Mockups and Custom Samples

When CMC has agreed to provide custom samples or mockups, the cost for them will be billed to the account.

CMC will be glad to issue credit upon request for all mockups and custom sample invoices when valid orders for these products are placed with our Customer Service Department.

Phone: 1.888.991.7070
 Fax: 1.866.211.3824
 Email: cmc-customerservice@chicagometallic.com

General Conditions of Sale

Order Acceptance

Whenever used herein, "Seller" shall refer to Chicago Metallic Corporation and "Purchaser" shall refer to the party ordering or purchasing products ("Products") from Seller. Seller's price list does not constitute an offer to sell Products listed therein, but is simply provided as a convenience to prospective Purchasers. Purchaser's order to Seller shall constitute an offer to Seller to purchase Products which offer Seller may accept at its sole discretion. Acceptance shall be by a writing containing these General Conditions of Sale ("Conditions"). Acceptance of Purchaser's order or any part of it by Seller is expressly made conditional on Purchaser's assent to these Conditions. Purchaser may vary these Conditions only with the written consent of Seller. Acceptance of Products by Purchaser or failure of Purchaser to object in writing to these Conditions within ten (10) days following delivery of Products to Purchaser shall constitute Purchaser's assent to these Conditions.

Shipment and Delivery

Seller shall deliver Product F.O.B. place of shipment. Risk of loss to Product shall pass to Purchaser upon delivery to carrier at such place of shipment. Carrier acts as Purchaser's agent. Products shall be shipped as soon as practical, or as requested by Purchaser after order acceptance by Seller. However, delivery dates shall not be of the essence, but shall be regarded as Seller's best approximation of such delivery dates. Seller may arrange freight at the request of and on behalf of Purchaser. If applicable, freight will be charged according to the Seller's freight policy in effect at time of shipment. Such policy will be provided to Purchaser via its preferred communication method and is also available in Seller's price book or upon request. All taxes, tariffs, duties or similar charges paid by Seller imposed or levied by any governmental authority in connection with the purchase, shipment, import or export of Products purchased or in connection with the procuring of materials used therein may at Seller's sole option be added to the price of Products so affected. Additional shipping charges for Products paid by Seller such as destination, storage, labor and redelivery and special or extra expenses for handling air freight, bus or other shipments may also, at Seller's sole option, be added to the price of such Products.

Payment

Payment for all Products shall be net cash due and payable in U.S. dollars within thirty (30) days following receipt by Purchaser of shipping documents for such Products by check or bank transfer to a bank account to be designated by Seller. If accounts are paid within ten (10) days following receipt by Purchaser of the corresponding shipping documents, Purchaser shall be entitled to a one percent (1%) discount from the price of Products only. If, in Seller's sole opinion, the financial condition of the Purchaser so warrants, Seller may require advance payments or satisfactory security. In the event that the Purchaser fails to make such advance payments or furnish such security upon Seller's request, delivery of Products may be suspended without further Seller obligation. Seller may, at Seller's sole option, require payment by means of an irrevocable letter of credit opened and confirmed by a bank or banks acceptable to Seller and upon terms and conditions acceptable to Seller.

Limited Warranty

Seller warrants to Purchaser that Products will substantially conform in quantity and quality to Purchaser's order, as accepted by Seller, provided, however, that (1) Products are inspected by Purchaser upon arrival at place of destination and any and all nonconformities are noted on the bill of lading and all other delivery documents and are attested to in writing by carrier's representative (2) Purchaser furnishes Seller with written notice of such non-conformities within fifteen (15) days following arrival of non-conforming Products at the place of destination, (3) Purchaser holds nonconforming Products for Seller's inspection (4) non-conformities occurred prior to delivery by Seller of Products F.O.B. place of shipment, and (5) Purchaser does not alter, repair, use or attempt to alter or repair any non-conforming Products. This limited warranty is Seller's only and exclusive express warranty to Purchaser. Seller disclaims any and all implied warranties including without limitation any implied warranty of merchantability or fitness for a particular purpose. Purchaser's sole and

exclusive remedy against Seller shall be the replacement F.O.B. its plant or site, at Seller's option, of any Products which do not conform to Seller's limited warranty hereunder. No other remedy (including, without limitation, incidental or consequential damages for lost profits, lost sales, injury to persons or property or any other incidental or consequential loss) shall be available to Purchaser. Purchaser agrees to include in all contracts between Purchaser and subsequent owners or users of Products, and to bring to the attention of all Purchaser's customers of Products, the following warranty disclaimer: Chicago Metallic Corporation disclaims any and all warranties expressed or implied, including, without limitation, any implied warranty of merchantability or fitness for a particular purpose. Purchaser shall be excluded on behalf of Seller all remedies for damage or injury to Products persons or property. In the event that Purchaser fails to comply with the foregoing obligations, Purchaser shall indemnify Seller for any liability resulting from such non-compliance and shall otherwise hold Seller harmless.

Returns

In order to return any Products to Seller, Purchaser must first obtain prior authorization for products eligible for return, and receive a Return Goods Authorization number from Seller's home office. All authorized returns are subject to a 20% restocking charge. Seller will only issue credit for Service Level "0" material received at the designated company facility with the Return Goods Authorization appearing on the material, and after being inspected and determined by Seller to be in resalable condition. Purchaser is solely responsible for arranging and prepaying for all return freight. Seller will not be responsible for any damage in transit on material returned at customer's request, and will not file freight claims on such damaged material. When these terms are met, seller will issue appropriate material credit less the restocking charge.

Default, Termination and Suspension of Delivery

Seller reserves the right, among other remedies, either to cancel Purchaser's order or suspend further deliveries of Products thereunder in the event that (1) Purchaser fails to pay for any one shipment of Products when payment for such shipment becomes due; (2) Purchaser fails to make any advance payments or satisfactory security demanded by Seller pursuant to paragraph two of PAYMENTS section above; or (3) Purchaser fails or refuses to accept any delivery of Products ordered from Seller. Delivery of Products may be suspended in whole or in part in case of any event beyond Seller's control, including, but not limited to, explosion, fire, shortage of fuel, power or raw materials flood strike lockout, injunction, riot, insurrection, war, national emergency, government act, or act of God.

Miscellaneous

No failure or delay on the part of Seller in exercising any right, power or privilege hereunder shall operate as a waiver thereof or of any other right, power or privilege hereunder nor shall any single or partial exercise of any such right power or privilege preclude any other right, power or privilege. The rights or remedies of Seller hereunder are cumulative and not exclusive of any rights or remedies which it may otherwise have. The parties hereto may correct stenographic and clerical errors without liability. Purchaser may not assign the order without the express written consent of Seller. All notices to be given hereunder by either party to the other party shall be dispatched by certified or registered mail return receipt requested addressed to the last known post office address of such other party. Any such notice shall be deemed received within five (5) days following any such dispatch if mailed from within the United States of America and ten (10) days if mailed from outside the United States of America. Either party may change its address by notice to the other party. These Conditions shall be governed by and interpreted in accordance with the laws of the State of Illinois, United States of America, and all disputes hereunder that cannot be amicably resolved by the parties thereto must be settled in a court of competent jurisdiction within the State of Illinois, United States of America. The provisions of these Conditions shall be severable one from the other so that should any provision be held legally unenforceable by a court of competent jurisdiction, the remaining provisions shall remain in effect.

Chicago Metallic Ceiling Products



Metal

Perimeter Trim / Curvilinear / Flat Metal Panel / Embossed Metal Panel / Linear / Open Plenum / Security



Panel

Premium / Utility / Controlled Environment



Grid

General Applications / Special Applications / Drywall Applications

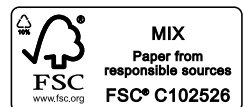

Ceiling Systems and Specialty Products - USA and Canada: 800.323.7164 / Fax: 800.222.3744 / chicagometallic.com

BELGIUM / DENMARK / UK / GERMANY / FRANCE / HONG KONG / PRC / MALAYSIA / UNITED ARAB EMIRATES / MEXICO

Chicago Metallic, its logo, Fast.Easy.Customer Focused., SpanFast and QuickClick are Registered Trademarks of Chicago Metallic Corporation. Snap-Grid, Tempra and Ultraline are trademarks of Chicago Metallic Corporation.
© 2011 Chicago Metallic Corporation All Rights Reserved Printed in USA SNL0028G0511

Literature Disclaimer: Presentations in this brochure or any other Chicago Metallic Corporation publication are correct to the best of our knowledge at time of preparation. We provide this information in an advisory capacity only. Any advisory recommendations given in our publications **must be modified to conform with local codes, conditions and specifications.** We reserve all rights to amend any information published in our literature without additional notice. **Chicago Metallic can not be held responsible or liable for the selection nor application of our products.**