

CATSKILL

C R A F T S M E N , I N C .

Assembly Instructions Model 54230

Butcher Block WorkCenter PLUS



GENERAL:

1. You have purchased model 54230.
2. Should you need assistance or need to replace a damaged or missing part simply give us a call M-F at 607-652-7321 from 7:30 am - 4:30 pm EST and we'll send you the prepaid part via UPS usually that same day! You may also email us info@catskillcraftsmen.com.
3. Read the assembly instructions and the enclosed brochure before beginning assembly. Assembly is easy if you read and follow the instructions step by step. See our website for assembly tips and videos.
4. Tools required: Phillips screwdrivers, medium and small; medium flat blade screwdriver and a hammer.
5. Drawer glides are sometimes pre-packed with screws, these are not used.
6. Directions (left/right, front/back) are given as facing the front of an assembled upright unit.

Parts List Model 54230



Center Shelf (1)
P/N CS-54230



Small Middle Shelf (2)
P/N SMS-54230

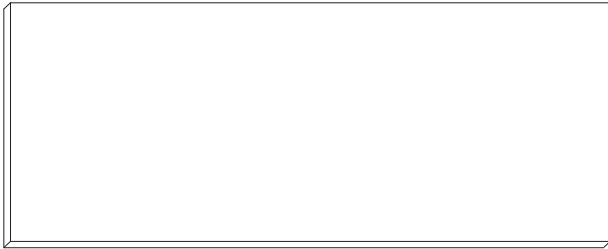

Bottom Shelf (1)
P/N BS-54230

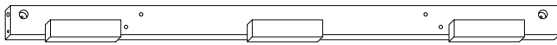

Top Front Brace (1)
P/N B-38/2 7/16/BOT-54230



Bottom Front Brace (1)
P/N B-38/2 7/16/TF-54230

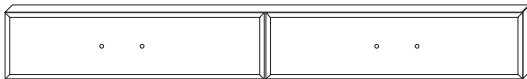

Drawer Front (1)
P/N DF-54230



Drawer Back (1)
P/N DBK-54230



Right Drawer Side (1)
P/N DS-54230R



Left Drawer Side (1)
P/N DS-54230L

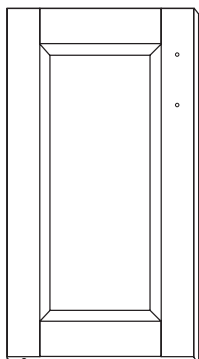

Left Door (1)
P/N DOR-54230LO

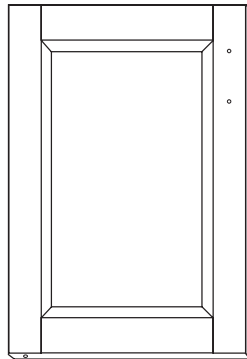

Left Center Door (1)
P/N DOR-54230LC

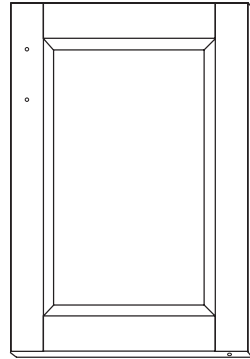

Right Center Door (1)
P/N DOR-54230RC

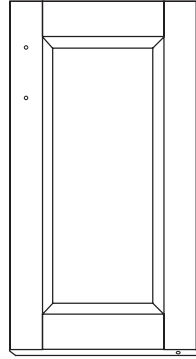

Right Door (1)
P/N DOR-54230RO

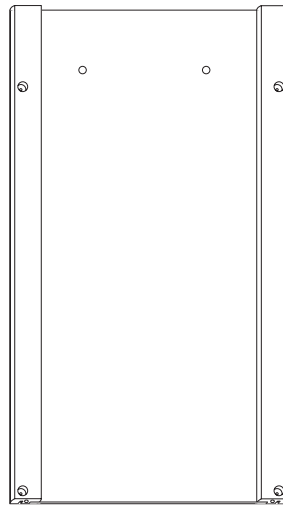

Side Panel (2)
P/N SP/HDL-54230

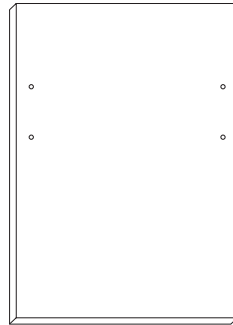

Divider Panel (2)
P/N DP-54230

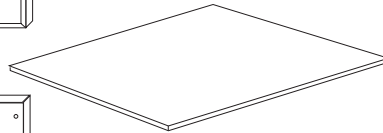

Drawer Bottom (1)
P/N DBOT-54230

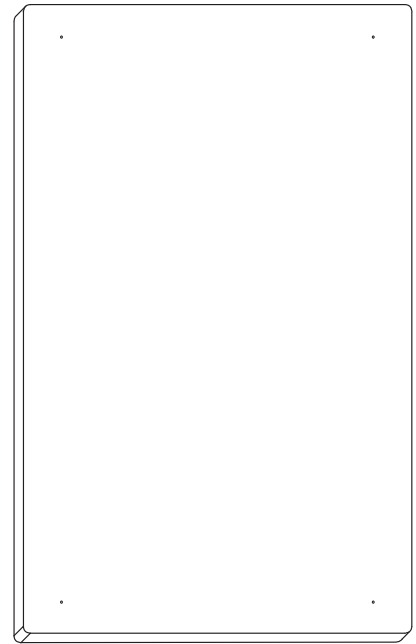
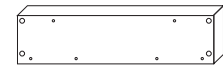
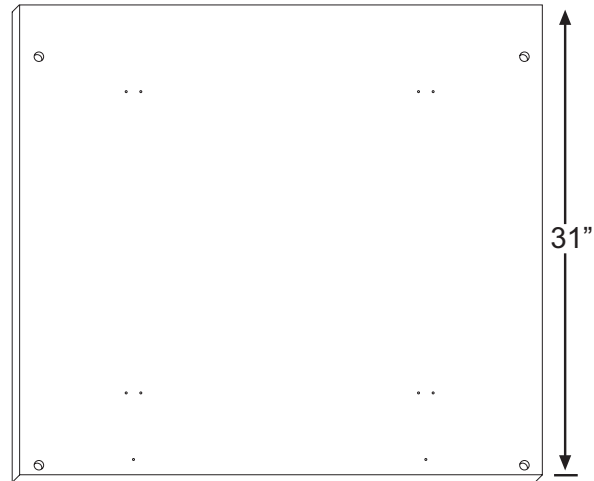

Table Top (1)
P/N TT-54230



Glide Support Stick (2)
P/N GLDSUP-54230



Back Panel (1)
P/N BP-54230

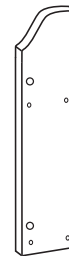

Spice Rack Side Left (1)
P/N SR-54230L

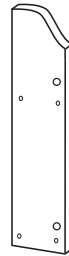

Spice Rack Side Right (1)
P/N SR-54230R



Spice Rack Shelves (2)
P/N SRS-54230

Hardware for 54230



1 3/4" Phillips Flat Head Bolt (8)



(8 are bronze for spice rack)

1 1/4" Phillips Flat Head #8 Screw (20)

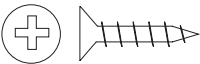

(8 used on "L" brackets and 4 used for cabinet glides)

5/8" Phillips Flat Head #7 Screw (12)



(Used on Drawer Glides)

5/8" Phillips Flat Head #5 Screw (4)

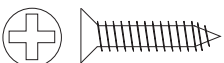

(Used to attach towel bar and spice rack)

1" Phillips Flat Head #8 Screw (4)



(Used to attach door handles)

7/8" Truss Head Machine Screw (8)



(Used to attach drawer handles)

1" Truss Head Machine Screw (4)



(divider panel pin for shelves)

2" Long 3/16" DIA. Steel Pin (8)



(door pin)

1 1/2" Long 3/16" DIA. Steel Pin (8)



(shelf pin)

1" Long 3/16" DIA. Steel Pin (22)



(brace pin)

3/4" Long 3/16" DIA. Steel Pin (4)

Magnet Pack



Magnet (4)

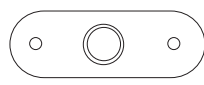

Magnet Plate (4)

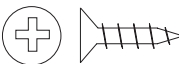

(Used on Magnet Plate)

1/2" Phillips Flat Head #4 Screw (4)

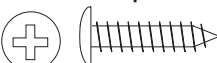

(Used on Magnet)

5/8" Pan Head Screw (8)

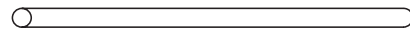

Retainer Rods for Spice Rack (2)



10-24 Hex Nut (8)



3/16" Flat Washer (8)



5/8 Wooden Disk (8)



Bastion Set Screw (2)

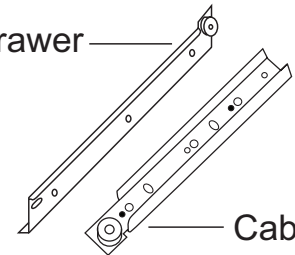

Drawer

Cabinet

Drawer Glide (1 Set)



Bastion Post (2)

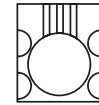

Bastion Barrel Nut (2)



Polished Nickel Towel Bar (1)

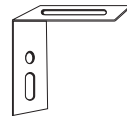

"L" Bracket (4)



Nickel Handle (6)



Towel Bar Post (2)



Metal Shelf Pin (4)

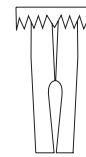

Caster Socket (4)

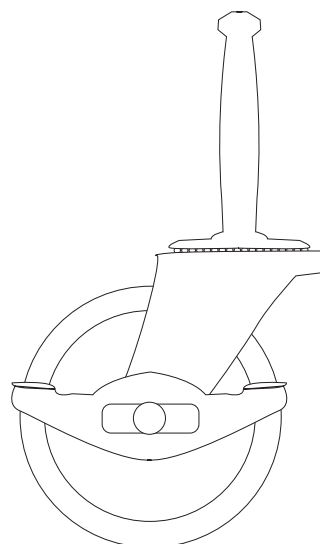

Locking Wheel Casters (2)

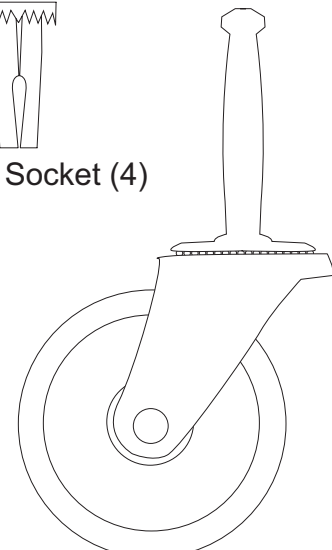

Wheel Casters (2)

STEP 1

A. Tap/insert ONE 1 1/2" pin into each end of all the doors. DON'T OVERDRIVE PINS! Pins should stick up about 1/2" when seated.

B. Attach the magnet plate (may be stuck to magnet!) with the 1/2" #4 screw to the top of the doors. Bumps go toward the wood.

C. Attach door handles with 7/8" truss head machine screws.

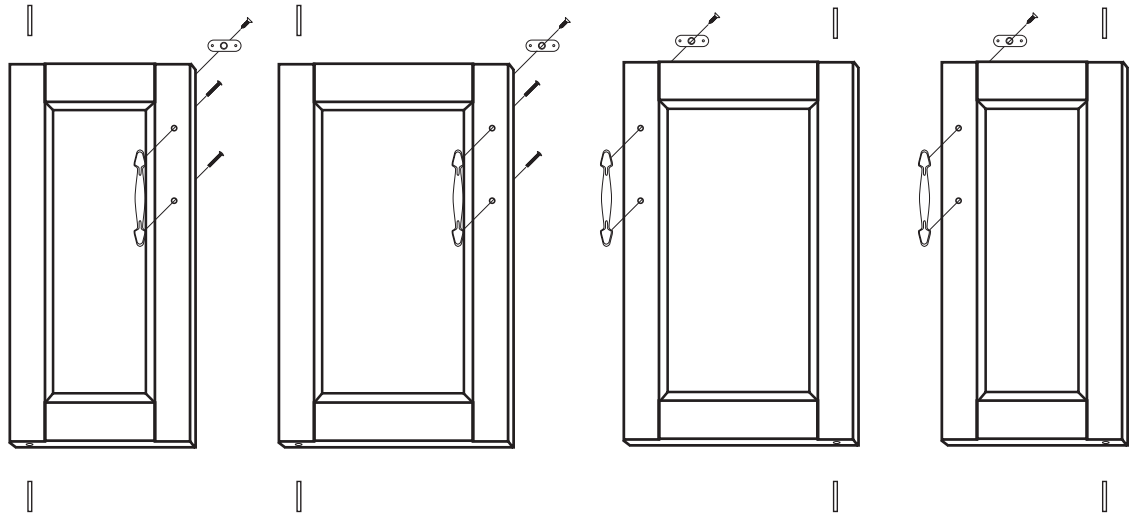

STEP 2

Take the 2 front braces and tap/insert one 3/4" steel pin into each end of both braces until seated. About 3/8" will stick out when seated. Ok if loose.

 4 used in this step
3/4" Long 3/16" DIA. Steel Pin

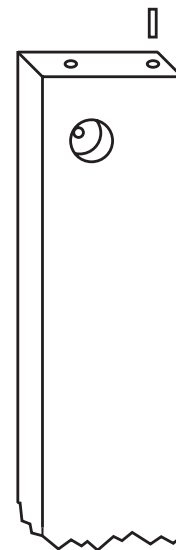

STEP 3

Assembly Spice Rack

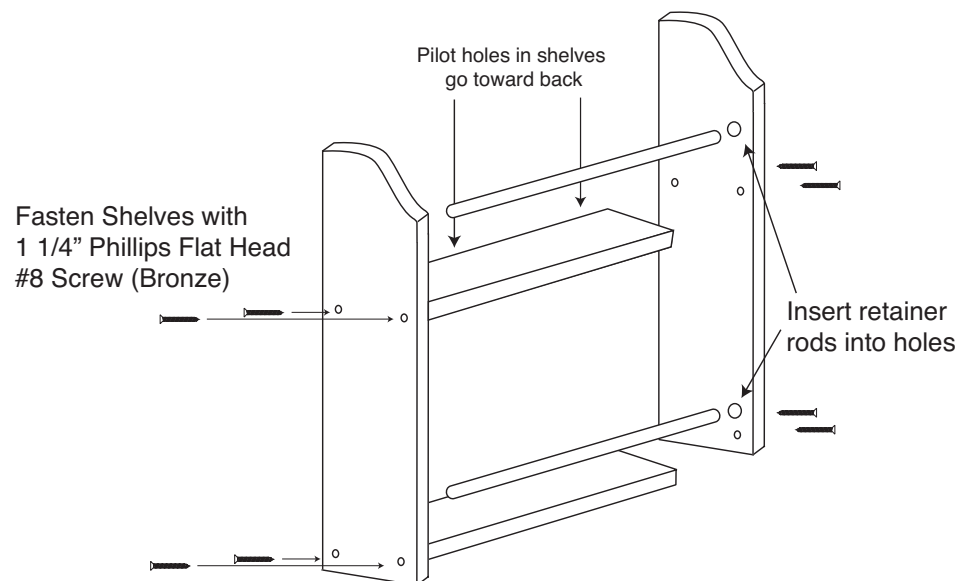

STEP 4

A. Attach the Drawer Back to the Drawer Sides with four 1 1/4" #8 screws. There are left and right sides. Make sure the slots that run the length of the Sides are aligned with the slot in the Drawer Back to accept the Drawer Bottom.

B. Slide in Drawer Bottom, best side up, to inside of drawer.

C. Take the 2 bastion posts, align the threaded end of the posts with the post holes located near the ends of the inside of the Drawer Front. Tighten posts down until the solid shaft of the posts hits the wood. Back post out until the hole/screwdriver slot in end of post is parallel and in direct line with the long edges of the Drawer Front.

D. Insert the barrel nuts into the nut access holes on the inside of the Drawer Sides with the threaded ends of the nuts facing out. Take the Drawer Front and carefully insert the posts into the ends of the Drawer Sides, through the sides of the nuts until seated. Push nut snug up against the wood in the nut access hole toward the inside of Drawer Front. Hole should be slightly off-center toward the Drawer Front. Insert the set screw and tighten down. The ends of the sides should be tight against the inside Drawer Front.

E. Attach the drawer handles with 1" Truss head machine screws.

F. Attach the drawer glides (left and right) to the Drawer Sides using two 5/8" #5 screws per side. Wheels go toward Drawer Back and are up. The end with no wheels should touch the Drawer Front.

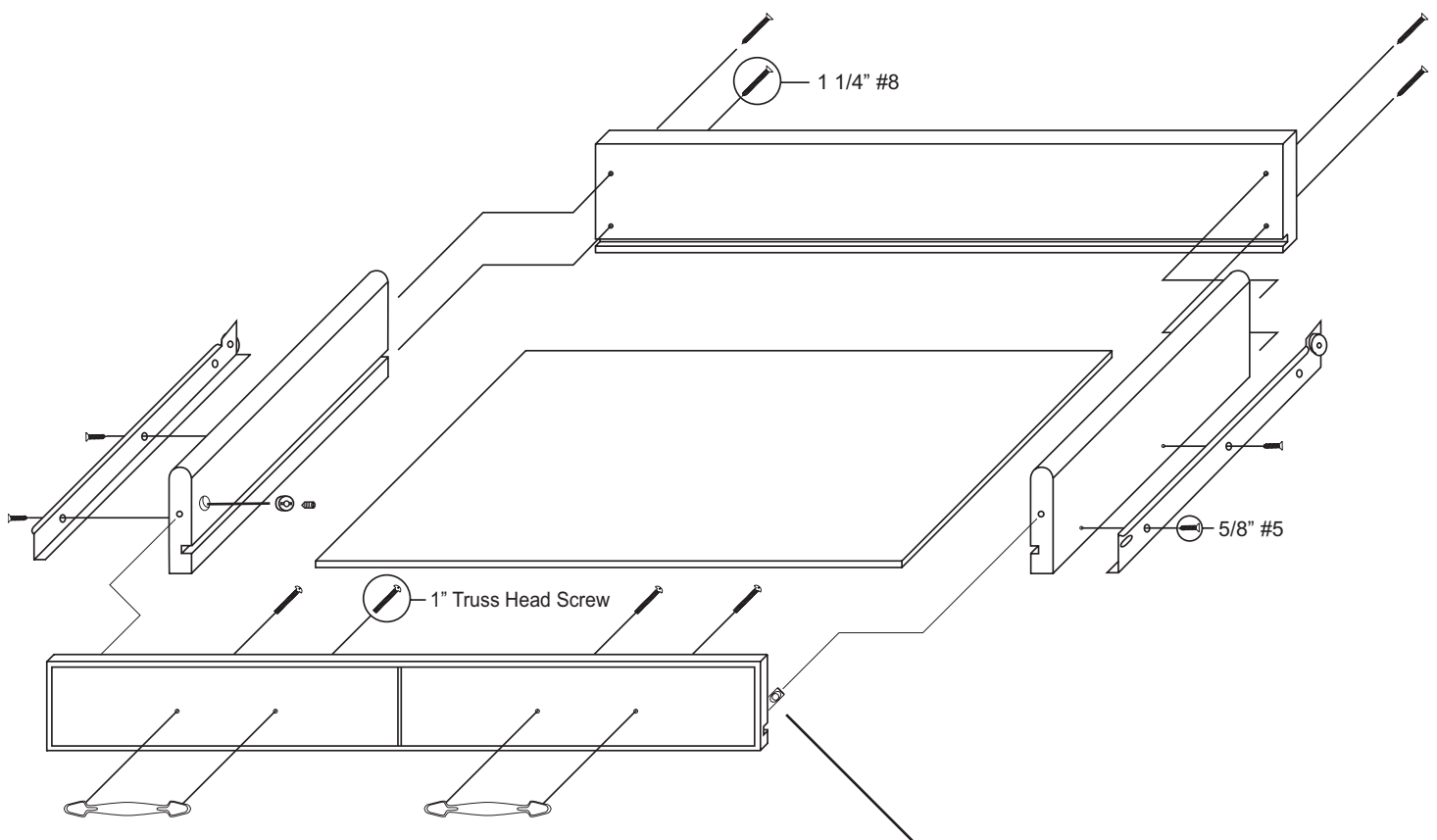

See next page to learn how the bastion fastening system works.

TIPS ON HOW THE BASTION FASTENING SYSTEM WORKS

1. The Bastion fastening system consists of a steel post (threaded on one end with a hole through the shaft on the other end); a Barrel Nut (cylindrical barrel-shaped with threaded open end & holes through the sides); and a Set Screw (Phillips slot on one end, pointed on the other)

2. To attach Posts: A) Dip threads of Post in vegetable oil. B) Align threaded end of Post with hole in wood, tap on slotted end with hard hammer until threads enter, then tighten down using a flat head screw driver or the provided allen wrench (See the Illus. Bas. 3 for alternate seating methods). **DO NOT TRY TO HAMMER THE POST ALL THE WAY IN AS IT WILL STRIP THE POST HOLE.** C) When solid shaft of Post hits wood, back out approximately ½ turn until the hole in the posts is properly aligned as per step by step directions. For example: the holes in the posts on the inside of the drawer front will be parallel with the long length of the drawer front when properly seated.

3. A) Place a Barrel Nut into the nut access hole, so that the threads in the nut face out. The small notches on either side of the nut opening, indicate the location of the holes through the sides of the nut. B) Insert the posts through the end of the braces (or drawer sides); through the holes in the sides of the nut. When properly aligned, you will see the hole in the post inside the barrel nut. Post hole should be slightly off-center toward the wood.

4. Insert the Set Screw into the threaded end of the nut and tighten down. The tip of the Set Screw will seek the center of the hole in the Post as it is tightened down, forcing the Nut toward the main shaft of the Post. This is what tightens the wooden parts together. Set screws should thread easily – **DON'T CROSS THREAD!** If Set Screw doesn't thread easily, check position of the hole in Post.

5. If the wooden parts are not tight against each other, the Post needs to be screwed a half turn at a time until wood joints are tight.

Illustration Bas. 1

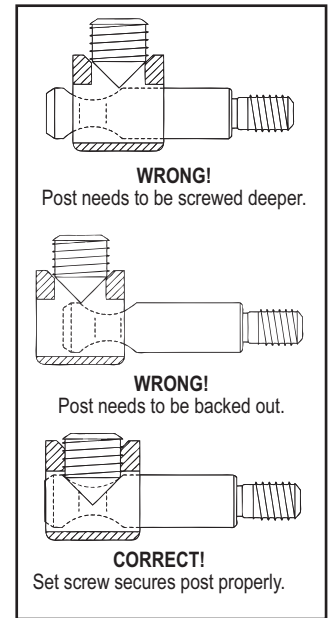

Step 1

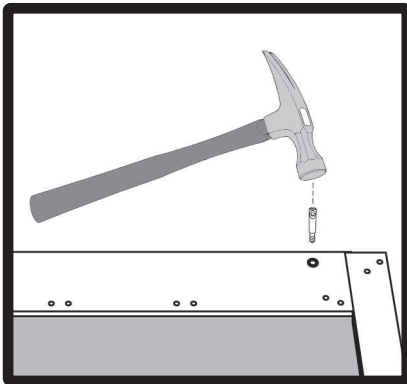
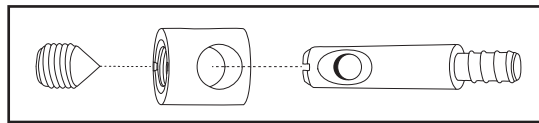
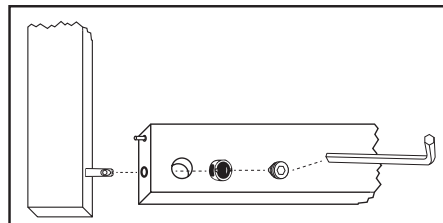

Illustration Bas. 2



Step 2



Allen Wrench Provided

Illustration Bas. 3

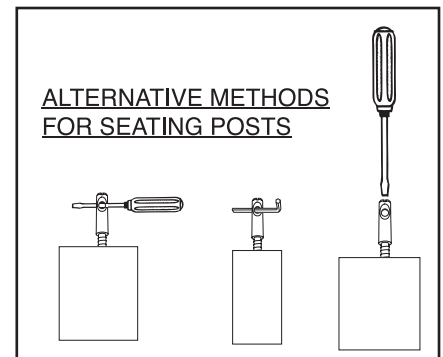

See video on our website!

If you have any questions regarding assembly or missing or damage parts, call our customer support number:

607-652-7321 or 888-732-7321.

STEP 5

A. Attach a Glide Support Stick to the top of each Side Panel using 1 1/4" #8 screws. The countersunk holes (reamed out) in the stick are positioned as in illustration so that the glide holes are toward the lower edge. Sticks should be flush with top of panel.

B. Attach the cabinet glide of the Drawer Glides to the Glide Support Stick using 5/8" #7 flat head screws. Left glide to left Side Panel, right glide to right Side Panel. The glides look almost alike however, the right glide (as you face the cart) has a rolled lip at the top of the glide that keeps the drawer glide wheel in place. Line up the holes in the glides so that the end with the wheel comes flush with the front edge of the Table Top Stick.

C. Attach the "L" brackets to the top of the glide supports using 5/8" #7 screws. Use hole rather than slot.

Note: Glides are marked right/left with imprint behind wheel.

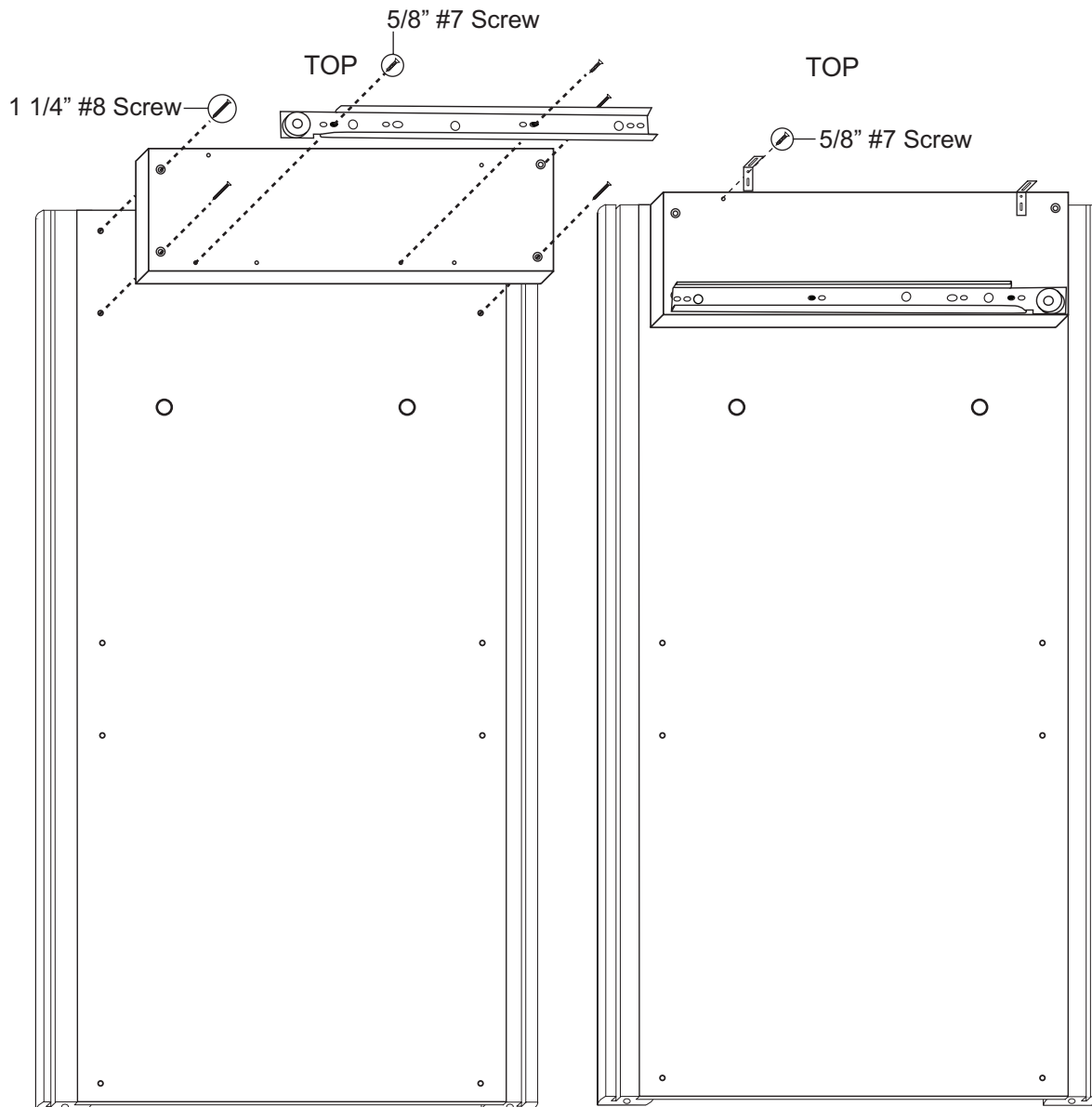

STEP 6

- A. Lay Back Panel flat on a smooth surface with holes up.
- B. Attach Side Panels with 1 3/4" machine screws (bolts) and hex nuts. After inserting bolts(s) thru the holes in the Side Panels, thru the holes in the long edges of the Back Panel, place a hex nut on the tip of your finger, align nut with bolt and tighten.
- C. Look ahead to step 7 which shows side panels attached to back panel.

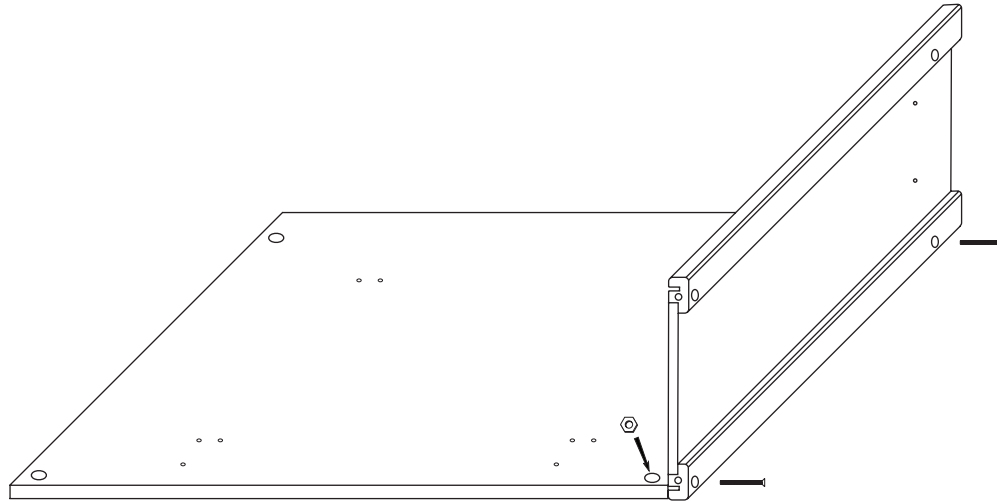

STEP 7

- A. Invert cabinet assembly from step 6.
- B. Take the Top Front Brace (with magnet blocks), insert the pins in the brace ends into the slots on the inside of the front legs of the Side Panel and slide down until the brace is aligned with the set of holes in the Side Panel as illustrated.
- C. Secure brace with 1 3/4" machine screws and hex nuts as in step 6.

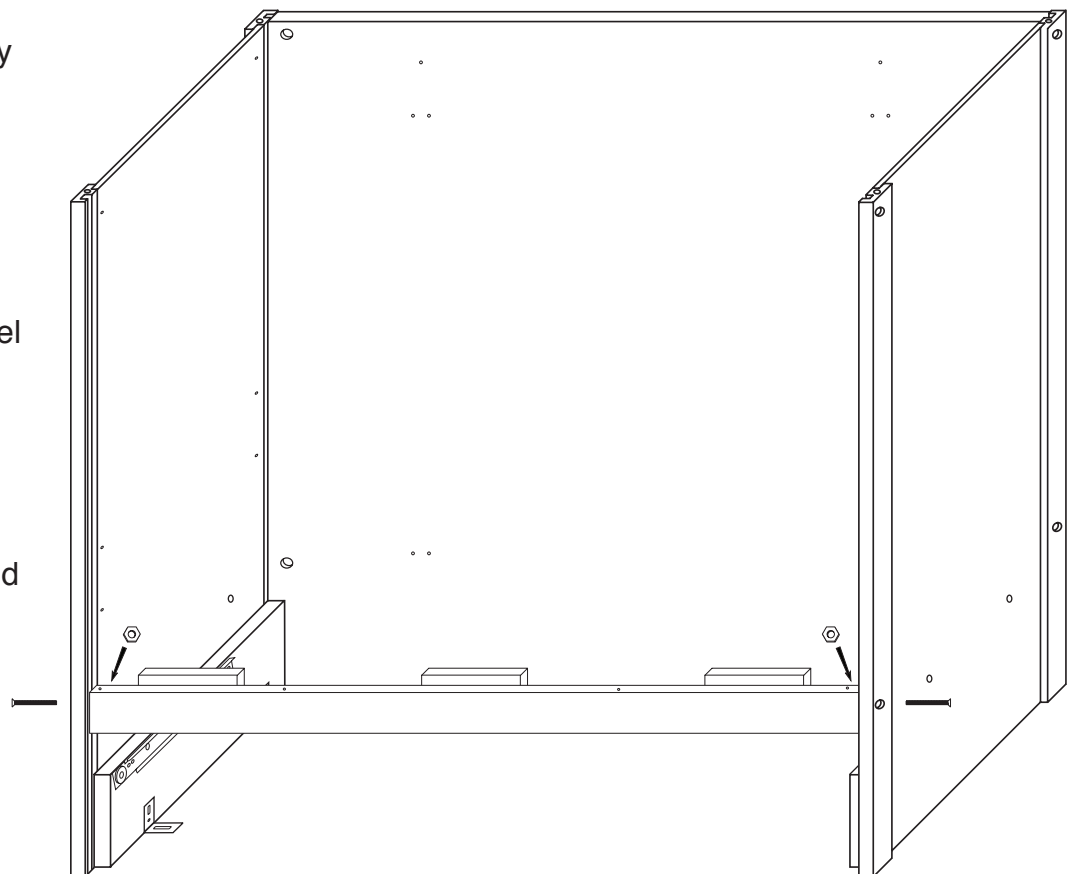

STEP 8

- A. Install Doors by fitting the pins in the top of the door into the holes in the Top Front Brace.
- B. Place washers on the pins on the bottom of the doors, then fit the Bottom Front Brace onto the pins and secure the brace using 1 3/4" machine screws and nuts as in illustration 8A.
- C. Tap two 1" pins into the back panel, two into the holes on the inside of the Bottom Front Brace and two into each Side Panel as in illustration 8B. These will hold the Bottom Shelf.

ILLUSTRATION 8A

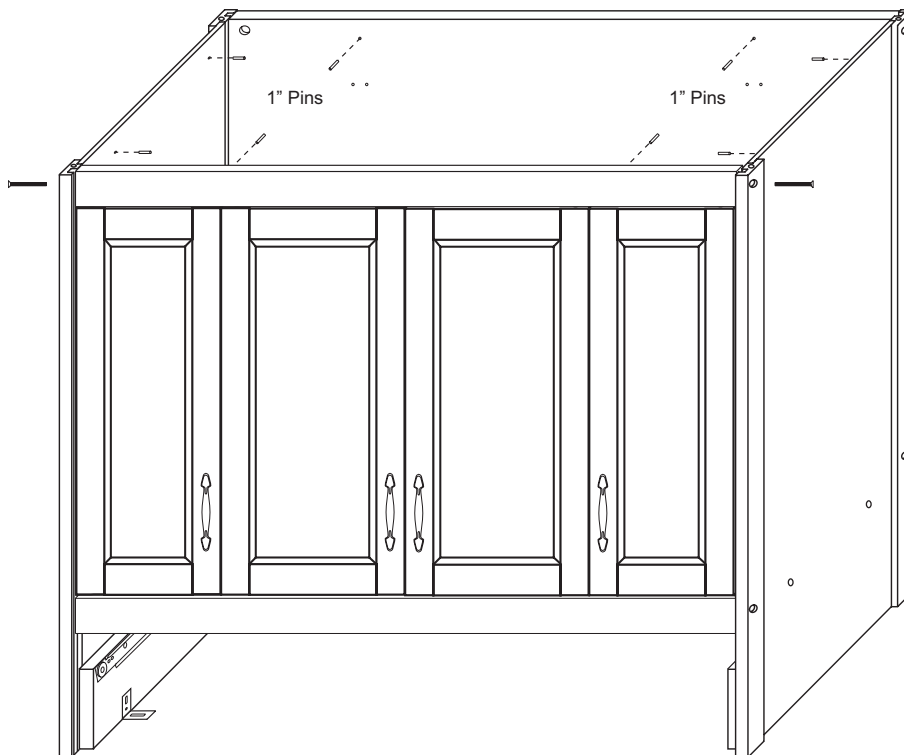
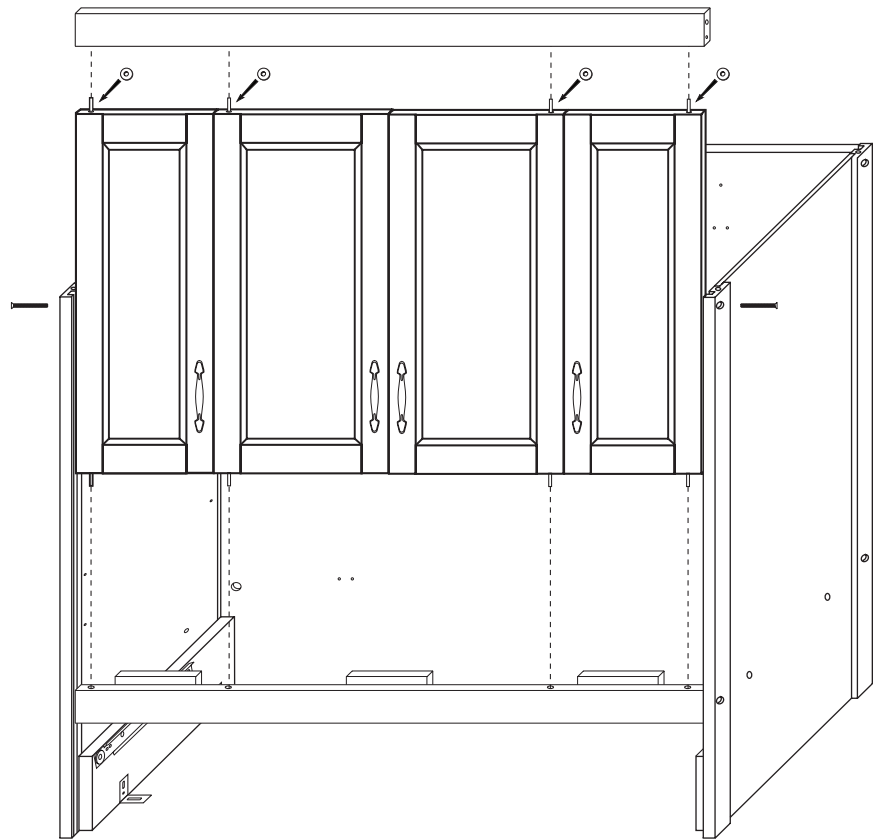
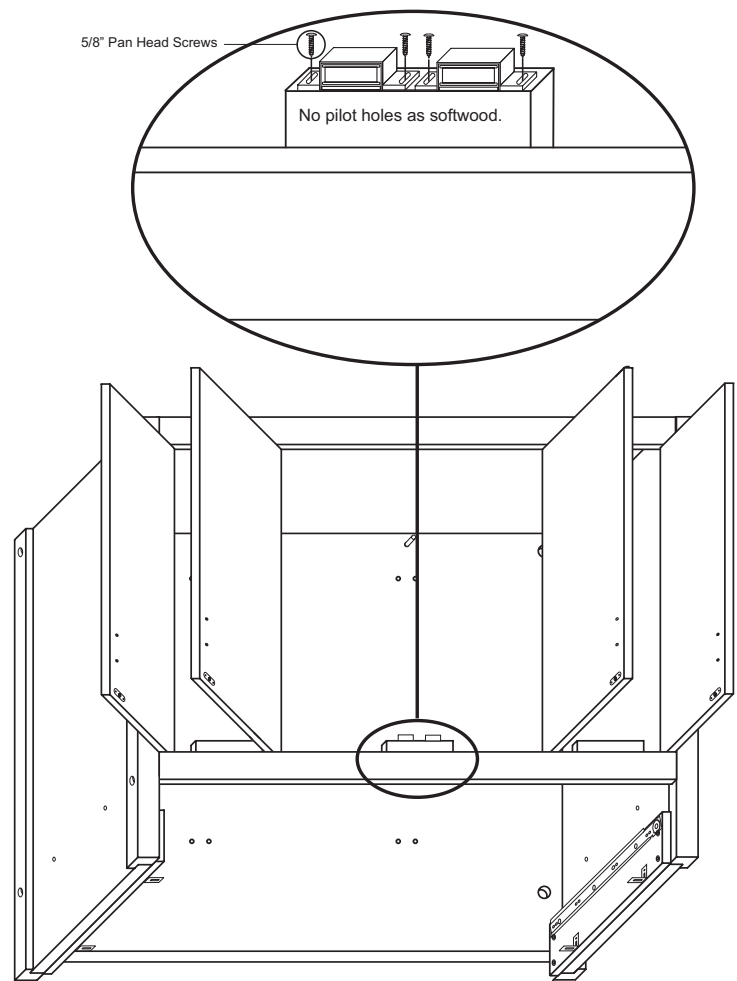

ILLUSTRATION 8B

STEP 9

- A. Stick magnet to magnet plate on a door.
- B. With all other doors open, close the door. The magnet should be positioned over the wooden block on the bottom of the top front brace. Hold the magnet in place with your thumb, and open the door. The magnet will be in the correct position on the block.
- C. Secure magnet with the two round head screws in the magnet packet. Center screws in the slot in the magnet. This will allow adjustment later, if needed.
- D. Repeat these steps for all the doors.



STEP 10

- A. Insert and tap caster sockets with hammer until the teeth grab the wood. **DON'T POUND SOCKET FLAT OR CASTER SHAFT WILL NOT ENTER.**
- B. Insert casters and seat by pushing straight downward with heel of your hand, or tap into place with a hammer. Don't be afraid to give them a good downward whack on the solid metal part of the caster!
- C. Locking wheels usually go on front.

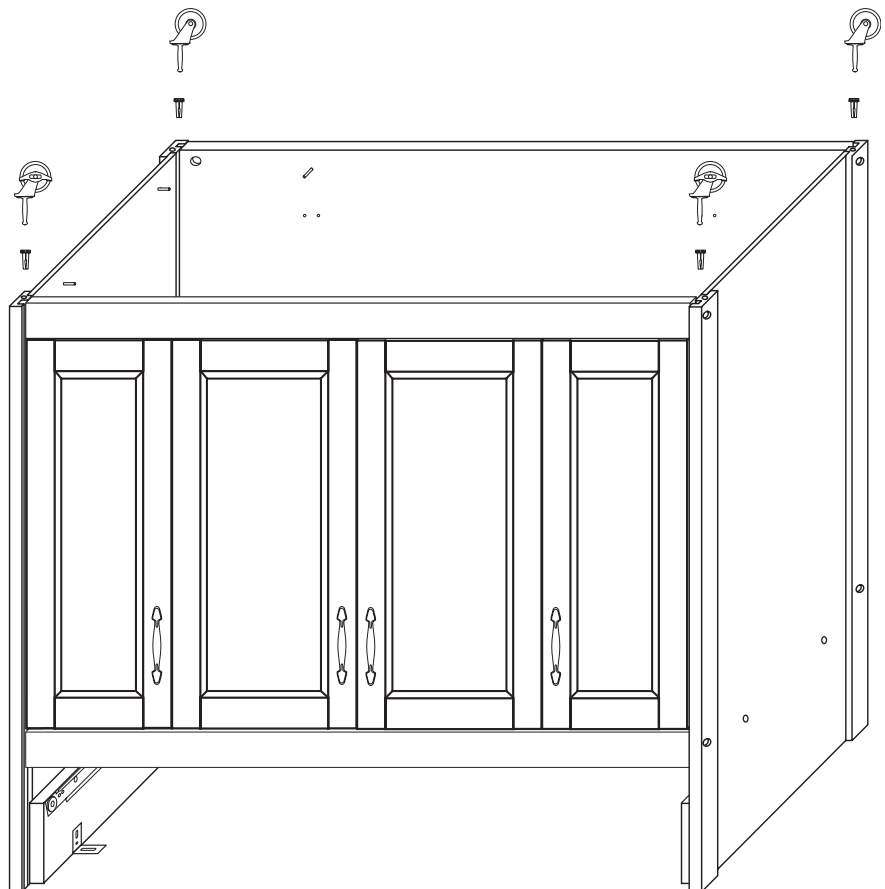

STEP 11

A. Upright unit.

B. Determine if you want the Spice Rack on the left or right Side Panel. The Handle/Towel Bar will go on the other. Attach the Spice Rack to the Side Panel with two 1" x #8 screws from inside the panel. Place a washer over the screw so that so that the head won't pull through the side panel.

C. Attach Towel Bar to the other Side Panel with 1" #8 screws from inside the Side Panel. Place a washer over each screw.

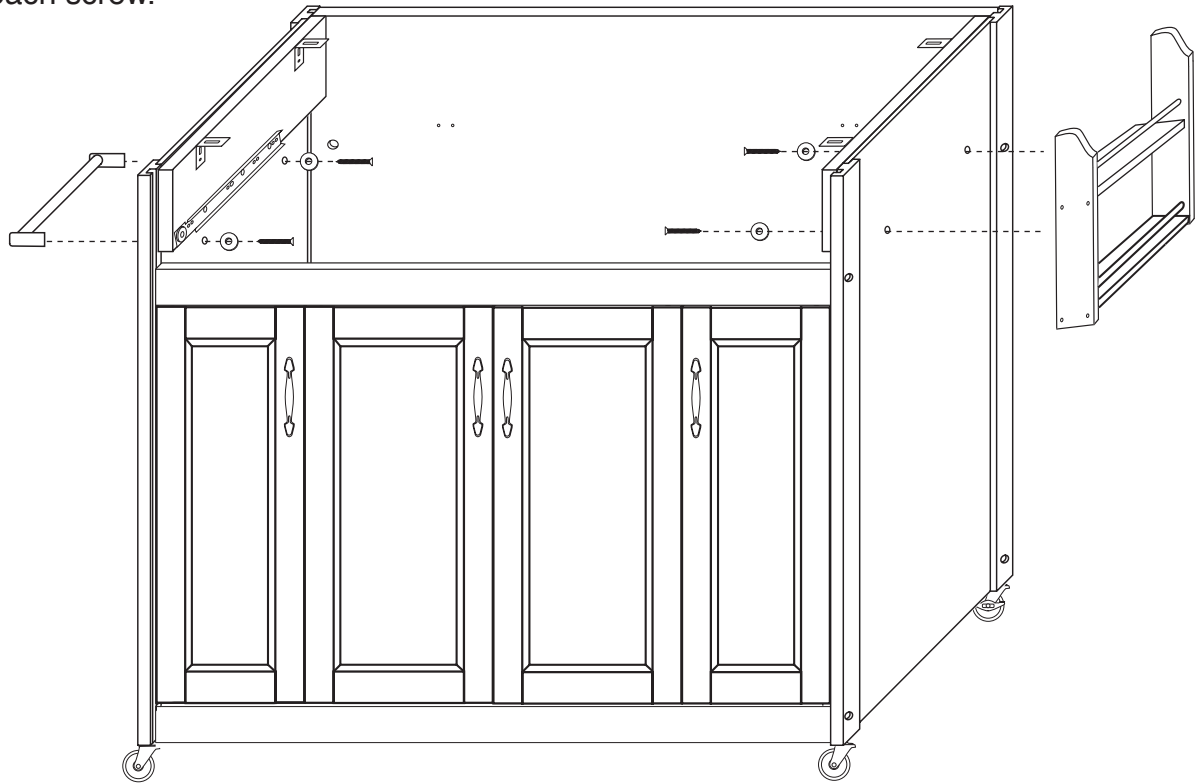

STEP 12

A. Angle the Bottom Shelf as necessary to pass it through the opening in the cabinet top until it rests on the pins installed in step 8B.

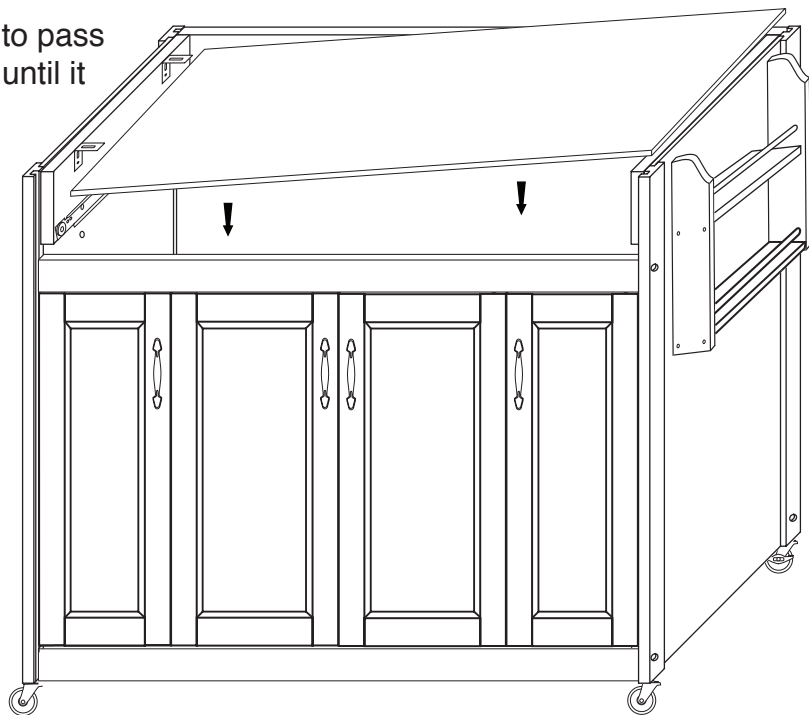

STEP 13

A. Tap 1" pins into the 4 sets of holes in the Back Panel. B. Just above the Bottom shelf on the inside of the Bottom Front Brace there are two sets of holes. Tap 1" pins into these holes.

C. On the Inside face of the Top Front Brace there is a hole adjacent to each of the magnet blocks for the outside doors. Tap one 1" pin into each hole.

D. Choose the height you want your middle shelves, then tap the 2" pins in accordingly on the Cabinet Dividers. For Side Panels, use the metal shelf pins.

E. Slide the Cabinet Dividers between the sets of pins in the Back Panel and the pins in the Front Braces until dividers rest on the Bottom Shelf. Make sure the edge banding faces out.

NOTE: Eight 2" pins are provided in case you want the center middle shelf & the side middle shelves at different heights.

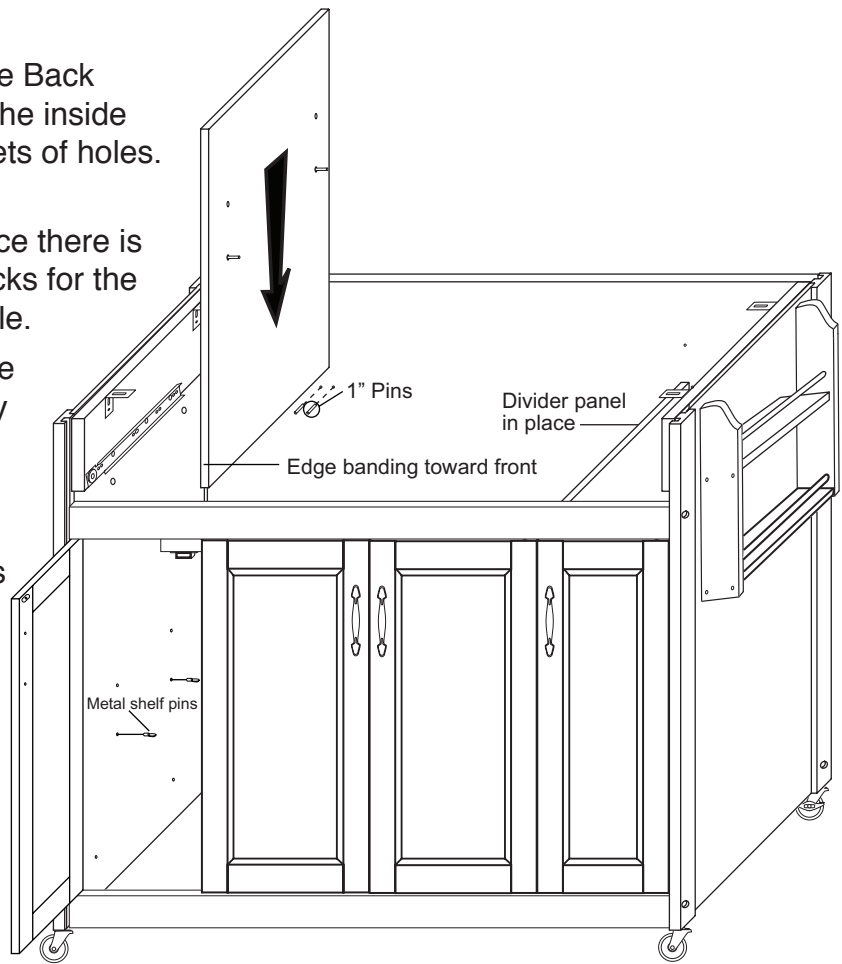

STEP 14

A. Invert Table Top on a smooth flat surface and make a large (X) mark over each of the 4 pilot holes in the bottom. Make marks about 1/2-1" long. These marks will help you align the cabinet with the pilot holes in the bottom of the Top.

B. Place the Cart Top on the cabinet. Open the outside doors. Maneuver the Cart Top so that the (X) marks/pilot holes in the bottom of the Top align with the holes in the "L" brackets. Secure top to "L" brackets with 5/8" #7 screws.

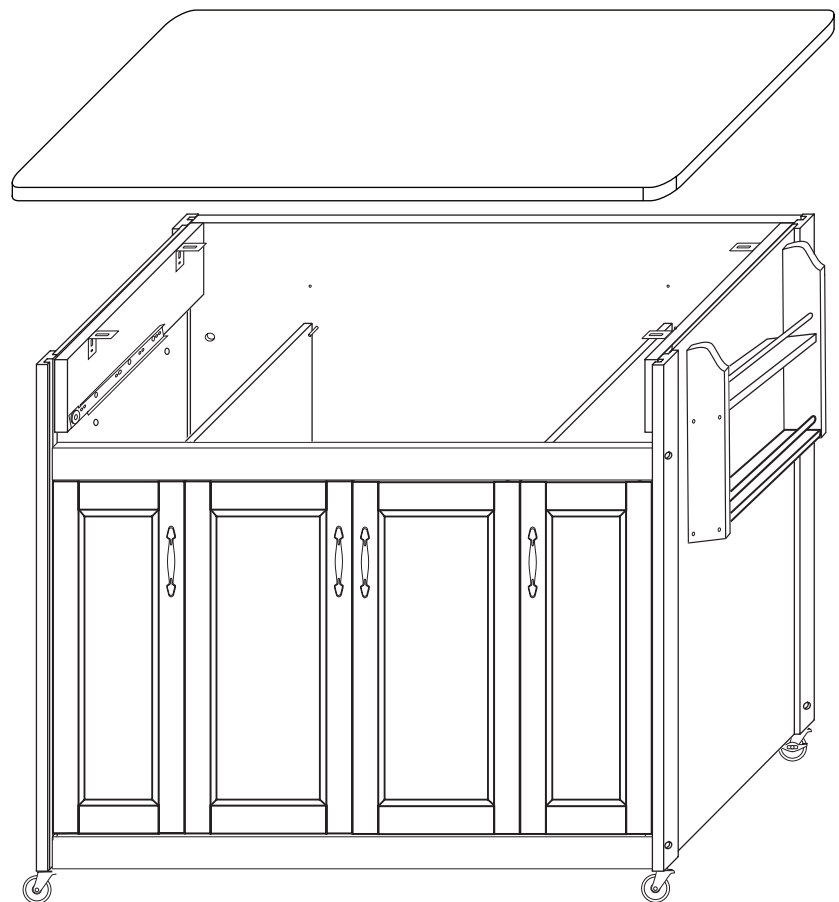

STEP 15

- A. Slide the Drawer into the front of the cart. Make sure the drawer moves freely, then retighten all bolts/nuts.
- B. Tap in the 5/8 wooden plugs into the holes on the legs.
- C. Install Small Middle and Center Shelves simply by sliding them in, edge banding out.
- D. Illustration 15B shows completed 54230.

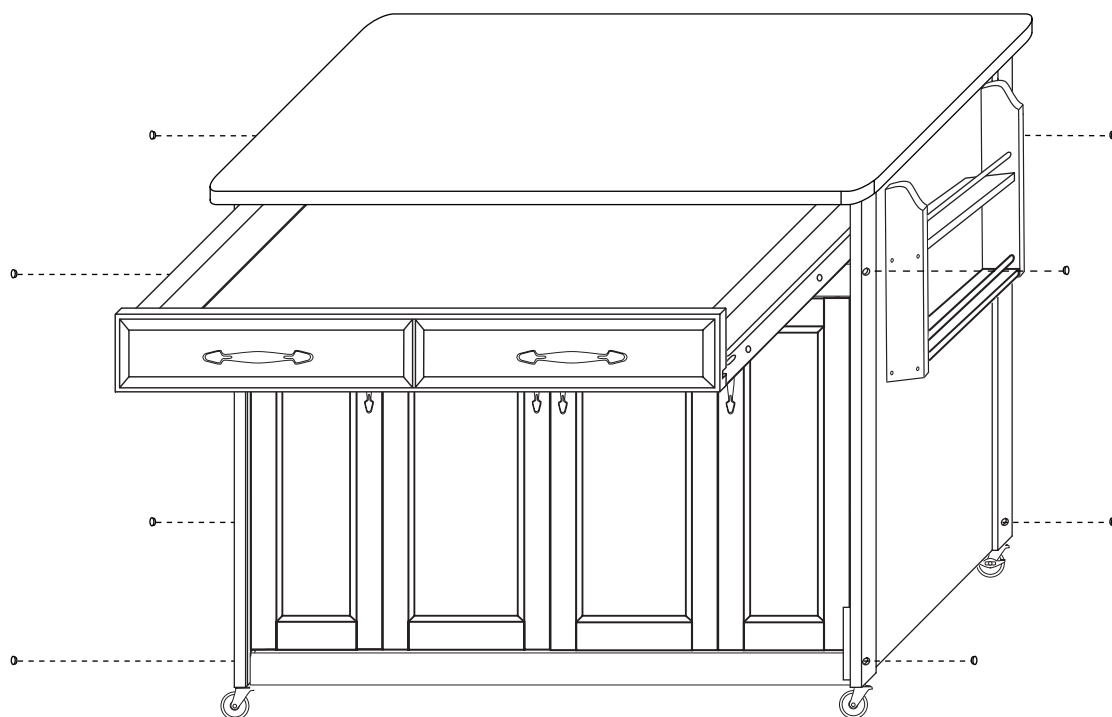

ILLUSTRATION 15A

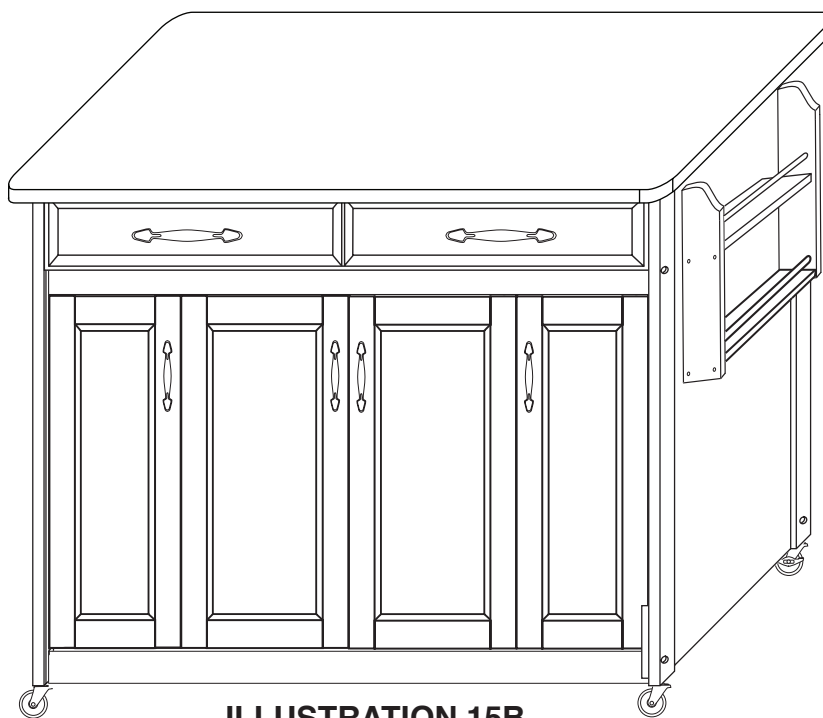

ILLUSTRATION 15B



For continued beauty and long life of your Catskill Craftsmen cart, we recommend Catskill Craftsmen's Butcher Block Oil.

Our Butcher Block Oil is available directly from Catskill Craftsmen's factory. For one eight ounce (8 fl. oz.) bottle, which is sufficient for two applications, simply send \$6.95 along with the completed coupon to the address below. Visit us online at www.catskillcraftsmen.com to browse our assortment of butcher block care products. Visa and Mastercard are accepted online .



Catskill Craftsmen, Inc.
15 West End Ave.
Stamford, NY 12167-1296



BUTCHER BLOCK OIL COUPON

Please send me _____ # of bottle(s) of the Catskill Craftsmen Butcher Block Oil at \$6.95 per bottle. My check or money order is enclosed for a total of \$ _____.

Item code: 54230

Name _____

Address _____

City _____

State _____ Zip _____

Please make checks payable to Catskill Craftsmen Inc. 15 West End Ave., Stamford, NY 12167-1296