

GUARDIAN

FALL PROTECTION

PERFORMANCE SAFETY GEAR

Guardian Fall Protection Kent, WA
800-466-6385 www.guardianfall.com

GENERAL SYSTEM SELECTION CRITERIA: Selection of fall protection shall be made by a Competent Person. All fall protection equipment shall be purchased new and unused.

The equipment is designed for use as a part of a personal fall protection system. Components shall not be used for any other operation other than that which it has been designed and approved.

Fall Arrest Systems shall be designed to comply with OSHA or applicable state regulatory limitations. Systems must be used in a compliant manner.

Fall Restraint systems shall be designed by a Qualified Person, and must be installed and used under the supervision of a competent person.

Consult a doctor if there is any reason to doubt a user's ability to withstand and safely absorb fall arrest forces. Age, fitness, and health conditions can seriously affect the worker should a fall occur. Pregnant women and minors should not use this equipment.

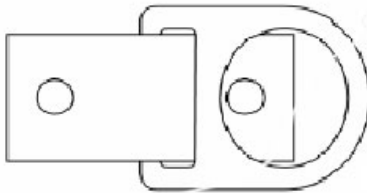

D-Ring Anchor Plate

**DO NOT THROW AWAY THESE INSTRUCTIONS!
READ AND UNDERSTAND BEFORE USING EQUIPMENT!**

This manual should be read and understood in its entirety, and used as part of a training program as required by OSHA or any applicable state regulatory agency.

This and any other included instructions must be provided to the users of the equipment. The user must understand the proper equipment use and limitations.

This product meets all applicable OSHA and ANSI standards for fall protection.

WARNING!

DO NOT:

- Do not alter or misuse this equipment.
- Do not use combinations of components or subsystems that may affect or interfere with the safe, compatible function of each other.
- Do not expose the equipment to chemicals which may produce a harmful effect or degrade the equipment. Consult manufacturer in cases where doubt exists.
- Do not use the equipment around moving machinery or electrical hazards unless specifically designed for such use.
- Do not use the equipment around sharp edges or abrasive surfaces unless intended for such use.

TRAINING REQUIREMENTS: The employer shall provide a training program for each employee who might be exposed to fall hazards. The program shall enable each employee to recognize the hazards of falling and shall train each employee in the procedures to be followed in order to minimize these hazards. Relevant Federal, State, and local regulatory requirements, procedures, and standards shall also be a part of training.

The employer shall ensure that each employee has been trained, as necessary, by a Competent or Qualified Person in the nature of fall hazards in the work area, the correct erecting, maintaining, disassembling, and inspection of the fall protection systems being used, and the use of personal fall arrest systems.

RESCUE PLAN: The user is required to have a rescue plan and the means at hand to implement it when using the equipment. The plan shall be project specific. Employees shall be trained in self-rescue or alternate means shall be provided for prompt rescue in the event of a fall.

IF EQUIPMENT IS SUBJECTED TO A FALL: Remove the equipment from service immediately if it has been subjected to the forces of a fall arrest. Contact your distributor or Guardian about policies regarding replacement of Guardian components involved in a fall.

INSPECTION:

- Only the manufacturer of this equipment or persons or entities authorized in writing by the manufacturer shall make repairs to fall protection equipment.
- The date of first inspection should be recorded by the employer on the equipment, and any serial numbers shall be recorded on the Inspection Log.
- Formal inspections shall be made by either a Competent or Qualified Person on at least a semi-annual basis.

PRIOR TO EACH USE:

- Fall protection equipment shall be inspected by the user for defects, damage, or deterioration.
- Any suspected defective equipment shall be removed from service.
- If the manufacturer's label is not legible or is missing, the equipment shall be removed from service. Fall protection equipment shall be removed from service upon evidence of defects, damage, or deterioration, or upon expiration of the manufacturer's specified service limits, whichever comes first.

WARNING!

Consult with your doctor if there is reason to doubt your fitness to safely absorb the shock from a fall arrest. Age, fitness, and health conditions can seriously affect a worker's ability to withstand falls. Pregnant women or minors must not use any Guardian Fall Protection equipment.

MAINTENANCE, CLEANING, AND STORAGE: Repairs to equipment can be made only by a Guardian representative or person or entity authorized by Guardian. Contact Guardian for maintenance and repair. Cleaning after use is important for maintaining the safety and life of the equipment. Cleanse the equipment of all dirt, corrosives, and contaminants. If the equipment cannot simply be wiped clean use a mild soap and water. Rinse, wipe, and hang to dry. Store equipment where it cannot be affected by heat, light, excessive moisture, oil, chemicals, or other degrading elements.

DESCRIPTION OF PRODUCT:

D-ring Anchorage Connector, forged steel D-ring, stainless steel anchorage plate, 9/16-inch diameter mounting holes.

PRODUCT APPLICATION INFORMATION:

The D-ring Anchorage Connector is designed to be used as an anchorage connector for personal fall arrest, restraint, work positioning, or suspension. D-ring Anchorage Connectors may be used for a horizontal lifeline if the system is designed, installed and used under the supervision of a qualified person. Do not hang, lift or support tools or equipment from any D-ring Anchorage Connector.

- **PERSONAL FALL ARREST:** Means the product is used as a component of a personal fall arrest system to protect the user in the event of a fall. PFAS typically include a full body harness and a connecting component (energy absorbing lanyard). Maximum permissible free fall is six feet.
- **RESTRAINT:** Means the product is used as a component of a restraint system to prevent the user from reaching a fall hazard. Restraint systems typically include a full body harness and a lanyard or restraint line. **NO VERTICAL FREE FALL IS PERMITTED**
- **WORK POSITIONING:** Means the product is used as a component of a work positioning system to support the user at a work position. Work positioning systems typically include a full body harness, positioning lanyard, and a back-up personal fall arrest system. Maximum permissible free fall is two feet.
- **RESCUE:** This product IS NOT RATED for use as a component of a rescue system.

LIMITATIONS:

Consider the following application limitations before using this equipment.

- **Capacity:** The anchorage connectors are designed for use by persons with a combined weight (clothing, tools, etc.) of no more than 310lbs. No more than one personal protective system may be connected at one time.
- **Free Fall:** Personal fall arrest systems (PFAS) used with this equipment must be rigged to limit the free fall to six feet as called out in ANSI Z359.1. Only qualified and trained personnel, on the proper use of fall protection such as this anchor, are allowed to use this product. **Restraint systems** must be rigged that no vertical free fall is possible. **Work positioning systems** must be rigged so that free fall is limited to two feet or less. **Rescue systems** must be rigged so that no vertical free fall is possible.
- **Fall Clearance:** There must be sufficient clearance below the user to arrest a fall before the user strikes the ground or other obstruction. The clearance required is dependent on some or all of the following factors. A hazard assessment by a trained and competent person is recommended before any work is started that would include the use of fall protection.

Consider When Calculating Distance:

- Deceleration Distance
- Movement of harness attachment element (D-ring)
- Free Fall Distance
- Worker Height (how tall the worker is could affect the free fall distance)
- Elevation of Anchorage Connector
- Connecting Subsystems Length

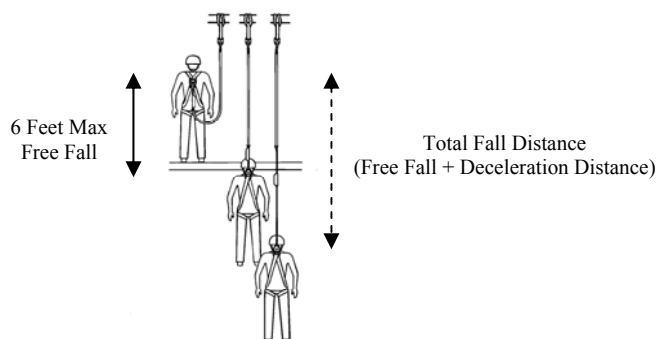

APPLICABLE STANDARDS:

Refer to potential applicable standards. Standards might include OSHA regulations depending on the type of work, and also might include state regulations if applicable. Consult regulatory agencies for more information on personal fall arrest systems and associated components. This product is designed to comply with OSHA and ANSI Z359.1 standards when used properly, and in accordance with manufacturer's instructions.

LIMITATIONS CONTINUED:

- **Swing Falls:** Swing falls occur when the anchorage point is not directly above the point where a fall occurs. The force of striking an object in a swing fall may cause serious injury or death. Minimize the risk of swing falls by working as close to the anchorage point as possible. Do not permit a swing fall if injury could occur. **Swing falls will significantly increase the clearance required when a self retracting lifeline or other variable length connecting system is used.**
- **Potential Environmental Hazards:** Use of fall protection equipment in areas with environmental hazards may require additional precautions to prevent injury to the user or damage to the equipment. Hazards may include but are not limited to: chemicals, corrosive environments, high voltage power lines, gases, moving machinery, and sharp edges.

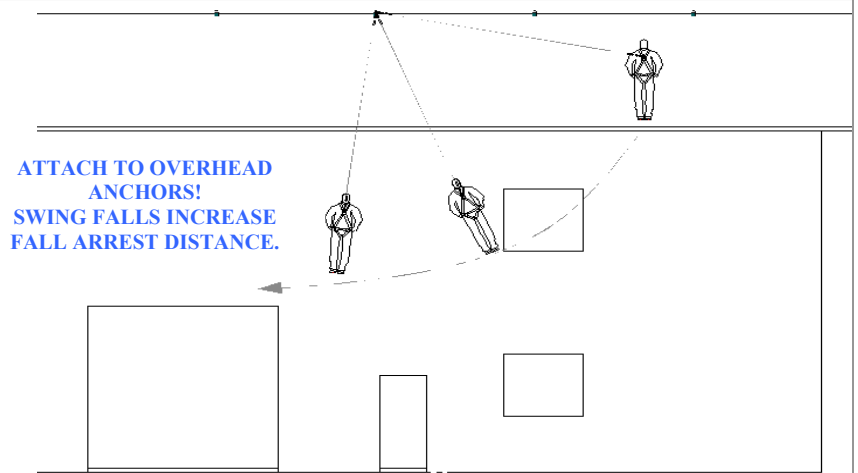

SYSTEM REQUIREMENTS:

- **Compatibility of Components:** Guardian Fall Protection equipment is designed to be used with Guardian approved components. Please contact Guardian if you have a question regarding compatibility. Making substitutions without approval from Guardian Fall Protection may lead to injuries and or death by compromising the safety and reliability of the complete system. A Qualified person can make a determination on compatibility of equipment from different manufacturers. If in doubt, please contact Guardian Fall Protection for clarification.
- **Compatibility of Connectors:** Connectors (D-rings, hooks, carabiners) must be capable of supporting at least 5,000 lbs. (22kN). Do not use equipment that is not compatible. Non-compatible connectors may unintentionally disengage. Self locking snap hooks and carabiners are required by ANSI and OSHA. Connectors must be compatible in size, shape, and strength.
- **Making Connections:** Only use self-locking snap hooks and carabiners with any Guardian Fall Protection equipment. Do not use equipment that is not compatible. If you have any questions on compatibility, please call Guardian Fall Protection at 800.466.6385.

WARNING!

Large throat opening snap hooks should not be connected to standard size D-rings or similar objects which will result in a load on the gate if the hook or D-ring twists or rotates. Large throat snap hooks are designed for use on fixed structural elements such as rebar or cross members that are not shaped in a way that can capture the gate of the hook.

PERSONAL FALL ARREST INFORMATION:

- **Personal Fall Arrest System (PFAS):** Personal fall arrest systems used with this equipment must meet applicable state, federal, OSHA, and ANSI requirements. A full body harness must be worn when this equipment is used as a component of a personal fall arrest system. As required by OSHA, the personal fall arrest system must be capable of arresting the user's fall with a maximum arresting force of 1,800 lbs., and limit the free fall to six feet or less.

WARNING!

If overhead tie off is not feasible, and an approved system has the potential for a free fall greater than six feet, and up to a maximum of ten feet, Guardian Fall Protection recommends using a personal fall arrest system incorporating a Guardian Fall Protection Heavy Duty Shock Absorbing Lanyard. The Heavy Duty Lanyard is designed to keep fall arresting forces below the required standard of 1,800 lbs. Standard type lanyards will generate impact fall forces in excess of the legal requirement.

ANCHORAGE STRENGTH REQUIREMENT:

The anchorage strength required is dependent on the application. Following are anchorage strength requirements for specific applications. Ensure that any anchorage point used in a personal fall protection system meet the following requirements.

- **Fall Arrest:** The structure to which the anchorage connector is attached must sustain static loads applied in the directions permitted by the fall arrest system of at least 3,600lbs. with certification of a qualified person, or 5,000lbs. without certification. Refer to OSHA and ANSI for specific definition. This anchor is to be used by one worker only. Do not tie off equipment. Anchorages used for attachment of a personal fall arrest system shall be independent of any anchorage being used to support or suspend platforms.
- **Restraint:** The structure to which the anchor point is attached must sustain static loads applied in the directions permitted by the restraint system of at least 3,000lbs. When more than one restraint system is attached to an anchorage, the strengths stated above must be multiplied by the number of restraint system attached to the anchorage.
- **Work Positioning:** The structure to which the anchor point is attached must sustain static loads applied in the directions permitted by the work positioning system of at least 3,000lbs., or twice the potential impact load, whichever is greater. When more than one work positioning system is attached to an anchorage, the strengths stated above must be multiplied by the number of work positioning systems attached to the anchorage.

INSPECTION OF D-Ring Anchorage Connectors:

WARNING!

If inspection reveals an unsafe or defective condition, remove the product from service and destroy it immediately.

- **Before each use of this equipment inspect it according to the following guidelines:**
A formal inspection of fall protection products/components must be performed at least every six months by a competent person other than the user. The frequency of formal inspections should be based on conditions of use or exposure. Record the inspection results in the inspection and maintenance log at the end of this manual.

Inspecting the D-ring Anchorage Connectors:

- Step 1.** Inspect the D-ring for damage or corrosion. Inspect for cracks or wear that may affect strength and operation.
- Step 2.** Inspect the Anchorage Plate for damage or corrosion. Inspect for cracks or wear that may affect strength and operation.
- Step 3.** Inspect the attaching fasteners. Fasteners must hold the Anchorage Plate securely to the anchorage. Inspect for damage or corrosion.
- Step 4.** Inspect the system components according to the manufacturer's instructions.
- Step 5.** Record the inspection results in the inspection log at the end of this manual.

WARNING!

PLAN THE FALL PROTECTION SYSTEM:

Before installation plan your system. Consider all factors that will affect your safety during use of this equipment. The following list gives important points to consider when planning your system:

- **Anchorage:** Select a rigid anchorage capable of supporting the loads no less than 5,000 lbs. per worker attached.
- **Sharp Edges:** Avoid working where system components may be in contact with, or abrade against, unprotected sharp edges.
- **After a Fall:** Components which have been subjected to the forces of arresting a fall must be removed from service and destroyed.
- **Rescue:** The employer must have a rescue plan when using this equipment. The employer must have the ability to perform a rescue quickly and safely.

INSTALLATION REQUIREMENTS:

The following requirements outline the proper installation procedures to be followed.

- **Location:** Select a location on an appropriate strength anchorage that will provide overall safety and proper loading. The anchorage must be free of deformities or defects that may weaken the structure.

WARNING!

If inspection reveals an unsafe or defective condition, remove the D-ring Anchorage Connector from services and destroy it immediately.

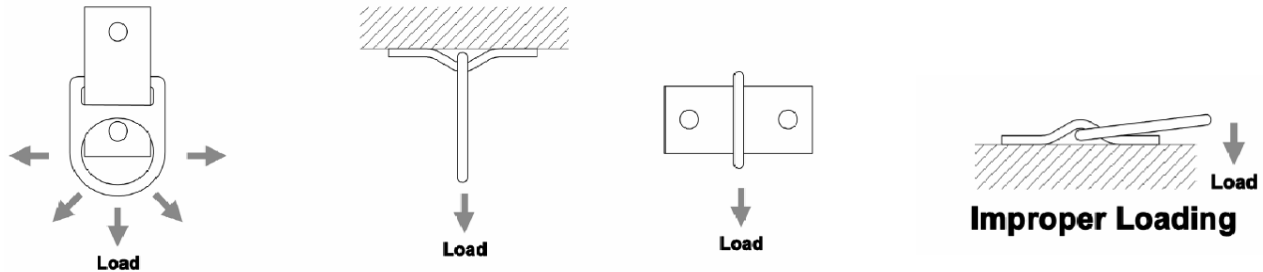

Proper Loading

- **Structure:** The structure to which the anchorage connector is attached must be void of any cracks, corrosion, and defects that may weaken the structure. Only use these anchorage connectors in a horizontal fashion that will not allow the anchorage connector to slide down the structure. Do not use these anchorage connectors in a vertical application. Serious injury is possible in the event that the anchorage were to slide down a structure.
- **Installing the D-ring Anchorage Connector:**
 - The D-ring Anchorage Connector may be attached to the structure using fasteners or welding.
 - Use fasteners that will meet the strength requirements specified in this manual.
 - Guardian Fall Protection recommends using 1/2 -inch diameter, grade 5 bolts.
 - Welded installations must be installed by a certified professional welder in accordance with the latest codes and specifications of the American Welding Society.
 - Welds must support the loads specified in this manual. Do not weld the D-ring. The D-ring must swivel freely.
 - Welded installations should be verified by a qualified person for strength by calculation or by proof loading the installation in the intended direction(s) of intended use to 3,600 lbs.
 - Protect finished welds from corrosion with paint or other finish. Do not electroplate the D-ring.
 - Installations should be verified by a qualified person for strength by calculation in the intended direction(s) or intended use.

WARNING!

Failure to install and use in a compliant manner, or violation of manufacturer's recommendations, can result in serious injury or death.

- **Making Connections:**
 - When using a hook to connect to the D-ring Anchorage Connector, ensure roll-out cannot occur.
 - Roll-out occurs when interference between the hook and mating connector causes the hook gate to unintentionally open and release.
 - Self-locking snap hooks and carabiners should be used to reduce the possibility of roll-out. Do not use hooks or connectors that will not completely close over the attachment object.

Connecting to the Anchorage Connector:

- Connect to the installed anchorage connector with a self locking snap hook or self locking carabiner only.
- Connect only compatible components and equipment to the anchorage connector.
- Do not use a knot to connect a lifeline to the anchorage connector.
- Do not pass lanyard or lifeline through the anchorage connector D-ring and hook back into the lanyard or lifeline itself.
- Never connect more than one personal protective system to a single anchorage connector.

TRAINING:

It is the responsibility of the user and the purchaser of this equipment to assure that they are familiar with these instructions, trained in the correct care and use of, and are aware of the operating characteristics, application limits, and the consequences of improper use of this equipment.

WARNING!

Training should be conducted without exposing anyone to a fall hazard. Training should be repeated on a periodic basis in accordance with your organizations policy and compliance with OSHA regulations.

SPECIFICATIONS:

D-ring Anchorage Connector

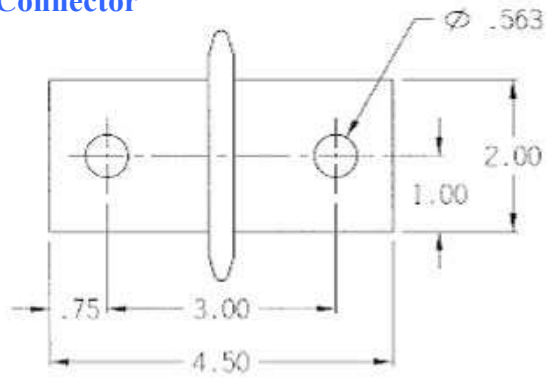

Materials:
Stainless Steel Plate
Steel O-rings

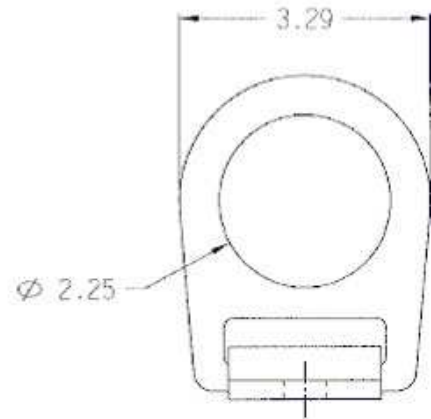
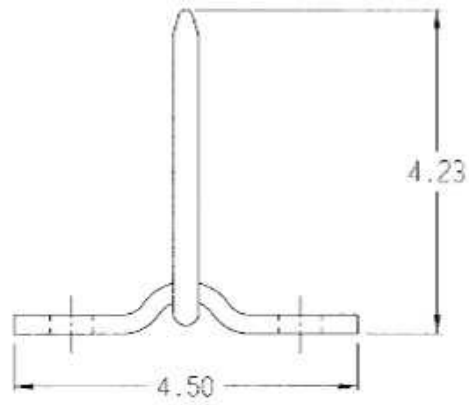

D-ring Anchorage Connector Labels

Refer to written installation instructions before use.

- Anchorage structures shall be capable of withstanding 5,000lbs.
- Connecting systems should be protected from sharp or abrasive surfaces. Do not make incompatible connections, such as tying rope directly to attachment point.
- Warning: Avoid physical hazards such as thermal, electrical, or chemical elements that could impact the integrity of the equipment.
- Material: Stainless Steel Plate, Steel D-ring.
- Min. Breaking Strength: 5,000lbs.
- Max. user weight (including tools): 310lbs.
- One worker per anchor.



Meets all applicable ANSI Z359.1/A10.32 standards
Guardian Fall Protection, Kent, WA

Model # _____ Manuf. Date _____
DO NOT REMOVE THIS LABEL!

Warning! Follow the manufacturer's instructions included with the equipment at time of shipment from the manufacturer before using.

- This anchor point is designed for use as a part of a planned personal fall arrest or fall restraint system. Make only safe, compatible connections.
- Warning: **REMOVE FROM SERVICE** if subjected to a fall arrest or if unit fails inspection. Visually inspect before each use for cracks, excessive wear, deterioration, or structural incapacities.

USER MUST INSPECT BEFORE EACH USE. Competent Person to Inspect and Initial at least every 6 months. **Date of First Use**

YR.	J	F	M	A	M	J	J	A	S	O	N	D

Guardian Fall Protection, Inc.
800-466-6385
26513 79th Ave. S.
Kent, WA 98032
www.guardianfall.com