



ALUMINUM TANDEM MASTER CYLINDER

SPECIFICATION SHEET • INSTRUCTIONS

Master Cylinder Part Number: 260-4893
Master Cylinder Kit Part Number: 260-4894



Component	Specifications
Piston Bore Diameter	1-1/16 inches
Maximum Piston / Push Rod Travel	1.35 inches
Primary Piston Stroke: "A" Outlet	.90 inches
Secondary Piston Stroke: "B" Outlet	.45 inches
Primary Outlet Port "A"	1/2-20 inverted flare
Secondary Outlet Port "B"	9/16-20 inverted flare

WARNING

IT IS THE RESPONSIBILITY OF THE PERSON INSTALLING ANY BRAKE COMPONENT OR KIT TO DETERMINE THE SUITABILITY OF THE COMPONENT OR KIT FOR THAT PARTICULAR APPLICATION. IF YOU ARE NOT SURE HOW TO SAFELY USE THIS BRAKE COMPONENT OR KIT, YOU SHOULD NOT INSTALL OR USE IT. DO NOT ASSUME ANYTHING. IMPROPERLY INSTALLED OR MAINTAINED BRAKES ARE DANGEROUS. IF YOU ARE NOT SURE, GET HELP OR RETURN THE PRODUCT. YOU MAY OBTAIN ADDITIONAL INFORMATION AND TECHNICAL SUPPORT BY CALLING WILWOOD AT (805) 388-1188, OR VISIT OUR WEB SITE AT WWW.WILWOOD.COM. USE OF WILWOOD TECHNICAL SUPPORT DOES NOT GUARANTEE PROPER INSTALLATION. YOU, OR THE PERSON WHO DOES THE INSTALLATION MUST KNOW HOW TO PROPERLY USE THIS PRODUCT. IT IS NOT POSSIBLE OVER THE PHONE TO UNDERSTAND OR FORESEE ALL THE ISSUES THAT MIGHT ARISE IN YOUR INSTALLATION.

RACING EQUIPMENT AND BRAKES MUST BE MAINTAINED AND SHOULD BE CHECKED REGULARLY FOR FATIGUE, DAMAGE, AND WEAR.

Installation Notes and Precautions

- Always mount the master cylinder to a secure, reinforced element of the chassis. There should be no movement or deflection at the mount point when brake pedal pressure is applied. When using fabricated mounts or pedal linkages, it is important that the alignment of the push rod and piston are kept as straight as possible to prevent side loading the piston against the master cylinder bore
- Be sure the pedal and push rod are adjusted to allow the master cylinder piston to fully retract against the snap ring at the back of the master cylinder bore when the pedal is fully retracted. There should also be adequate pedal travel to fully compress the master cylinder. Pedal return springs and stops are highly recommended.
- Prior to attaching the fluid lines, fill the reservoirs with Wilwood fluid from a new, sealed container and purge any air from the master cylinder. Be sure the cylinder is level during the bleeding operation. If the cylinder is not level when mounted in the vehicle, you can perform this operation prior to attaching the master cylinder to its mount. The diagram illustrates one method of recycling the fluid into the reservoir until all air has been eliminated. Exercise care to not spill or spray brake fluid. Take all proper safety precautions including eye and skin protection and do not position your face directly above the reservoir. This process will assure a quick and effective full system bleed later.
- Once all fluid connections have been made, the complete system must be bled and checked for leaks prior to any test of the vehicle.

Plumbing Notes and Precautions

- Flare nuts to fabricate double flared 3/16" diameter brake lines are included with each master cylinder. Use only double flared lines. Do not attempt to use single flared connections. Standard automotive double flared lines with the correct size fittings can also be purchased pre-made from an auto parts store.
- Use of reinforced flexible lines should be limited to the connection between the fixed chassis and the moving suspension. All other lines along the fixed chassis should be hard steel lines.

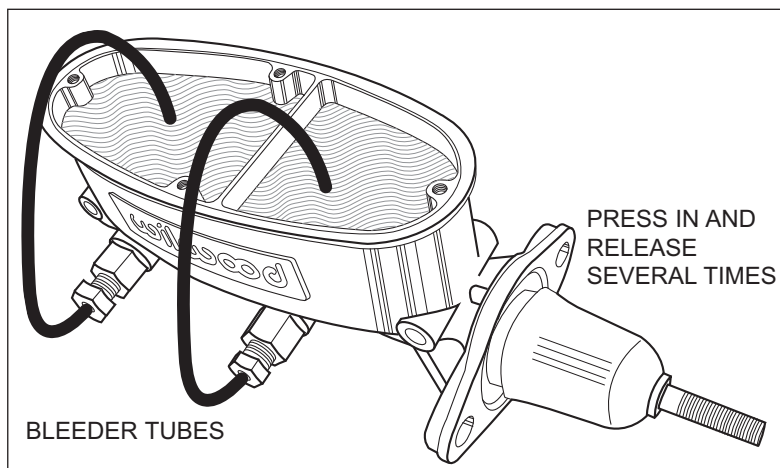

Typical Bleeder Tube Setup and Use

WARNING

THIS COMPONENT IS DESIGNED FOR USE IN CUSTOM BRAKE SYSTEMS ON PERFORMANCE, RACING, AND OTHER SPECIAL PURPOSE BUILT OFF-ROAD VEHICLES. IT IS NOT INTENDED AS A DIRECT REPLACEMENT FOR ANY OEM APPLICATION.

- Connect the primary outlet port "A" to the brakes at the end of the vehicle with the greatest total effective piston bore area. On most vehicles, this will be the front brake line (see note below).
- Connect the secondary outlet port "B" to the brakes at the end of the vehicle with the lesser total effective piston bore area. On most vehicles, this will be the rear brake line (see note below).
- On disc brake applications, where the fluid reservoir is mounted higher than the caliper bleeds, a residual pressure valve is usually not required.
- On disc brake applications, where the fluid reservoir is mounted lower than the caliper bleeds, may require a 2 pound residual pressure valve to prevent fluid drain back and excessive pedal travel.
- All drum brake applications require an inline 10 pound residual pressure valve.
- Use an adjustable proportioning valve to set the front to rear brake bias.

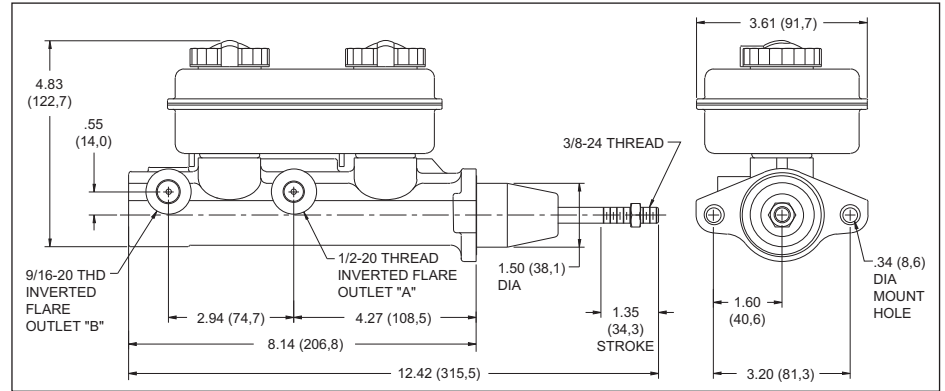

Tandem Master Cylinder, Mounting Dimensions

CALCULATING EFFECTIVE PISTON BORE AREA TO DETERMINE PLUMBING

To determine the effective piston bore area of any caliper, you must first calculate the area for each piston bore found on one side of the caliper. Use the formula "Area = (bore x bore) x .785" for each piston bore size. Then, add the areas of all pistons on that one side of the caliper to determine the total effective piston bore area. Compare the difference between the front and rear calipers and attach the line from the primary outlet "A" to the calipers at the end of the vehicle with the greater total effective piston bore area.

Tandem Master Cylinders, Components and Accessories

Part No.	Description
260-4893	1-1/16" Bore Tandem Outlet Master Cylinder only
260-4894	1-1/16" Bore Tandem Outlet Master Cylinder with push rod, retainer, and boot
260-4896	1-1/16" Bore Master Cylinder Rebuild Kit
260-1874	2 Pound Residual Pressure Valve
260-1875	10 Pound Residual Pressure Valve
260-8419	Knob Adjustable Proportioning Valve
260-8420	Lever Adjustable Proportioning Valve
250-2406	Firewall Mount Reinforcement Plate
250-3677	Wilwood Pedal Adapter Plate Kit
340-1289	Floor Mount Pedal, 6:1 ratio
340-1290	Forward Swing Mount Pedal, 7:1 ratio
290-0632	Wilwood Hi-Temp 570 DOT 3 Fluid
290-6209	Wilwood EXP 600 Plus Super Hi-Temp Fluid

WARNING • DO NOT DRIVE ON UNTESTED BRAKES BRAKES MUST BE TESTED AFTER INSTALLATION OR MAINTENANCE MINIMUM TEST PROCEDURE

- Make sure pedal is firm: Hold firm pressure on pedal for several minutes, it should remain in position without sinking. If pedal sinks toward floor, check system for fluid leaks. DO NOT drive vehicle if pedal does not stay firm or can be pushed to the floor with normal pressure.
- At very low speed (2-5 mph) apply brakes hard several times while turning steering from full left to full right, repeat several times. Remove the wheels and check that components are not touching, rubbing, or leaking.
- Carefully examine all brake components, brake lines, and fittings for leaks and interference.
- Make sure there is no interference with wheels or suspension components.
- Drive vehicle at low speed (15-20 mph) making moderate and hard stops. Brakes should feel normal and positive. Again check for leaks and interference.
- Always test vehicle in a safe place where there is no danger to (or from) other people or vehicles.
- Always wear seat belts and make use of all safety equipment.