

FOR MODEL

Sidewalk-Pro SP-50
Sidewalk-Pro SP-65

INTRODUCTION.....	3
GENERAL INFORMATION	4
SAFETY	5-6
SPREADER PARTS/DIAGRAMS.....	7-15
OPERATING THE SPREADER	16
BLANK PAGE.....	17
WARRANTY	18
NOTES PAGE	19

Have a question or need assistance?
SnowEx Customer Service
(800) 725-8377

or (586) 756-6555

Monday through Friday 8:00 AM to 4:30 PM EST

Fax: (586) 427-0552

E-Mail: customercare@trynexusfactory.com

Website: www.snowexproducts.com

This manual has been designed for your help. It will assist you and instruct you on the proper set-up, installation and use of this spreader. Refer to the table of contents for an outline of this manual.

We require that you read and understand the contents of this manual completely (especially all safety information) before attempting any procedure contained herein. Extra copies of Owner/Operator Manuals can be purchased at your Snowex Dealer.



THIS SIGN SHOULD ALERT YOU:

The Society of Automotive Engineers has adopted this SAFETY ALERT SYMBOL to pinpoint characteristics that, if NOT carefully followed, can create a safety hazard. When you see this symbol in this manual or on the machine itself, BE ALERT! Your personal safety and the safety of others is involved.

Defined below are the SAFETY ALERT messages and how they will appear in this manual:



DANGER

(RED)

Information that, if not carefully followed, can cause death!



WARNING

(ORANGE)

Information that, if not carefully followed, can cause serious personal injury or death!



CAUTION

(YELLOW)

Information that, if not carefully followed, can cause minor injury or damage to equipment.

CONGRATULATIONS!

The spreader you have purchased is an example of snow and ice control technology at its finest! Your spreader's self-contained design is a trademark of all Snowex products. Here's why...

SIMPLICITY: Fewer moving parts manufactured of higher quality means minimal maintenance for your SnowEx spreader.

RELIABILITY: High impact linear low density polyethylene hopper, custom engineered powder coated frame and a custom engineered transmission found only on SnowEx products.

VERSATILITY: Multi-use capabilities allows spreading of a variety of materials for snow and ice control.

WARRANTY: Best in the industry, hands down! 2 years standard.

The benefits you are about to recognize are that of time, money and effort.
We welcome you to the world of Snowex Performance.



Before attempting any procedure in this book, these safety instructions must be read and understood by all workers who have any part in the preparation or use of this equipment.

For your safety, warning and information decals have been placed on this product to remind the operator of safety precautions. If anything happens to mark or destroy the decals, please request new ones from Snowex.



Remember, most accidents are preventable and caused by human error. Exercising of care and precautions must be observed to prevent the possibility of injury to operator or others!



Never operate equipment when under the influence of alcohol, drugs, or medication that might alter your judgment and/or reaction time.



Before working with the spreader, secure all loose fitting clothing and unrestrained hair.



Always wear safety glasses with side shields when working metal against metal. Failure to do this could result in serious injury to the eyes.



Never allow children to operate or climb on equipment.
Never weld or grind on equipment without having a fire extinguisher available.
Always check areas to be spread to be sure no hazardous conditions or substances are in the area. Always inspect unit for defects: broken, worn or bent parts, weakened areas on spreader.



Always make sure personnel are clear of areas of danger when using equipment.



Remember, it is the owner's responsibility to communicate information on safe usage and proper maintenance of all equipment.



CAUTION

Never use wet materials, or materials with foreign debris with any of these spreaders. These units are designed to handle dry, clean, free-flowing material.



CAUTION

Never leave material in hopper for long periods of time. Be aware that all ice melters are hygroscopic and will attract atmospheric moisture and harden up.



WARNING

Inspect the unit periodically for defects. Parts that are broken, missing, or worn out must be replaced immediately. The unit or any part of it can not be altered without prior written permission from the manufacturer.

Main Assembly Views

Model #SP-65 / SP-50



SP-50 Less Cover & Screen
(Not Shown)

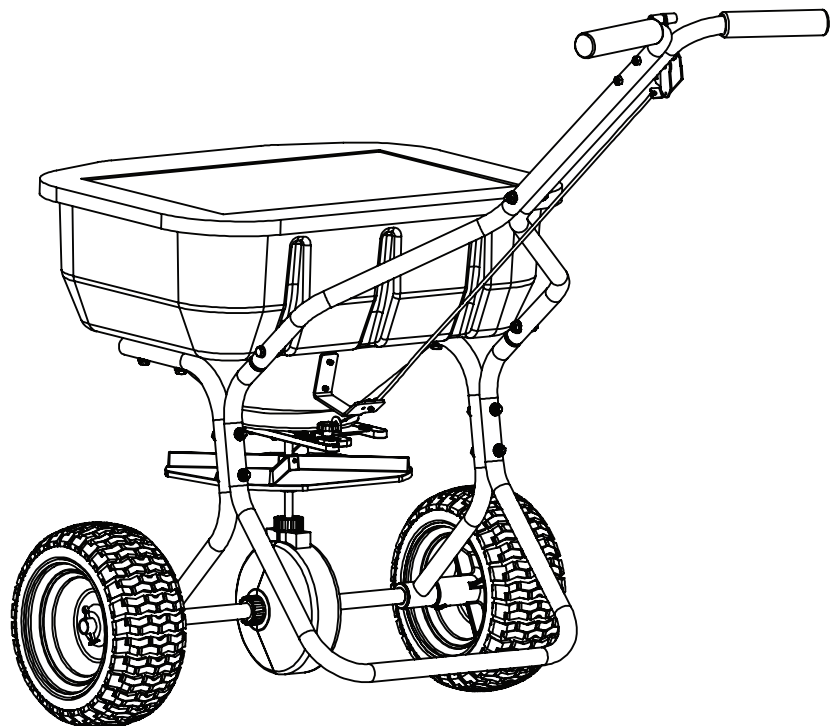

Sub-Assembly Parts Breakdown

Model #SP-65 / SP-50

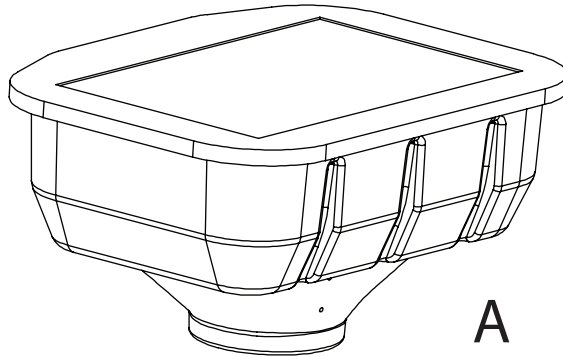

A

SP-50 Less Cover & Screen
(Not Shown)

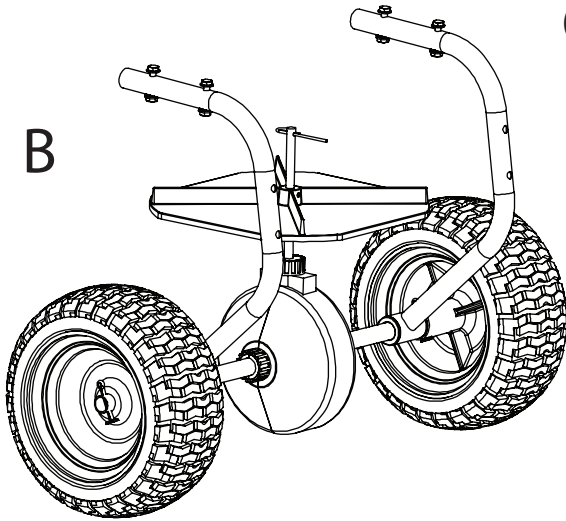

B

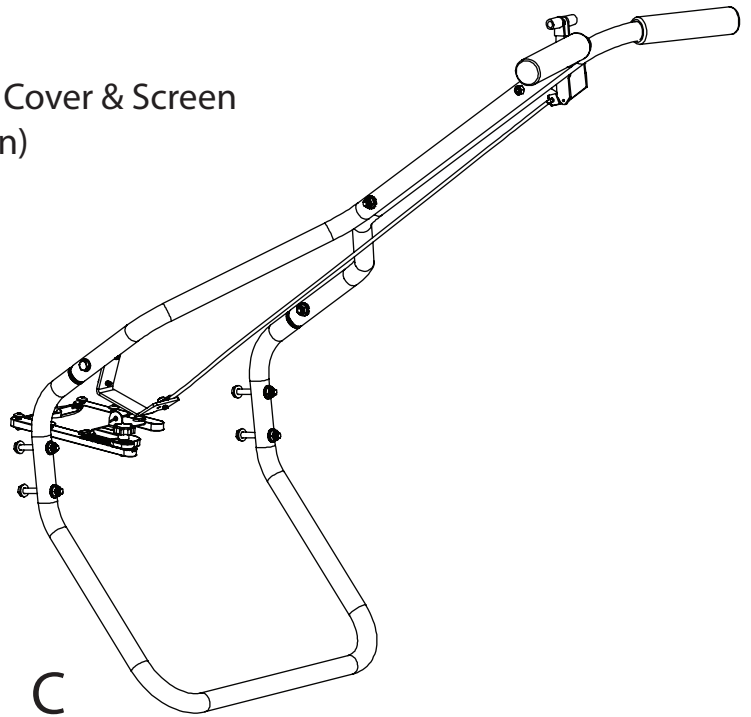

C

Key	Part No.	Description	Qty.
1	A	Hopper Assembly	1
2	B	Lower Axle Assembly	1
3	C	Upper Handle Gate Assembly	1

Complete Hopper Assembly Parts Breakdown

Model #SP65 / SP-50

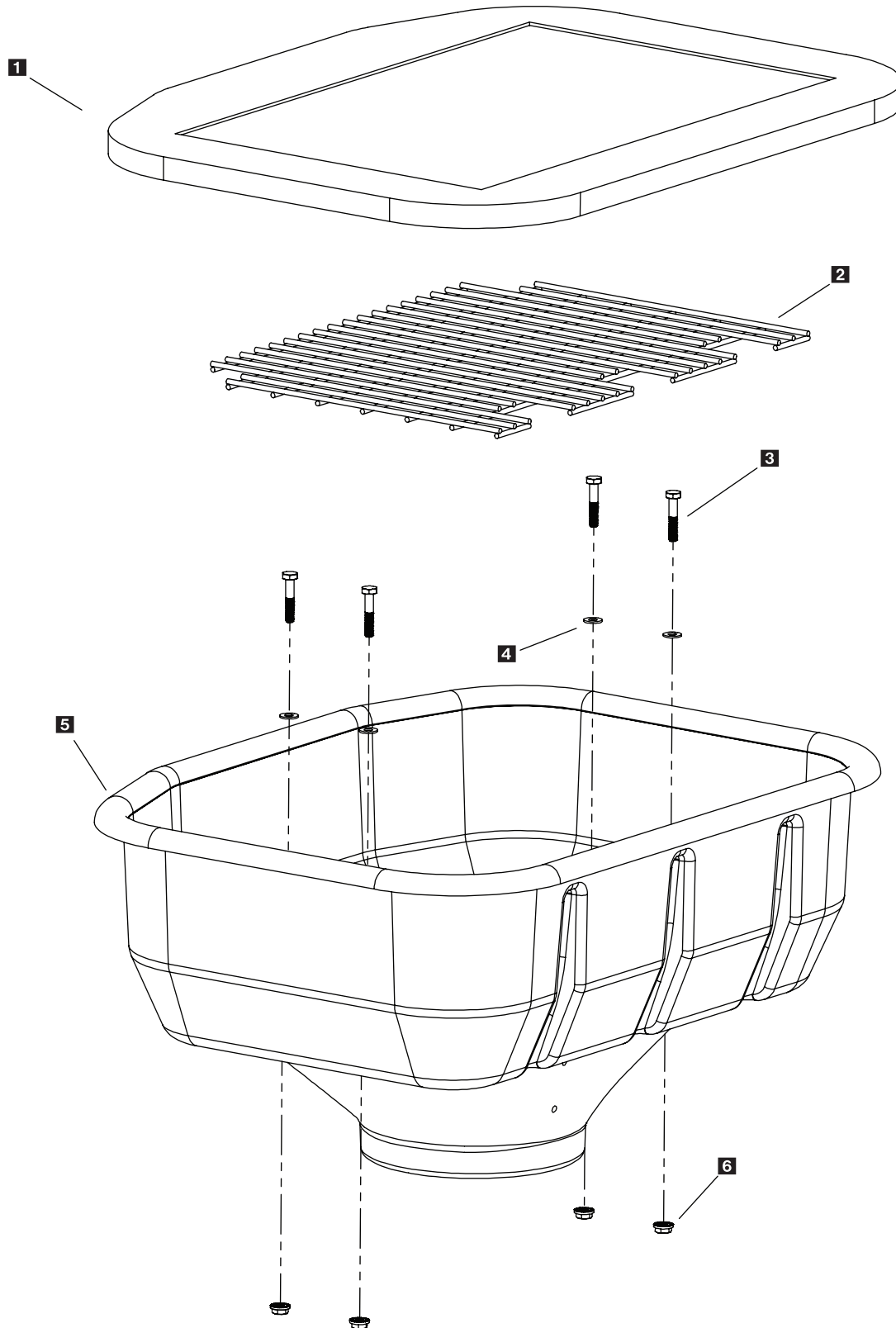

Hopper Assembly Parts Breakdown

Model #SP-65 / SP-50

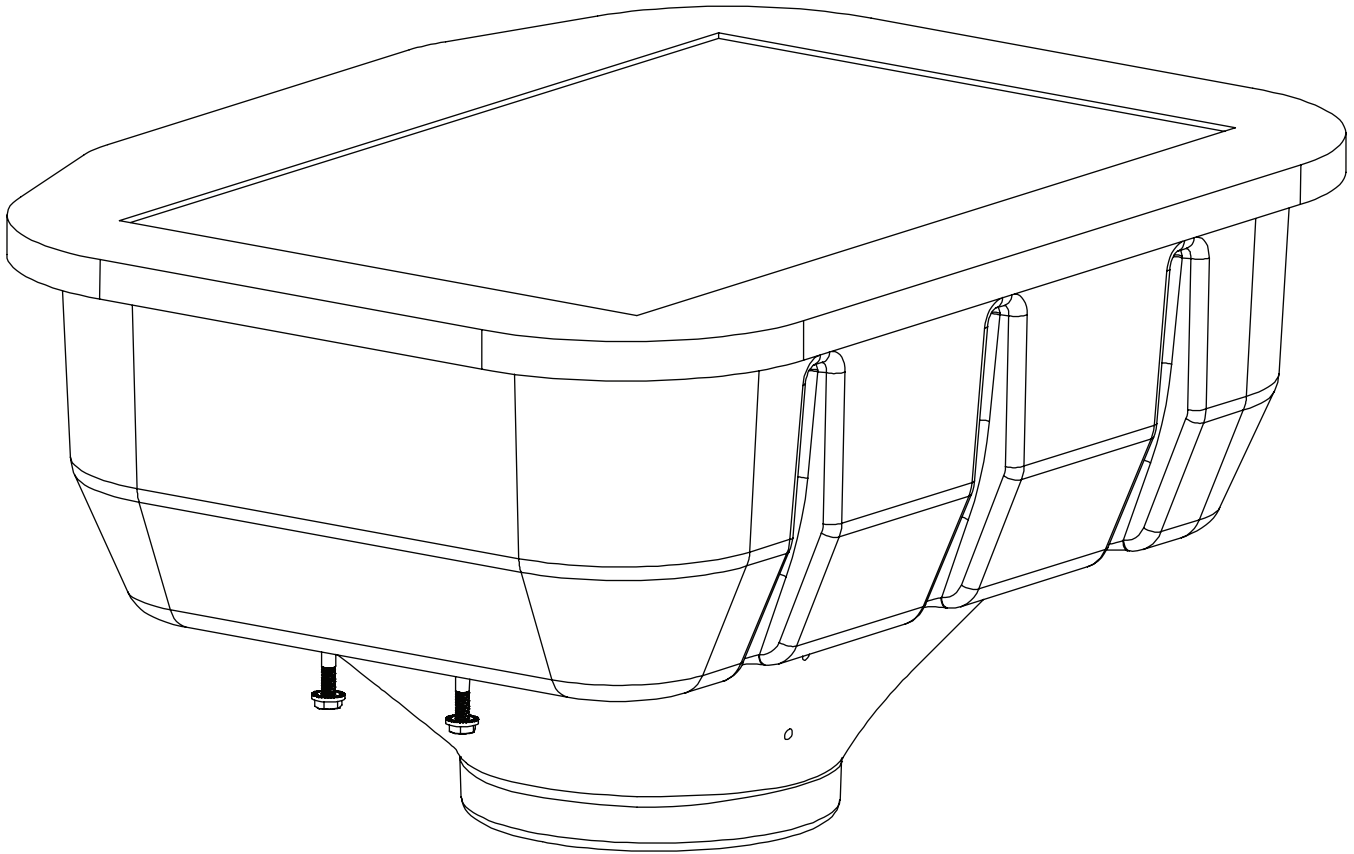

NOTE: SP-50 Less Items 1, 2

Key	Part No.	Description	Qty.
1	D 5967	Hopper Cover	1
2	D 5903	Screen	1
3	D 5969	1/4-20 x 1-3/8 HHCS	4
4	D 5701	1/4" Flat Washer Zinc	4
5	D 5981	Hopper	1
6	T 15133	1/4-20 Serrated Hex Flange Nut	4

Complete Axle Assembly Parts Breakdown

Model #SP-65 / SP-50

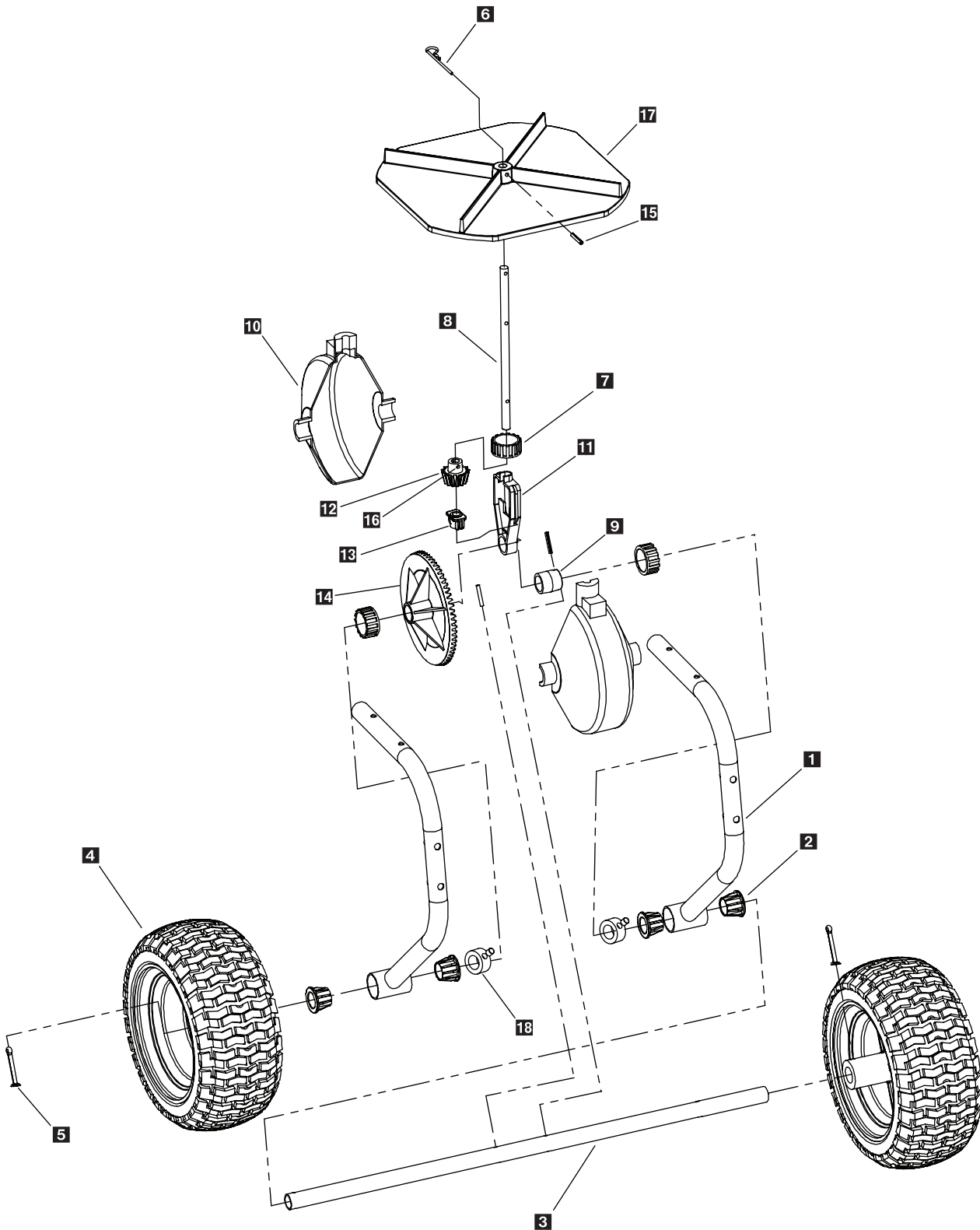

Complete Lower Axle Assembly Parts Breakdown



Model #SP-65 / SP-50

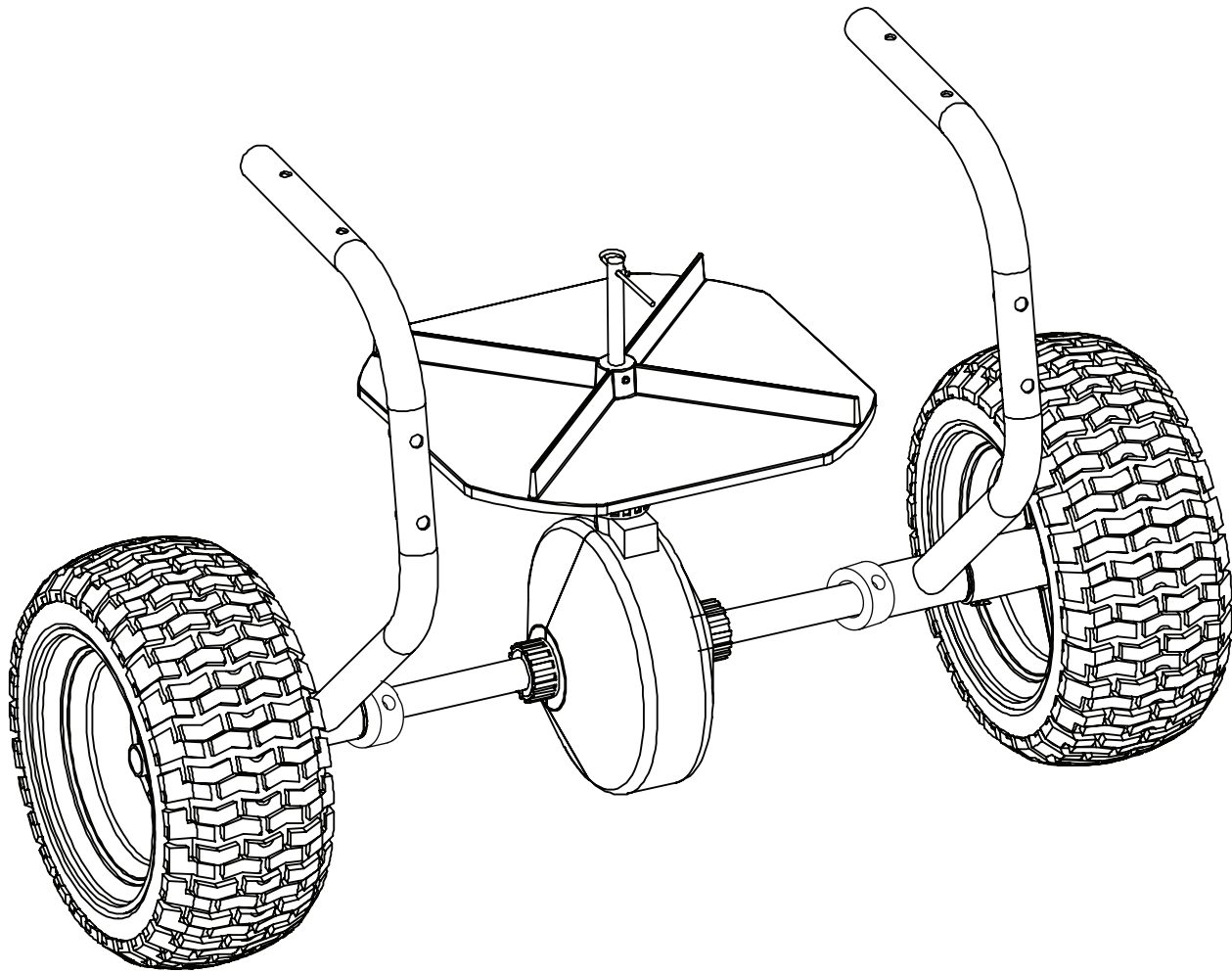

Key	Part No.	Description	Qty.
1	D 5977	Hopper Frame	1
2	D 5923	Axle Bushing	4
3	D 5972	Axle	1
4	D 5971	Wheel	2
5	D 5947	3/16 x 1-1/2" SS Cotter Pin	2
6	D 5922	Agitator Wire	1
7	D 5930	Lock Ring	3
8	D 5916	Spinner Shaft	1
9	D 5941	Axle Spacer	1
10	D 5911	Gear Cover	2
11	D 5913	Gear Support	1
12	D 5910	Pinion Gear	1
13	D 5926	Shaft Insert	1
14	D 5909	Drive Gear	1
15	D 5939	Spring Pin Spinner	1
16	D 5938	Spring Pin Pinion Gear	1
17	D 5902	Plastic Spinner	1
18	D 6024	Axle Collar	2

Complete Handle Assembly Parts Breakdown

Model #SP-65 / SP-50

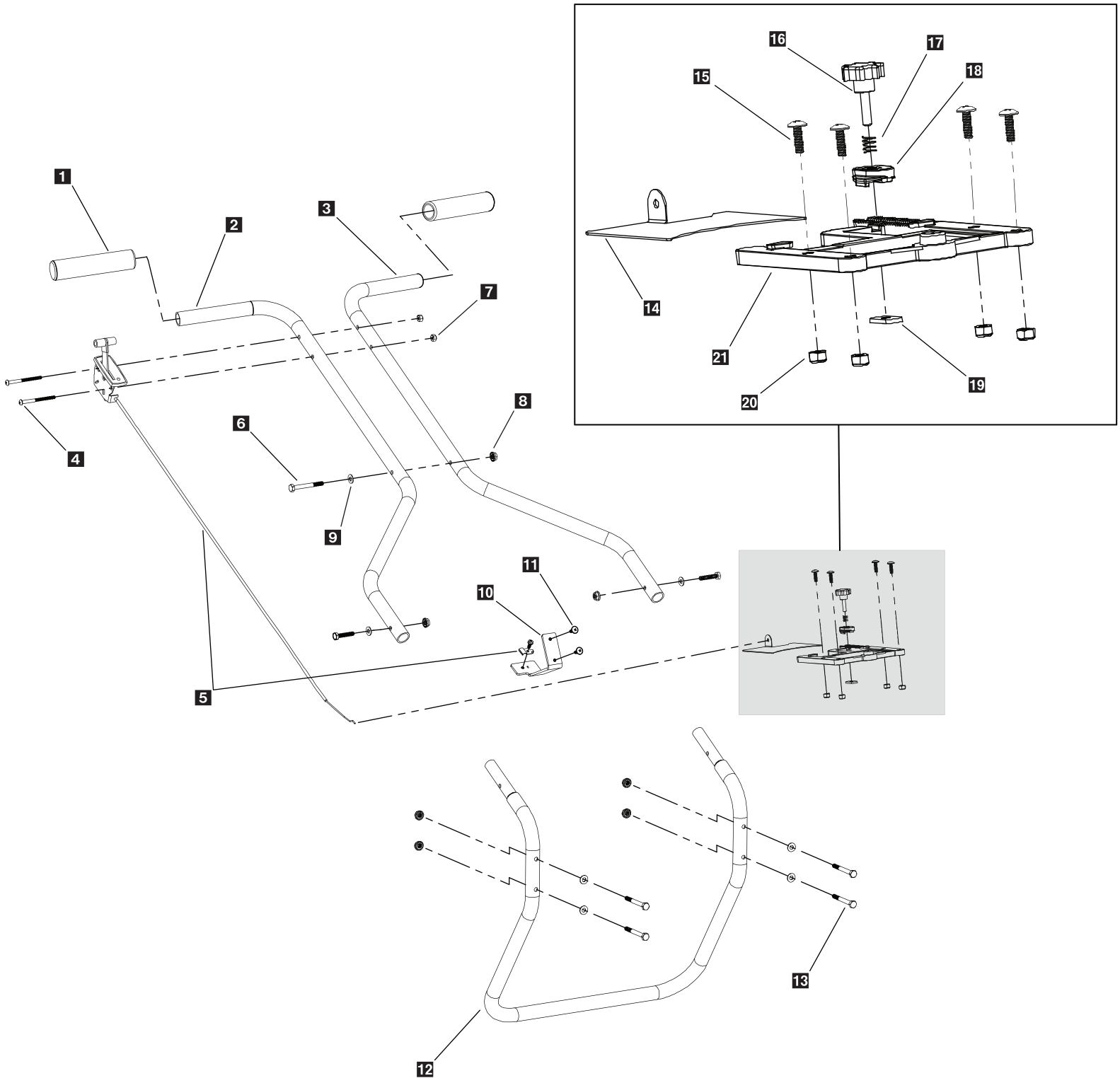

Complete Upper Handle Assembly Breakdown



Model #SP-65 / SP-50

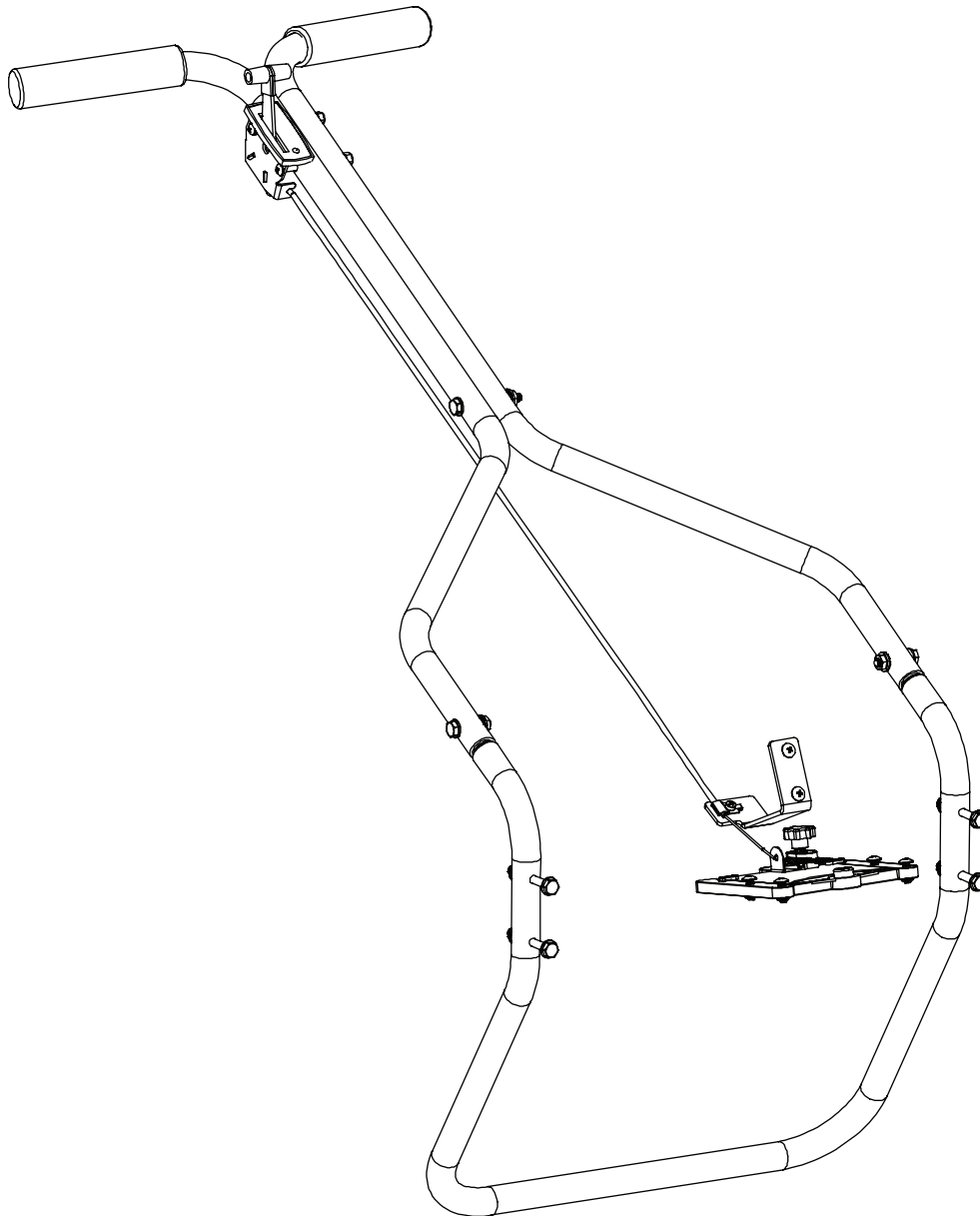

Key	Part No.	Description	Qty.	Key	Part No.	Description	Qty.
1	D 5917	Handle Grip	2	14	D 5914	Gate Slide	1
2	D 5975	Right Hand Upper Handle	1	15	D 5905	10/32 x 5/8 Truss Head Phillips	4
3	D 5976	Left Hand Upper Handle	1	16	D 5935	Locking Knob	1
4	D 5985	10/32 x 2-1/2 Round Head Phillips	2	17	D 5936	Adjustment Knob Spring	1
5	D 5983	Cable Control	1	18	D 5927	Gate Stop Block	1
6	D 5964	1/4-20 x 1-1/4 HHCS Zinc	2	19	D 5928	#10 Flat Nut	1
7	D 6158	10/32 Locknut	6	20	D 5948	10-32 Nylox Nut SS	6
8	T 15133	1/4-20 Serrated Flange Nut	11	21	D 5912	Gate Track	1
9	D 5701	1/4" Flat Washer	11				
10	D 5982	Cable Bracket	1				
11	D 5970	10/32 x 1/2 Phillips Truss Head	2				
12	D 5977	Frame Stand	1				
13	D 5987	1/4-20 x 2-1/4 HHCS	5				

Spreader Assembly Instructions



Model #SP-65 / SP-50

Step 1: Assemble Axle Assembly

- A) Slide shaft collars onto axle toward gear housing.
- B) Slide hopper frame onto axle through bushings.
- C) Assemble wheels to axle with long cotter key through drive wheel and the short cotter key outside free wheel through axle.
- D) Snug up axle collars to frame and tighten. Make sure axle spins freely.

Step 2: Assemble Hopper to Frame

- A) Insert spinner shaft through hole in bottom of hopper.
- B) Assemble hopper to frame with (4) bolts (NOTE: do not tighten).

Step 3: Assemble leg to hopper frame with (4) bolts (NOTE: do not tighten).

Step 4: Assemble Handle

- A) Assemble (2) Halves together with one bolt as shown.
- B) Assemble cable bracket to handle with (2) bolts through both halves and tighten.

Step 5: Assemble handle assembly to leg

- A) Slide handle onto leg and fasten with (2) bolts.

Step 6: Spin tires and make sure spreader is running smoothly.

Step 7: Tighten all bolts.

Step 8: Connect cable to gate.

Step 9: Tighten cable under cable clamp.

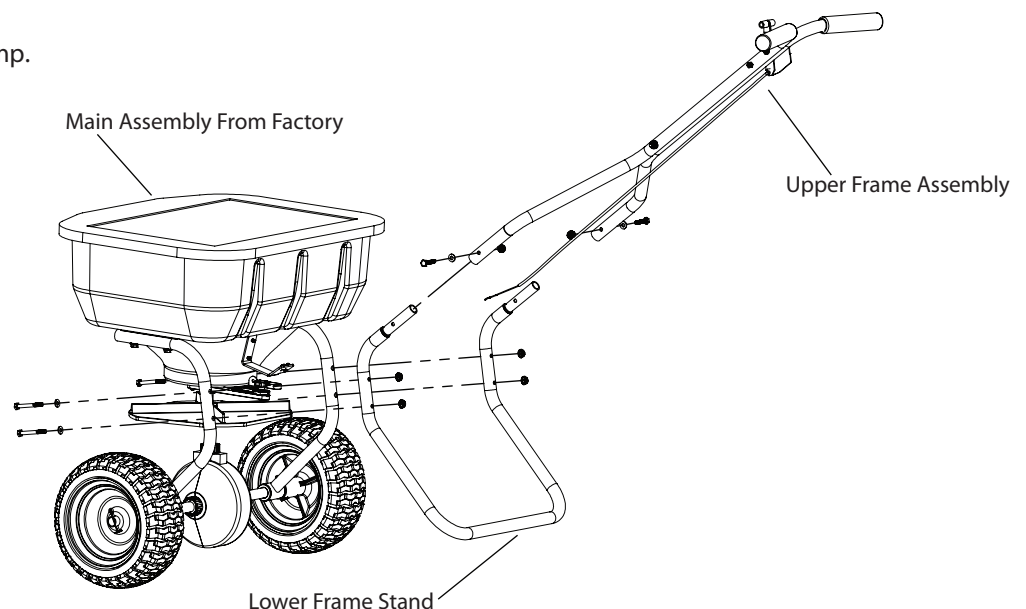

SPREADER LOADING

WARNING – Do not overload spreader. Use chart below to calculate weight of material. Weights of material are an average for dry materials

<u>Material</u>	<u>Weight Per Cubic Ft.</u>
Rock Salt	35-40 lbs.

- Warning– Never remove spreader from vehicle with material in it as this could cause damage to the frame assembly.
- Warning– Never leave materials in hopper for long periods of time as salt is hygroscopic and will attract atmospheric moisture and harden up.

SPREADING TIPS

- For a wider pass, increase walking pace.
- For a heavier pass, walk slower.
- Use care when operating spreader near pedestrians.
- Spread ice melters with the storm to prevent unmanageable levels of ice.
- Calculate spread pattern when near vegetation.

THIS PAGE INTENTIONALLY LEFT BLANK

Limited Warranty

Snowex products are warranted for a period of two years from the date of purchase against defects in material or workmanship under normal use and service, subject to limitations detailed below. Warranty period of two years begins on the date of purchase by the original retail user.

The WARRANTY REGISTRATION CARD must be returned to the manufacturer for this warranty to become effective. This warranty applies to the original retail purchaser only. This warranty does not cover damages caused by improper installation, misuse, lack of proper maintenance, alterations or repairs made by anyone other than authorized Snowex dealers or Snowex personnel. Due to the corrosive properties of the materials dispensed by spreaders, Trynex does not warrant against damage caused by corrosion. Warranty claims by the user must be made to the dealer from where the product was purchased, unless otherwise authorized by Snowex. Snowex reserves the right to determine if any part is defective and to repair or replace such parts as it elects. This warranty does not cover shipping costs of defective parts to or from the dealer.

LIMITATION OF LIABILITY

Neither Snowex, nor any company affiliated with it, makes any warranties, representations for promise as to the performance or quality other than what is herein contained. The liability of Snowex to the purchaser for damages arising out of the manufacture, sale, delivery, use or resale of this spreader shall be limited to and shall not exceed the costs of repair or replacement of defective parts. Snowex shall not be liable for loss of use, inconvenience or any other incidental, indirect or consequential damages, so the above limitations on incidental or consequential damages may not apply to you.

NO DEALER HAS AUTHORITY TO MAKE ANY REPRESENTATION OR PROMISE ON BEHALF OF SNOWEX, OR TO ALTER OR MODIFY THE TERMS OR LIMITATIONS OF THIS WARRANTY IN ANY WAY.

