

BASIC MECHANICS OF CALIFORNIA REAL ESTATE FINANCE

Amortization to Reg Z



Peter Rosenthal

TABLE OF CONTENTS

Introduction.....	3	
Mortgages vs. Trust Deeds.....	4	
Promissory Note (sample).....	5	
The Promissory Note.....		6
Usury.....		7
Deed of Trust (sample).....		8
The Trust Deed, Security for the Note.....		11
Deed of Reconveyance (sample).....		12
Note Amortization.....		13
Comparison of 15 and 30 year Fully Amortized Loan.....		14
Real Estate Math—Ugh!.....		15
The V.I.P. Handy Dandy Factor Table.....		17
Everyday Financing.....		19
ARM (Adjustable Rate Mortgages).....		19
Teaser Rates.....		19
Fixed vs. Variable.....		20
No Points, No Fees.....		20
15 Year vs. 30 Year.....		20
Bi-Weekly Mortgages.....		20
When to Refinance.....		20
Payment vs. Interest.....		21
First Half Review.....		22
Second Half Introduction.....		23
Underwater—Dealing with you Lender.....		24
Notice of Default (sample).....		25
The Notice of Default.....		27
Trustee’s Sale Guarantee (TSG) (sample).....		28
Notice of Trustee’s Sale (sample).....		38
Notice of Trustee’s Sale.....		40
Bankruptcy – The “B” Word.....		41
Trustee’s Sale – The Big Event.....		42
The Forty Thieves.....		44
Trustee’s Deed Upon Sale (sample).....		45
Life After Foreclosure.....		47
Bonus Section.....		48
Making Money with Foreclosure Properties.....		49
Sale Check List.....		50
Sources of Money for Buying Foreclosure Property.....		50
Glossary.....		a-d

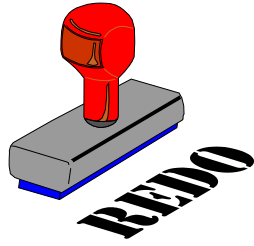

This publication is the first outline of the course being presented today. It is expected that this course and outline will change slightly from time to time and any suggestions or criticisms are encouraged.



Several of the following pages are intended as reference material and should be valuable real estate financing tools for future years to come.



Additional copies of this publication may be obtained by sending \$29.00* to the following address:

*includes shipping and handling

The V.I.P. Group
P.O. Box 26
Montrose, CA 91021-0026
Phone (818)248-0000 Fax (818)248-FAX6 (3296)
Email viptrustdeed@earthlink.net
or visit our web page at www.viploan.com

THE AUTHOR



Peter Rosenthal has held a real estate license since 1974 and has operated a related group of real estate companies since January, 1976. The V.I.P. group of companies handles all facets of real estate. Two of those companies, V.I.P. Trust Deed Company and Foothill Conveyance Corporation, specialize in first, second and third trust deed equity loans and the servicing and collection of trust deeds for outside beneficiaries.

Peter authored a real estate “question and answer” weekly newspaper column for 15 years in three local newspapers. He presently authors a monthly real estate article in Apartment Management magazine and frequently writes guest columns for a local Association of Realtors publication.

Peter taught real estate finance at Glendale College one night a week for five years and has been called on as a real estate expert witness in dozens of Superior Court cases for some 15 years.

Peter often lectures on trust deed and real estate fraud topics at various Realtor meetings.

INTRODUCTION



Do you own a house, condo, triplex, store or warehouse? Do you own 2-1/2 acres in Palmdale? If so, you are probably making payments on a note secured by a deed of trust. It doesn't matter if you are paying the previous seller, your uncle or Bank of America--the rules and documents are the same.

If you don't own real estate, are you planning to buy real estate? How about your relatives? Do you make payments on a real estate loan? If so, do you understand how it works or do you leave all that math up to the lender? You or someone you know will find this text invaluable as a financing workbook for future real estate investments or refinancing of present property.

Even if you are a practicing real estate salesperson or broker, I promise you a few shortcuts to everyday financing.

Now let's take a deep breath and begin a real estate financing journey.





MORTGAGES VS. TRUST DEEDS

Most eastern and midwest states use a mortgage. This is a two party instrument (mortgagee and mortgagor). Upon default a **judicial foreclosure** is initiated. This is a lengthy, expensive court procedure culminating in a sheriff's sale and usually allows the property owner one or two years to redeem the property after completion of the judicial foreclosure process.

Most western states, including California, have developed a far superior instrument--a promissory note secured by Deed of Trust. This allows for either a judicial (court) foreclosure similar to the mortgage foreclosure described above, or the far more common **non-judicial foreclosure**. A non-judicial foreclosure can be as short as three months and 21 days. This is quite inexpensive, does not involve attorneys or courts, and more importantly does not allow the Trustor any right to redeem the property after the property auction (Trustee's Sale).

The **generic** name for a real estate loan is a **mortgage**, and you will often see that word used in lieu of the more correct California term "trust deed." As an example, the common term ARM (adjustable rate mortgage) is used nationwide though actually a trust deed in many states.

Some types of notes secured by trust deeds allow for deficiency judgments. The lender obtains a deficiency judgment through a judicial foreclosure. If the sheriff's sale is for less than the amount owed, a "deficiency" exists and the lender is awarded a judgment for the shortfall. A deficiency judgment is NOT available if:

- The note is a purchase money obligation on a 1-4 unit owner occupied residential property
- A seller carry-back trust deed is involved A non-judicial foreclosure is completed.

Note

DO NOT DESTROY THIS NOTE: When paid, this note, with Deed of Trust securing same, must be surrendered to Trustee for cancellation, before reconveyance will be made.

NOTE SECURED BY DEED OF TRUST (Installment-interest only, due date, acceleration clause)

\$ 50,000.00 _____ Glendale _____, California _____ December 18, 1995 _____

In installments as herein stated, for value received, I promise to pay to V.I.P. TRUST DEED COMPANY, a
California corporation

or order, at place designated by Beneficiary
the sum of FIFTY THOUSAND AND 00/100 _____ dollars with interest from
January 23, 1996 on unpaid principal, at the rate of TWELVE AND ONE QUARTER (12.25%) _____ per cent
per annum; interest payable in installments of FIVE HUNDRED TEN AND .42/100 ---- (\$510.42)-----
dollars or more on the 23rd day of each calendar month, beginning on the 23rd day of February, 19 95
and continuing until the 23rd day of January, 19 98, on which day the unpaid balance of principal with
unpaid interest due thereon shall be due and payable.

ACCELERATION CLAUSE:

"If the Trustor shall convey or alienate said property, or any part thereof, or any interest therein, or shall be divested of his title in any manner or way, whether voluntary or involuntary any indebtedness or obligation secured hereby, irrespective of the maturity date expressed in any note evidencing the same, at the option of the holder hereof and without demand or notice shall become due and payable immediately."

PREPAYMENT PENALTY:

Borrower may prepay 20% of the principal balance in any calendar year without penalty. A penalty of six months additional interest will be charged on any principal payment in excess of aforesaid 20% allowance. No penalty after one year(s).

BREACH:

If a breach shall occur on this promissory note, the interest after the breach shall be the same as the interest on the face of the note. All sums extended by the Trustee, Beneficiary or Note Holder shall earn interest at the Note rate. IF THIS NOTE REMAINS UNPAID AT MATURITY, INTEREST SHALL ACCRUE AT 17.25% PER ANNUM.

Initial JB Initial MB

LATE FEE:

A late fee of Ten (10) % of monthly payment will be charged on any payment received more than 10 days after a due date.

Should default be made in payment of any installment when due, or in the performance of any provision or condition contained in the deed of trust securing this note, the whole sum of principal and interest shall become immediately due at the option of the holder of this note. Principal and interest payable in lawful money of the United States. If action be instituted on this note, I promise to pay such sum as the court may fix as attorney's fees and costs.

This note is subject to Section 2966 of the Civil Code, which provides that the holder of this note shall give written notice to the Trustor or his successor in interest, of prescribed information at least 90 and not more than 150 days before any balloon payment is due.

This note is secured by a Deed of Trust to Foothill Conveyance Corporation, a California Corporation as Trustee.

John Borrower
Borrower John Borrower

Mary Borrower
Borrower Mary Borrower

Borrower _____

Borrower _____

DO NOT DESTROY THIS NOTE

note.doc



THE NOTE

The promissory note is nothing other than an IOU. The note recites the following items and other details:

- Loan Amount
- Place
- Date
- Lender
- Borrower
- Interest starting date
- Interest rate
- Payment amount (if any)
- Payment period (monthly, semi-annually, etc.)
- Maturity date
- Late fees or other required terms
- Prepayment penalty
- Acceleration clauses
 - Alienation
 - Due on further encumbrance
 - Due on remarriage
 - Due on birthday
- Attorney's fees provision

This form can be used for a car loan, a student loan, a personal unsecured loan or a real estate loan

A promissory note used for real estate will also contain a sentence similar to: "This note is secured by a deed of trust to Foothill Conveyance Corporation." Unless the note is "secured" by real estate or personal property, the only way to collect upon default is to file a lawsuit in a court of law.



USURY

Prior to November 7, 1979, usury laws in California prohibited non-exempt lenders from lending money at higher than 10% interest. Private individuals are the largest groups of non-exempt lenders.

On November 7, 1979 the usury ceilings were changed. This much-needed change raised the then ten percent (10%) usury ceiling on many types of loans within the state.

Since then, the highest interest rate that can be charged by a non-exempt lender is the higher of *ten percent (10%)* or *“five percent (5%) above the Federal Discount Rate on the 25th day of the month preceding the transaction.”* For personal purposes, the ceiling is still 10% for a non-exempt lender. The common private party loan (friends) at 12%-18% is therefore usurious* and carries civil penalties and possibly criminal penalties unless the lender is exempt from this statute.

The Federal Discount Rate is not the Prime Rate or the Treasury Bill Rate, but is a rate charged by the Federal Reserve System to its member banks. This rate can be found in most financial periodicals or the Sunday finance section of most major California newspapers.

Many classes of California lenders are exempt from this regulation. These exempt lenders include the typical bank, savings bank, credit union, thrift, consumer finance lender (CFL), consumer mortgage lender (CML), finance company, etc. Real estate brokers are also exempt in lending their own funds or funds of others if acting in their brokerage capacity.

Private lenders are often jealous that a broker can charge (perhaps) 17% interest. I have sometimes heard the expression “you brokers are licensed to steal.” That may be true, but if so, the emphasis is on the word “LICENSED.” Private parties don’t understand or furnish the dozens of forms and disclosures required when making real estate loans. These forms and regulations include among others: state mortgage loan disclosure forms, federal truth in lending forms, including specifics of the annual percentage rate (APR), finance charge, amount financed, etc. In many cases the borrower has a 3 day or 5 day right to rescind the entire transaction at no cost. Non-exempt lenders are usually totally unaware of these regulations and are, frankly, a danger to themselves and innocent borrowers.

*As of January, 1998

Deed of Trust 1

RECORDING REQUESTED BY:

Chicago

96 124055

When Recorded, Mail To:

V.I.P. TRUST DEED CO.
P.O. BOX 26
MONTROSE, CA 91021-0026

RECORDED/FILED IN OFFICIAL RECORDS
RECORDER'S OFFICE
LOS ANGELES COUNTY
CALIFORNIA
10:01 AM JAN 23 1996

Escrow No. 13080 FST
Title Order No. 009521640-2

SPACE ABOVE THIS LINE FOR RECORDER'S USE

DEED OF TRUST AND ASSIGNMENT OF RENTS (ACCELERATION CLAUSE)

FEE \$20.00

BY THIS DEED OF TRUST, made this 18th day of December, 1995, between JOHN BORROWER and MARY BORROWER, Husband and Wife as Community Property

herein called Trustor, whose address is 10149 Commerce Avenue #28 Tujunga Ca 91042
(number and street) (city) (state) (zip)

and FOOTHILL CONVEYANCE CORPORATION, a California corporation, herein called Trustee, and

V.I.P. TRUST DEED COMPANY, a California corporation

hereinafter called Beneficiary, Trustor grants, transfers, and assigns to Trustee, in trust, with power of sale, that property in the City of Los Angeles Los Angeles County, California, described as:

AS PER EXHIBIT "A" ATTACHED HERETO AND MADE A PART HEREOF

Property Commonly Known as: 10149 Commerce Avenue #28., Tujunga, Ca 91042

If the Trustor shall convey or alienate said property or any part thereof or any interest therein or shall be divested of his title in any manner or way, whether voluntary or involuntary any indebtedness or obligation secured hereby, irrespective of the maturity date expressed in any note evidencing the same, at the option of the holder hereof and without demand or notice shall become due and payable immediately.

Trustor also assigns to Beneficiary all rents, issues and profits of said realty reserving the right to collect and use the same except during continuance of default hereunder and during continuance of such default authorizing Beneficiary to collect and enforce the same by any lawful means in the name of any party hereto.

For purpose of securing:

(1) Payment of the indebtedness evidenced by one promissory note in the principal sum of \$ 50,000.00 of even date herewith, payable to Beneficiary, and any extensions or renewals thereof; (2) the payment of any money that may be advanced by the Beneficiary to Trustor, or his successors, with interest thereon, evidenced by additional notes (indicating they are so secured) or by endorsement on the original note, executed by Trustor or his successor; (3) performance of each agreement of Trustor incorporated by reference or contained herein.

On June 14, 1985, identical fictitious Deeds of Trust were recorded in the offices of the County Recorders of the Counties of the State of

Deed of Trust p. 2

California, the first page thereof appearing as the following instrument numbers in the records of the respective County Recorder as follows:

COUNTY	Instrument Number	COUNTY	Instrument Number
Los Angeles	85-668576	Riverside	85-128546
San Bernardino	85-143016	Ventura	85-062101
Orange	85-216204	Imperial	125
San Diego*	85-210816		

*June 13, 1985

The provisions contained in Section A, including paragraphs 1 through 5, and the provisions contained in Section B, including paragraphs 1 through 9 of said fictitious Deeds of Trust are incorporated herein as fully as though set forth at length and in full herein.

The undersigned Trustor requests that a copy of any notice of default and any notice of sale hereunder be mailed to Trustor at the address hereinabove set forth, being the address designated for the purpose of receiving such notice.

John Borrower

 John Borrower

Mary Borrower

 Mary Borrower

STATE OF CALIFORNIA

COUNTY OF Los Angeles

SS

On January 15, 1996 before me,
Jane D. Notary personally
 appeared John Borrower and Mary Borrower

personally known to me OR proved to me on the basis of satisfactory evidence to be the person(s) whose name(s) is/are subscribed to the within instrument and acknowledged to me that he/she/they executed the same in his/her/their authorized capacity(ies), and that by his/her/their signature(s) on the instrument the person(s), or the entity upon behalf of which the person(s) acted, executed the instrument.

WITNESS my hand and official seal.

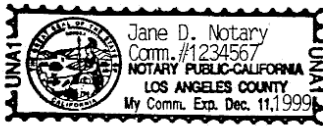

Signature *Jane D. Notary*

 Signature of Notary
 Jane D. Notary

96 124055

Page 2 of 2

exhibit A

EXHIBIT "A"

A CONDOMINIUM COMPRISED OF:

PARCEL 1:

(A) AN UNDIVIDED 1/28 INTEREST IN LOT 1 OF TRACT NO. 28294, IN THE CITY OF LOS ANGELES, COUNTY OF LOS ANGELES, STATE OF CALIFORNIA, AS PER MAP RECORDED IN BOOK 1023 PAGES 97 AND 98 OF MAPS, IN THE OFFICE OF THE COUNTY RECORDER OF SAID COUNTY.

EXCEPT UNITS 1 TO 28 INCLUSIVE AS SHOWN AND DEFINED ON THE CONDOMINIUM PLAN RECORDED AUGUST 10, 1984 AS INSTRUMENT NO. 84-960578 IN SAID OFFICE OF THE COUNTY RECORDER.

(B) UNIT 28, AS SHOWN AND DEFINED ON THE CONDOMINIUM PLAN REFERRED TO ABOVE.

96 124055

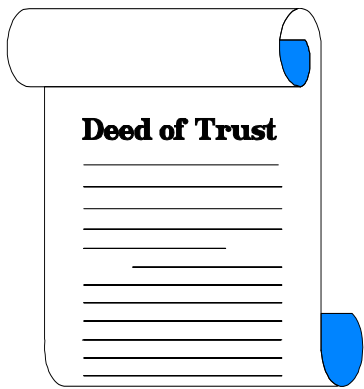

THE TRUST DEED -- SECURITY FOR THE NOTE

The trust deed is used as security for the note and is a three party instrument. For the balance of today we will refer to the

- Borrower as the **TRUSTOR**
- Lender as the **BENEFICIARY** or BENE
- The third party is the **TRUSTEE**, who actually holds title to the property, “in trust” for the Beneficiary. The Trustee is usually a title company or escrow company.

The correct way to state this is that the Trustor executes a Deed of Trust to the Trustee to hold in trust for the Beneficiary.

Also for the balance of the day, the term “trust deed” refers to a combination of a “Note Secured by a Deed of Trust.

The **Trustee** performs two basic functions:

1. Upon payment in full, the Beneficiary surrenders the Note and Trust Deed to the Trustee together with a “Request for Full Reconveyance.” The Trustee then records a **Deed of Reconveyance** which extinguishes the Trust Deed Lien of Record. **OR...**
2. Upon default by the Trustor, the Beneficiary notifies the Trustee and a “**Notice of Default**” is filed initiating the foreclosure process--more about that later.

The trust deed is recorded at the County Recorder’s Office in the county where the property is located. The trust deed may be a first, second, third, fourth or fifth trust deed or even an AITD (All Inclusive Deed of Trust). The priority is usually determined by the date of time of recording.

The following gives an example of trust deed priority:

995 Anywhere Street -- Property purchased 4/10/82 - all cash

- **1st trust deed recorded 8/14/85 \$110,000 Homeowner in favor of Bank of America**
- **2nd trust deed recorded 6/11/91 \$28,000 Homeowner in favor of XYZ Bank (home improvement)**
- **3rd trust deed recorded 10/12/93 \$15,000 Homeowner in favor of Blue Pool Company**

On 6/11/94 the 2nd trust deed comes due and the Trustor pays this off in cash. In this example, the \$15,000 third trust deed is now  a second trust deed.

Trust deed priority is similar to a movie line: each subsequent trust deed takes its place in line. The Beneficiary of a trust deed can voluntarily give up their place in line by agreeing to “subordinate” their position with a formal subordination agreement. As an example, the Blue Pool loan above could subordinate its position and allow a new first trust deed. This can be dangerous for the Beneficiary unless the new trust deed has the same or better terms than the trust deed being replaced, i.e. interest rate, term, payment, etc. **THINK OF SUBORDINATION AS A FOUR LETTER WORD.**

Deed of Reconveyance

RECORDING REQUESTED BY

97. 1898847

AND WHEN RECORDED MAIL TO:
Name John Borrower and
Mary Borrower
Street
Address 10149 Commerce Ave. #28
Tujunga, CA 91042
City & State

RECORDED/FILED IN OFFICIAL RECORDS
RECORDER'S OFFICE
LOS ANGELES COUNTY
CALIFORNIA
SEP 10 1997 AT 8 A.M.

FEE \$10 0
DAF \$2
r-20 2

SPACE ABOVE THIS LINE FOR RECORDER'S USE

DEED OF RECONVEYANCE

(Escrow No. 13080 FST)

WHEREAS, the indebtedness secured by the Deed of Trust EXECUTED BY JOHN BORROWER and MARY BORROWER, Husband and Wife as Community Property

TO Foothill Conveyance Corporation, a California Corporation, TRUSTEE(S)

dated December 18, 1995, and recorded as Instrument No. 96-124055 on January 23, 1996, in Book/Reel, Page/Image of Official Records in the Office of the County Recorder of Los Angeles County, State of California, has been paid.

NOW THEREFORE, the present Trustee(s) under said Deed of Trust do(es) hereby reconvey unto the parties entitled thereto all right, title and interest which was heretofore acquired by said Trustee(s) under said Deed of Trust, in the lands situate in the City of Los Angeles, County of Los Angeles, State of California, described as follows, to-wit:

Commonly known as: 10149 Commerce Avenue #28, Tujunga, CA 91042

FOOTHILL CONVEYANCE CORPORATION

Dated August 28, 1997

By: Peter Rosenthal, President

STATE OF CALIFORNIA

COUNTY OF LOS ANGELES

On August 28, 1997, before me, Jane D. Notary personally appeared Peter Rosenthal

personally known to me -OR- proved to me on the basis of satisfactory evidence to

be the person(s) whose name(s) is/are subscribed to the within instrument and acknowledged to me that he/she/they executed the same in his/her/their authorized capacity(ies), and that by his/her/their signature(s) on the instrument the person(s), or the entity upon behalf of which the person(s) acted, executed the instrument.

WITNESS my hand and official seal.

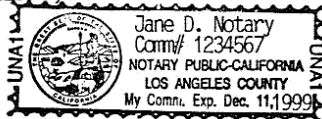

Signature Jane D. Notary
Signature of Notary Jane D. Notary

recon.jc

NOTE AMORTIZATION

AMORTIZATION: A fixed periodic payment amount that will usually fully retire the obligation over the term of the loan. As an illustration, we will take a \$25,000 loan at 8% interest with monthly payments and a term of one year. The only difference between these four examples is the amount of the monthly payment. The first example is the typical home loan (fully amortized), although the typical 30 year term has been drastically shortened.

EXAMPLE 1: A **FULLY AMORTIZED** loan will result in no balance remaining at the end of the loan, i.e. “until paid.”

EXAMPLE 2: A **PARTIALLY AMORTIZED** loan will result in a periodic principal reduction but still have a principal balance remaining at maturity.

EXAMPLE 3: An **INTEREST ONLY** note has a periodic payment that equals the interest charge for the period and the original principal balance is still due at maturity.

EXAMPLE 4: **NEGATIVE AMORTIZATION** refers to a note with periodic payments of less than interest only. This type of note will have an increased principal balance after every payment.

EXAMPLE \$25,000 - 8% - 1 year

1. Fully amortized: Payment \$2,174.71
2. Partially amortized: Payment \$1,500.00
3. Interest only: Payment \$166.67
4. Negative amortization: Payment \$150.00

“**PAY MORE**” -- the two word secret to taking over total control of the life of your loan. As you will now see, with these two words you have the power to

- Convert a negative amortization loan to an “interest only” loan.
- Convert an interest only loan to a partially amortized loan.
- Convert a partially amortized loan to a fully amortized loan.
- Convert a 30 year loan to a 15 year loan...etc.

COMPARISON OF 15 AND 30 YEAR FIXED RATE LOANS

30 YEAR LOAN

Amount of loan	\$182,500.00
Interest rate	7.5%
Term of loan (months)	360
Amount to amortize	\$1,276.06
Desired payment	\$1,276.06
Balloon payment	\$1,282.35
Total payments	<u>\$459,387.90</u>
Total interest	\$276,887.90
Finance charges	\$276,887.90
Amount financed	\$182,500.00
APR	7.5%

15 YEAR LOAN

Amount of loan	\$182,500.00
Interest rate	7.5%
Term of loan (months)	180
Amount to amortize	\$1,691.79
Desired payment	\$1,691.79
Balloon payment	\$1,693.82
Total payments	<u>\$304,524.20</u>
Total interest	\$122,024.20
Finance charges	\$122,024.20
Amount financed	\$182,500.00
APR	7.5%

Interest 30 year	\$276,887.90
Interest 15 year	<u>\$122,024.20</u>
Interest saved	\$154,863.70



REAL ESTATE MATH - UGH!

The following three examples match those shown on Page 13. We will do the simple math for each note. All examples are \$25,000 @ 8% with monthly payments. The only difference is the amount of payment. (Most real estate payments are paid in ARREARS; rent is paid in ADVANCE.)

FULLY AMORTIZED

Beginning balance \$25,000 - monthly payment \$2,174.71

1. \$25,000 (principal) X 8% (interest) = \$2,000 (interest for one year)
2. \$2,000 (interest for one year) divided by 12 = \$166.67 interest for the first month.. Place this in interest column for the first month
3. Now take \$2,174.71 (monthly payment) minus \$166.67 interest charge = \$2,008.04 = this month's principal reduction.
4. Now take \$25,000 (beginning balance) minus \$2,008.04 principal reduction = \$22,991.96 remaining balance.

	Interest	Principal	Remaining Balance
Payment #1	\$166.67	\$2,008.04	\$22,991.96

Was that too tough? Now let's do the second month's payment. Same steps.

1. \$22,991.96 (remaining principal balance after Payment #1) X 8% = \$1,839.36 (interest for one year)
2. Take \$1,839.36 (interest for one year), divide by 12 = \$153.28 interest for second month
3. Take \$2,174.71 monthly payment minus \$153.28 interest charge = \$2,021.43 = this month's principal reduction.
4. Take \$22,991.96 (remaining balance after first payment) minus \$2,021.43 principal reduction = \$20,970.53 remaining balance after second payment.

	Interest	Principal	Remaining Balance
Payment #2	\$153.28	\$2,021.43	\$20,970.53

Same steps again for the third payment, and so on until paid in full.

	Interest	Principal	Remaining Balance
Payment #3	\$139.80	\$2,034.91	\$18,935.62
Payment #4	\$126.24	\$2,048.47	\$16,887.15
Payment #5	\$112.58	\$2,062.13	\$14,825.02
Payment #6	\$98.83	\$2,075.88	\$12,749.14
Payment #7	\$84.99	\$2,089.72	\$10,659.42
Payment #8	\$71.06	\$2,103.65	\$8,555.77
Payment #9	\$57.04	\$2,117.67	\$6,438.10
Payment #10	\$42.92	\$2,131.79	\$4,306.31
Payment #11	\$28.71	\$2,146.00	\$2,160.31
Payment #12	\$14.40	\$2,160.31	-0-

PARTIALLY AMORTIZED

Beginning balance \$25,000 - monthly payment \$1,500.00

1. Steps 1 and 2 same as before
2. Take \$1,500.00 monthly payment minus \$166.67 interest charge = \$1,333.33 = this month's principal reduction.
3. Now take \$25,000 (beginning balance) minus \$1,333.33 = \$23,666.67 remaining balance.
4. Same procedure for payments #2 and #3:

	Interest	Principal	Remaining Balance
Payment #1	\$166.67	\$1,333.33	\$23,666.67
Payment #2	\$157.78	\$1,342.22	\$22,324.45
Payment #3	\$148.83	\$1,351.17	\$20,973.28
Payment #11	\$ 75.06	\$1,424.94	\$ 9,834.54

INTEREST ONLY

Monthly payment \$166.67

With an interest only loan, the monthly interest, principal reduction and the remaining balance will remain constant. Again, follow steps 1 and 2. The remaining balance will be \$25,000.00 after each payment and there will be a balloon payment at maturity of \$25,000.00.

	Interest	Principal	Remaining Balance
Payment #1	\$166.67	\$-0-	\$25,000.00
Payment #2	\$166.67	\$-0-	\$25,000.00
Payment #3	\$166.67	\$-0-	\$25,000.00

NEGATIVE AMORTIZATION

Monthly payment \$150.00

1. Steps 1 and 2 same as in "Fully Amortized" section .

Take \$150.00 monthly payment, subtract the interest charge (\$166.67) and record the negative amount in the principal column. This negative will then be **added** to the balance of the loan and future interest due will **increase** accordingly.

	Interest	Principal	Remaining Balance
Payment #1	\$166.67	-\$16.67	\$25,016.67
Payment #2	\$166.78	-\$16.78	\$25,033.45
Payment #3	\$166.89	-\$16.89	\$25,050.34
Payment #11	\$167.81	-\$17.81	\$25,189.57

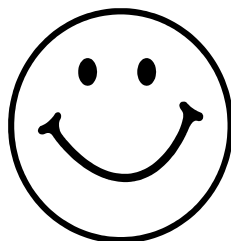

Factor table p. 1

THE V.I.P. HANDY DANDY FACTOR TABLE								
<p>This table will help you easily calculate a fully amortized monthly payment. To use, simply find the appropriate factor for the interest rate and number of years of your loan. As an example, the factor for a 30 year 9% loan is .0080462. Multiply the factor by the loan amount to calculate your monthly payment. Therefore, a 9% 30 year fully amortized loan payment can easily be figured as follows: The factor (.0080462) times loan amount (hypothetical \$182,500) equals monthly payment, i.e. \$1,468.43. That's right, you can now calculate thousands of payments with ONE multiplication.</p>								
YEARS	INTEREST RATE							
	4.00	4.25	4.50	4.75	5.00	5.25	5.50	5.75
1	.0851499	.0852642	.0853785	.0854930	.0856075	.0857221	.0858368	.0859516
2	.0434249	.0435363	.0436478	.0437595	.0438714	.0439834	.0440957	.0442080
3	.0295240	.0296353	.0297469	.0298588	.0299709	.0300833	.0301959	.0303088
5	.0184165	.0185296	.0186430	.0187569	.0188712	.0189860	.0191012	.0192168
7	.0136688	.0137842	.0139002	.0140167	.0141339	.0142517	.0143700	.0144890
10	.0101245	.0102438	.0103638	.0104848	.0106066	.0107292	.0108526	.0109769
15	.0073969	.0075228	.0076499	.0077783	.0079079	.0080388	.0081708	.0083041
20	.0060598	.0061923	.0063265	.0064622	.0065996	.0067384	.0068789	.0070208
25	.0052784	.0054174	.0055583	.0057012	.0058459	.0059925	.0061409	.0062911
30	.0047742	.0049194	.0050669	.0052165	.0053682	.0055220	.0056779	.0058357
35	.0044277	.0045789	.0047326	.0048886	.0050469	.0052074	.0053702	.0055350
40	.0041794	.0043362	.0044956	.0046576	.0048220	.0049887	.0051577	.0053289
	6.00	6.25	6.50	6.75	7.00	7.25	7.50	7.75
1	.0860664	.0861814	.0862964	.0864115	.0865267	.0866420	.0867574	.0868729
2	.0443206	.0444333	.0445463	.0446593	.0447726	.0448860	.0449996	.0451134
3	.0304219	.0305353	.0306490	.0307629	.0308771	.0309915	.0311062	.0312212
5	.0193328	.0194493	.0195661	.0196835	.0198012	.0199194	.0200379	.0201570
7	.0146086	.0147287	.0148494	.0149708	.0150927	.0152152	.0153383	.0154620
10	.0111021	.0112280	.0113548	.0114824	.0116108	.0117401	.0118702	.0120011
15	.0084386	.0085742	.0087111	.0088491	.0089883	.0091286	.0092701	.0094128
20	.0071643	.0073093	.0074557	.0076036	.0077530	.0079038	.0080559	.0082095
25	.0064430	.0065967	.0067521	.0069091	.0070678	.0072281	.0073899	.0075533
30	.0059955	.0061572	.0063207	.0064860	.0066530	.0068218	.0069921	.0071641
35	.0057019	.0058708	.0060415	.0062142	.0063886	.0065647	.0067424	.0069218
40	.0055021	.0056774	.0058546	.0060336	.0062143	.0063967	.0065807	.0067662
	8.00	8.25	8.50	8.75	9.00	9.25	9.50	9.75
1	.0869884	.0871041	.0872198	.0873356	.0874515	.0875675	.0876835	.0877997
2	.0452273	.0453414	.0454557	.0455701	.0456847	.0457995	.0459145	.0460296
3	.0313364	.0314518	.0315675	.0316835	.0317997	.0319162	.0320329	.0321499
5	.0202764	.0203963	.0205165	.0206372	.0207584	.0208799	.0210019	.0211242
7	.0155862	.0157111	.0158365	.0159625	.0160891	.0162162	.0163440	.0164723
10	.0121328	.0122653	.0123986	.0125327	.0126676	.0128033	.0129398	.0130770
15	.0095565	.0097014	.0098474	.0099945	.0101427	.0102919	.0104422	.0105936
20	.0083644	.0085207	.0086782	.0088371	.0089973	.0091587	.0093213	.0094852
25	.0077182	.0078845	.0080523	.0082214	.0083920	.0085638	.0087370	.0089114
30	.0073376	.0075127	.0076891	.0078670	.0080462	.0082268	.0084085	.0085915
35	.0071026	.0072849	.0074686	.0076536	.0078399	.0080274	.0082161	.0084059
40	.0069531	.0071414	.0073309	.0075217	.0077136	.0079066	.0081006	.0082956

Factor table p. 2

YEARS	INTEREST RATE							
	10.00	10.25	10.50	10.75	11.00	11.25	11.50	11.75
1	.0879159	.0880322	.0881486	.0882651	.0883817	.0884983	.0886151	.0887319
2	.0461449	.0462604	.0463760	.0464919	.0466078	.0467240	.0468403	.0469568
3	.0322672	.0323847	.0325024	.0326205	.0327387	.0328572	.0329760	.0330950
5	.0212470	.0213703	.0214939	.0216180	.0217424	.0218673	.0219926	.0221183
7	.0166012	.0167306	.0168607	.0169913	.0171224	.0172542	.0173865	.0175193
10	.0132151	.0133539	.0134935	.0136339	.0137750	.0139169	.0140595	.0142029
15	.0107461	.0108995	.0110540	.0112095	.0113660	.0115234	.0116819	.0118413
20	.0096502	.0098164	.0099838	.0101523	.0103219	.0104926	.0106643	.0108371
25	.0090870	.0092638	.0094418	.0096209	.0098011	.0099824	.0101647	.0103480
30	.0087757	.0089610	.0091474	.0093348	.0095232	.0097126	.0099029	.0100941
35	.0085967	.0087886	.0089813	.0091750	.0093696	.0095649	.0097611	.0099579
40	.0084915	.0086882	.0088857	.0090840	.0092829	.0094826	.0096828	.0098836
	12.00	12.25	12.50	12.75	13.00	13.25	13.50	13.75
1	.0888488	.0889658	.0890829	.0892000	.0893173	.0894346	.0895520	.0896695
2	.0470735	.0471903	.0473073	.0474245	.0475418	.0476593	.0477770	.0478949
3	.0332143	.0333338	.0334536	.0335737	.0336940	.0338145	.0339353	.0340563
5	.0222444	.0223710	.0224979	.0226253	.0227531	.0228813	.0230098	.0231388
7	.0176527	.0177867	.0179212	.0180563	.0181920	.0183282	.0184649	.0186022
10	.0143471	.0144920	.0146376	.0147840	.0149311	.0150789	.0152274	.0153767
15	.0120017	.0121630	.0123252	.0124884	.0126524	.0128174	.0129832	.0131499
20	.0110109	.0111856	.0113614	.0115381	.0117158	.0118943	.0120737	.0122541
25	.0105322	.0107174	.0109035	.0110905	.0112784	.0114670	.0116564	.0118467
30	.0102861	.0104790	.0106726	.0108669	.0110620	.0112577	.0114541	.0116511
35	.0101555	.0103537	.0105525	.0107520	.0109519	.0111524	.0113534	.0115549
40	.0100850	.0102869	.0104892	.0106920	.0108951	.0110987	.0113026	.0115069
	14.00	14.25	14.50	14.75	15.00	16.00	17.00	18.00
1	.0897871	.0899048	.0900225	.0901404	.0902583	.0907309	.0912048	.0916800
2	.0480129	.0481311	.0482494	.0483680	.0484866	.0489631	.0494423	.0499241
3	.0341776	.0342992	.0344210	.0345430	.0346653	.0351570	.0356527	.0361524
5	.0232683	.0233981	.0235283	.0236589	.0237899	.0243181	.0248526	.0253934
7	.0187400	.0188784	.0190173	.0191568	.0192968	.0198621	.0204358	.0210178
10	.0155266	.0156773	.0158287	.0159807	.0161335	.0167513	.0173798	.0180185
15	.0133174	.0134858	.0136550	.0138250	.0139959	.0146870	.0153900	.0161042
20	.0124352	.0126172	.0128000	.0129836	.0131679	.0139126	.0146680	.0154331
25	.0120376	.0122293	.0124216	.0126146	.0128083	.0135889	.0143780	.0151743
30	.0118487	.0120469	.0122456	.0124448	.0126444	.0134476	.0142568	.0150709
35	.0117567	.0119590	.0121617	.0123647	.0125681	.0133847	.0142053	.0150289
40	.0117114	.0119162	.0121213	.0123267	.0125322	.0133565	.0141832	.0150118
	19.00	20.00	21.00	22.00	23.00	24.00	25.00	26.00
1	.0879159	.0880322	.0881486	.0882651	.0883817	.0884983	.0886151	.0887319
2	.0461449	.0462604	.0463760	.0464919	.0466078	.0467240	.0468403	.0469568
3	.0322672	.0323847	.0325024	.0326205	.0327387	.0328572	.0329760	.0330950
5	.0212470	.0213703	.0214939	.0216180	.0217424	.0218673	.0219926	.0221183
7	.0166012	.0167306	.0168607	.0169913	.0171224	.0172542	.0173865	.0175193
10	.0132151	.0133539	.0134935	.0136339	.0137750	.0139169	.0140595	.0142029
15	.0107461	.0108995	.0110540	.0112095	.0113660	.0115234	.0116819	.0118413
20	.0096502	.0098164	.0099838	.0101523	.0103219	.0104926	.0106643	.0108371
25	.0090870	.0092638	.0094418	.0096209	.0098011	.0099824	.0101647	.0103480
30	.0087757	.0089610	.0091474	.0093348	.0095232	.0097126	.0099029	.0100941
35	.0085967	.0087886	.0089813	.0091750	.0093696	.0095649	.0097611	.0099579
40	.0084915	.0086882	.0088857	.0090840	.0092829	.0094826	.0096828	.0098836

EVERYDAY FINANCING

Now that we have passed through the “UGH” phase, let’s explore your actual financing or refinancing options.

ADJUSTABLE RATE MORTGAGES (ARMs)

This loan’s interest and payment adjusts at fixed intervals (monthly, semi-annually or yearly) based on an index and a fixed spread or margin. There really is no mystery here. Various margins are used by lenders. The most common are TREASURY BILL INDEX, LONDON INTER-BANK OFFERING RATE (LIBOR), PRIME RATE or the 11TH DISTRICT COST OF FUNDS. Historically the 11th District has proved to be the least volatile margin and the most widely used. Here’s how this works:

7/95	11th District Cost of Funds	5.14%
	Fixed margin	<u>2.25%</u>
	Rate charged or TRUE RATE	7.39%
7/96	11th District Cost of Funds	4.82%
	Fixed margin	<u>2.25%</u>
	Rate charged or TRUE RATE	7.07%
7/97	11th District Cost of Funds	4.86%
	Fixed margin	<u>2.25%</u>
	Rate charged or TRUE RATE	7.11%

The interest rate simply moves up or down at each interval, based on this simple formula.

TEASER RATES

A teaser, or initial rate, is simply a rate that is artificially low to lure you into the loan. Unwary borrowers usually concentrate on the initial low interest and initial low payment. “Tomorrow is another day.” Teaser rates were first used to lure borrowers away from fixed rate loans. Also, it was easier to qualify a borrower with a lower initial payment. Even lenders believed “tomorrow is another day.” The theoretical concept is that borrowers will get raises in the future to help pay for payment increases.

When teasers were first introduced I used to call them “sucker rates.” In my newspaper articles in the late 1970’s I used to offer (tongue in cheek) teaser rates of 4%. In those days fixed rates may have been 9% and teaser variable rates at 7%. I would offer 4% and would then claim, “Don’t worry, the loan can only go up one tenth of one percent per period--every hour.”

REMEMBER, LIARS CAN FIGURE AND FIGURES CAN LIE.

Teaser rates really do have a legitimate place in real estate financing, however. If you plan to fix up the property and resell in 1-2 years or more, simple math may show that a teaser with semi-annual or annual adjustments is the way to go--**At least be aware.**

FIXED VS. VARIABLE

Many factors are involved here, but the most obvious is time. How long do you plan to own the property? I am conservative and have never considered anything other than a fixed rate loan for my home and I have now lived in it for over 20 years. I have refinanced twice.

Though adjustable rate loans have lifetime caps, that cap will always be higher than the fixed rate loan. Perhaps you like roller coaster rides--Take out your crystal ball and take your best guess at future interest rates.

NO POINTS, NO FEES

Do you really believe in the tooth fairy? This gimmick is “the teaser rate of the ‘90’s.” *Obviously* the interest rate on a no fee loan will be higher than a loan with a one point loan fee and closing costs. Calculate this like a teaser rate. If you are going to sell the property in a year or two this may be a good idea. This is obviously a disaster over 15-30 years.

15 YEAR FIXED VS. 30 YEAR FIXED

Use your “Handy Dandy Tables” to calculate the difference in these two payments on the loan you will apply for. Often the interest rate offered on a 15 year loan will be 1/4% to 1/2% lower than a 30 year loan. If you are SURE you can afford this, GO FOR IT.

I have a 15 year 7% fixed rate loan on my home. Be aware, however, that the payment is higher and a partial loss of income may get you in trouble. If you are not 100% sure, take the 30 year lower payment and use the two magic words: **PAY MORE** when you can.

THE BI-WEEKLY PAYMENT GIMMICK

“Pay me a \$400 set up fee and I’ll show you how to save \$10,000 to \$100,000 in interest on your loan and with magic, pay off your loan in 18 instead of 30 years. If your payment is normally \$1,000 per month you pay \$500 every two weeks and this really works like magic.” It does, but there is no magic: We have already covered this, i.e. **PAY MORE**.



\$1,000 per month = yearly payments of \$12,000

\$500 every two weeks = \$500 X 26 (52 weeks in one year) = \$13,000

This is simply a cute way of coaxing one extra payment per year. Do you really need to pay \$400 for the privilege? Take that \$400 and pay it to the lender next month--MAGIC! Then **PAY MORE** whenever you can.

WHEN TO REFINANCE

This is a very common problem for those of us who own real estate. This is also a very simple math problem--It’s no big deal. One simple guide is “2 and 2.” If the new rate offered today is 2% less than your existing rate and you plan to keep the property for 2 or more years, it usually is the right thing to do. Just take out a pencil and paper and do the math. This is just like fixed/variable or points/no points--How long will you keep the property?

PAYMENT VS. INTEREST

Low monthly payments are desirable but far from the full story. As an example, I offered to lend John \$100,000. **All he cares about are low payments.**

I offer a fully amortized 10 year payment at 6%, \$1,110.21 a month. “The payments are way too high,” says John.

Okay, how about \$898.03 a month “That’s better” (7% 15 years)

How about \$836.44 a month “That’s much better” (8% 20 yrs. amortization, due in 10 yrs.)

How about \$810.06 a month “Great” (9-1/2% 40 yrs. amortization, due in 5 yrs.)

How about \$500.00 a month “Unbelievable (18% 40 years, negative amortization, HUGE balloon payment [\$147,775.96] due in 3 years)

How about \$-0- a month “Impossible” (24% no payments - all due in 2 yr.)

THINK INTEREST, NOT PAYMENTS.



FIRST HALF REVIEW

By now we have explored a *Promissory Note* which can be used with real property security, with personal property security or unsecured. This is a formal “IOU.”

“*Due on sale*” and “*alienation*” are no longer alien terms.

We have discussed the *Trust Deed*--the real estate document given as security for the Note, the parties to this document and its difference to a mortgage.

If your eyes were not closed during the math portion you can now check your lender’s figures on a monthly basis. If you are a lender, you can now figure out your own principal and interest breakdowns. *Amortized, partially amortized, interest only, negative amortization*--You are a whiz!

The term “*usury*” is no longer mysterious. You understand that negative amortization is not an uncontrollable roller coaster ride. You know two simple words (**PAY MORE**) that can retire a loan sooner and can save thousands of dollars in interest.

Everyday financing should be an available topic at cocktail parties. Adjustables, margins, teaser rates, bi-weekly mortgages--whatever--you will now be able to hold your own.

Now take a break and realize how much real estate information you have digested in one sitting. I promise the balance of the day will be far more interesting.

SECOND HALF INTRODUCTION

“This math deal is great, but I took this seminar for **“practical stuff...”**”

We will discuss the concept of dealing with your lender if you are “upside down” with your loan. We will also fully examine the actual mechanics of a non-judicial foreclosure. Once we become a “one hour foreclosure expert” we will explore the relationships between the Trustor, Trustee and Beneficiary during this process. Can this process be delayed, canceled or cured? What are TSG’s, “REO’s” and all those other terms the experts use? Let’s not forget the “B” word: bankruptcy. Finally, we will visit the actual Trustee’s Sale and explore conduct at that very unusual event.

The sale antics of the 40 thieves will get a few laughs even though those tactics are usually fraudulent in nature. The actual Trustee’s Sale is the culmination of someone’s property ownership and was originally designed to be the end of this course, however a bonus section was added for students interested in attending Trustee’s Sales for fun and profit.

Hopefully I will pique your interest and you will attend a sale or two, even if you have no real reason to do so. If you are an experienced real estate licensee or property owner you may wish to start attending those sales for profit. Fortunes have been made at these sales. You have seen many advertisements in newspapers and on television offering “get rich quick” seminars involving these Trustee’s Sales, however this is *not* a way to buy a new Mercedes in one week.



This course will warn you about the many dangers that await an unwary sale buyer. In no way is this short overview intended to prepare you to actually buy real estate at these sales; that is the subject of a totally independent course



UNDERWATER -- DEALING WITH YOUR LENDER

Example:

You paid \$200,000 for your property in 1990. The first trust deed is \$180,000 (seller carry back) at 10%, due in 2 more years. The property is worth \$160,000 but with selling costs and commissions you would net only \$148,600.

This is very simple if your personal credit is not A+ and not crucial to you. This is simply a game of poker. You get a chance to see the lender's hand at no cost.

Speech 1: "If I sold the property today I would only net \$148,600. I owe you \$180,000. I will give you a deed to the property (Deed in Lieu of Foreclosure) unless you reduce the principal balance to \$155,000, reduce the interest to 7%, reduce the payment accordingly and extend the term for five years. I have paid promptly every month for many years and will continue if you will modify your note."

Speech 2: "My mother will lend me money. I can pay off \$145,000. That is all we can come up with and it is far more than you will get if you foreclose."

Either approach is really a win/win deal for both you and the lender.

If you are dealing with a large lender this will usually not work. Large lenders have servicing departments, foreclosure departments, bankruptcy departments, asset management departments, etc. Common sense really doesn't work with most large lenders.

Though this may sound cynical, the only way to deal with most major lenders is to stop paying and ride out a long foreclosure "rent free." Or stop paying and arrange a "short sale" with them. In most cases you have to *stop paying* just to get their attention*--What a waste! If your credit is paramount, you will have to keep on paying and wait out the next real estate cycle or sell now and put in the cash difference to close the escrow.

Try to find the "man in the basement with the green eyeshades."

Talk to a real estate broker who specializes in short sales.

*If you have good or excellent credit this can be a major setback, but it will not stop you from buying real estate in the future.

Good luck

NOD p. 1

97 782000

RECORDING REQUESTED BY

OLD RECORDS
COMPANY

AND WHEN RECORDED MAIL TO:

Foothill Conveyance Corporation
P.O. Box 26
Montrose, CA 91021-0026

RECORDED/FILED IN OFFICIAL RECORDS
RECORDER'S OFFICE
LOS ANGELES COUNTY
CALIFORNIA
12:41 PM MAY 27 1997

FEE \$10
DAF \$2
C-20 2

LOAN NO. 13080 FST OTHER REF. 797350-35 T.S. NO. FCC 2588

NOTICE OF DEFAULT AND ELECTION TO SELL UNDER DEED OF TRUST

IMPORTANT NOTICE

IF YOUR PROPERTY IS IN FORECLOSURE BECAUSE YOU ARE BEHIND IN YOUR PAYMENTS, IT MAY BE SOLD WITHOUT ANY COURT ACTION,

and you may have the legal right to bring your account in good standing by paying all of your past due payments plus permitted costs and expenses within the time permitted by law for reinstatement of your account which is normally five business days prior to the date set for the sale of your property. No sale date may be set until three months from the date this notice of default may be recorded (which date of recordation appears on this notice).

This amount is \$ 1,011.46 as of May 22, 1997, and will increase until your account becomes current. While your property is in foreclosure, you still must pay other obligations (such as insurance and taxes) required by your note and deed of trust or mortgage. If you fail to make future payments on the loan, pay taxes on the property, provide insurance on the property, or pay other obligations as required in the note and deed of trust or mortgage, the beneficiary or mortgagee may insist that you do so in order to reinstate your account in good standing. In addition, the beneficiary or mortgagee may require as a condition to reinstatement that you provide reliable written evidence that you paid all senior liens, property taxes, and hazard insurance premiums.

Upon your written request, the beneficiary or mortgagee will give you a written itemization of the entire amount you must pay. You may not have to pay the entire unpaid portion of your account, even though full payment was demanded, but you must pay all amounts in default at the time payment is made. However, you and your beneficiary or mortgagee may mutually agree in writing prior to the time the notice of sale is posted (which may not be earlier than the end of the three-month period stated above) to, among other things, (1) provide additional time in which to cure the default by transfer of the property or otherwise; or (2) establish a schedule of payments in order to cure your default; or both (1) and (2).

Following the expiration of the time period referred to in the first paragraph of this notice, unless the obligation being foreclosed upon or a separate written agreement between you and your creditor permits a longer period, you have only the legal right to stop the sale of your property by paying the entire amount demanded by your creditor.

To find out the amount you must pay, or to arrange for payment to stop the foreclosure, or if your property is in foreclosure for any other reason, contact:

Name of Beneficiary or Mortgagee
V.I.P. Trust Deed Company
c/o Foothill Conveyance Corporation
P.O. Box 26
Montrose, CA 91021-0026
Phone: (818)248-0000

If you have any questions, you should contact a lawyer or the Governmental agency which may have insured your loan.

Notwithstanding the fact that your property is in foreclosure, you may offer your property for sale, provided the sale is concluded prior to the conclusion of the foreclosure.

Remember, YOU MAY LOSE LEGAL RIGHTS IF YOU DO NOT TAKE PROMPT ACTION.

Notice of Default - Page 1

797350-35

NOD p. 2

NOTICE OF DEFAULT AND ELECTION TO SELL UNDER DEED OF TRUST

LOAN NO. 13080 FST

OTHER REF. 797350-35

T.S. NO. FCC 2588

NOTICE IS HEREBY GIVEN: That FOOTHILL CONVEYANCE CORPORATION, a California Corporation, is duly appointed or substituted Trustee under a Deed of Trust dated December 18, 1995 executed by JOHN BORROWER AND MARY BORROWER, Husband and Wife as Community Property

as Trustor, to secure certain obligations in favor of V.I.P. TRUST DEED COMPANY, a California Corporation

Recorded January 23, 1996, as Instrument No. 96-124055, Book _____, Page _____, and Re-recorded _____, as Instrument No. _____, Book _____, Page _____ of Official Records in the office of the Recorder of Los Angeles County, California, describing the land therein:

AS DESCRIBED IN THE ABOVE REFERENCED DEED OF TRUST

including one note(s) for the sum of \$50,000.00; that the beneficial interest under such Deed of Trust and the obligations secured thereby are presently held by the undersigned; that a breach of, and default in, the obligations for which such Deed of Trust is security has occurred in that payment has not been made of: The installment of interest which became due April 23, 1997, plus all subsequent installments of interest, plus late fees, plus delinquent taxes, plus fees and costs.

Agent for that by reason thereof, the undersigned, present beneficiary, under such Deed of Trust, has executed and delivered to said duly appointed Trustee, a written Declaration of Default and Demand for Sale, and has deposited with said duly appointed Trustee, such Deed of Trust and all documents evidencing obligations secured thereby, and has declared and does hereby declare all sums secured thereby immediately due and payable and has elected and does hereby elect to cause the trust property to be sold to satisfy the obligations secured thereby. *NOTE: Payment on the above must be cash or certified funds only.

Dated: May 22, 1997

Foothill Conveyance Corporation

By: [Signature] Peter Rosenthal, President

noddtp2

Page 2

97 782666

NOTICE OF DEFAULT

Hopefully you will never receive one of these with your name as Trustor. If you do receive one, the world has not come to an end. This document is merely the start of the non-judicial foreclosure process and is usually “curable.”

Prior to the execution of this document, the Beneficiary has given the Trustee a “Declaration of Default” outlining the exact reason for the default and the figures involved.

The Notice of Default (NOD) is recorded at the County Recorder’s office. The Notice of Default clearly spells out the “breach” or default. This default might be ”a failure to pay the installment of principal and interest which became due August 1, 1997 and all subsequent installments of principal and interest, late charges, delinquencies on prior encumbrances, advances, delinquent real estate taxes, attorney’s fees, if any, plus fees and costs.”

The default might also be “a failure to pay the principal sum (balloon payment) which became due August 1, 1997 plus interest due thereon plus late fees, plus fees and costs.”

The default may be “non-monetary,” such as unauthorized transfers, further encumbrance, waste, etc.

The Trustee orders a Trustee’s Sale Guarantee (TSG), which is similar to a title policy. It insures the Trustee and Beneficiary and provides the Trustee with the necessary lien mailing and publication information. Using this TSG, the Trustee sends the NOD by certified and first class mailings within ten days of filing the NOD. The NOD is sent to the Trustor at the address listed on the Trust Deed. The NOD is also sent to anyone of record other than the Trustor who has recorded a “Request for Notice of Default.”

A second set of mailings is sent to other parties of interest within 30 days of the NOD recording. These mailings are sent to the Beneficiary of any recorded junior trust deed, recorded leaseholders, creditors with recorded judgments, etc.

The first stage of the three part foreclosure process has now been completed. This is sometimes called “the curing period.” If the default is “curable,” the Trustor may pay all amounts due at that time, including all foreclosure fees and costs. The Beneficiary pays nothing if the foreclosure is cured.

Nothing further happens for the three month period following the recording of the NOD.

TSG p. 1

FGIS 2100A

LIMITED TRUSTEE'S SALE GUARANTEE

Guarantee No. 6745 Ref. No. FCC 2588

SUBJECT TO THE EXCLUSIONS FROM COVERAGE, THE LIMITS OF LIABILITY AND THE OTHER PROVISIONS OF THE CONDITIONS AND STIPULATIONS HERETO ANNEXED AND MADE A PART OF THIS GUARANTEE,



OLD REPUBLIC NATIONAL TITLE INSURANCE COMPANY

a Corporation, of Minneapolis, Minnesota
Home Office: 400 - 2nd Ave. So., Minneapolis, Minn. 55401
herein called the Company,

GUARANTEES

the Assured name in Part 2 of this Guarantee

against loss not exceeding the liability amount stated in Part 2 which the assured shall sustain by reason of any incorrectness in the assurance which the Company hereby gives that, according to the public records, as of the Date of Guarantee shown in Part 2:

- 1. The title to the herein described estate or interest was vested in the vestee named.
2. The names and addresses of persons who have recorded requests, as provided by Section 2924b (a) and (d) of the Civil Code, for a copy of notice of default and for a copy of notice of sale are shown herein;
3. The names and addresses of additional persons who, as provided by Section 2924b (c) (1) and (2) of the Civil Code, are entitled to receive a copy of notice of default and a copy of notice of sale are shown herein;
4. The names and addresses of state taxing agencies which, as provided by Section 2924b (c) (3) of the Civil Code, are entitled to receive a copy of notice of sale, are as shown herein; and
5. There are no

- Mortgages,
Assignments of the beneficiary's or mortgagee's interests under deeds of trust or mortgages,
Contracts of sale or leases,
Assignments of the vendee's or lessee's interest under contracts of sale or leases,
Notices of lien or postponed property taxes by the office of the State Controller, Sacramento, California,
Notices of federal tax liens, or interests of record,

which are recorded in the public records subsequent to or have been subordinated by a document recorded in the public records to the Foreclosing Mortgage, other than those shown in paragraph 5 of Part 2 of this guarantee.

- 6. The herein described land is located in the city or judicial district stated herein and, if designated, the newspaper or newspapers listed herein qualify for publication of notice pursuant to Section 2924f of the Civil Code.

OLD REPUBLIC NATIONAL TITLE INSURANCE COMPANY
A Corporation
400 Second Avenue South, Minneapolis, Minnesota 55401
(612) 371-1111

Countersigned: [Signature]
By [Signature]
Validating Officer

By: [Signature] President
Attest: [Signature] Secretary

GUARANTEE CONDITIONS AND STIPULATIONS

1. DEFINITION OF TERMS

The following terms when used in this Guarantee mean:

- (a) "the Assured": the party or parties named as the Assured in this Guarantee, or on a supplemental writing executed by the Company.
- (b) "land": the land described or referred to in Schedule (A)(C) or in Part 2, and improvements affixed thereto which by law constitute real property. The term "land" does not include any property beyond the lines of the area described or referred to in Schedule (A)(C) or in Part 2, nor any right, title, interest estate or easement in abutting streets, roads, avenues, alleys, lanes, ways or waterways.
- (c) "mortgage": mortgage, deed of trust, trust deed, or other security instrument.
- (d) "public records": records established under state statutes at Date of Guarantee for the purpose of imparting constructive notice of matters relating to real property to purchasers for value and without knowledge.
- (e) "date": the effective date.

2. EXCLUSIONS FROM COVERAGE OF THIS GUARANTEE

The Company assumes no liability for loss or damage by reason of the following:

- (a) Taxes or assessments which are not shown as existing liens by the records of any taxing authority that levies taxes or assessments on real property or by the public records.
- (b) (1) Unpatented mining claims; (2) reservations or exceptions in patents or in Acts authorizing the issuance thereof; (3) water rights, claims or title to water: whether or not the matters excluded by (1), (2), or (3) are shown by the public records.
- (c) Assurances to title to any property beyond the lines of the land expressly described in the description set forth in Schedule (A)(C) or in Part 2 of this Guarantee, or title to streets, roads, avenues, lanes, ways or waterways on which such land abuts, or the right to maintain therein vaults, tunnels, ramps or any other structure or improvement; or any rights or easements therein unless such property, rights or easements are expressly and specifically set forth in said description.
- (d) (1) Defects, liens, encumbrances or adverse claims against the title, if assurances are provided as to such title, and as limited by such assurances.
(2) Defects, liens, encumbrances, adverse claims or other matters (a) whether or not shown by the public records, and which are created, suffered, assumed or agreed to by one or more of the Assureds; (b) which result in no loss to the Assured; or (c) which do not result in the invalidity or potential invalidity of any judicial or non-judicial proceeding which is within the scope and purpose of assurances provided.

3. NOTICE OF CLAIM TO BE GIVEN BY ASSURED CLAIMANT

An Assured shall notify the Company promptly in writing in case knowledge shall come to an Assured hereunder of any claim of title or interest which is adverse to the title to the estate or interest, as stated herein, and which might cause loss or damage for which the Company may be liable by virtue of this Guarantee. If prompt notice shall not be given to the Company, then all liability of the Company shall terminate with regard to the matter or matters for which prompt notice is required; provided, however, that failure to notify the Company shall in no case prejudice the rights of any Assured under this Guarantee unless the Company shall be prejudiced by the failure and then only to the extent of the prejudice.

4. NO DUTY TO DEFEND OR PROSECUTE

The Company shall have no duty to defend or prosecute any action or proceeding to which the Assured is a party, notwithstanding the nature of any allegation in such action or proceeding.

5. COMPANY'S OPTION TO DEFEND OR PROSECUTE ACTIONS; DUTY OF ASSURED CLAIMANT TO COOPERATE.

Even though the Company has no duty to defend or prosecute as set forth in Paragraph 4 above:

- (a) The Company shall have the right, at its sole option and cost, to institute and prosecute any action or proceeding, interpose a defense, as limited in (b), or to do any other act which in its opinion may be necessary or desirable to establish the title to the

estate or interest as stated herein, or to establish the lien rights of the Assured, or to prevent or reduce loss or damage to the Assured. The Company may take any appropriate action under the terms of this Guarantee, whether or not it shall be liable hereunder, and shall not thereby concede liability or waive any provision of this Guarantee. If the Company shall exercise its rights under this paragraph, it shall do so diligently.

(b) If the Company elects to exercise its options as stated in Paragraph 5(a) the Company shall have the right to select counsel of its choice (subject to the right of such Assured to object for reasonable cause) to represent the Assured and shall not be liable for and will not pay the fees of any other counsel, nor will the Company pay any fees, costs or expenses incurred by an Assured in the defense of those causes of action which allege matters not covered by this Guarantee.

(c) Whenever the Company shall have brought an action or interposed a defense as permitted by the provisions of this Guarantee, the Company may pursue any litigation to final determination by a court of competent jurisdiction and expressly reserves the right, in its sole discretion, to appeal from an adverse judgment or order.

(d) In all cases where this Guarantee permits the Company to prosecute or provide for the defense of any action or proceeding, an Assured shall secure to the Company the right to so prosecute or provide for the defense of any action or proceeding, and all appeals therein, and permit the Company to use, at its option, the name of such Assured for this purpose. Whenever requested by the Company, an Assured, at the Company's expense, shall give the Company all reasonable aid in any action or proceeding, securing evidence, obtaining witnesses, prosecuting or defending the action or lawful act which in the opinion of the Company may be necessary or desirable to establish the title to the estate or interest as stated herein, or to establish the lien rights of the Assured. If the Company is prejudiced by the failure of the Assured to furnish the required cooperation, the Company's obligations to the Assured the Guarantee shall terminate.

6. PROOF OF LOSS OR DAMAGE

In addition to and after the notices required under Section 3 of these Conditions and Stipulations have been provided to the Company, a proof of loss or damage signed and sworn to by the Assured shall be furnished to the Company within ninety (90) days after the Assured shall ascertain the facts giving rise to the loss or damage. The proof of loss or damage shall describe the matters covered by this Guarantee which constitute the basis of loss or damage and shall state, to the extent possible, the basis of calculating the amount of the loss or damage. If the Company is prejudiced by the failure of the Assured to provide the required proof of loss or damage, the Company's obligation to such Assured under the Guarantee shall terminate. In addition, the Assured may reasonably be required to submit to examination under oath by any authorized representative of the Company an shall produce for examination, inspection and copying, at such reasonable times and places as may be designated by any authorized representative of the Company, all records, books, ledgers, checks, correspondence and memoranda, whether bearing a date before or after Date of Guarantee which reasonably pertain to the loss or damage. Further, if requested by any authorized representative of the Company, the Assured shall grant its permission, in writing, for any authorized representative of the Company to examine, inspect and copy all records, books, ledgers, checks, correspondence and memoranda in the custody or control of a third party, which reasonably pertain to the loss or damage. All information designated as confidential by the Assured provided to the Company pursuant to this Section shall not be disclosed to others unless, in the reasonable judgment of the Company, it is necessary in the administration of the claim. Failure of the Assured to submit for examination under oath, produce other reasonably requested information or grant permission to secure reasonably necessary information from third parties as required in the above paragraph, unless prohibited by law or governmental regulation, shall terminate any liability of the Company under this Guarantee to the Assured for that claim.

7. OPTIONS TO PAY OR OTHERWISE SETTLE CLAIMS - TERMINATION OF LIABILITY

In case of a claim under this Guarantee, the Company shall have the following additional options:

GUARANTEE CONDITIONS AND STIPULATIONS (Continuation)

(a) To Pay or Tender Payment of the Amount of Liability or to Purchase the Indebtedness.

The Company shall have the option to pay or settle or compromise for or in the name of the Assured any claim which could result in loss to the Assured within the coverage of this Guarantee, or to pay the full amount of this Guarantee or, if this Guarantee is issued for the benefit of a holder of a mortgage or a lienholder, the Company shall have the option to purchase the indebtedness secured by said mortgage or said lien for the amount owing thereon, together with any costs, reasonable attorneys' fees and expenses incurred by the Assured claimant which were authorized by the Company up to the time of purchase.

Such purchase, payment or tender of payment of the full amount of the Guarantee shall terminate all liability of the Company hereunder. In the event after notice of claim has been given to the Company by the Assured the Company offers to purchase said indebtedness, the owner of such indebtedness shall transfer and assign said indebtedness, together with any collateral security, to the Company upon payment of the purchase price.

Upon the exercise by the Company of the option provided for in Paragraph (a) the Company's obligation to the Assured under this Guarantee for the claimed loss or damage, other than to make the payment required in that paragraph, shall terminate, including any obligation to continue the defense or prosecution of any litigation for which the Company has exercised its options under Paragraph 5, and the Guarantee shall be surrendered to the Company for cancellation.

(b) To Pay or Otherwise Settle With Parties Other Than the Assured or With the Assured Claimant.

To pay or otherwise settle with other parties for or in the name of an Assured claimant any claim assured against under this Guarantee, together with any costs, attorneys' fees and expenses incurred by the Assured claimant which were authorized by the Company up to the time of payment and which the Company is obligated to pay.

Upon the exercise by the Company of the option provided for in Paragraph (b) The Company's obligation to the Assured under this Guarantee for the claimed loss or damage, other than to make the payment required in that paragraph, shall terminate, including any obligation to continue the defense or prosecution of any litigation for which the Company has exercised its options under Paragraph 5.

8. DETERMINATION AND EXTENT OF LIABILITY

This Guarantee is a contract of indemnity against actual monetary loss or damage sustained or incurred by the Assured claimant who has suffered loss or damage by reason of reliance upon the assurances set forth in this Guarantee and only to the extent herein described, and subject to the exclusions stated in Paragraph 2.

The liability of the Company under this Guarantee to the Assured shall not exceed the least of:

- (a) the amount of liability stated in Schedule A;
- (b) the amount of the unpaid principal indebtedness secured by the mortgage of an Assured mortgagee, as limited or provided under Section 7 of these Conditions and Stipulations or as reduced under Section 10 of these Conditions and Stipulations, at the time the loss or damage assured against by this Guarantee occurs, together with interest thereon; or
- (c) the difference between the value of the estate or interest covered hereby as stated herein and the value of the estate or interest subject to any defect, lien or encumbrance assured against by the Guarantee.

9. LIMITATION OF LIABILITY

(a) If the Company establishes the title, or removes the alleged defect, lien or encumbrance, or cures any other matter assured against by this Guarantee in a reasonably diligent manner by any method, including litigation and the completion of any appeals therefrom, it shall have fully performed its obligations with respect to that matter and shall not be liable for any loss or damage caused thereby.

(b) In the event of any litigation by the Company or with the Company's consent, the Company shall have no liability for loss or damage until there has been a final determination by a court of competent jurisdiction, and disposition of all appeals therefrom, adverse to the title, as stated herein.

(c) The Company shall not be liable for loss or damage to any Assured for liability voluntarily assumed by the Assured in settling any claim or suit without the prior written consent of the Company.

CLTA Guarantee Attachment (Conditions and Stipulations)(Rev 6-6-92)

10. REDUCTION OF LIABILITY OR TERMINATION OF LIABILITY.

All payments under this Guarantee, except payments made for costs, attorneys' fees and expenses pursuant to paragraph 5 shall reduce the amount of liability pro tanto.

11. PAYMENT OF LOSS.

(a) No payment shall be made without producing this Guarantee for endorsement of the payment unless the Guarantee has been lost or destroyed, in which case proof of loss or destruction shall be furnished to the satisfaction of the Company.

(b) When liability and the extent of loss or damage has been definitely fixed in accordance with these Conditions and Stipulations, the loss or damage shall be payable within thirty (30) days thereafter.

12. SUBROGATION UPON PAYMENT OR SETTLEMENT.

Whenever the Company shall have settled and paid a claim under this Guarantee, all right of subrogation shall vest in the Company unaffected by any act of the Assured claimant.

The Company shall be subrogated to an be entitled to all rights and remedies which the Assured would have had against any person or property in respect to the claim had this Guarantee not been issued. If requested by the Company, the Assured shall transfer to the Company all rights and remedies against any person or property necessary in order to perfect this right of subrogation. The Assured shall permit the Company to sue, compromise or settle in the name of the Assured and to use the name of the Assured in any transaction or litigation involving these rights or remedies.

If a payment on account of a claim does not fully cover the loss of the Assured the Company shall be subrogated to all rights and remedies of the Assured after the Assured shall have recovered its principal, interest, and costs of collection.

13. ARBITRATION.

Unless prohibited by applicable law, either the Company or the Assured may demand arbitration pursuant to the Title Insurance Arbitration Rules of the American Arbitration Association.

Arbitrable matters may include, but are not limited to, any controversy or claim between the Company and the Assured arising out of or relating to this Guarantee, any service of the Company in connection with its issuance or the breach of a Guarantee provision or other obligation. All arbitrable matters when the amount of liability is \$1,000,000 or less shall be arbitrated at the option of either the Company or the Assured. All arbitrable matters when the amount of liability is in excess of \$1,000,000 shall be arbitrated only when agreed to by both the Company and the Assured. The Rules in effect at Date of Guarantee shall be binding upon the parties. The award may include attorneys' fees only if the laws of the state in which the land is located permits a court to award attorneys' fees to a prevailing party. Judgment upon the award rendered by the Arbitrator(s) may be entered in any court having jurisdiction thereof.

The law of the situs of the land shall apply to an arbitration under the Title Insurance Arbitration Rules.

A copy of the Rules may be obtained from the Company upon request.

14. LIABILITY LIMITED TO THIS GUARANTEE; GUARANTEE ENTIRE CONTRACT.

(a) This Guarantee together with all endorsements, if any, attached hereto by the Company is the entire Guarantee and contract between the Assured and the Company. In interpreting any provision of this Guarantee, this Guarantee shall be construed as a whole.

(b) Any claim of loss or damage, whether or not based on negligence, or any action asserting such claim, shall be restricted to this Guarantee.

(c) No amendment of or endorsement to this Guarantee can be made except by a writing endorsed hereon or attached hereto signed by either the President, a Vice President, the Secretary, an Assistant Secretary, or validating officer or authorized signatory of the Company.

15. NOTICES, WHERE SENT.

All notices required to be given the Company and any statement in writing required to be furnished the Company shall include the number of this Guarantee and shall be addressed to the Company at the office which issued this Guarantee or to its Home Office, Minneapolis, Minnesota.

GUARANTEE CONDITIONS AND STIPULATIONS

1. DEFINITION OF TERMS

The following terms when used in this Guarantee mean:

- (a) "the Assured": the party or parties named as the Assured in this Guarantee, or on a supplemental writing executed by the Company.
- (b) "land": the land described or referred to in Schedule (A)(C) or in Part 2, and improvements affixed thereto which by law constitute real property. The term "land" does not include any property beyond the lines of the area described or referred to in Schedule (A)(C) or in Part 2, nor any right, title, interest estate or easement in abutting streets, roads, avenues, alleys, lanes, ways or waterways.
- (c) "mortgage": mortgage, deed of trust, trust deed, or other security instrument.
- (d) "public records": records established under state statutes at Date of Guarantee for the purpose of imparting constructive notice of matters relating to real property to purchasers for value and without knowledge.
- (e) "date": the effective date.

2. EXCLUSIONS FROM COVERAGE OF THIS GUARANTEE

The Company assumes no liability for loss or damage by reason of the following:

- (a) Taxes or assessments which are not shown as existing liens by the records of any taxing authority that levies taxes or assessments on real property or by the public records.
- (b) (1) Unpatented mining claims; (2) reservations or exceptions in patents or in Acts authorizing the issuance thereof; (3) water rights, claims or title to water: whether or not the matters excluded by (1), (2), or (3) are shown by the public records.
- (c) Assurances to title to any property beyond the lines of the land expressly described in the description set forth in Schedule (A)(C) or in Part 2 of this Guarantee, or title to streets, roads, avenues, lanes, ways or waterways on which such land abuts, or the right to maintain therein vaults, tunnels, ramps or any other structure or improvement; or any rights or easements therein unless such property, rights or easements are expressly and specifically set forth in said description.
- (d) (1) Defects, liens, encumbrances or adverse claims against the title, if assurances are provided as to such title, and as limited by such assurances.
(2) Defects, liens, encumbrances, adverse claims or other matters (a) whether or not shown by the public records, and which are created, suffered, assumed or agreed to by one or more of the Assureds; (b) which result in no loss to the Assured; or (c) which do not result in the invalidity or potential invalidity of any judicial or non-judicial proceeding which is within the scope and purpose of assurances provided.

3. NOTICE OF CLAIM TO BE GIVEN BY ASSURED CLAIMANT

An Assured shall notify the Company promptly in writing in case knowledge shall come to an Assured hereunder of any claim of title or interest which is adverse to the title to the estate or interest, as stated herein, and which might cause loss or damage for which the Company may be liable by virtue of this Guarantee. If prompt notice shall not be given to the Company, then all liability of the Company shall terminate with regard to the matter or matters for which prompt notice is required; provided, however, that failure to notify the Company shall in no case prejudice the rights of any Assured under this Guarantee unless the Company shall be prejudiced by the failure and then only to the extent of the prejudice.

4. NO DUTY TO DEFEND OR PROSECUTE

The Company shall have no duty to defend or prosecute any action or proceeding to which the Assured is a party, notwithstanding the nature of any allegation in such action or proceeding.

5. COMPANY'S OPTION TO DEFEND OR PROSECUTE ACTIONS; DUTY OF ASSURED CLAIMANT TO COOPERATE.

Even though the Company has no duty to defend or prosecute as set forth in Paragraph 4 above:

- (a) The Company shall have the right, at its sole option and cost, to institute and prosecute any action or proceeding, interpose a defense, as limited in (b), or to do any other act which in its opinion may be necessary or desirable to establish the title to the

estate or interest as stated herein, or to establish the lien rights of the Assured, or to prevent or reduce loss or damage to the Assured. The Company may take any appropriate action under the terms of this Guarantee, whether or not it shall be liable hereunder, and shall not thereby concede liability or waive any provision of this Guarantee. If the Company shall exercise its rights under this paragraph, it shall do so diligently.

(b) If the Company elects to exercise its options as stated in Paragraph 5(a) the Company shall have the right to select counsel of its choice (subject to the right of such Assured to object for reasonable cause) to represent the Assured and shall not be liable for and will not pay the fees of any other counsel, nor will the Company pay any fees, costs or expenses incurred by an Assured in the defense of those causes of action which allege matters not covered by this Guarantee.

(c) Whenever the Company shall have brought an action or interposed a defense as permitted by the provisions of this Guarantee, the Company may pursue any litigation to final determination by a court of competent jurisdiction and expressly reserves the right, in its sole discretion, to appeal from an adverse judgment or order.

(d) In all cases where this Guarantee permits the Company to prosecute or provide for the defense of any action or proceeding, an Assured shall secure to the Company the right to so prosecute or provide for the defense of any action or proceeding, and all appeals therein, and permit the Company to use, at its option, the name of such Assured for this purpose. Whenever requested by the Company, an Assured, at the Company's expense, shall give the Company all reasonable aid in any action or proceeding, securing evidence, obtaining witnesses, prosecuting or defending the action or lawful act which in the opinion of the Company may be necessary or desirable to establish the title to the estate or interest as stated herein, or to establish the lien rights of the Assured. If the Company is prejudiced by the failure of the Assured to furnish the required cooperation, the Company's obligations to the Assured the Guarantee shall terminate.

6. PROOF OF LOSS OR DAMAGE.

In addition to and after the notices required under Section 3 of these Conditions and Stipulations have been provided to the Company, a proof of loss or damage signed and sworn to by the Assured shall be furnished to the Company within ninety (90) days after the Assured shall ascertain the facts giving rise to the loss or damage. The proof of loss or damage shall describe the matters covered by this Guarantee which constitute the basis of loss or damage and shall state, to the extent possible, the basis of calculating the amount of the loss or damage. If the Company is prejudiced by the failure of the Assured to furnish the required proof of loss or damage, the Company's obligation to such Assured under the Guarantee shall terminate. In addition, the Assured may reasonably be required to submit to examination under oath by any authorized representative of the Company an shall produce for examination, inspection and copying, at such reasonable times and places as may be designated by any authorized representative of the Company, all records, books, ledgers, checks, correspondence and memoranda, whether bearing a date before or after Date of Guarantee which reasonably pertain to the loss or damage. Further, if requested by any authorized representative of the Company, the Assured shall grant its permission, in writing, for any authorized representative of the Company to examine, inspect and copy all records, books, ledgers, checks, correspondence and memoranda in the custody or control of a third party, which reasonably pertain to the loss or damage. All information designated as confidential by the Assured provided to the Company pursuant to this Section shall not be disclosed to others unless, in the reasonable judgment of the Company, it is necessary in the administration of the claim. Failure of the Assured to submit for examination under oath, produce other reasonably requested information or grant permission to secure reasonably necessary information from third parties as required in the above paragraph, unless prohibited by law or governmental regulation, shall terminate any liability of the Company under this Guarantee to the Assured for that claim.

7. OPTIONS TO PAY OR OTHERWISE SETTLE CLAIMS - TERMINATION OF LIABILITY

In case of a claim under this Guarantee, the Company shall have the following additional options:

TSG p 5

LIMITED TRUSTEE'S SALE GUARANTEE - PART 2

ORDER NO.: 797350-35

REF. NO.: FCC 2588

GUARANTEE NO.: LTG 6745

LIABILITY: \$55,000.00

DATE OF GUARANTEE: MAY 27, 1997 AT 12:41 P.M.

FEE: \$150.00

1. NAME OF ASSURED:

V.I.P. TRUST DEED COMPANY, A CALIFORNIA CORPORATION

FOOTHILL CONVEYANCE CORPORATION, A CALIFORNIA CORPORATION

2. THE ESTATE OR INTEREST IN THE LAND HEREINAFTER DESCRIBED OR REFERRED TO COVERED BY THIS GUARANTEE IS:

A CONDOMINIUM AS DEFINED IN SECTION 783 OF THE CALIFORNIA CIVIL CODE, IN FEE.

3. TITLE TO SAID ESTATE OR INTEREST AT THE DATE HEREOF IS VESTED IN:

JOHN BORROWER AND MARY BORROWER, HUSBAND AND WIFE AS COMMUNITY PROPERTY

4. THE LAND REFERRED TO IN THIS GUARANTEE IS SITUATED IN THE CITY OF LOS ANGELES, COUNTY OF LOS ANGELES, STATE OF CALIFORNIA, AND IS DESCRIBED AS FOLLOWS:

SEE ATTACHED EXHIBIT "A"

5. EXCEPTIONS:

SEE ATTACHED "EXCEPTIONS"

TSG p 6

EXHIBIT "A"

A CONDOMINIUM COMPRISED OF:

PARCEL 1:

(A) AN UNDIVIDED 1/28 INTEREST IN LOT 1 OF TRACT NO. 28294, IN THE CITY OF LOS ANGELES, COUNTY OF LOS ANGELES, STATE OF CALIFORNIA, AS PER MAP RECORDED IN BOOK 1023 PAGES 97 AND 98 OF MAPS, IN THE OFFICE OF THE COUNTY RECORDER OF SAID COUNTY.

EXCEPT UNITS 1 TO 28 INCLUSIVE AS SHOWN AND DEFINED ON THE CONDOMINIUM PLAN RECORDED AUGUST 10, 1984 AS INSTRUMENT NO. 84-960578 IN SAID OFFICE OF THE COUNTY RECORDER.

(B) UNIT 28, AS SHOWN AND DEFINED ON THE CONDOMINIUM PLAN REFERRED TO ABOVE.

TSG p 7

"EXCEPTIONS"

1. TAXES, GENERAL AND SPECIAL, FOR THE FISCAL YEAR 1997-1998, A LIEN, BUT NOT YET DUE OR PAYABLE.
2. TAXES, GENERAL AND SPECIAL, FOR THE FISCAL YEAR 1996-1997, AS FOLLOWS:

TOTAL	:	\$759.30
1ST INSTALLMENT	:	\$379.65 + PENALTY OF \$37.97
2ND INSTALLMENT	:	\$379.65 + PENALTY OF \$47.97
TRA NO.	:	00013
3. THE FOLLOWING MATTERS ARE AS SHOWN IN THE RECORDS OF THE TAX COLLECTOR OF SAID COUNTY:

APN	:	2565-013-08
SITUS ADDRESS	:	10149 COMMERCE AVE TUJUNGA CA 91042
4. ANY UNPAID AND/OR DELINQUENT BOND OR ASSESSMENT AMOUNTS DUE WHICH MAY HAVE BEEN REMOVED FROM THE ROLLS OF THE COUNTY TAX ASSESSOR AND WHICH MAY HAVE BEEN REMOVED FROM TAX BILLS AND TAX DEFAULT REDEMPTION AMOUNTS.
5. THE LIEN OF SUPPLEMENTAL TAXES, IF ANY, ASSESSED PURSUANT TO THE PROVISIONS OF SECTION 75, ET SEQ. OF THE REVENUE AND TAXATION CODE OF THE STATE OF CALIFORNIA.
6. DEED OF TRUST TO SECURE AN INDEBTEDNESS OF THE AMOUNT STATED BELOW AND ANY OTHER AMOUNTS PAYABLE UNDER THE TERMS THEREOF,

AMOUNT	:	\$50,000.00
DATED	:	DECEMBER 18, 1995
TRUSTOR	:	JOHN BORROWER AND MARY BORROWER, HUSBAND AND WIFE AS COMMUNITY PROPERTY
TRUSTEE	:	FOOTHILL CONVEYANCE CORPORATION, A CALIFORNIA CORPORATION
BENEFICIARY	:	V.I.P. TRUST DEED COMPANY, A CALIFORNIA CORPORATION
RECORDED	:	JANUARY 23, 1996
INSTRUMENT NO.	:	96-124055, OFFICIAL RECORDS
LOAN NO. IF SHOWN	:	N/A

TSG p 8

INFORMATION FOR TRUSTEE

RELATIVE TO THE DEED OF TRUST SHOWN AS EXCEPTION NO. 6 IN PART 2.

1. CITY IN WHICH SAID LAND IS LOCATED: CITY OF LOS ANGELES
IF NOT IN A CITY, JUDICIAL DISTRICT IN WHICH SAID LAND IS LOCATED:

2. LEGAL PUBLICATION:

METROPOLITAN NEWS, PUBLISHED MONDAY THROUGH FRIDAY

3. THE NAMES AND ADDRESSES OF PERSONS WHO HAVE RECORDED REQUESTS, AS PROVIDED BY SECTION 2924b (a) AND (d) OF THE CIVIL CODE, FOR A COPY OF NOTICE OF DEFAULT AND FOR A COPY OF NOTICE OF SALE ARE:

JOHN BORROWER
10149 COMMERCE AVENUE #28
TUJUNGA, CA 91042

MARY BORROWER
10149 COMMERCE AVENUE #28
TUJUNGA, CA 91042

4. THE NAMES AND ADDRESSES OF ADDITIONAL PERSONS WHO, AS PROVIDED BY SECTION 2924b (c) (1) AND (2) OF THE CIVIL CODE, ARE ENTITLED TO RECEIVE A COPY OF NOTICE OF DEFAULT AND A COPY OF NOTICE OF SALE ARE:

V.I.P. TRUST DEED COMPANY
P. O. BOX 26
MONTROSE, CA 91021-0026

ALFRED E. NEUMANN
C/O V.I.P. TRUST DEED CO.
P.O. BOX 26
MONTROSE, CA 91021-0026

30 DAY NOTICES CONTINUED:

JEFFREY DAHMMER
2905 PINKERTON AVENUE
Tujunga, CA 91042

MARIBELLE DAHMMER
2906 PINKERTON AVENUE
Tujunga, CA 91042

JEFFREY DAHMMER
P. O. BOX 26
Montrose, CA 91021

MARIBELLE DAHMMER
P. O. BOX 26
Montrose, CA 91021

5. THE NAMES AND ADDRESSES OF STATE TAXING AGENCIES WHICH, AS PROVIDED BY SECTION 2924b (c) (3) OF THE CIVIL CODE, ARE ENTITLED TO RECEIVE A COPY OF NOTICE OF SALE ARE:

NONE

6. ATTENTION IS CALLED TO THE SOLDIERS' AND SAILORS' CIVIL RELIEF ACT OF 1940 AND AMENDMENTS THERETO AND THE MILITARY RESERVIST RELIEF ACT OF 1991 (SEC. 800 TO 810, MILITARY AND VETERANS CODE) WHICH CONTAIN INHIBITIONS AGAINST THE SALE OF LAND UNDER A DEED OF TRUST IF THE OWNER IS ENTITLED TO THE BENEFITS OF SAID ACTS.
7. ATTENTION IS CALLED TO THE FEDERAL TAX LIEN ACT OF 1966 (PUBLIC LAW 89-719) WHICH, AMONG OTHER THINGS, PROVIDES FOR THE GIVING OF WRITTEN NOTICE OF SALE IN A SPECIFIED MANNER TO THE SECRETARY OF TREASURY OR HIS OR HER DELEGATE AS A REQUIREMENT FOR THE DISCHARGE OR DIVESTMENT OF A FEDERAL TAX LIEN IN A NON-JUDICIAL SALE, AND ESTABLISHES WITH RESPECT TO SUCH A LIEN A RIGHT IN THE UNITED STATES TO REDEEM THE PROPERTY WITHIN A PERIOD OF 120 DAYS FROM THE DATE OF ANY SUCH SALE.

CLTA GUARANTEE FORM NO. 22
PART 3
(Rev. 6-10-94)

NTS

THE PUBLIC MAPS AND RECORDS DIVISION OF THE COUNTY OF LOS ANGELES, CALIFORNIA

2565 13
SHEET 1
100'

TRW-RED1
1-800-345-7334



Old Republic Title Company

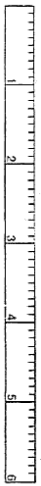

SCALE IN 1/16 OF AN INCH

NOV 14 1995
ASSASSOR'S MAP
COUNTY OF LOS ANGELES, CALIF.

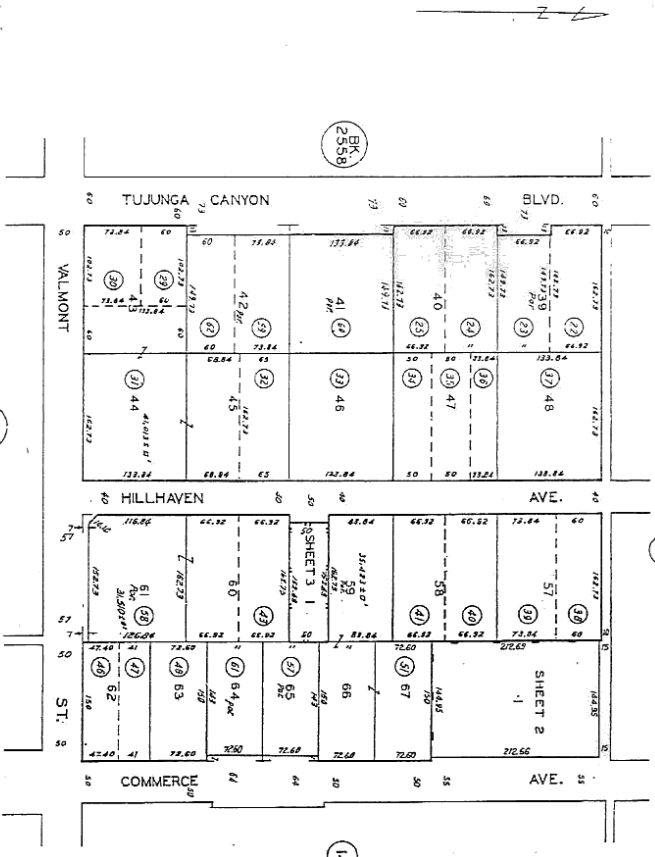

LOS TERRENITOS TRACT M.B. 23-38-39
CONDOMINIUM TRACT NO. 51141 M.B. 23-47-48
CONDOMINIUM TRACT NO. 28294 M.B. 1023-97-98

"This PLAT is for your aid in locating your land with reference to streets and other parcels. While this PLAT is believed to be correct, the COMPANY assumes no liability for any loss resulting by reason of reliance thereon."

LAW REID Property Data, Los Angeles, CA 1994-97 Map: 2565-13-1001



Old Republic Title Company

TRW-REID
1-800-345-7334

REVISED
5/28/95 (CORRECTED)
11/25/92 (REVISED)

SCALE 1/16 OF AN INCH
OFFICE OF ASSESSOR
COUNTY OF LOS ANGELES
COPYRIGHT © 1995

SCALE 1" = 30'

2565

13

AIRSPACE	PLAT NO	BLK	LOT	TYPE	SUBDIVISION
14	28224	-	1	(BUND)	SHEET 2
14	28224	-	1	(BUND)	SHEET 2
14	28224	-	1	(BUND)	SHEET 2
14	28224	-	1	(BUND)	SHEET 2
14	28224	-	1	(BUND)	SHEET 2

THE ASSESSMENT OF UNITS IN THE FOLLOWING AIRSPACE PLATS SET FORTH IN DEEDS OF RECORD FROM PLANS REFLECTS APPROXIMATE DIMENSIONS FROM WHICH AREAS ARE COMPUTED. AREAS ARE FOR CORRESPONDING ELEMENTS ONLY.

1996

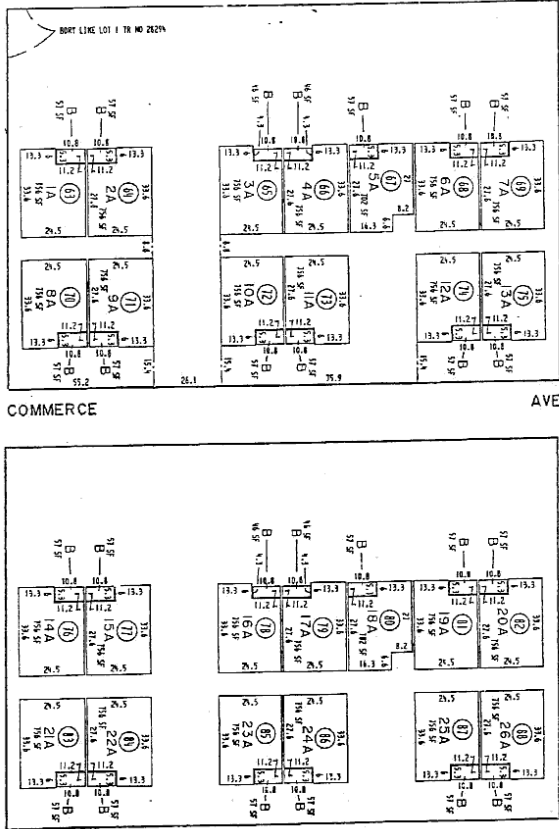

SUBDIVISION OF AIRSPACE
CONDOMINIUM TRACT NO 28224
FOR COMMON AREA SEE SHEET 1
SEE RECORDED CONDOMINIUM PLAN FOR ELEVATIONS OF UNITS.

NOV 14 1995

"This PLAT is for your aid in locating your land with reference to streets and other parcels. While this PLAT is believed to be correct, the COMPANY assumes no liability for any loss resulting by reason of reliance thereon"

NOTICE OF TRUSTEE'S SALE

Three months after recording the NOD, the Trustee records a "Notice of Trustee's Sale" (NTS). This document sets out the date, time and place of the upcoming sale (auction). The Notice also states the TOTAL amount of the obligation, including unpaid principal, all accruals, fees and costs expected at time of sale.

The Trustee now sends a new set of mailings (NTS) to all parties previously notified. Additional mailings are sent to the IRS if there is a Federal Tax Lien on the property. The Trustee also advertises the NTS in a general circulation newspaper once a week for three consecutive weeks, in addition to posting a Notice of Trustee's Sale on the property itself AND in a public place, usually a courthouse.

It is significantly more expensive to cure the default at this stage, as the Trustee's fees are increased at this point in addition to greatly increased costs for mailings, advertising, posting, etc.

At this point the foreclosure is still "curable" assuming the actual default is curable. Historically, the Beneficiary did not have to accept curing after three months; they could demand payment of the entire obligation. Foreclosure statutes were amended in recent years to allow curing up to five days before the actual sale.

BANKRUPTCY -- THE “B” WORD

Filing bankruptcy is a very drastic step and should not be taken without a lot of thought. Bankruptcy will not stop or cancel a foreclosure, only delay one. In fact, the legal fees incurred by the lender will be added to the debt and the Trustor in bankruptcy may only achieve a two or three month delay. Does the Trustor really have a lot of equity, or is this just a delay of the sale? It can be a very expensive delay.

Try to work with the lender instead. “Work Out Agreements” can be a “win/win” deal for both Beneficiary and Trustor. As an example:

1. Trustor to make one and one half payments per month until current.
2. Pay a sum for a one week or one month delay in sale date.
3. The Trustor can give the lender additional security in the form of a third party guarantee, a Deed of Trust on another property or even sign over the title to a car.

If there really is *substantial* equity to protect and the lender refuses to work with you, the “B” word is certainly an option. This delay, though costly, will give you an extra 2-5 months to sell the property. Why did you wait so long in the first place?

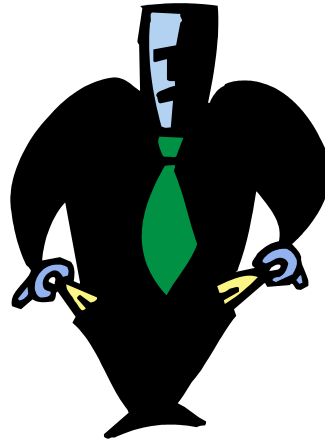



TRUSTEE'S SALE -- THE BIG EVENT

We are now at the actual sale, which can be held anywhere in the county where the property is located. This can be at the Trustee's office, but is usually held at the front, side or rear steps of a local courthouse.

Remember, this sale is ALL CASH OR CASHIER'S CHECK. Armed guards and armored trucks are not necessary, as most bidders come with cashier's checks.

The Trustee or an agent of the Trustee conducts the sale. Usually many sales are scheduled for the same day and the person conducting the sales usually announces all the cancellations and postponements first. Sometimes only a few spectators or bidders are present. At other sales ten to twenty people may show up. I conducted a sale on the front steps of the Glendale courthouse over a decade ago and nobody was at the sale. It amused me to stand there, all alone, reading the Trustee's Sale spiel out loud to a few pigeons. I have not personally conducted a sale in many years.

Most sales will not be held on the original day of sale. The sale may be postponed by "beneficiary's request"* or by "mutual consent." The sale may be postponed by bankruptcy or other "operation of law" or sometimes solely "at Trustee's discretion." For whatever reason, it is common to observe 2-10 postponements before the actual sale is held.

*If the Beneficiary postpones the sale more than three times, the entire posting and publishing process must start all over again. More on this in the "40 Thieves" segment.

Finally the person conducting the sale announces the sale on the property you are interested in. "Does anyone wish to qualify to bid?" One or more people may wish to bid. The person conducting the sale will talk to each bidder separately and actually check the bidder's funds and note the amount, the bidder's name and dollar amount. The amount shown is meaningless as long as it is higher than the opening bid. The opening bid may be \$181,545.76. To qualify, the bidder must have at least \$181,545.77.

As an example, an experienced buyer may show a \$200,000 check and bid no higher than \$182,000. On the other hand, they might qualify at \$182,000 and requalify (show more money) as the bidding goes higher.

The Trustee now "cries" the sale and announces "on behalf of the Beneficiary an opening bid of \$181,545.76." In the event there are no overbids, the Trustee cries the usual "going once, going twice, sold to the Beneficiary for \$181,545.76." If other bidders are present, the next bid will usually be + one penny. Heaven forbid that the pros would overbid by \$1.00 and waste 99 cents!

The person conducting the sale sets the pace. Finally, the property is “SOLD.” The person conducting the sale collects the money if the property was sold to an outside bidder, and gives them a receipt.

To complete the foreclosure process the Trustee now issues a Trustee’s Deed to the Beneficiary or outside bidder. In the case of an outside bidder, the Beneficiary is paid in full and the fees and costs are paid as the bid included these fees and costs. In the event of an overbid, junior lienholders are paid excess funds in order of priority as long as there are sufficient funds. Any remaining funds are remitted to the Trustor.

The foreclosure action extinguishes any *junior* lienholders and even the IRS (if properly notified). The IRS, however, has the right to “redeem the property” within 120 days.

CHART

1st Trust Deed	\$105,000	Recorded 8/17/73	Unpaid balance now \$58,488
2nd Trust Deed	\$40,000	Recorded 12/14/94	Unpaid balance now \$25,550
3rd Trust Deed	\$25,000	Recorded 1/15/95	Unpaid balance now \$24,000
4th Trust Deed	\$20,000	Recorded 3/15/95	Unpaid balance now \$20,000
Real Estate Taxes owed 1995, 1996, 1997			

NOD 2nd Trust Deed	4/11/97	
NTS (2nd Trust Deed)	7/15/97	\$26,985.70
Sale to outside bidder	8/14/97	\$31,000.00
Trustee’s Deed recorded		

New buyer takes title “subject to”

1. All unpaid real estate taxes
2. First Trust Deed

Buyer needs to contact 1st Trust Deed lender and make arrangements to pay off 1st Trust Deed or assume balance.

Balance of cash: (\$31,000 minus \$26,985.70) paid to 3rd Trust Deed holder
3rd Trust Deed holder partially wiped out
4th Trust Deed holder completely wiped out.

In some cases, wiped out junior trust deed holders can sue in court on their now-unsecured promissory note.

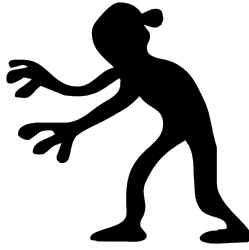

THE FORTY THIEVES

This is a term that has been common for decades. There is a group of professional “sale chasers” who make a very good living dealing in foreclosure properties. This is a broad area. These “bottom feeders” work during the curing period or purchase the property at the actual sale.

Some examples of these dealings with the property owner after the filing of an NOD:

1. “I’ll give you \$500 for a Quit Claim--You are going to lose it anyway.”
2. “Deed the property to me. I’ll refi and sell it back to you.”
3. “Deed the property to me. I’ll cure the default and rent back to you.”
4. “Deed your rental property to me and I’ll cure your default and save your credit. Remember to pay me the security deposits.”

Some examples at the sale are:

1. “You’re a nice couple. Pay me \$500 and I won’t bid on the Maple Street house.”
2. “Give me \$5,000 and I’ll bid on the property for you and sell it back to you.”
3. Actually buy the property and resell it at a profit.

Foreclosure laws were amended almost 20 years ago to counter some of the homeowner ripoffs outlined above. Foreclosure consultants laws were enacted to make it unlawful to take “unconscionable advantage” of a homeowner in foreclosure.

Before those laws, beneficiaries were able to postpone sales at will. Now posting and publishing of the Notice of Trustee’s Sale must be started all over again if the beneficiary postpones the sale more than three times. This was necessitated because of a somewhat humorous scam. Let’s assume that an unscrupulous beneficiary had a \$10,000 first trust deed on a \$50,000 house in foreclosure. They didn’t want to be paid off by an outside bidder; they wanted to steal the property. Since the sale can be held anywhere in the same county as the property, Catalina goat pastures became the place of choice for crooked beneficiaries. If outside bidders came to Catalina the sale was postponed continuously until nobody else showed up. Then the property would be “sold to the beneficiary” -- no outside



bidders.

Trustee's Deed p 1

97 1346565

RECORDING REQUESTED BY

OLD REPUBLIC TITLE COMPANY

AND WHEN RECORDED MAIL TO:

Foothill Conveyance Corp.
3450 N. Verdugo Road
Glendale, CA 91208

RECORDED/FILED IN OFFICIAL RECORDS
RECORDER'S OFFICE
LOS ANGELES COUNTY
CALIFORNIA
AUG 29 1997 AT 8 A.M.

FEE \$10 F
DAF \$2
C-20 2-

SPACE ABOVE THIS LINE FOR RECORDER'S USE

NOTICE OF TRUSTEE'S SALE

NO. FCC 2588

YOU ARE IN DEFAULT UNDER A DEED OF TRUST DATED December 18, 1995
UNLESS YOU TAKE ACTION TO PROTECT YOUR PROPERTY, IT MAY BE SOLD AT A PUBLIC SALE. IF
YOU NEED AN EXPLANATION OF THE NATURE OF THE PROCEEDING AGAINST YOU, YOU SHOULD
CONTACT A LAWYER.

On September 23, 1997, at 11:00A.M., FOOTHILL CONVEYANCE CORPORATION, a
California Corporation, as duly appointed Trustee under and pursuant to Deed of Trust recorded January 23, 1996
as Instrument No. 96-124055, Book, Page, of Official Records, executed by:

JOHN BORROWER AND MARY BORROWER, HUSBAND AND WIFE AS COMMUNITY PROPERTY

as Trustor(s), in the office of the County Recorder of Los Angeles County, State of
California, WILL SELL AT PUBLIC AUCTION TO HIGHEST BIDDER FOR CASH, payable at time of sale in lawful
money of the United States (in the forms which are lawful tender in the United States) and/or cashier's, certified or other
checks specified in Civil Code Section 2924h (payable in full at the time of sale).

AT: the front entrance to the Los Angeles County Courts Building
12720 Norwalk Blvd., Norwalk, CA 90650

all right, title and interest conveyed to and now held by it under said Deed of Trust in the property situated in said County
and State described as:

AS PER EXHIBIT "A" ATTACHED HERETO AND MADE A PART HEREOF

The street address and other common designation if any, of the real property described above is purported to be:
10149 Commerce Avenue, Unit #28, Tujunga, CA 91042 APN 2565-013-087

The undersigned Trustee disclaims any liability for any incorrectness of the street address and other common
designation, if any, shown herein.

Said sale will be made, but without covenant or warranty, express or implied, regarding title, possession, or
encumbrances, to pay the remaining principle sum of the note(s) secured by said Deed of Trust, with interest thereon, as
provided in said note(s), advances, if any, under the terms of said Deed of Trust, fees, charges and expenses of the Trustee
and of the trusts created by said Deed of Trust, for the amount reasonably estimated to be \$ 54,487.08

The beneficiary under said Deed of Trust heretofore executed and delivered to the undersigned a written
Declaration of Default and Demand for Sale, and a written Notice of Default and Election to Sell. The undersigned
caused said Notice of Default and Election to Sell to be recorded in the county where the real property is located.

Date: August 28, 1997

FOOTHILL CONVEYANCE CORPORATION, As said Trustee

Dorene Kessinger, Secretary
Address 3450 North Verdugo Road, Glendale, CA 91208
Telephone Number (818)248-0000

Trustee's deed p 2

EXHIBIT "A"

A CONDOMINIUM COMPRISED OF:

PARCEL 1:

(A) AN UNDIVIDED 1/28 INTEREST IN LOT 1 OF TRACT NO. 28294, IN THE CITY OF LOS ANGELES, COUNTY OF LOS ANGELES, STATE OF CALIFORNIA, AS PER MAP RECORDED IN BOOK 1023 PAGES 97 AND 98 OF MAPS, IN THE OFFICE OF THE COUNTY RECORDER OF SAID COUNTY.

EXCEPT UNITS 1 TO 28 INCLUSIVE AS SHOWN AND DEFINED ON THE CONDOMINIUM PLAN RECORDED AUGUST 10, 1984 AS INSTRUMENT NO. 84-960578 IN SAID OFFICE OF THE COUNTY RECORDER.

(B) UNIT 28, AS SHOWN AND DEFINED ON THE CONDOMINIUM PLAN REFERRED TO ABOVE.

97-1480542

LIFE AFTER FORECLOSURE-- **ARE YOUR REAL ESTATE DAYS OVER?**

NO!

Fortunes have been made in real estate. The typical homeowner has traditionally built up a substantial portion of their net worth just by owning their own home. Don't give up because of a foreclosure.

Lease Option

This is the easiest, most available way to "come back." Don't be too choosy; remember, location, LOCATION, *LOCATION*. Try for 2-3 years; you do not have to exercise the option to make \$\$\$\$. There are many ways to pay for the option.

Seller Carry Back

You can purchase another home the day after foreclosure. Yes, you really can. Find a way to offer them a decent down payment or use some common creative financing techniques.

Hard Money Loans

Do you have a good down payment or will the seller carry back a second trust deed with very little down? A hard money lender will easily lend you 60-75% of the purchase price. The purchase has to be "under market" to absorb the higher interest rate.

Equity Sharing (Mouse and Elephant)

The real estate market is making a strong comeback and this option is again available. Lock in a great deal and find a financial partner to arrange 100% of the financing. Using this arrangement, you will live in the property (if single family) and sell or refi in 3-5 years. The profits are then split. Find the elephant through the classified ads.

BONUS SECTION

(Making Money With Foreclosure Properties)



MAKING MONEY WITH FORECLOSURE PROPERTIES

Buying at the actual sale

This is *not* for novice real estate investors. Buy a property or two on more conventional terms to gain real estate experience. If you have experience and financial backing, follow ten NOD's all the way to sale and actually attend the sales for experience. If you take this advice you will do a lot of legwork and discover that you would have only had a chance to acquire one or two properties. I said only a chance. If you're still ready after ten dry runs, pick out another ten properties; this is the real thing. You will discover this is not a part time job. Be prepared for last minute payoffs, bankruptcies and multiple postponements. You now realize how frustrating and expensive it is to attend sale after sale with \$50,000-\$100,000 in cashier's checks, only to hear the words, "Postponed due to..."

Make a good title company contact. Better yet, take on a partner with experience in buying foreclosure properties or title company experience.

If you don't have the stomach for all-cash offers, attend the sale and make an offer to the top bidder:

- a) If one of the 40 thieves acquires the property at sale, a quick turnover would be okay. Make an offer to repurchase the property.
- b) If a bank lender acquires the property (REO), contact them immediately and make an offer.
- c) If a private party lender acquires the property due to no overbids, they will be very receptive to your offer and they will usually offer great financing.

Purchasing the Trust Deed before the sale

Many lenders will sell the trust deed at a discount while it is in foreclosure. This also requires "all cash" but is a great way to acquire a property. For instance, a lender may have a \$200,000 note on a property valued at \$220,000. The note and trust deed are purchased for \$172,000 and you take the place of the original lender. When the property goes to sale you will either own the property or be paid off by an outside bidder at the sale. You will either get the property or \$200,000 for your \$172,000 investment.

**The most important point:
YOU ARE A LAMB.
A TRUSTEE'S SALE CAN BE A SLAUGHTER.**

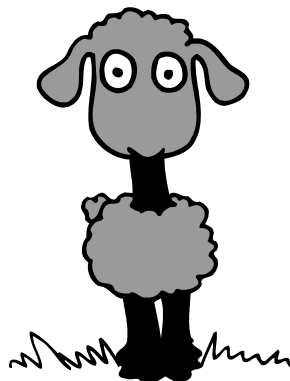

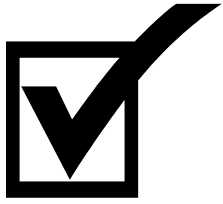

SALE CHECK LIST

Remember, this is a very risky business. *Do your homework* and then keep your fingers crossed.

Are you sure the property is in good condition and doesn't need thousands of dollars in repairs? Leave ample room in your bid to cover many unexpected repairs.

Are you sure this is a first trust deed? Check title for subordination agreements. If this is a second or third, what is the status of the senior trust deeds?

1. Due dates on senior trust deeds
2. Delinquencies on senior trust deeds
3. Due on sale clauses on senior trust deeds

How much are the real estate tax delinquencies? Remember, *they are senior even to the first trust deed.*

How about federal tax liens? Remember, *the IRS can redeem the property for 120 days.*

If the property is occupied, how long will it take you to evict the occupants and how much will it cost? If the occupant is a tenant, check for *rent control and leases.*

Check **priority** again--This is a bidder's worst nightmare.

Check title chain and compare ownership against names on the deed of trust. This sale could be a partial ownership only.



SOURCES OF FOR BUYING FORECLOSURE PROPERTY AT THE SALE

1. Take out an "equity line of credit" on your home. This can be the best bet because you can withdraw the money and redeposit it repeatedly with just a daily interest charge.
2. Borrow money against stocks and bonds at a low rate.
3. Convince a parent, friend or relative to finance your first purchase. If you are the successful bidder you can then quickly refinance the property.
4. Arrange the financing with an equity lender. The lender will usually take the property in their name and then resell it to you with a profit. This can be very expensive due to the postponements often encountered. The lender will charge to attend the sale and charge for the use of the money even if the sale is canceled or postponed.

- 
5. Offer a percent of equity ownership to a financial partner with a SAM (shared appreciation mortgage). This type of financing includes interest at a reasonable rate *and* a share in the profits.

THE END



I will be happy to answer your real estate questions
or at least refer you to the best sources.

PETER ROSENTHAL
THE V.I.P. GROUP
3450 North Verdugo Road, Glendale 91208
Telephone (818)248-0000
Facsimile (818)248-3296

NOTE PAPER