

Your  
Institution  
Logo Here

**Audience Banner Here**

Your  
Division  
Logo Here

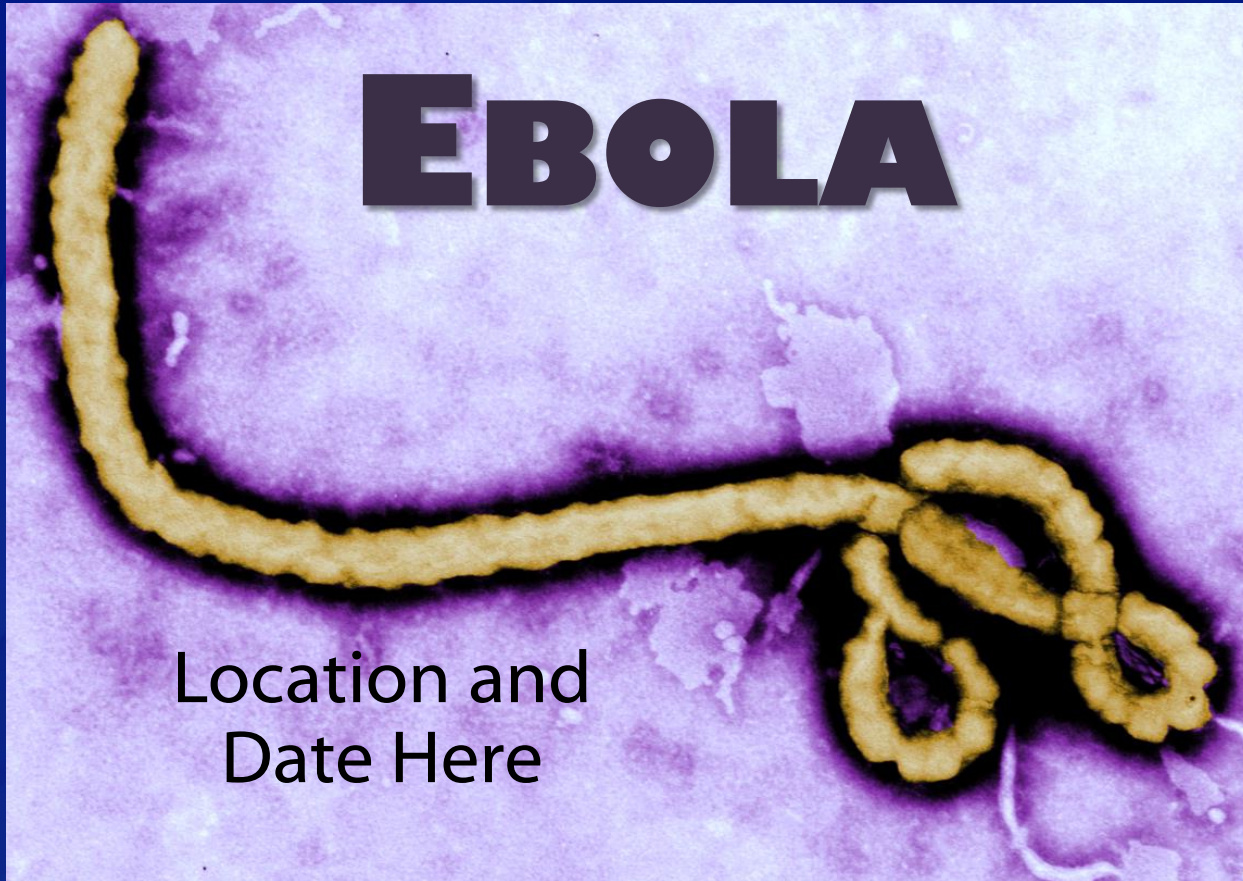

# 2014 Ebola Outbreak, West Africa

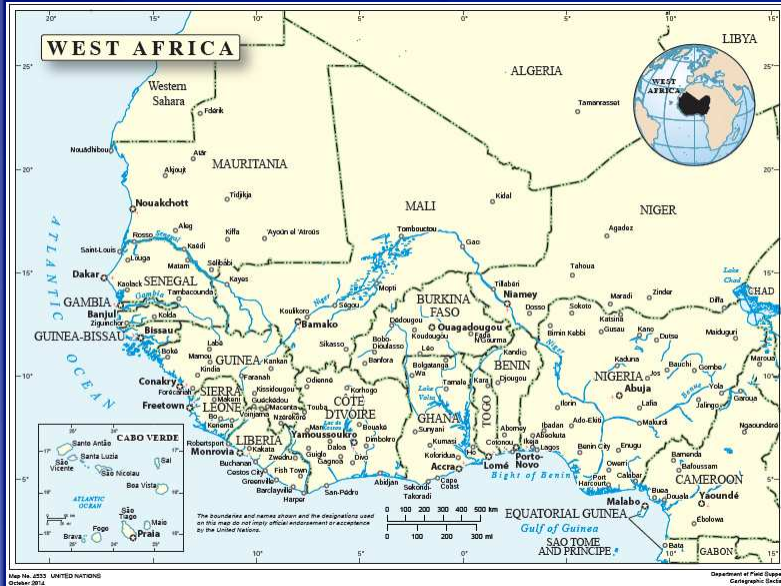

- ❑ This is the largest Ebola outbreak in history and the first Ebola epidemic the world has ever known.
- ❑ CDC's response to Ebola is the largest international outbreak response in CDC's history.

Source: United Nations:

<http://www.un.org/Depts/Cartographic/map/profile/westafrika.pdf>

Maps that incorporate the latest information on the 2014 Ebola outbreak in West Africa can be found at:

<http://www.cdc.gov/vhf/ebola/resources/distribution-map-guinea-outbreak.html>

## Outbreak Challenges

- ❑ **Overburdened public health and healthcare systems**
  - **Unpaid healthcare workers**
  - **Insufficient treatment centers, beds, medical supplies, and personal protective equipment (PPE)**







## Outbreak Challenges

- ❑ **Inefficient use of stakeholders**
  - Backlog of data cleaning and entry
  - Need for complete data
  - Need to report suspected cases instead of waiting for lab confirmation

## Ebola Outbreak, West Africa

- On August 8, the World Health Organization (WHO) declared that the current Ebola outbreak is a Public Health Emergency of International Concern (PHEIC)

WEST AFRICA  
**Ebola Outbreak**



**1st Ebola outbreak in West Africa**  
Multiple countries:

- Guinea
- Liberia
- Nigeria
- Senegal
- Sierra Leone

**Likely host = bats**

**1 in 2**  
people who get Ebola in this outbreak have died.

- The PHEIC declaration underscores the need for a coordinated international response to contain the spread of Ebola

## Outbreak Challenges, West Africa

- ❑ Porous borders
- ❑ High population mobility
- ❑ Geographic breadth



# Outbreak Challenges: Lack of acceptance of Ebola

- ❑ Not overcome by education
- ❑ Fear and superstition
  - Health posters
- ❑ Stigma
  - Needing to share negative test results to return to work
- ❑ Distrust of outsiders
  - Brought Ebola to make money
- ❑ Role of war exposure

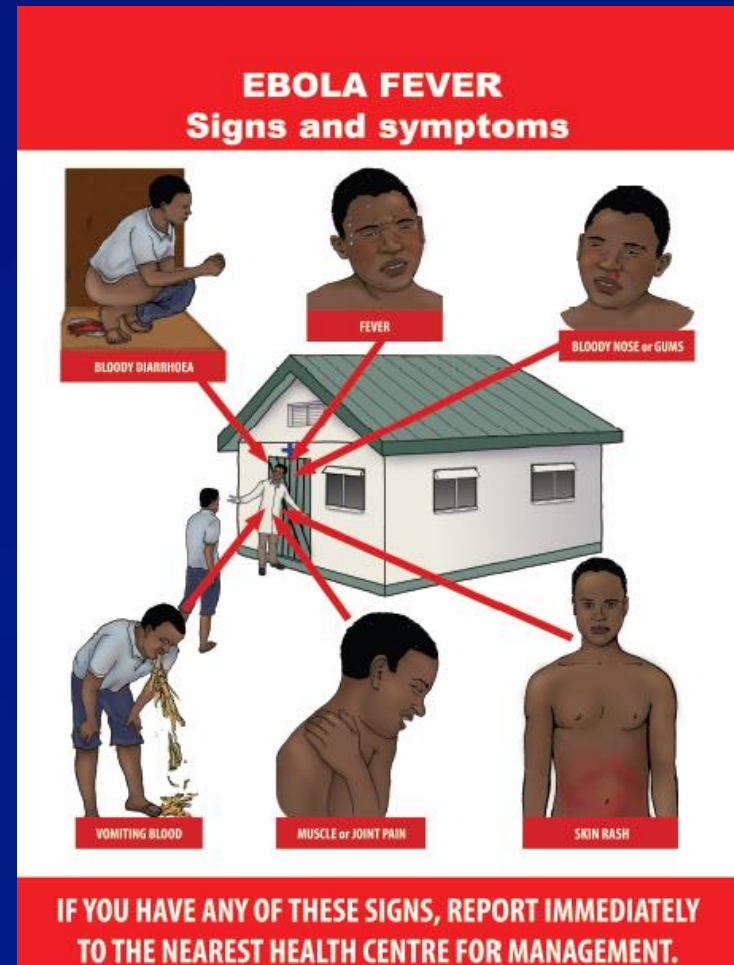

# Overall Goals in Outbreak Response

1. **Patient Care**
  - Experienced and/or trained staff
  - Strict use of personal protective equipment (PPE)
2. **Stop human to human transmission**
  - Case identification
  - Contact tracing
  - Infection control





# Overall Goals in Outbreak Response

## 3. Community education

- Text messages, radio and video messages in local languages, fact sheets, health posters and pamphlets

<p><b>Facts <i>about</i> Ebola</b></p> <p>You can't get Ebola through air</p> 	<p><b>Faits <i>concernant</i> le virus Ebola</b></p> <p>Vous ne pouvez pas être atteint(e) par le virus Ebola par le biais de l'air</p> 	<p><b>Información <i>sobre</i> el virus del Ébola</b></p> <p>Usted no puede contraer el virus del Ébola por el aire</p> 			
<p>You can't get Ebola through water</p> 	<p>You can't get Ebola through food</p> 	<p>Vous ne pouvez pas être atteint(e) par le virus Ebola par le biais de l'eau</p> 	<p>Vous ne pouvez pas être atteint(e) par le virus Ebola par le biais de l'alimentation</p> 	<p>Usted no puede contraer el virus del Ébola por el agua</p> 	<p>Usted no puede contraer el virus del Ébola por los alimentos</p> 
<p><a href="#">Facts About Ebola Infographic (English)</a></p> <p> [PDF - 1 page]</p>	<p><a href="#">Facts About Ebola Infographic (French)</a></p> <p> [PDF - 1 page]</p>	<p><a href="#">Facts About Ebola Infographic (Spanish)</a></p> <p> [PDF - 1 página]</p>			

[Listen to Ebola radio health messages in local languages.](#)

**BACKGROUND**

# Ebola is a rare and deadly disease.

- First discovered in 1976 near the Ebola River in the Democratic Republic of the Congo
- Outbreaks occur sporadically in Africa
- Family of zoonotic RNA viruses
  - Filoviridae



E. Ervin, CDC/USPH, 2014

EBOLAVIRUS OUTBREAKS BY SPECIES AND SIZE, 1976 - 2014

Species	Number of Cases
Zaire ebolavirus	1 - 10
Sudan ebolavirus	11 - 100
Tai Forest ebolavirus	101 - 425
Bundibugyo ebolavirus	



# Ebola Virus Disease

- Previously called Ebola hemorrhagic fever
- 5 species of *Ebolavirus*
  - *Zaire ebolavirus*
  - *Bundibugyo ebolavirus*
  - *Reston ebolavirus*
  - *Sudan ebolavirus*
  - *Tai Forest ebolavirus*
- All but *Reston ebolavirus* known to cause disease in humans
- Death rates for Ebola range from 50%-90%

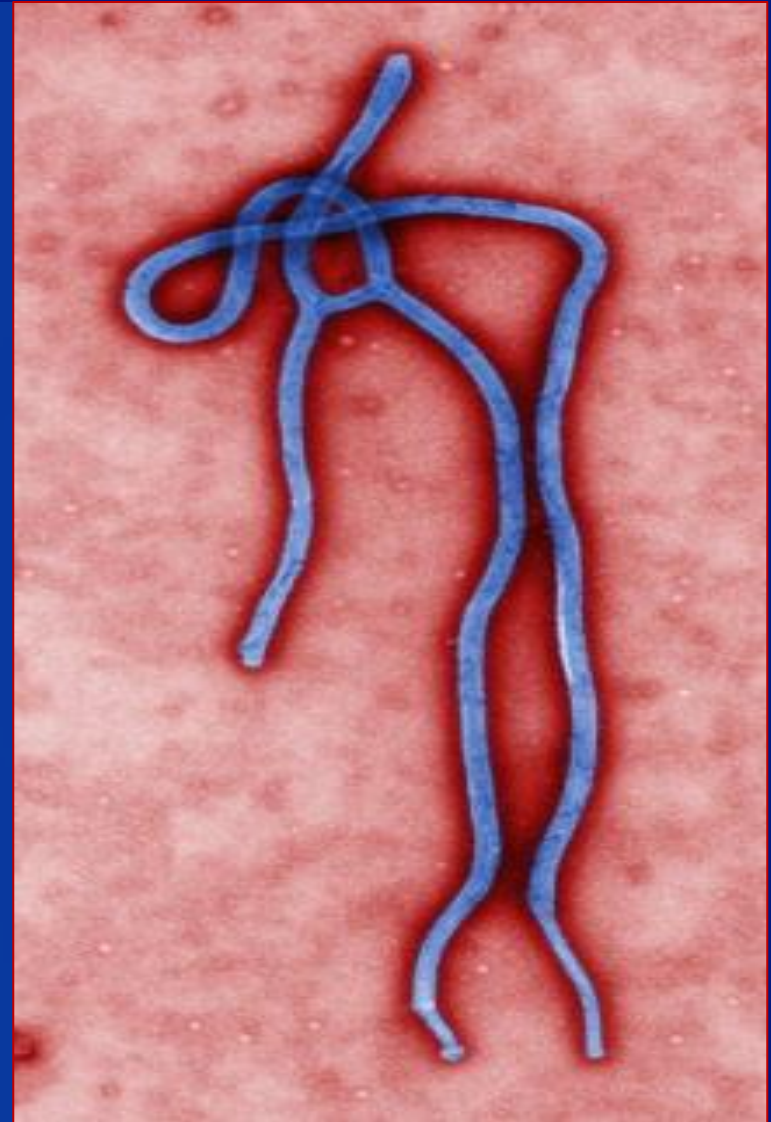

# Ebolavirus Ecology

## Enzootic Cycle

New evidence strongly implicates bats as the reservoir hosts for ebolaviruses, though the means of local enzootic maintenance and transmission of the virus within bat populations remain unknown.

### Ebolaviruses:

- Ebola virus (formerly Zaire virus)
- Sudan virus
- Tai Forest virus
- Bundibugyo virus
- Reston virus (non-human)

## Epizootic Cycle

Epizootics caused by ebolaviruses appear sporadically, producing high mortality among non-human primates and duikers and may precede human outbreaks. Epidemics caused by ebolaviruses produce acute disease among

humans, with the exception of Reston virus which does not produce detectable disease in humans. Little is known about how the virus first passes to humans, triggering waves of human-to-human transmission, and an epidemic.

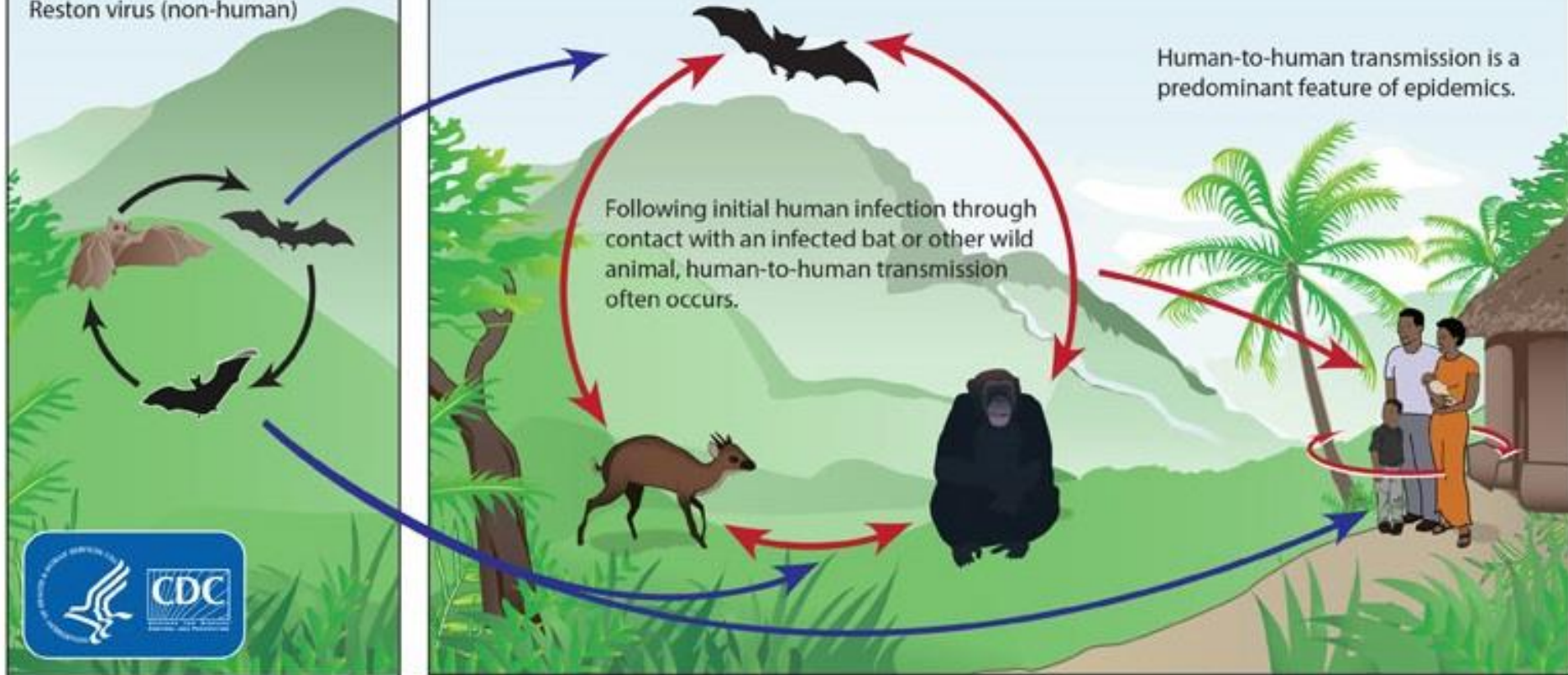

## **Transmission**

- ❑ **Ebola virus is spread through direct contact (through broken skin or unprotected mucous membranes) with:**
  - A sick person's blood or body fluids, including but not limited to urine, saliva, feces, vomit, and semen
  - Contaminated objects (like needles and syringes)
  - Infected animals (by contact with their blood, fluids, or infected meat)
- ❑ **Ebola virus has been detected in breast milk, but it is not known if the virus can be transmitted from mothers to infants through breastfeeding**

# Human to Human Transmission

## ❑ Two main points:

- First, a person is infectious WHEN they are symptomatic.
- Second, there are control measures which can prevent exposures infectious body fluids and contaminated objects (like needles and syringes)

## ❑ Infectious body fluids:

(time ranges are approximate)

- Viremia/blood ~1-23 days
- Saliva/Swab ~1-11 days
- Urine ~1-25 days
- Tears/Conj. ~ 1-25 days
- Semen ~17-105 days
- Sweat ~1-10 days
- Vaginal ~21-58 days
- Rectal/Feces
- Milk ~13-18 days

# Symptoms

## ❑ Signs of Ebola include fever symptoms such as:

- Severe headache
- Muscle pain
- Vomiting
- Diarrhea
- Abdominal pain
- Unexplained hemorrhage

## ❑ The incubation period, from exposure to when signs or symptoms appear, is 2 to 21 days, but the average time is 8 to 10 days.

- A person infected with Ebola virus is not contagious until symptoms appear.





## Prevention

- ❑ **There is no FDA-approved vaccine available for Ebola**
- ❑ **If you must travel to or are in an area affected by the Ebola outbreak, make sure to do the following:**
  - Practice careful hygiene
    - Wash your hands frequently with soap and water or an alcohol-based hand sanitizer
  - Avoid contact with blood and body fluids
    - Such as urine, saliva, feces, vomit and semen
  - Do not handle items that may have come in contact with an infected person's blood or body fluids
    - Such as needles or other medical equipment
  - Avoid funeral or burial rituals that require handling the body of someone who has died from Ebola

## Prevention, cont.

- ❑ **If you must travel to or are in an area affected by the Ebola outbreak, make sure to do the following:**
  - Avoid contact with bats and nonhuman primates or blood, fluids, and raw meat prepared from these animals
  - Avoid hospitals in West Africa where Ebola patients are being treated
    - The U.S. Embassy or consulate is often able to provide advice on healthcare facilities
  - Seek medical care immediately if you develop fever, headache, muscle pain, diarrhea, vomiting, stomach pain, or unexplained bruising or bleeding
    - Tell your doctor about your recent travel and your symptoms before you go to the office or emergency room
    - Limit your contact with other people when you go to the doctor. Do not travel anywhere else.

# Laboratories

- ❑ CDC has developed **interim guidance** for laboratory workers and other healthcare personnel who collect or handle specimens in the United States
- ❑ This guidance includes information about the appropriate steps for collecting, transporting, and testing specimens from patients who are suspected to be infected with Ebola virus.

INTERIM GUIDANCE FOR  
Specimen Collection, Transport, Testing, and Submission  
for Patients with Suspected Infection with Ebola Virus Disease

NOTIFICATION & CONSULTATION

Hospitals should follow their state and/or local health department procedures for notification and consultation for Ebola testing requests before contacting CDC. CDC cannot accept any specimens without prior consultation.

FOR CONSULTATION, CALL THE EMERGENCY OPERATIONS CENTER AT 770-488-7100

WHEN SPECIMENS SHOULD BE COLLECTED FOR EBOLA TESTING

Ebola virus is detected in blood only after onset of symptoms, most notably fever. It may take up to three days after onset of symptoms for the virus to reach detectable levels. Virus is generally detectable by real-time RT-PCR between 3 to 10 days after onset of symptoms.

Ideally, specimens should be taken when a symptomatic patient reports to a healthcare facility and is suspected of having an Ebola virus exposure. However, if the onset of symptoms is less than three days after potential exposure, a subsequent specimen will be required to rule out Ebola.

3 days

PREFERRED SPECIMENS FOR EBOLA TESTING

A minimum volume of 4 milliliters of whole blood preserved with EDTA, clot activator, sodium polyanethanol sulfonate (SPS), or citrate in plastic collection tubes can be submitted for Ebola virus disease testing.

Specimens should be shipped at 4°C. Do not submit specimens to CDC in glass containers. Do not submit specimens preserved in heparin tubes.

Specimens other than blood may be submitted upon consult with the CDC.

Standard labeling should be applied for each specimen. The requested test needs to be identified only on the requisition and CDC specimen submission forms.

4°C

DIAGNOSTIC TESTING FOR EBOLA PERFORMED AT CDC

Several diagnostic tests are available for detection of Ebola virus disease. Acute infections will be confirmed using a real-time RT-PCR assay (CDC test directory code CDC-10309 Ebola Identification) in a CLIA-accredited laboratory. Virus isolation may also be attempted. Serologic testing for IgM and IgG antibodies will be completed for certain specimens and to monitor the immune response in confirmed Ebola virus disease patients (CDC-10310 Ebola Serology).

Lassa fever is also endemic in certain areas of West Africa and may show symptoms similar to early Ebola virus disease. Diagnostic tests including but not limited to RT-PCR, antigen detection, and IgM serology may be utilized to rule out Lassa fever in patients who test negative for Ebola virus disease.

TRANSPORTING SPECIMENS WITHIN THE HOSPITAL/ INSTITUTION

In compliance with 29 CFR 1910.1030, specimens should be placed in a durable, leak-proof secondary container for transport within a facility. To reduce the risk of breakage or leaks, do not use any pneumatic tube system for transporting specimens from a patient with suspected Ebola virus disease.

PACKAGING & SHIPPING CLINICAL SPECIMENS TO CDC

Specimens collected for Ebola virus disease testing should be packaged and shipped without attempting to open collection tubes or aliquot specimens.

Specimens for shipment should be packaged following the basic triple packaging system, which consists of a primary receptacle (a sealable specimen bag) wrapped with absorbent material, secondary receptacle (watertight, leak-proof), and an outer shipping package.

THE SUBMISSION PROCESS

Contact your state and/or local health department and CDC (770-488-7100) to determine the proper category for shipment based on clinical history and risk assessment by CDC and to obtain detailed shipping guidance and required CDC submission documents. State guidelines may differ and state or local health departments should be consulted before shipping.

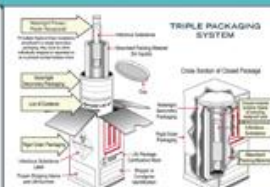

## Collecting Ebola Specimens

- ❑ All laboratory workers and other healthcare personnel who collect or handle specimens should follow established standards that are compliant with the OSHA bloodborne pathogens standard, which encompasses blood and other potentially infectious materials
  - These standards include wearing appropriate personal protective equipment (PPE) and use of a certified class II Biosafety cabinet or Plexiglass splash guard, as well as manufacturer-installed safety features for instruments



## **Shipping Ebola Specimens**

- ❑ CDC recommends that U.S. healthcare workers contact their state and/or local health department and CDC to determine the proper category for shipment of clinical specimens based on clinical history and risk assessment by CDC**
- ❑ No specimens should be shipped to CDC without consultation with CDC and local/state health departments**

# Shipping Ebola Specimens

## □ Ebola specimens should be packaged following the basic triple packing system consistent with International Air Transport Association Category A guidelines

- This packing system consists of a primary non-breakable receptacle wrapped with absorbent material, secondary receptacle (watertight, leak-proof), and an outer shipping package.

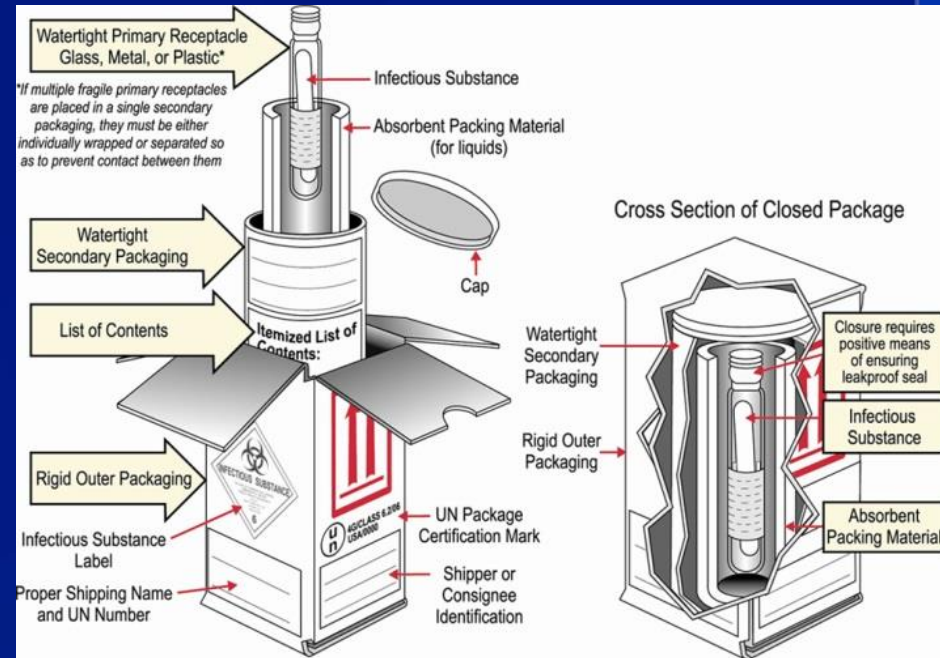

## Laboratory Testing Specimens

- ❑ **Ebola virus is detected in blood only after onset of symptoms, most notably fever**
  - It may take up to 3 days post-onset of symptoms for the virus to reach detectable levels
  - Virus is generally detectable by real-time RT-PCR between 3 to 10 days post-onset of symptoms, but has been detected for several months in certain secretions (e.g., semen)
  - Specimens ideally should be taken when a symptomatic patient seeks care and is suspected of having an Ebola exposure; however, if the onset of symptoms is less than 3 days, a subsequent specimen will be required to completely rule-out Ebola

# Treatment

- ❑ **No FDA-approved vaccine or medicine (e.g., antiviral drug) is available for Ebola**
- ❑ **Symptoms of Ebola are treated as they appear. The following basic interventions, when used early, can significantly improve the chances of survival**
  - Providing intravenous fluids and balancing electrolytes (body salts)
  - Maintaining oxygen status and blood pressure
  - Treating other infections if they occur
- ❑ **Experimental vaccines and treatments for Ebola are under development, but they have not yet been fully tested for safety or effectiveness**



## **Patient Recovery**

- ❑ Recovery from Ebola depends on good supportive care and the patient's immune response**
- ❑ People who recover from Ebola infection develop antibodies that last for at least 10 years, and possibly longer**
- ❑ It isn't known if people who recover are immune for life or if they can become infected with a different species of Ebola**
- ❑ Some people who have recovered from Ebola have developed long-term complications (joint and muscle pain, and vision problems)**

# Ebola Virus Disease Case Definition

## □ Person Under Investigation

- Fever (>38.6°C or 101.5°F)
- AND symptoms
- AND epidemiologic risk factors within past 21 days prior to symptom onset

## □ Probable Case

- Person Under Investigation
- AND low risk exposure OR high risk exposure

## □ Confirmed Case

- A case with laboratory-confirmed diagnostic evidence of Ebola virus infection

### Symptoms

- Severe headache
- Muscle pain
- Vomiting
- Diarrhea
- Abdominal pain
- Unexplained hemorrhage

## **Risk**

- ❑ **Healthcare workers caring for Ebola patients and the family and friends in close contact with Ebola patients are at the highest risk of getting sick because they may come in contact with the blood or body fluids of sick patients**
- ❑ **People also can become sick with Ebola after coming in contact with infected wildlife.**
  - In Africa, Ebola may be spread as a result of handling bushmeat (wild animals hunted for food) and contact with infected bats

# Healthcare Providers in the United States

- ❑ **CDC encourages all U.S. healthcare providers to:**
  - Ask patients about their travel histories to determine if they have traveled to West Africa within the last three weeks
  - Know the signs and symptoms of Ebola – fever (greater than 101.5°F or 38.6°C), severe headache, muscle pain, vomiting, diarrhea, abdominal (stomach) pain, or unexplained hemorrhage (bleeding or bruising)
  - Know what to do if they have a patient with Ebola symptoms:
    - First, properly isolate the patient
    - Then, follow infection control precautions to prevent the spread of Ebola. Avoid contact with blood and body fluids of infected people

## Healthcare Providers in the United States

- ❑ **U.S. healthcare workers should follow CDC's "Infection Prevention and Control Recommendations for Hospitalized Patients with Known or Suspected Ebola Hemorrhagic Fever in U.S. Hospitals"**
  - CDC recommends standard, contact, and droplet precautions for management of hospitalized patients with known or suspected Ebola
    - These precautions can be found in "2007 Guideline for Isolation Precautions: Preventing Transmission of Infectious Agents in Healthcare Setting" at [www.cdc.gov/hicpac/2007IP/2007ip\\_part3.html](http://www.cdc.gov/hicpac/2007IP/2007ip_part3.html)
  - Any U.S. hospital that is following CDC's infection control recommendations and can isolate a patient in a private room is capable of safely managing a patient with Ebola virus disease

# Infection Control

## □ Early recognition

- Early recognition is critical for infection control

## □ Patient Placement

- Patients should be placed in a single patient room containing a private bathroom with the door closed
- Only use a mattress and pillow with waterproof plastic or other waterproof covering

## □ Protecting healthcare providers

- All people entering the patient room should at least wear: gloves, gown (fluid resistant or impermeable), eye protection (goggles or face shield) and a facemask
- Healthcare providers should frequently perform hand hygiene before and after all patient contact, contact with potentially infectious material, and before putting on and upon removal of PPE, including gloves

## **Environmental Infection Control**

- ❑ **Daily cleaning and disinfection of hard, non-porous surfaces should be done using a U.S. Environmental Protection Agency (EPA)-registered hospital disinfectant with a label claim for a non-enveloped virus**
- ❑ **Staff performing environmental cleaning and disinfection should wear recommended PPE and consider the use of additional barriers (e.g., shoe and leg coverings)**
  - Eye protection (face shield or goggles) and face mask should be worn when performing tasks such as liquid waste disposal that can generate splashes

## Patient Care

- ❑ **Dedicated medical equipment (preferably disposable) should be used for patient care**
- ❑ **All non-dedicated, non-disposable medical equipment used for patient care should be cleaned and disinfected according to the manufacturer's instructions and hospital policies**
- ❑ **Limit the use of needles and other sharps as much as possible**
  - All needles and sharps should be handled with extreme care and disposed in puncture-proof , sealed containers



# U.S. Travelers to West Africa



- ❑ **CDC has issued Warning, Level 3 travel notice for 3 countries**
  - U.S. citizens should avoid nonessential travel to Guinea, Liberia, and Sierra Leone
- ❑ **CDC has issued an Alert, Level 2 travel notice for Nigeria**
  - Travelers to Nigeria should take enhanced precautions to prevent Ebola
- ❑ **If you travel to any of the affected countries, pay attention to your health after you return**
  - Monitor your health for 21 days if you were in an area with an Ebola outbreak

## **Travel to Affected Countries**

- ❑ **Practice careful hygiene. Avoid contact with blood and body fluids**
  - Do not handle items that have come in contact with an infected person's blood or body fluids
  - Avoid funeral or burial rituals that require handling the body of someone who has died from Ebola
  - Avoid contact with animals or raw meat
  - Avoid hospitals where patients with Ebola are being treated
  
- ❑ **Pay attention to your health after you return**
  - Monitor your health for 21 days
    - During the time that you are monitoring your health, you can continue your normal activities, including work

# Monitoring and Movement of People with Ebola

- ❑ **CDC has created guidance for monitoring people exposed to Ebola and for evaluating their travel, including the application of movement restrictions when indicated**
  - **Conditional release**—people are monitored by a public health authority for 21 days after the last known Ebola virus exposure. People conditionally released should self-monitor for fever twice daily and notify the public health authority if they develop fever or other symptoms.
  - **Controlled movement**—requires people to notify the public health authority about their intended travel for 21 days after their last known potential Ebola virus exposure. They should not travel on commercial flights, ships, long-distance buses, or trains.