

Submittal specification for 120 kA SPD Series sidemount versions

Eaton's SPD Series Surge Protective Devices (SPD) are used to protect equipment from damage caused by surge events. This submittal specification represents sidemount versions of the SPD Series units with a catalog number beginning with "SPD120." These versions are designed to be mounted external to electrical distribution assemblies and interfaced via conduit and wires.

Table 1. Surge Current Capacity

Configuration	Per Phase	L-N Mode	L-G Mode	N-G Mode	L-L Mode
Single split phase (3W+G)	120	60	60	60	—
Three-phase wye (4W+G)	120	60	60	60	—
Three-phase delta (3W+G)	120	—	60	—	60
Three-phase high-leg delta (4W+G)	120	60	60	60	—

Table 2. Catalog Numbering System

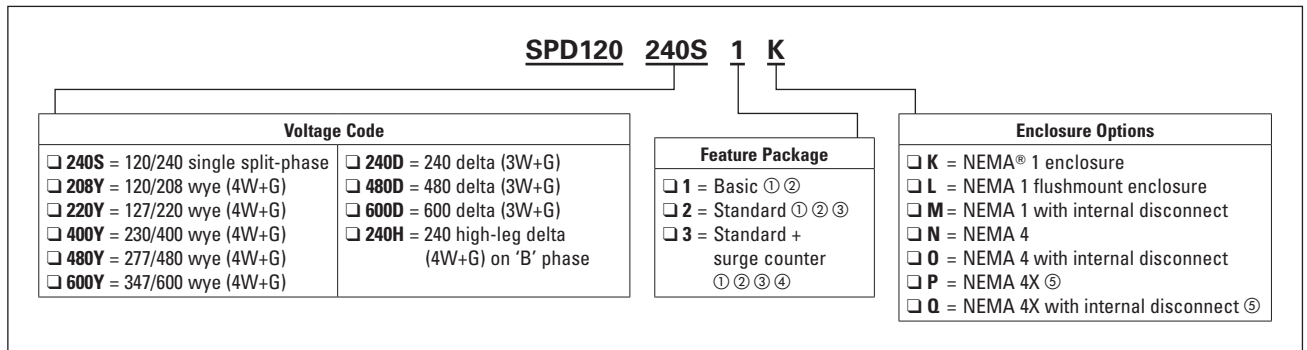

① Dual-colored LED per phase to indicate protection status.

② Dual-colored LED to indicate protection status of the N-G mode on units with a neutral wire.

③ Audible alarm with silence button, Form C relay contact, EMI/RFI filtering providing up to 50 dB of noise attenuation from 10 kHz to 100 MHz.

④ Surge counter with Reset button.

⑤ Constructed of 304 stainless steel.

Performance Specifications and Features

A. ANSI/UL® 1449 3rd Edition Voltage Protection Rating (VPR)

- a. VPR for units containing the basic feature package in a NEMA 1 enclosure without an internal disconnect (catalog number ends with 1K or 1L). For all other VPR values, please refer to Technical Data TD01005025E or insert Voltage Code and VPR Value in the fields below **Table 3**.

Table 3. Voltage Code and VPR

Voltage Code	VPR for Each Protection Mode			
	L-N	L-G	N-G	L-L
240S	700	700	700	1200
208Y and 220Y	700	700	700	1200
400Y and 480Y	1200	1200	1200	2000
600Y	1500	1500	1200	2500
240D	N/A	1000	N/A	1000
480D	N/A	2000	N/A	2500
600D	N/A	2500	N/A	2500
240H	700	700	700	1200

Enter VPR if not listed

Voltage Code	VPR for Each Protection Mode			
	L-N	L-G	N-G	L-L

- b. VPR for units containing the standard or standard with surge counter feature package in a NEMA 1 enclosure without an internal disconnect (catalog number ends with 2K, 2L, 3K, or 3L). For all other VPR values, please refer to Technical Data TD01005025E or insert Voltage Code and VPR Value in the fields below **Table 4**.



Table 4. Voltage Code and VPR

Voltage Code	VPR for Each Protection Mode			
	L-N	L-G	N-G	L-L
240S	600	800	600	1000
208Y and 220Y	600	800	600	1000
400Y and 480Y	1200	1200	1200	1800
600Y	1500	1500	1500	2500
240D	N/A	1000	N/A	1000
480D	N/A	2500	N/A	2500
600D	N/A	2500	N/A	2500
240H	700	800	700	1200

Enter VPR if not listed

Voltage Code	VPR for Each Protection Mode			
	L-N	L-G	N-G	L-L

- B. Internal overcurrent protection
 - a. All units contain thermally protected metal-oxide varistors. Each of these devices is internally fused by a thermal element that safely removes them from the circuit under abnormal conditions, such as temporary overvoltage or high fault current conditions.
- C. Monitoring and features (refer to **Table 2** for a listing of the individual features contained in each feature package)
- D. General features
 - a. Units with catalog numbers ending in K, L, or M contain a factory-installed 3/4-inch trade size chase nipple
 - b. Units with catalog numbers ending in N, O, P, or Q contain a factory-installed 3/4-inch trade size hub connector
 - c. All units are prewired at the factory. Phase, neutral, and ground connections are made via 10 AWG wires. Form C relay contact connections are made via 14 AWG wires ①
 - d. All units are factory sealed. No user intervention or internal connections are required
 - e. Units with an internal disconnect (catalog numbers ending in M, O, or Q) contain a three-pole, 30A thermal-magnetic circuit breaker, Eaton catalog number FDC3030
 - f. NEMA 1 and NEMA 4 enclosures are constructed of powder-coated steel
 - g. NEMA 4X enclosures are constructed of 304 stainless steel
- E. Enclosure dimensions and weights
 - a. NEMA 1 (catalog number ends with K): 10.50L x 7.50W x 3.50D inches, 6.8 lbs
 - b. NEMA 1 flushmount (catalog number ends with L): 10.50L x 7.50W x 3.50D inches, 6.8 lbs; flushmount plate dimensions are 14.00L x 11.00W inches
 - c. NEMA 1 with disconnect (catalog number ends with M): 10.70L x 11.10W x 5.80D inches, 14.7 lbs
 - d. NEMA 4 and 4X (catalog number ends with N or P): 11.30L x 8.70W x 5.40D inches, 14.6 lbs

- e. NEMA 4 and 4X with disconnect (catalog number ends with O or Q): 12.30L x 12.50W x 7.70D inches, 27.5 lbs

Table 5. Specifications

Description	Specification
Surge capacity ratings available	50, 80, 100, 120, 160, 200, 250, 300, 400 kA per phase
Nominal discharge current (I _n)	20 kA
Short circuit current rating (SCCR)	200 kA
SPD type	Basic feature package = Type 1 (can also be used in Type 2 applications) Standard and Standard with Surge Counter feature packages = Type 2
Single split phase voltages available	120/240
Three-phase wye system voltages available	120/208, 127/220, 230/400, 277/480, 347/600
Three-phase delta system voltages available	240, 480, 600
Input power frequency	50/60 Hz
Power consumption (basic units)—voltage codes	
208Y, 220Y, 240S, 240D, and 240H	0.5W
400Y, 480Y, and 480D	1.1W
600Y and 600D	1.3W
Power consumption—voltage codes ①	
208Y, 220Y, 240S, 240D, and 240H	0.6W
400Y, 480Y, and 480D basic	1.7W
600Y and 600D	2.1W
Protection modes	Single split phase L-N, L-G, N-G, L-L Three-phase wye L-N, L-G, N-G, L-L Three-phase delta L-G, L-L Three-phase high-leg delta L-N, L-G, N-G, L-L
Maximum continuous operating voltage (MCOV)	
240S, 208Y, 220Y, and 240H	150 L-N, 150 L-G, 150 N-G, 300 L-L
400Y and 480Y	320 L-N, 320 L-G, 320 N-G, 640 L-L
600Y	420 L-N, 420 L-G, 420 N-G, 840 L-L
240D	320 L-G, 320 L-L
480D	640 L-G, 640 L-L
600D	840 L-G, 840 L-L
Ports	1
Operating temperature	-40°C–50°C (-40°F–122°F)
Operating humidity	5%–95%, noncondensing
Operating altitude	Up to 16,000 ft (5000m)
Seismic withstand capability	Meets or exceeds the requirements specified in IBC® 2006, CBC 2007, and UBC® Zone 4
Form C relay contact ratings	150 Vdc or 125 Vac, 1A maximum
Form C relay contact logic	Power ON, normal state—NO contact = open, NC contact = closed Power OFF or fault state—NO contact = closed, NC contact = open
EMI/RFI filtering attenuation ①	Up to 50 dB from 10 kHz–100 MHz
Agency certifications and approvals	UL 1449 3rd Edition listed, CSA®, UL 1283 (Type 2 SPDs only)
Warranty	10 years

① Standard and standard with surge counter units.

Eaton Corporation
Electrical Sector
1111 Superior Ave.
Cleveland, OH 44114
United States
877-ETN-CARE (877-386-2273)
Eaton.com

© 2010 Eaton Corporation
All Rights Reserved
Printed in USA
Publication No. TD01005018E / Z9922
May 2010



PowerChain Management is a registered trademark of Eaton Corporation.

All other trademarks are property of their respective owners.