



SONOS
THE WIRELESS HI-FI SYSTEM

Sonos[®] PLAYBAR
Product Guide

THIS DOCUMENT CONTAINS INFORMATION THAT IS SUBJECT TO CHANGE WITHOUT NOTICE.

No part of this publication may be reproduced or transmitted in any form or by any means, electronic or mechanical, including but not limited to photocopying, recording, information retrieval systems, or computer network without the written permission of Sonos, Inc.

Sonos and all other Sonos product names and slogans are trademarks or registered trademarks of Sonos, Inc. Sonos Reg. U.S. Pat. & Tm. Off.

Sonos products may be protected by one or more patents. Our patent-to-product information can be found here:

sonos.com/legal/patents

iPhone®, iPod®, iPad® and iTunes® are trademarks of Apple Inc., registered in the U.S. and other countries.

Windows® is a registered trademark of Microsoft Corporation in the United States and other countries.

Android® is a trademark of Google, Inc.

Manufactured under license from Dolby Laboratories. Dolby and the double-D symbol are trademarks of Dolby Laboratories.

Amazon, Kindle, Kindle Fire, the Amazon Kindle logo and the Kindle Fire logo are trademarks of Amazon.com, Inc. or its affiliates.

MPEG Layer-3 audio decoding technology licensed from Fraunhofer IIS and Thomson.

Sonos uses MSNTP software, which was developed by N.M. Maclaren at the University of Cambridge.

© Copyright, N.M. Maclaren, 1996, 1997, 2000; © Copyright, University of Cambridge, 1996, 1997, 2000.

All other products and services mentioned may be trademarks or service marks of their respective owners.

November 2014

©2004-2014 by Sonos, Inc. All rights reserved.

Sonos PLAYBAR[®]

Flood any room with epic, full-theater HiFi sound and wirelessly stream all the music on earth through one easy-to-use player.

- Sophisticated 9-speaker design
- Connects to your TV using a single optical cable and plays everything that's connected to the TV, including cable boxes and game consoles
- Can be placed flat on a TV stand or mounted horizontally above or below the TV
- Compatible with Dolby[®] Digital and stereo

It takes just a few minutes to get your PLAYBAR up and running—turn to page 1 to get started. Once you've got it set up, you can add additional Sonos products any time.

Note: One Sonos product must be connected to your broadband router. If the PLAYBAR will not be located near your router, you can connect a Sonos BRIDGE™ or any Sonos player (purchased separately) to the router instead.

What's in the Box

- Sonos PLAYBAR
- Power Cord
- 5 ft. /1.5m TOSLINK Optical Audio Cable
- Ethernet Cable
- Quick Start Guide
- Important Product Information Booklet

What's Required

Television requirements

The PLAYBAR is compatible with any television that has an optical digital audio output.

Home network requirements

Note: Your network must have a high-speed Internet connection, as the Sonos system is designed to provide you with free, online software updates. Your Sonos system must be registered to receive these updates so **be sure to register** during the setup process. We do not share your e-mail address with other companies.

- High-speed DSL/Cable modem, or fiber-to-the-home broadband connection for proper playback of Internet-based music services. (If your Internet service provider only offers Satellite Internet access, you may experience playback issues due to fluctuating download rates.)

- If your modem is not a modem/router combination and you want to take advantage of Sonos' automatic online updates, or stream music from an Internet-based music service, **you must install a router in your home network**. If you do not have a router, purchase and install one before proceeding. If you are going to use the Sonos Controller App on an Android™ or iOS device, or you are setting up Sonos wirelessly, you will need a *wireless* router. Please visit our Web site at <http://faq.sonos.com/apps> for more information.

Note: Sonos communicates over a 2.4GHz home network supporting 802.11 b/g wireless technology. 5GHz networks are not supported in a completely wireless Sonos setup.

- Connect a Sonos BRIDGE, BOOST or player to your router if:
 - You have a larger home where the WiFi performance isn't reliable and you want to strengthen the wireless performance of your Sonos system.
 - Your WiFi network is already in high demand with streaming video and web surfing and you want to create a separate wireless network exclusively for your Sonos speakers.
 - You want to pair a SUB™ and/or a pair of PLAY:1® or PLAY:3™ speakers with your PLAYBAR to create a 3.1 or 5.1 home theater setup.
 - Your home network is 5GHz only (not switchable to 2.4GHz).
- For best results, you should connect the computer or NAS drive that contains your personal music library collection to your home network router using an Ethernet cable.

Before You Begin

Prior to installing the Sonos PLAYBAR, make sure all external components, such as your cable box, DVD player, etc. are connected directly to your TV.

If you have any existing home theater or surround sound equipment, disconnect it from your television.

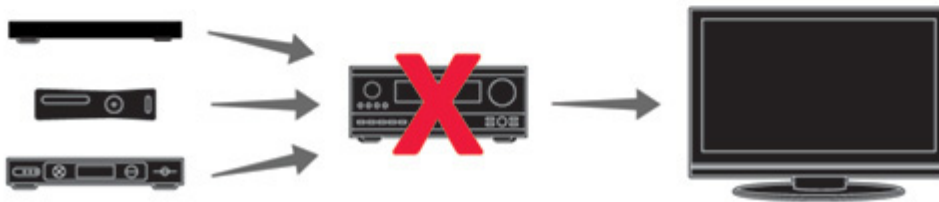
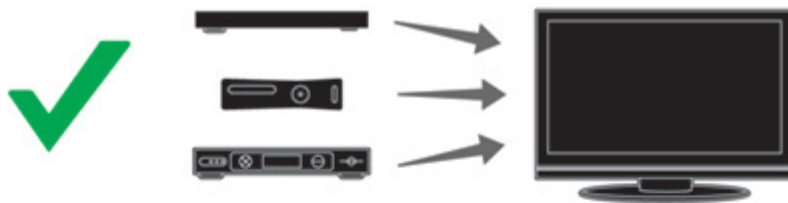

PLAYBAR Front

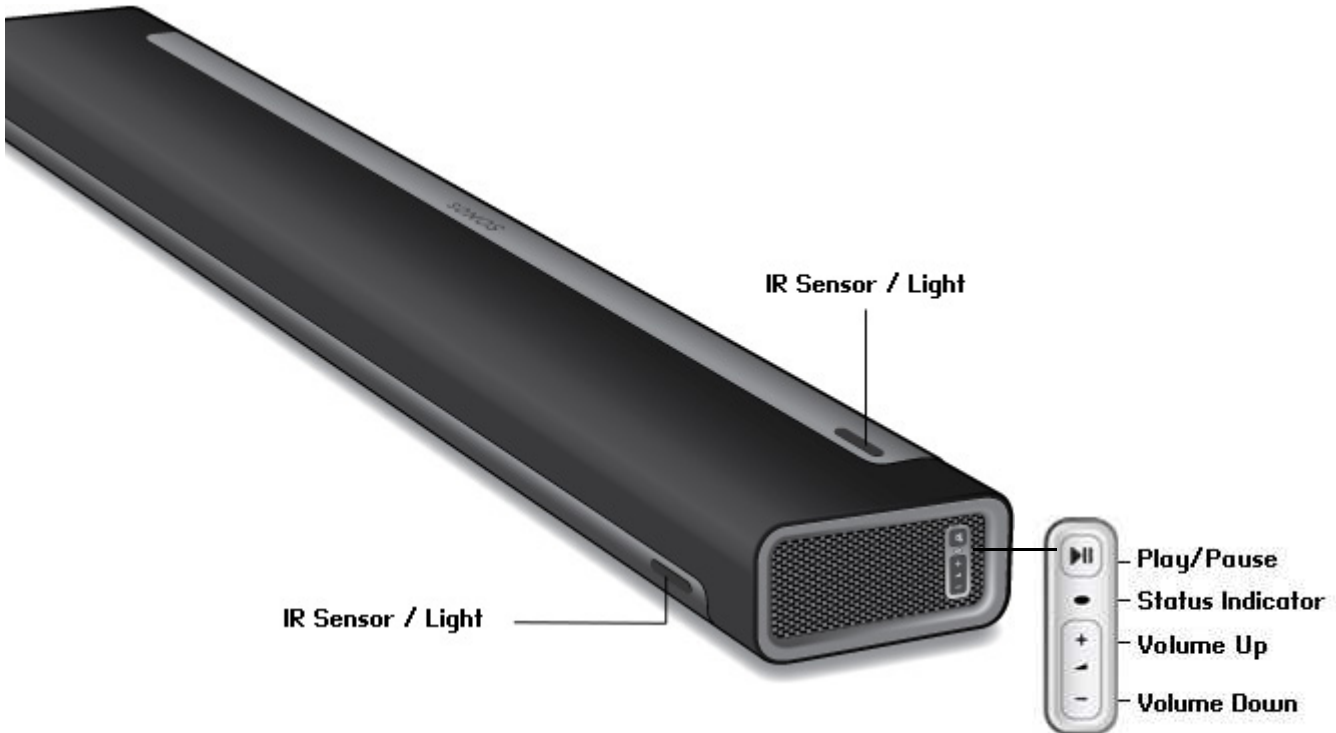

Note: The grill cloth is not removable. Tampering with the cloth may damage your PLAYBAR.

Play/Pause

Toggles between playing and pausing the audio.

- When the TV is on, press *once* to mute the audio
- When the TV is off, press *once* to restart the music source that was in use prior to the TV audio; press *twice* to skip to the next track (if applicable to the selected music source)

Status Indicator Light

Indicates the status of the PLAYBAR.

When the PLAYBAR is in normal operation, the LED is white. If desired, you can adjust this setting so the white light does not display. See "White status light" on page 15 for more information.

For a complete list of status indications, go to <http://faq.sonos.com/led>.

Volume Up (+)

Volume Down (-)

Press these buttons to adjust the volume up and down.

IR (InfraRed) Sensors / Signal Lights

The IR sensor receives the signals sent by a remote control.

When the PLAYBAR receives a volume or mute command, the IR signal light displays momentarily. If desired, you can adjust this setting so the light never displays. See "IR signal light" on page 14 for more information.

PLAYBAR Back

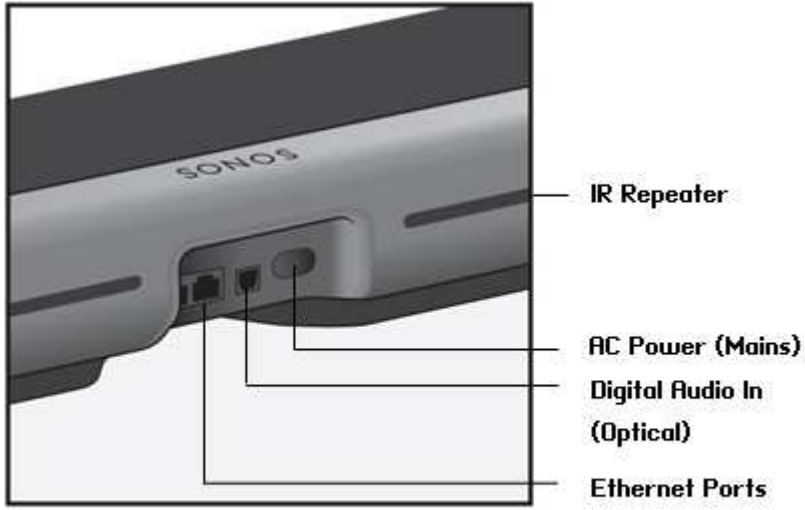

Ethernet Ports (2)

You can use an Ethernet cable to connect the PLAYBAR to your home network.

Digital Audio In (Optical)

Use an audio optical cable (supplied) to connect the Sonos PLAYBAR'S digital audio input to the optical digital output on your television. Take care not to bend or twist the cable.



The PLAYBAR's digital audio in and the optical cable end are 'D-shaped'—be sure to align for proper insertion.

AC Power (Mains) Input

Use only the supplied power cord to connect to a power outlet (using a third party power cord will void your warranty). Be sure to use the proper power adapter for your country. *Push the power cord firmly into the PLAYBAR until it is flush with the surface.*

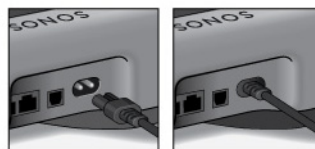

IR Repeater

Allows the commands from your remote control to reach your TV if the PLAYBAR is positioned in front of the TV. This setting is on by default, but can be turned off. See "IR repeater" on page 14 for more information.

Selecting a Location

The PLAYBAR's flexible design allows for multiple orientations. You can wall mount it above or below your television or place it on a tabletop. See the guidelines below for more information.

Tabletop

- Lay the PLAYBAR horizontally and flat on its feet.
- Do not place vertically or upright on its side.
- To preserve audio quality, ensure the connector panel faces **toward** the TV—Sonos logo should be closer to your TV.
- There is no placement restriction between the TV and PLAYBAR as long as the television's IR is not blocked. The PLAYBAR IR repeater is designed for at least 2" (50mm) distance, but may work at a closer distance.
- Do not place the PLAYBAR in a cabinet or on a walled shelf. Both ends of the PLAYBAR should be at least 1 ft. (30cm) from a wall or other obstruction.

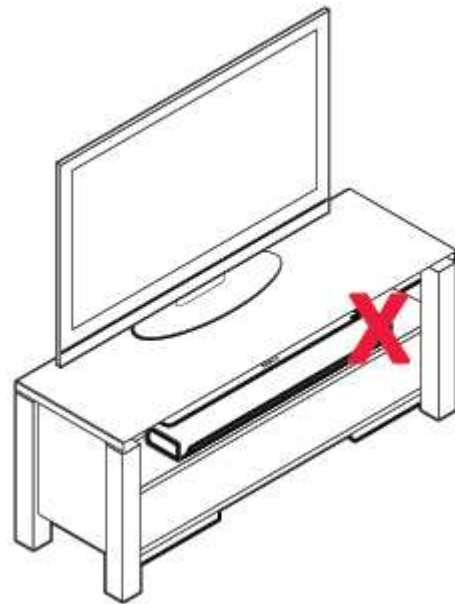
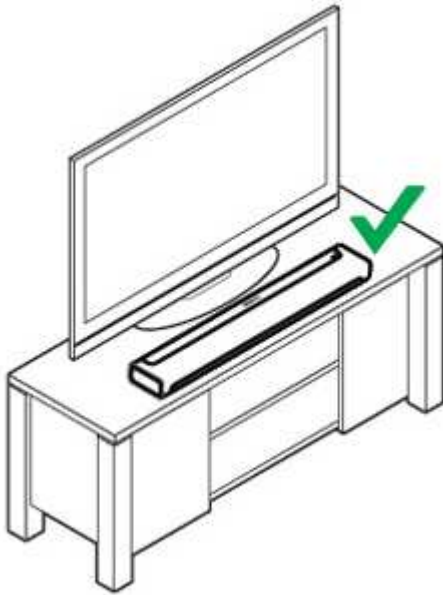

Wall mounting

The PLAYBAR can be mounted above or below your television using the PLAYBAR Wall Mount Kit (purchased separately). Please turn to page 22 for detailed wall-mounting instructions.

Setting Up the PLAYBAR

The PLAYBAR is compatible with Sonos software versions **4.0 and later**. If you are adding the PLAYBAR to an existing Sonos system, be sure to check for software updates before adding the PLAYBAR to your Sonos system.

1. Carefully unpack the package contents.
2. Choose a location for the PLAYBAR. Refer to "Selecting a Location" on page 6 for help with this step.
3. Remove the protective cap from each end of the optical audio cable.
4. Connect the optical audio cable (supplied) from your TV's digital audio **out** (optical) to the PLAYBAR's digital audio **in** (optical) being careful not to twist or bend the cable. **The PLAYBAR's digital audio in and the optical cable are 'D-shaped'—be sure to align for proper insertion.**

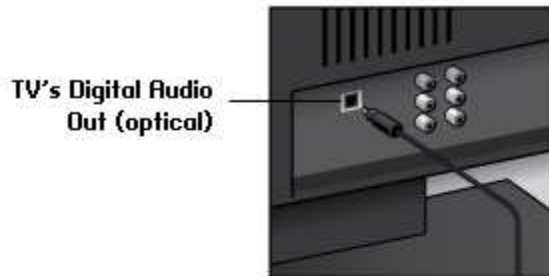

IMPORTANT: Be sure to remove the protective caps from each end of the supplied optical audio cable before inserting.

5. Attach the power adapter to the PLAYBAR and apply power. *Be sure to push the power cord firmly into the PLAYBAR until it is flush with the surface.*

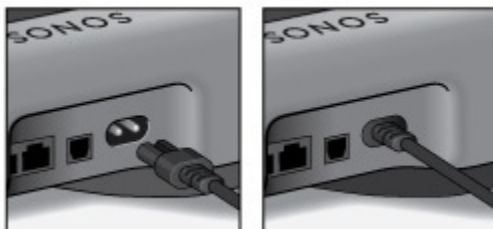

The status indicator light on the right side of the unit will begin to flash.



- 6. (OPTIONAL) If you are setting up your PLAYBAR with a SUB and/or surround speakers, position them in your room, apply power and connect a Sonos BRIDGE, BOOST or player to your router. (You will be prompted to add these components to your Sonos system after the PLAYBAR is added.)

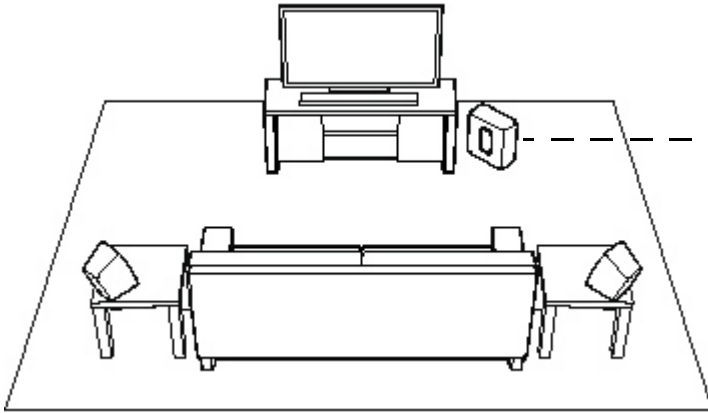

If you purchased a Sonos SUB, place the SUB wherever it best fits your room—standing up or lying flat. You can place it in a corner, against the wall, behind, under, or next to any piece of furniture on any kind of floor surface.

If you purchased Sonos PLAY:1 or PLAY:3 surround speakers, place the speakers to the left and right of your main viewing position, level with or behind the main viewing position. They can be placed either horizontally or vertically, but make sure both speakers have the same orientation.

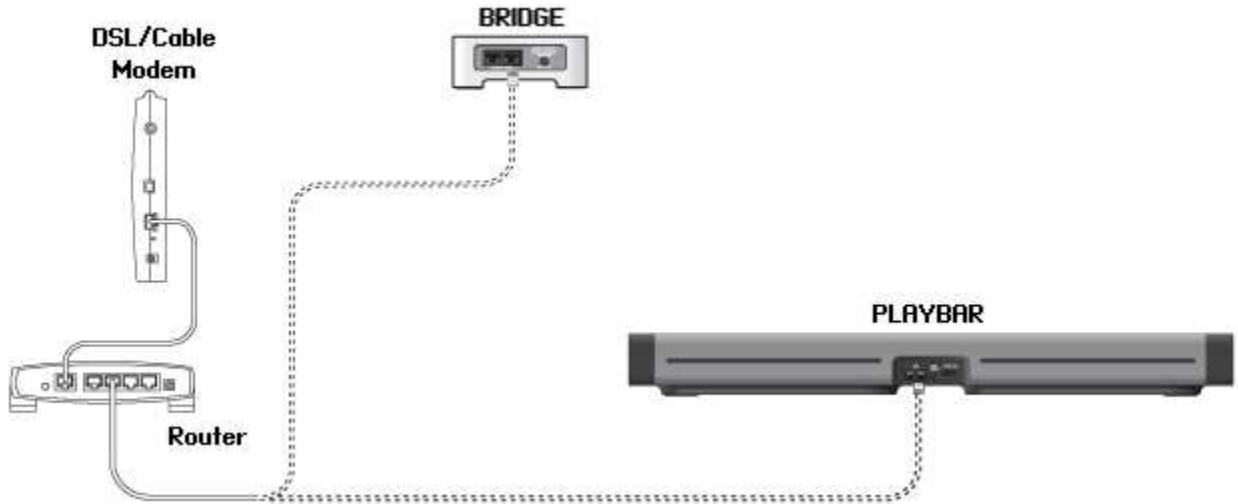

Note: Expandable PLAYBAR home theater setup
 For a 3.1 home theater experience, pair a SUB with your PLAYBAR.
 For a 5.1 home theater experience, pair a SUB and a pair of PLAY:1 or PLAY:3 speakers with your PLAYBAR.
 If you are expanding your PLAYBAR home theater setup, be sure you have a BRIDGE, BOOST or Sonos player wired directly to your router.

7. Using a handheld Sonos controller (including Sonos CONTROL, iPad®, iPhone®, iPod touch®, Android® smartphone or tablet, Kindle Fire™), open the app and follow the online prompts to set up your Sonos system.

If you don't have a Sonos controller app installed, download it from the application store on your device.

Note: Sonos does not recommend using the Sonos Controller for Mac or PC to set up your PLAYBAR.

If you are setting up a new Sonos system, when prompted, add your Sonos products in the following order:

- a. Add the Sonos product that's connected to your router.
- b. Add the PLAYBAR (if it is not the product connected to your router.)
- c. Add any additional Sonos products you purchased.

If you are adding to an existing Sonos system:

- a. First check for software updates—the PLAYBAR is compatible with Sonos software versions **4.0 and later**.
- b. Add the PLAYBAR to your Sonos system by selecting **Add a Player or SUB** from the **Settings** menu on a handheld controller.
- c. Add any additional Sonos products you purchased.

You may be prompted to update the new Sonos product(s) after you add them to your Sonos system.

Thick walls, 2.4 GHz cordless telephones, or the presence of other wireless devices can interfere with or block the wireless network signals from your Sonos system. If you experience difficulty after positioning a Sonos product, try one or more of the following resolutions—relocate the Sonos product; change the wireless channel your music system is operating on; connect a Sonos product to your router if your setup is currently wireless.

If you'd like additional assistance:

- *If you need help turning off your TV speakers, see page 27 for more information.*
- *If you need help configuring a remote control to work with your PLAYBAR, see page 10 for more information.*
- *If a message appears on the TV whenever you adjust the volume up and down, it may be possible to eliminate it. If you are using a cable remote, see page 26. If you are using a universal remote, see page 27 for additional help.*
- *If you want to play music through the PLAYBAR, see page 20 for more information.*

PLAYBAR Settings

Follow the steps below if you wish to make changes to any PLAYBAR settings or the way the PLAYBAR works with your television.

- Remote Control Setup
- Equalization
- Recalibrating the Audio
- TV Dialog Settings
- Speech Enhancement
- Night Sound

- TV Autoplay
- IR Signal Light
- IR Repeater
- White Indicator Light
- Room Name
- Add SUB / Remove SUB (if SUB is present)
- Add / Remove Surround Speakers (if surround speakers are present)

Remote control setup

During PLAYBAR setup, you were guided through the process of configuring a remote control. If you did not configure one then, or wish to use a different remote control with your PLAYBAR, follow the steps below.

If you are configuring a new remote because a distracting message appears on the television whenever you adjust the volume, please go to "Eliminating annoying messages on your TV when using a cable, satellite, or set top box remote" on page 26, or "Eliminating annoying messages on your TV when using a universal remote" on page 27.

Using a handheld Sonos controller

1. Select **Room Settings** from the **Settings** menu.
2. Select the room your PLAYBAR is located in.
3. Select **TV Setup and Control** -> **Remote Control Setup**.

If a remote control is already configured for use with your PLAYBAR you will be asked if you want to replace it.

4. Pick up the remote control you wish to begin using with the PLAYBAR.
5. Point the remote at the PLAYBAR and press the **Volume Up** button on the remote control.
 - If the remote control is recognized, click **Done**. You can now use that remote to control the volume and mute settings on your PLAYBAR.
 - If the remote control is not recognized, you will be prompted to make additional button presses to complete the setup process.

Using the Sonos Controller for Mac or PC

1. Select **Manage** -> **Settings** (PC) or **Sonos** -> **Preferences** (Mac).
2. Select **Room Settings** if it is not already highlighted on the left.
3. Choose the room the PLAYBAR is located in from the **Room Settings for** drop-down.
4. Select the **TV Setup** tab.
5. Click **Remote Control Setup**.
6. Pick up the remote control you wish to begin using with the PLAYBAR, and then click **Next**.
7. Point the remote at the PLAYBAR and press the **Volume Up** button on the remote control.
 - If the remote control is recognized, click **Done**. You can now use that remote to control the volume and mute settings on your PLAYBAR.
 - If the remote control is not recognized, you will be prompted to make additional button presses to complete the setup process.

If a message appears on the television whenever you adjust the volume up and down, please see "Eliminating annoying messages on your TV when using a cable, satellite, or set top box remote" on page 26 or "Eliminating annoying messages on your TV when using a universal remote" on page 27.

Equalization (EQ)

During the PLAYBAR setup process you were guided through the audio calibration process. If desired, you can change the sound settings (bass, treble or loudness) for the Sonos PLAYBAR. *Bass* boosts lower frequencies, *treble* boosts higher frequencies, while *loudness* boosts certain frequencies, including bass, to improve the sound at low volume.

Any manual EQ changes you make will be reset whenever you go through the audio recalibration process (see page 11 for more information).

Using a handheld Sonos controller

1. From the **Settings** menu, select **Room Settings**.
2. Select the room you want to adjust.
3. Select **Equalization**.
4. Choose one of the following options:
 - Drag your finger across the bass or treble sliders to make adjustments.
 - Select **On** or **Off** to adjust the **Loudness** setting.

Using the Sonos Controller for Mac or PC

1. Select **Manage** -> **Settings** (PC) or **Sonos** -> **Preferences** (Mac).
2. Select **Room Settings** if it is not already highlighted on the left.
3. Choose the room the PLAYBAR is located in from the **Room Settings for** list, and then select the **EQ** tab.
4. Choose one of the following options:
 - Click and drag the bass or treble sliders to make adjustments.
 - Click the **Loudness** checkbox to turn the loudness setting on or off.
5. Close the **Settings** window when changes are complete.



Recalibrating the audio

If you have a SUB and/or Sonos surround speakers associated with your PLAYBAR, you may wish to make some adjustments after initial setup. You will likely wish to recalibrate the audio if you move any Sonos products in the room.



If you made any manual adjustments to EQ settings, these will be reset during the recalibration process.

Using a handheld Sonos controller

1. From the **Settings** menu, select **Room Settings**.
2. Select the room that is associated with the surround components. It appears as *Room (+SUB)* or *Room (+LS+RS)* or *Room (+SUB+LS+RS)* on the **Room Settings** menu.
3. Select **Advanced Audio** -> **Recalibrate Audio**.
4. Follow the prompts to optimize your audio performance.

- If you have a SUB associated with your PLAYBAR, you will be asked to choose between 2 test sounds:
 - Press Play  to compare the volume of two test sounds, A and B, and then select **No Difference, A is louder** or **B is louder**. If you don't hear a noticeable difference, select **No Difference**.
 - Press Play  to listen to a test sound, and then select the level you prefer.
- If you have surround speakers associated with your PLAYBAR, you will be asked to answer some room configuration questions.

Using the Sonos Controller for Mac or PC

1. Select **Manage** -> **Settings** (PC) or **Sonos** -> **Preferences** (Mac).
2. Select **Room Settings**.
3. Select the room that is associated with the surround components. It appears as *Room* (+SUB) or *Room* (+LS+RS) or *Room* (+SUB+LS+RS) on the **Room Settings** menu.
4. Select the **Basic** tab, and then select **Recalibrate Audio**.
5. Follow the prompts to optimize your audio performance:
 - If you have a SUB associated with your PLAYBAR, you will be asked to choose between 2 test sounds:
 - Press Play  to compare the volume of two test sounds, A and B, and then select **No Difference, A is louder** or **B is louder**. If you don't hear a noticeable difference, select **No Difference**.
 - Press Play  to listen to a test sound, and then select the level you prefer.
 - If you have surround speakers associated with your PLAYBAR, you will be asked to answer some room configuration questions.

TV dialog settings

Using a handheld Sonos controller

1. From the **Settings** menu, select **Room Settings**.
2. Select the room the PLAYBAR is located in.
3. Select **Advanced Audio** -> **TV Dialog Settings**.
4. **Audio Delay (Lip Sync)**. Drag your finger across the slider to increase or decrease the sound delay if the image and the sound are not in sync.

Using the Sonos Controller for Mac or PC

1. Select **Manage** -> **Settings** (PC) or **Sonos** -> **Preferences** (Mac).
2. Select **Room Settings** if it is not already highlighted on the left.
3. Choose the room the PLAYBAR is located in from the **Room Settings for** drop-down.
4. Select the **TV Dialog** tab.
5. Click and drag the **Audio Delay (Lip Sync)** slider to increase or decrease the sound delay if the image and the audio are not in sync.
6. Close the **Settings** window when changes are complete.

Additional TV sound options



Speech Enhancement

The **Speech Enhancement** setting makes the TV dialog easier to hear. Touch the icon on your Sonos controller's **Now Playing** screen to turn this setting on or off. (If the setting isn't visible, make sure the room with the PLAYBAR is selected.)



Night Sound

The **Night Sound** setting adjusts the audio for night time viewing so you can reduce the volume and still experience proper balance and range. At lower volumes, quiet sounds are enhanced and the intensity of loud sounds is reduced. Touch the icon on your Sonos controller's **Now Playing** screen to turn this setting on or off. (If the setting isn't visible, make sure the room with the PLAYBAR is selected.)

TV autoplay

When TV Autoplay is set to *On*, TV audio automatically plays through the PLAYBAR when you turn on your television—if music is playing when the TV is turned on, the music immediately stops and the PLAYBAR switches to TV audio. Additionally, if the PLAYBAR is in a room group when the TV is turned on, it automatically drops from the group. This setting is *On* by default.

Using a handheld Sonos controller

1. From the **Settings** menu, select **Room Settings**.
2. Select the room the PLAYBAR is located in.
3. Select **TV Setup and Control** -> **TV Autoplay**.
4. Select **On** or **Off**.

Using the Sonos Controller for Mac or PC

1. Select **Manage** -> **Settings** (PC) or **Sonos** -> **Preferences** (Mac).
2. Select **Room Settings** if it is not already highlighted on the left.
3. Choose the room the PLAYBAR is located in from the **Room Settings for** drop-down.
4. Select the **TV Setup** tab.
5. Check the **TV Autoplay** checkbox to turn this setting on, uncheck to turn it off.
6. Close the **Settings** window when changes are complete.

Ungroup on autoplay

As with any Sonos player, you can group and ungroup the PLAYBAR with other rooms. If *ungroup on autoplay* is checked, any Sonos rooms that are grouped with the PLAYBAR when the TV is turned on will automatically drop from the group. This setting is *Yes* by default.

Using a handheld Sonos controller

1. From the **Settings** menu, select **Room Settings**.
2. Select the room the PLAYBAR is located in.
3. Select **TV Setup and Control** -> **Ungroup on Autoplay**.

4. Select **Yes** or **No**.

Using the Sonos Controller for Mac or PC

1. Select **Manage** -> **Settings** (PC) or **Sonos** -> **Preferences** (Mac).
2. Select **Room Settings** if it is not already highlighted on the left.
3. Choose the room the PLAYBAR is located in from the **Room Settings for** drop-down.
4. Select the **TV Setup** tab.
5. Check the **Ungroup on Autoplay** checkbox to turn this setting on, uncheck to turn it off.
6. Close the **Settings** window when changes are complete.

IR signal light

A light displays on the PLAYBAR when an IR signal is being sent. If desired, you can adjust this setting so the IR light never displays. This setting is *On* by default.

Using a handheld Sonos controller

1. From the **Settings** menu, select **Room Settings**.
2. Select the room the PLAYBAR is located in.
3. Select **TV Setup and Control** -> **IR Signal Light**.
4. Select **On** or **Off**.

Using the Sonos Controller for Mac or PC

1. Select **Manage** -> **Settings** (PC) or **Sonos** -> **Preferences** (Mac).
2. Select **Room Settings** if it is not already highlighted on the left.
3. Choose the room the PLAYBAR is located in from the **Room Settings for** drop-down.
4. Select the **TV Setup** tab.
5. Check the **IR Signal Light** checkbox to turn this setting on, uncheck to turn it off.
6. Close the **Settings** window when changes are complete.

IR repeater

When the PLAYBAR is placed in front of your TV on a tabletop, it may block the IR sensor on your TV. The IR repeater setting allows the PLAYBAR to repeat the signal to your TV. This setting is *On* by default.

Using a handheld Sonos controller

1. From the **Settings** menu, select **Room Settings**.
2. Select the room the PLAYBAR is located in.
3. Select **TV Setup and Control** -> **IR Repeater**.
4. Select **On** or **Off**.

Using the Sonos Controller for Mac or PC

1. Select **Manage** -> **Settings** (PC) or **Sonos** -> **Preferences** (Mac).
2. Select **Room Settings** if it is not already highlighted on the left.
3. Choose the room the PLAYBAR is located in from the **Room Settings for** drop-down.
4. Select the **TV Setup** tab.
5. Check the **IR Repeater** checkbox to turn this setting on, uncheck to turn it off.
6. Close the **Settings** window when changes are complete.

White status light

A white light displays on the side of the PLAYBAR to indicate that the unit is functioning in normal operation. If desired, you can turn this indicator light off so that when the PLAYBAR is in normal operation the white light does not display. This setting is *On* by default.

If the Status indicator light begins to flash orange, go to <http://faq.sonos.com/led> for additional information.



Using a handheld Sonos controller

1. From the **Settings** menu, select **Room Settings**.
2. Select the room you want to change.
3. Select **White Status Light**.
4. Select **On** or **Off**.

Using the Sonos Controller for Mac or PC

1. Select **Manage** -> **Settings** (PC) or **Sonos** -> **Preferences** (Mac).
2. Select **Room Settings** if it is not already highlighted on the left.
3. Choose the room you want to change from the **Room Settings for** drop-down.
4. From the **Basic** tab, click the **White Status Light On** checkbox to turn the light on or uncheck to turn it off.

Changing room names

Using a handheld Sonos controller

1. From the **Settings** menu, select **Room Settings**.
2. Select the room you wish to change.
3. Select **Room Name**.

4. Select a new name from the list and touch **OK**, or select **Enter New** to type a unique name.

Using the Sonos Controller for Mac or PC

1. Select **Manage** -> **Settings** (PC) or **Sonos** -> **Preferences** (Mac).
2. Select **Room Settings** if it is not already highlighted on the left.
3. Choose the room you wish to change from the **Room Settings for** drop-down list.
4. Choose a new name from the **Room Name** list.

Sonos SUB

Adding a Sonos SUB

You can pair a SUB with the PLAYBAR to add to your cinematic experience.

Using a handheld Sonos controller

1. From the **Settings** menu, select **Room Settings**.
2. Select the room the PLAYBAR is located in.
3. Select **Add SUB**.
4. Follow the prompts to add the SUB to your Sonos system.

Using the Sonos Controller for Mac or PC

1. Select **Manage** -> **Settings** (PC) or **Sonos** -> **Preferences** (Mac).
2. Select **Room Settings** if it is not already highlighted on the left.
3. From the **Basic** tab, select **Add SUB**.
4. Follow the prompts to add the SUB to your Sonos system.

SUB settings

Follow the steps below if you wish to make any changes to the SUB settings.

Using a handheld Sonos controller

1. From the **Settings** menu, select **Room Settings**.
2. Select the room the PLAYBAR and SUB are located in. It appears as *Room (+SUB)* on the **Room Settings** menu.
3. Select **Advanced Audio** -> **SUB Settings**.
4. Choose one of the following:
 - **SUB**: Choose **On** or **Off** to turn the sound from the SUB on and off.
 - **SUB Level Adjustment**: Drag your finger across the slider to increase or decrease the volume of the SUB. (You can use this setting to match the subwoofer level to the level of your main speakers.)
 - **Placement Adjustment** (phase): Select **On** or **Off**.

Using the Sonos Controller for Mac or PC

1. Select **Manage** -> **Settings** (PC) or **Sonos** -> **Preferences** (Mac).
2. Select **Room Settings** if it is not already highlighted on the left.
3. Choose the room the PLAYBAR and SUB are located in from the **Room Settings for** drop-down. It appears as *Room (+SUB)*.
4. Select the **SUB** tab.
5. Choose one of the following:
 - **SUB**: Check to turn the sound from the SUB on; uncheck to turn it off.
 - **SUB Level Adjustment**: Click and drag the slider to increase or decrease the volume of the SUB. (You can use this setting to match the subwoofer level to the level of your main speakers.)
 - **Placement Adjustment** (phase): Check to turn on; uncheck to turn it off.

Removing a SUB

Using a handheld Sonos controller

1. From the **Settings** menu, select **Room Settings**.
2. Select the room the SUB is associated with. It appears as *Room (+SUB)* on the **Room Settings** menu.
3. Select **Remove SUB**.
4. Choose one of the following settings:
 - If you want to associate the SUB with a different Sonos player, select **Choose Room for SUB** and then select another room.
 - If you are not going to use the SUB right now, select **Don't use SUB**. It will appear on the **Rooms** menu as *SUB (unused)* until you select it and associate it with another Sonos player.

Using the Sonos Controller for Mac or PC

1. Select **Manage** -> **Settings** (PC) or **Sonos** -> **Preferences** (Mac).
2. Select **Room Settings** if it is not already highlighted on the left.
3. Choose the room the PLAYBAR is located in from the **Room Settings for** drop-down list.
4. From the **Basic** tab, click **Remove SUB**.

Surround Speakers

Adding surround speakers

You can easily pair two PLAY:1 or PLAY:3 products with a PLAYBAR to function as left and right surround channels in your Sonos surround sound experience. You can either configure surround speakers during the setup process or follow the steps below to add them later.

- Make sure the Sonos players are the same—you cannot combine a PLAY:1 and a PLAY:3 to function as surround speakers.
- Pairing surround speakers with your PLAYBAR requires a wired connection so make sure you have a BRIDGE, BOOST or Sonos player connected to your router with an Ethernet cable before proceeding.
- Be sure to follow the instructions below to set up your surround speakers. Do not create a room group or stereo pair as these will not achieve the left and right surround channel functionality.

Using a handheld Sonos controller

1. From the **Settings** menu, select **Room Settings**.
2. Select the room the PLAYBAR is located in.
3. Select **Add Surround Speakers**.
4. Follow the prompts to add first a left and then a right surround speaker.

Using the Sonos Controller for Mac or PC

1. Select **Manage** -> **Settings** (PC) or **Sonos** -> **Preferences** (Mac).
2. Select **Room Settings** if it is not already highlighted on the left.
3. From the **Basic** tab, select **Add Surround Speakers**.
4. Follow the prompts to add first a left and then a right surround speaker.

Surround settings

The default setting is determined by the calibration process. If you wish to make a change, you can follow the steps below.

Using a handheld Sonos controller

1. From the **Settings** menu, select **Room Settings**.
2. Select the room the PLAYBAR and surround speakers are located in. It appears as *Room (+LS+RS)* on the **Room Settings** menu.
3. Select **Advanced Audio** -> **Surround Settings**.

4. Choose one of the following:
 - **Surrounds:** Choose **On** or **Off** to turn the sound from the surround speakers on and off.
 - **Surround Level Adjustment:** Drag your finger across the slider to increase or decrease the volume of the surround speakers.
 - **Music Playback:** Choose **Ambient** (default; subtle, ambient sound) or **Full** (enables louder, full range sound). This setting applies only to music playback, not TV audio.

Using the Sonos Controller for Mac or PC

1. Select **Manage** -> **Settings** (PC) or **Sonos** -> **Preferences** (Mac).
2. Select **Room Settings** if it is not already highlighted on the left.
3. Choose the room the PLAYBAR and surround speakers are located in from the **Room Settings for** drop-down.
4. Select the **Surrounds** tab.
5. Choose one of the following:
 - **Surrounds:** Check to turn the sound from the surround speakers on; uncheck to turn it off.
 - **Surround Level Adjustment:** Click and drag the slider to increase or decrease the volume of the surround speakers.
 - **Music Playback:** Choose **Ambient** (default; subtle, ambient sound) or **Full** (enables louder, full range sound). This setting applies only to music playback, not TV audio.
6. Close the **Settings** window when changes are complete.

Removing surround speakers

Using a handheld Sonos controller

1. From the **Settings** menu, select **Room Settings**.
2. Select the room the surround speakers are associated with. The room name appears as *Room (+LS+RS)* on the **Room Settings** menu.
3. Select **Remove Surround Speakers**.
4. Select **Next** to drop the surround sound speakers from your surround system. If these were newly purchased players, they will appear as **Unused** on the **Rooms** menu. If the players existed in your household previously, they revert back to their previous state.

You can now move them to another room for individual use. If you want to add them back as surround speakers, see "Adding surround speakers" on page 18 for help.

Using the Sonos Controller for Mac or PC

1. Select **Manage** -> **Settings** (PC) or **Sonos** -> **Preferences** (Mac).
2. Select **Room Settings** if it is not already highlighted on the left.
3. Choose the room the PLAYBAR is located in from the **Room Settings for** drop-down list. The room name appears as *Room (+LS+RS)*.
4. From the **Basic** tab, click **Remove Surround Speakers**. If these were newly purchased players, they will appear as **Unused** in the **Rooms** pane. If the players existed in your household previously, they revert back to their previous state.

Playing Music

The PLAYBAR doubles as an all-in-one Sonos player that allows you to stream all the music on earth. You can use any Sonos controller to select music—simply touch **SONOS** to select from the music menu on a handheld controller, or click to select from the **MUSIC** pane within the Sonos Controller for Mac or PC. Radio

Note: If TV Autoplay is set to *On*, the PLAYBAR automatically stops playing music and switches to TV audio whenever the TV is turned on. For more information, see "TV autoplay" on page 13.

Radio

Sonos includes a radio guide that provides immediate access to thousands of free Internet radio stations and broadcast programs. You can easily find radio stations from all over the world—music, news, and variety programming, including archived shows and podcasts.

To select a radio station, simply select **Radio** and choose a station.

Music services

A music service is an online music store or online service that sells audio on a per-song, per audiobook, or subscription basis. Sonos is compatible with several music services - you can visit our Web site at www.sonos.com/howitworks/music/partners for the latest list. (Some music services may not be available in your country. Please check the individual music service's Web site for more information.)

If you are currently subscribed to a music service that's compatible with Sonos, simply add your music service user name and password information to Sonos as needed and you'll have instant access to the music service from your Sonos system.

1. To add a music service, touch **Add Music Services** from the **Sonos** music menu on your handheld controller.
2. Select the Sonos-compatible music service you would like to add.
3. Select **Add Account**, and then follow the on-screen prompts. Your login and password will be verified with the music service. As soon as your credentials have been verified, the music service displays on the **Sonos** music menu.

Free music service trials are available in some countries. (Please check the individual music service's Web site for more information.) If there is a music service trial visible on the **Music Services** menu, simply touch it to select. Touch **Add Account** -> **I'm new to [music service]**, and then follow the prompts to activate the music trial. After the trial period is up, you will need to subscribe to the music service to keep the music playing.

Local music library

The Sonos system can play music from any computer or network-attached storage (NAS) device on your home network where you have shared music folders. During the setup process, you are guided through the process of accessing your local music library (such as your iTunes library). Over time, you may wish to add or remove folders from this list.

To make changes to your local music library, select the **Settings** menu from a handheld Sonos controller and then choose one of the following options:

- To add a new music folder, select **Manage Music Library**-> **Music Library Setup** -> **Add New Share**.
- To remove a music folders, select **Manage Music Library** -> **Music Library Setup**. Touch the share you wish to remove and then select **Remove**.

The Sonos system indexes your local music so you can view your music collection by categories (such as artists, albums, composers, genres, or tracks.) If you add new music, simply update your music index to add this music to your Sonos music library.

- To update your music library, select **Manage Music Library** -> **Update Music Index Now**. If you'd like your music library to update automatically each day, select **Schedule Music Index Updates** and then select an update time.

Wireless iTunes playback

You can select and play music and podcasts stored on any iPad, iPhone, or iPod touch that's on the same network as your Sonos products. Playback is perfectly synchronized, in any or every room of your home. Simply choose **This iPad**, **This iPhone**, or **This iPod touch** from the Sonos app on your iOS device to make audio selections and then you can use any Sonos controller to control playback.

Wireless playback requires Sonos Controller App for iPhone or iPad version 3.8.3 or higher and devices running iOS software version 6.0 or later.

Wireless playback from Android devices

You can select and play music stored on any Android device that's on the same network as your Sonos products. Playback is perfectly synchronized, in any or every room of your home. Simply choose **This Mobile Device** from the Sonos app on your Android smartphone or tablet to make audio selections and then you can use any Sonos controller to control playback.

Wireless music playback is compatible with Sonos software update 4.1.1 and higher, and any device running Android 2.1 and higher. (Wireless playback of podcasts is supported on Android 2.2 and higher.)

Google Play Music (Android devices)

You can play music to your Sonos system directly from the Google Play Music app on any Android device. This feature is available for both Standard and All Access Google Play Music customers.

To play music directly from the Google Play Music app to your Sonos system, you must have both the Google Play Music app and the Sonos Controller App installed on your mobile device. Sonos playback from Google Play Music is compatible with Sonos software update 4.3 and higher, and with any device running Android 2.3 and higher.

Simply open the Google Play Music app and connect to a Sonos room or room group to start the music. When you are finished, disconnect the Sonos room from the app.

Wall Mounting

PLAYBAR can be wall mounted above or below your wall-mounted television using the PLAYBAR Wall Mount Kit. To preserve audio quality, ensure the connector panel faces away from the TV when mounted—the Sonos logo should be farther from your TV.

Note: It is recommended that you connect the power and audio cables to the PLAYBAR before mounting on the wall.

What you will need

- PLAYBAR Wall Mount Kit (sold separately)
 - Masking tape
 - An awl or other pointed tool
 - A Phillips head screw driver
 - Power drill with Phillips head attachment
1. Hold the PLAYBAR wall mount template (included in the wall mount kit) in the desired position on your wall. The PLAYBAR can be mounted either above or below your television.

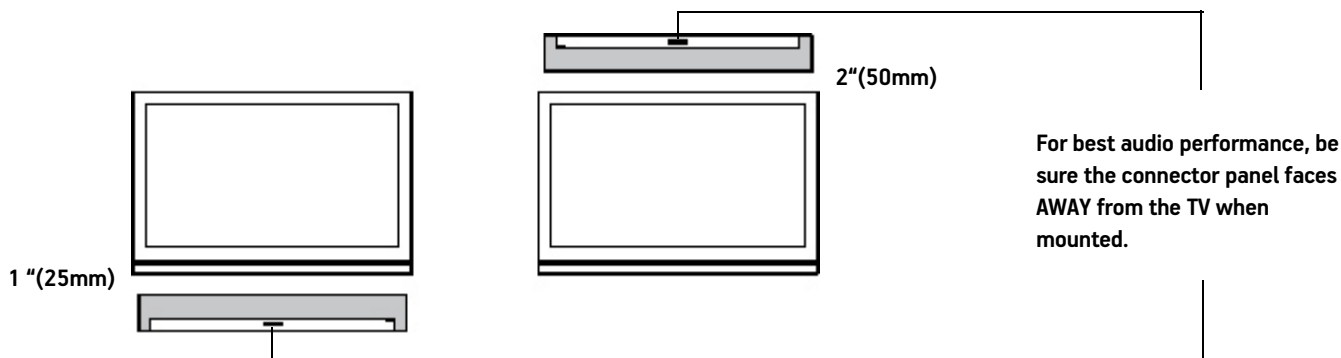

IMPORTANT: For optimal audio performance, Sonos recommends:

When mounting **below** a television, allow 1 inch (25mm) clearance between the PLAYBAR and the TV.

When mounting **above** a television, allow 2 inches (50mm) clearance between the PLAYBAR and the TV.

2. Use a level (included in wall mount kit) to ensure the template is horizontally level, and then tape the template securely to the wall.

- Use an awl or other sharp object to punch 4 small holes through 4 of the marked locations on the template. (If additional reinforcement is desired, 2 spare screws and anchors are included in the wall mount kit.) Placement may vary but holes should be located toward the corners, away from center.

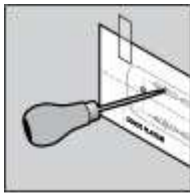

- Remove the template from the wall.
- Drill pilot holes.
Because the anchors and screws are designed to be self-starting, this step is optional. However pre-drilling will result in a more accurate installation. Refer to the table below for more information.

Wall Material	Pre Drill	Use Wall Anchors	Use Screws
Wood Stud	with 1/8" (3mm) bit	No	Yes
Drywall (no stud)	with 3/16" (4.5mm) bit	Yes	Yes
Hard wallboard or double board	with 3/16" (4.5mm) bit	Yes	Yes
Plaster	with 1/4" (6.5mm) bit	Yes	Yes
Concrete or Brick	with 1/8" (3mm) bit	Yes	Yes

6. Insert and secure the wall anchors (supplied in the wall mount kit).
 - If you are drilling into wood stud, do not use the wall anchors.
 - If you are drilling into Sheetrock, screw the wall anchors into the drywall with a Phillips head screwdriver until the head is flat against or slightly below the wall surface, being careful not to overtighten.

Note: The anchors can be installed using a screw gun or a regular power drill with a Phillips head screwdriver attachment. If you are drilling into sheetrock, the surface of the drywall may distort slightly or dimple as the anchor is installed. This is not unusual.

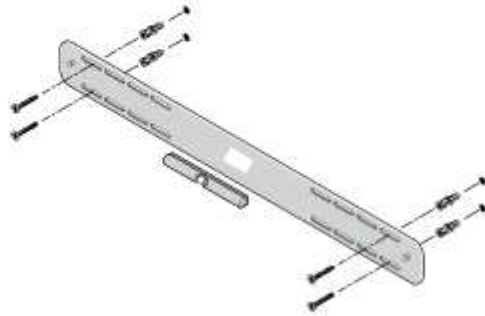

7. Fasten the PLAYBAR bracket to the wall using the screws supplied in the wall mount kit. Use the level to verify accuracy a final time, and then tighten the screws securely.

Note: If using wall anchors, continue to drill for a few seconds even after it appears the screw is secure— the anchor will likely spin a little as the anchor expands inside the wall.

8. Hang the PLAYBAR securely on the two (2) bracket pegs.

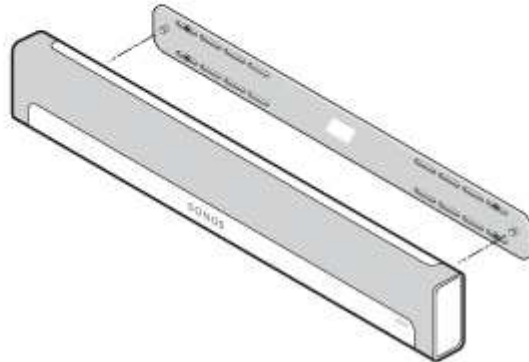
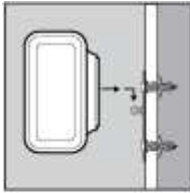

Basic Troubleshooting

Warning: Do not open the product as there is a risk of electric shock. Under no circumstances should the product be repaired by anyone other than an authorized Sonos repair center, as this will invalidate the warranty. Please contact Sonos Customer Support for more information.

The grill cloth is not removable. Tampering with the cloth may damage your PLAYBAR.

If a problem occurs, you can try the troubleshooting suggestions listed below. If one of these doesn't remedy the problem, or you are not sure how to proceed, please contact the Sonos Customer Support team and we'll be happy to help.

- **Customer Support**
 - Visit our PLAYBAR reference section at <http://moreinfo.sonos.com/PLAYBAR>
 - Visit our Web site at www.sonos.com/support
 - Email us at support@sonos.com

PLAYBAR not detected during setup

- Did you allow Sonos to check for updates? *The Sonos PLAYBAR requires software version 4.0 or later.*
- Is the power cord properly seated? *Be sure to push the power cord firmly into the PLAYBAR until it is flush with the surface.*
- If either of these is not the problem, a network issue may be preventing the PLAYBAR from connecting to your Sonos system. *Try moving the Sonos products closer together.*

Eliminating annoying messages on your TV *when using a cable, satellite, or set top box remote*

After you disable your TV speakers, your television might display an annoying or confusing message when you adjust the volume on the PLAYBAR. This could be a message reminding you that your TV speakers are off, or a volume indicator unrelated to the sound from your PLAYBAR. If you have a programmable remote control, you can try the steps below. These steps will configure your remote control to send volume commands that are only recognized by the PLAYBAR so the message no longer appears when you increase or decrease the volume.

You will need to refer to the printed instructions that came with your remote control, or browse the on-screen help menu on your cable/satellite/set-top box as the specific details will vary. If you cannot locate the instructions for your remote, search the "Reference Links" on page 32. If your device or service provider is not listed there, please contact your cable service provider for additional help.

Identify an unused device key

Your remote control can likely control a variety of devices. The device keys are usually located at the top of the remote and labeled TV/Cable/CBL/STB/DVD/AUX. Identify a device key that is not currently being used (for example, the AUX key).

If your remote will not allow additional devices to be programmed, you might wish to purchase a universal remote to make it easier to control all your devices. Sonos recommends a Logitech® Harmony® universal remote. See page 27 for more information.

Program the unused device key

Programming the unused device key will add new volume commands to your remote control.

To perform this step you will need to refer to the printed instructions that came with your remote control or browse the on-screen help menu on your cable/satellite/set-top box as the specific details will vary by manufacturer. If you cannot locate the instructions, try searching the "Reference Links" on page 32 or contact your cable service provider for additional help.

- From the list of codes that can be programmed, select a Sonos code if it appears in the list.
- If Sonos does not appear in the list, select a code for any manufacturer brand **other than your TV or other devices** connected to the TV. For example if you own a Vizio TV and a Samsung Blu-ray player, choose a Panasonic code from the list.
- *DO NOT initiate an automated search for a code.*

Lock your remote control to the new volume commands

Locking volume control to the new device will ensure your remote always sends the new volume commands.

This feature is likely referred to as *volume lock* or *volume punch through* in the instructions that accompanied your remote control.

Configure your PLAYBAR to work with these new volume commands

See "Remote control setup" on page 10 for help with this step.

Verify that the problem is solved

If the problem persists, try repeating the steps above, choosing a different manufacturer brand when programming the unused device key.

Eliminating annoying messages on your TV when using a universal remote

After you disable your TV speakers, your television might display an annoying or confusing message whenever you adjust the volume on the PLAYBAR. This could be a message reminding you that your TV speakers are off, or a volume indicator unrelated to the sound from your PLAYBAR. Try the steps below to configure your universal remote so this message no longer appears when you increase or decrease the PLAYBAR's volume.

If you do not own a universal remote, Sonos recommends you purchase a Logitech® Harmony® remote.

If you are using a Logitech universal remote

If this remote is a new purchase, you will first need to set up a Logitech user account and install the Harmony Remote software. Then follow the steps below to add the PLAYBAR as a new device.

1. Use the USB cable provided by Logitech to connect your Harmony remote to your computer.

Note: If this remote is a new purchase, you will need to set up a Logitech user account and install the Harmony Remote software before proceeding.

2. Launch the Logitech Harmony Remote software or go to www.logitech.com/myharmony and login to your account. (Where you are directed depends on the Logitech universal remote model you purchased.)
3. Select the **Add Device** setting.
4. Choose one of the following options:
 - If you are using Logitech Harmony Remote software:
 - Select **Sonos** as the manufacturer, and enter **PLAYBAR** as the model name/number. If the Sonos PLAYBAR is not in their database, you will be asked to add it.
 - Confirm that you've entered the information correctly, and then save your changes.
 - If you are using My Harmony Web site:
 - Type **Sonos** as the manufacturer and **PLAYBAR** as the model name. If the Sonos PLAYBAR is not in their database, you will be asked to confirm your entry or make another choice.
 - Confirm that you've entered the information correctly, and then save your changes.

If you are using another universal remote

Please follow the instructions on page 26, "Eliminating annoying messages on your TV when using a cable, satellite, or set top box remote".

Turning Off Your Television's Speakers

During the setup process you are prompted to turn off your TV speakers so the sound comes only through the PLAYBAR. While Sonos cannot provide instructions for every television model, please try the steps below.

If you cannot find the correct setting to turn off your TV speakers, please consult the owner's guide that was packaged with your television.

1. Select the **Menu** or **Setup** button on your television's remote control (not your cable remote control).
An on-screen menu will appear.

2. Select the menu option that controls your television's **audio** functions.

Note: This menu selection is most often labeled **Audio, Sound, Tools, or Options** or may display as a musical note icon.

3. Select the appropriate setting to **turn off** your TV speakers. Depending on your TV make and model, choices may include:
 - *Off / On*
 - *External Speaker / Television Speaker*
 - **Audio System / Television Speaker**

The choice in **bold** will turn the TV speakers off.

- If none of these are applicable to your television, look for a setting that switches your TV output between variable and fixed and try switching the setting.

Can't turn off TV speakers

You should make every effort to turn off your TV's internal speakers. However some brands, including Toshiba and Dynex, may not include this setting. If you are unable to turn off the TV speakers, follow the steps below.

1. Using the volume control buttons on your television, turn the TV volume all the way down. Do not use the **Mute** button.
2. From this point forward use only the volume buttons on your Sonos controller to adjust the PLAYBAR's volume.

Indicator Light Explanations

Indicator Lights	Player State	Sonos Product	Additional Information
Solid white	Powered up and associated with a Sonos system	BRIDGE, BOOST, CONNECT™, SUB, CONNECT:AMP™, DOCK, PLAY:1, PLAY:3, PLAY:5®, PLAYBAR	If desired, when the product is in normal operation, you can turn the white status indicator light on or off by selecting White Status Light from the Room Settings menu. (The SUB indicator will reflect the same setting as the player it is paired with.)
Flashing white	Powering up	BRIDGE, BOOST, CONNECT, SUB, CONNECT:AMP, DOCK, PLAY:1, PLAY:3, PLAY:5, PLAYBAR	
Flashing green	Powered up, not yet associated with a Sonos system	BRIDGE, BOOST, CONNECT, SUB, CONNECT:AMP, DOCK, PLAY:1, PLAY:3, PLAY:5, PLAYBAR	For a SUB, this may indicate the SUB is not yet paired with a player.
Solid green	Volume set to zero or muted	CONNECT, CONNECT:AMP, PLAY:1, PLAY:3, PLAY:5, PLAYBAR	
Slowly flashing green	Surround audio is off or SUB audio is off	PLAY:1, PLAY:3, SUB	Applicable for player configured as a PLAYBAR surround speaker, or for a SUB paired with a PLAYBAR
Solid orange	During wireless setup, this occurs while the Sonos open access point is temporarily active. If you are not setting up your Sonos system, this may indicate warning mode.	CONNECT, SUB, CONNECT:AMP, PLAY:1, PLAY:3, PLAY:5, PLAYBAR	If the orange light is on AND the player's volume level automatically reduces, this indicates the player is in warning mode. <ul style="list-style-type: none"> • Press the Pause button to stop the audio • Check the vent slot for adequate cooling • Check the room temperature to make sure it's less than 104°F/ 40° C • If the player is in direct sunlight, provide shade • Allow the player to cool for several minutes and then press Play to restart the audio • If the problem does not resolve, please contact Customer Support
Rapidly flashing orange	Playback / Next Track failed	CONNECT, CONNECT:AMP, PLAY:1, PLAY:3, PLAY:5, PLAYBAR	Indicates either playback or next track was not possible

Indicator Lights	Player State	Sonos Product	Additional Information
Flashing orange	During SonosNet setup, this occurs after a button press while the product is searching for a household to join.	BRIDGE, BOOST, CONNECT, SUB, CONNECT:AMP, DOCK, PLAY:1, PLAY:3, PLAY:5, PLAYBAR	
Slowly flashing orange and white	Fault mode	CONNECT, CONNECT:AMP, PLAY:1, PLAY:3, PLAY:5, PLAYBAR, SUB	<p>If the lights are flashing orange and white AND the volume automatically mutes, this indicates the player is experiencing a fault condition.</p> <ul style="list-style-type: none"> • Press the Pause button to stop the audio • Check the room temperature to make sure it's less than 104°F/40° C • If the player is in direct sunlight, provide shade • Allow the product to cool for several minutes and then press Play to restart the audio • If the problem does not resolve, please contact Customer Support

Important Safety Information

Please read these instructions and heed all warnings. Keep them in a convenient location and make sure everyone in the household is aware of them.

Location

- Do not place the unit where it will be exposed to excessive heat (e.g., radiators, heat registers, stoves), direct sunlight, or a dusty environment (e.g., woodworking shop.)
- Do not place the unit where it will be exposed to flammable liquids and/or fumes.
- Do not place the unit in a small confined space (e.g., closet or cabinet, under a bed or sofa) where ventilation is restricted. Both ends of the PLAYBAR should be at least 1 ft. (30cm) from a wall or other obstruction.
- Protect the power cable from being walked on or pinched, particularly at plugs, convenience receptacles, and the point where it exits the product. The mains cord should be readily available to disconnect the power.
- The product should not be used near water—avoid close proximity to a bathtub, kitchen sink, laundry tub, wet basement, swimming pool, etc.
- If the unit is being wall-mounted, use the PLAYBAR Wall Mount Kit (purchased separately) and follow the instructions carefully. Improper or inadequate installation could cause your device to fall, resulting in personal injury.

Proper Ventilation

- Leave one inch of open space around the sides and above the unit to ensure proper ventilation.
- Ventilation should not be impeded by covering the ventilation openings with items such as tablecloths, curtains, or papers.
- Do not let foreign objects into the unit. If a foreign object should get into the unit, unplug the unit and contact Sonos for servicing guidance.

Usage

- Do not operate or handle the product with wet hands.
- Do not place any object on top of the product (e.g. vase, coffee cup, potted plant, books, magazines, etc.)
- Only use attachment/accessories specified by Sonos.
- Unplug the power cord during lightning storms or when unused for long periods of time.
- Never disassemble or modify the product in any way.
- If the PLAYBAR is wall-mounted, never hang from the PLAYBAR or the wall mount bracket.
- If the PLAYBAR is wall-mounted, perform safety checks on a regular basis to ensure screws remain tightened securely.

Cleaning & Maintenance

- Keep the PLAYBAR fabric free from dust, pet hair, and other fine particles.
- To clean the fabric, use a vacuum with a hose or non-moving bristle attachment. Do not vacuum with a rotating bristle attachment.

- A lint **brush** can be used to smooth out visible lines in the fabric. Do not clean fabric with a lint **roller**.
- Clean non-fabric portions of the PLAYBAR only with a dry, soft cloth. Household cleaners or solvents may damage the finish on your Sonos products.
- Do not use chemical solvents (e.g. alcohol, benzene, paint thinner) or other flammable cleaning liquids.
- Refer all servicing to Sonos qualified service personnel. Servicing is required when the unit or the power cord has been damaged in any way, if liquid or other foreign matter has fallen into the ventilation openings, or the unit has been exposed to rain or moisture.

Warning: To reduce the risk of fire or electric shock, do not expose this apparatus to rain or moisture.

Reference Links

If you need assistance with your television or one of the devices connected to your TV, you will find several user guides available online at <http://tv.manualsonline.com/>.

If you can't find what you are looking for, try one of the cable service provider links below to access additional help.

AT&T

www.att.com/esupport/

BRIGHT HOUSE NETWORKS

<http://support.brighthouse.com>

BT VISION

<http://www.bt.com/help/home>

CABLEVISION (OPTIMUM)

www.optimum.net/Support/Guides

CABLENET

<http://cablenet.com.cy/faqs/>

CHARTER

www.myaccount.charter.com/customers/support.aspx

COMCAST

<http://customer.comcast.com/help-and-support/cable-tv>

COX

www.cox.com/support/digitalcable/hdtv/

CYFROWY POLSAT

www.cyfrowypolsat.pl/

DIRECT TV

<http://support.directv.com/>

DISH NETWORK

www.mydish.com/support/manuals

KABEL DEUTSCHLANDwww.kabeldeutschland.de/info-service/**RCN**www.rcn.com/help**SKY DIGITAL**www.sky.com/helpcentre/**TIME WARNER CABLE**www.timewarnercable.com/support/**VERIZON**www22.verizon.com/Support/Residential/tv.htm**VIRGIN MEDIA**<http://help.virginmedia.com/system>

PLAYBAR Specifications

Feature	Description
Audio	
Amplifier	Nine Class-D digital amplifiers perfectly tuned to match the speakers and acoustic architecture.
Speakers	Nine amplified speakers—six midrange and three tweeters. PLAYBAR's automatic equalization means the system self-adjusts for rich, seamless performance.
3.0 Home Theater	PLAYBAR's nine-speaker design plunges you into the cinematic action with huge waves of sound that capture every whisper and footfall. The player connects to your TV with a single cable and plays all sources, including satellite boxes and game consoles.
3.1 Home Theater	Pair PLAYBAR with SUB, and with the push of a button you can add spine-curling bass to your cinematic experience—wirelessly.
5.1 Home Theater	Add PLAY:1 or PLAY:3 speakers to your PLAYBAR and SUB for a true surround sound experience. Sleek and understated with wireless control, this deeply immersive home theater experience wraps you in crystal-clear, state-of-the-art Sonos sound.
System Requirements	TV with optical audio output, broadband Internet, one Sonos product wired to router, and a Sonos Controller App.

Feature	Description
Music	
Operating systems (for stored files)	Windows® XP SP3 and higher; Mac OS X v10.6.8 and higher; NAS (Network Attached Storage) devices supporting CIFS
Music Services Supported	Sonos works seamlessly with 7 Digital®, 8 Tracks®, Amazon Cloud Player, AUPEO!, Batanga®, Beats Music, blinkbox® music, Calm Radio, Concert Vault®, Dar.fm® Record Radio, Daytrotter, Deezer, 豆瓣 FM (DoubanFM), 多米音乐 (Duomi), Google Play Music, Grooveshark, Hearts of Space®, hotelradio.fm™, iHeartRadio, JB Hi-Fi NOW, JUKE, Last.fm™, Live365, MLB.com Gameday Audio, Murfie, Napster by Rhapsody, Netease, Pandora®, Qobuz, QQ 音乐 (QQ Music), radionomy, rara.com, Rdio™, Rhapsody®, RUSC, Shuffler.fm, simfy®, SiriusXM® Internet Radio, Slacker, Songl, Songza®, SoundCloud®, Spotify®, Stitcher SmartRadio™, TDC Play Musik®, The Hype Machine®, TuneIn, WiMP, Xiami, YouMusic®, Zdigital, and downloads from any service offering DRM-free tracks (service availability varies by region)
Internet Radio Supported	Streaming MP3, WMA
Audio Formats Supported	Support for compressed MP3, iTunes Plus, WMA (including purchased Windows Media downloads), AAC (MPEG4), AAC+, Ogg Vorbis, Audible (format 4), Apple Lossless, Flac (lossless) music files, as well as uncompressed WAV and AIFF files. Native support for 44.1kHz sample rates. Additional support for 48kHz, 32kHz, 24kHz, 22kHz, 16kHz, 11kHz, and 8kHz sample rates. Note: Apple "Fairplay", AAC Enhanced and WMA Lossless formats not currently supported. Previously purchased Apple "Fairplay" DRM-protected songs may be upgraded. See Apple for details.
Album Art Supported	JPEG, PNG, BMP, GIF
Playback Modes	Crossfade, shuffle, repeat
Playlists Supported	iTunes®, WinAmp®, Windows Media Player®, and MusicMatch™ (.m3u, .pls, .wpl)
Networking	
Ethernet Port (2)	A single Ethernet port can connect PLAYBAR to a wired home network. A second Ethernet port can be used to share the network connection with other devices in your network.
Wireless Connectivity	Works on your home WiFi network with any 802.11b/g, 2.4GHz broadcast capable router Also works on SonosNet™, a secure AES encrypted, peer-to-peer wireless mesh network dedicated exclusively for your Sonos system to reduce WiFi interference (If pairing surround speakers or a SUB with your PLAYBAR, you'll need to connect a Sonos product to your router with an Ethernet cable.)
SonosNet Extender	Functions to extend and enhance the power of SonosNet 2.0
General	
Side Panel Buttons	Volume Up, Volume Down and Mute
Side Panel LEDs	Indicates PLAYBAR status

Feature	Description
Power Supply	100 - 240 VAC, 50/60 Hz, auto-switchable
Dimensions (H x W x D)	3.35" (H) x 35.43" (W) x 5.51" (D), 85mm (H) x 900mm (W) x 140 mm (D)
Weight	11.9 lbs (5.4kgs)
Operating Temperature	32°F to 104°F (0°C to 40°C)
Storage Temperature	4°F to 158°F (-20°C to 70°C)
Package Contents	PLAYBAR, AC power cord, optical audio cable, quickstart guide and legal booklet.
Multiple Orientations	Mount PLAYBAR on the wall either above or below your television, or lay flat on your television table.
Control	Control PLAYBAR volume and mute using your existing TV, cable or universal remote. Or download a free Sonos app to control PLAYBAR from your smartphone, tablet, PC or Mac computer.
Supported Devices	PLAYBAR works with all amplified and non-amplified Sonos products. PLAYBAR connects to your TV using a single optical cable and plays all sources connected to the TV, including cable boxes and game consoles.

* Specifications subject to change without notice.

Regulation Information

USA

This equipment has been tested and found to comply with the limits for a Class B digital device, pursuant to part 15 of the FCC Rules. These limits are designed to provide reasonable protection against harmful interference in a residential installation. This equipment generates, uses and can radiate radio frequency energy and, if not installed and used in accordance with the instructions, may cause harmful interference to radio communications. However, there is no guarantee that interference will not occur in a particular installation. If this equipment does cause harmful interference to radio or television reception, which can be determined by turning the equipment off and on, the user is encouraged to try to correct the interference by one or more of the following measures:

- All Sonos devices have in-products antennas. Users cannot reorient or relocate the receiving antenna without modifying the product
- Increase the separation between the equipment and receiver.
- Connect the equipment into an outlet on a circuit different from that to which the receiver is connected.

Caution: Modifications not expressly approved by the manufacturer may void the user's authority to operate the equipment under FCC rules.

The device for operation in the band 5150-5250 MHz is only for indoor use to reduce the potential for harmful interference to co-channel mobile satellite systems.

Canada

This Class B digital apparatus complies with Canadian ICES-003 and RSS-210. Operation is subject to the following two conditions: (1) this device may not cause interference, and (2) this device must accept any interference, including interference that may cause undesired operation of the device.

The installer of this radio equipment must ensure that the product is located such that it does not emit RF field in excess of Health Canada limits for the general population; consult Safety Code 6, obtainable from Health Canada's Web site www.hc-sc.gc.ca/rpb. As mentioned before, the installer cannot control the antenna orientation. However, they could place the complete product in a way that causes the problem mentioned above.

The device for operation in the band 5150-5250 MHz is only for indoor use to reduce the potential for harmful interference to co-channel mobile satellite systems.

Be advised that high-power radars are allocated as primary users (i.e. priority users) of the bands 5250-5350 MHz and 5650-5850 MHz and that these radars could cause interference and/or damage to LE-LAN devices.

Canada

Cet appareil numérique de classe B est conforme aux normes NMB-003 et CNR-210 en vigueur au Canada. Son fonctionnement est soumis aux deux conditions suivantes : (1) Cet appareil ne doit pas créer d'interférences nuisibles. (2) Cet appareil doit tolérer toutes les interférences reçues, y compris les interférences pouvant entraîner un fonctionnement indésirable.

L'installateur du présent matériel radio doit veiller à ce que le produit soit placé ou orienté de manière à n'émettre aucun champ radioélectrique supérieur aux limites fixées pour le grand public par le ministère fédéral Santé Canada ; consultez le Code de sécurité 6 sur le site Web de Santé Canada à l'adresse : www.hc-sc.gc.ca/rpb. Comme indiqué auparavant, l'installateur ne peut pas contrôler l'orientation de l'antenne. Il peut néanmoins placer le produit tout entier de manière à provoquer le problème décrit ci-dessus.

Les dispositifs fonctionnant dans la bande 5150-5250 MHz sont réservés uniquement pour une utilisation à l'intérieur afin de réduire les risques de brouillage préjudiciable aux systèmes de satellites mobiles utilisant les mêmes canaux.

Les utilisateurs de radars de haute puissance sont désignés utilisateurs principaux (c.-à-d., qu'ils ont la priorité) pour les bandes 5250-5350 MHz et 5650-5850 MHz et que ces radars pourraient causer du brouillage et/ou des dommages aux dispositifs LAN-EL.

Europe

Sonos declares that this product herewith complies with the requirements of the EMC Directive 2004/108/EC, Low Voltage Directive 2006/95/EC, Eco-Design Directive 2005/32/EC, RoHS Directive 2011/65/EU and the R&TTE Directive 1999/5/EC when installed and used in accordance with the manufacturer's instructions. A copy of the full Declaration of Conformance may be obtained at www.sonos.com/support/policies.

⚠ Attention In France, operation is limited to indoor use within the band 5150-5350 MHz.

SonosNet is the propriety wireless mesh network architecture designed to provide robust transmission of high fidelity streaming digital music. All Sonos players within the SonosNet mesh network act as both a client and access point simultaneously. Each Sonos player expands the range of SonosNet mesh network because while each device must be within range of at least one other Sonos player, they do not need to be within range of a central access point. In addition to extending the range between Sonos products, SonosNet can extend the range of other data networking devices within the home, such as Android devices directly connected to SonosNet. Due to the high network availability requirements of the SonosNet mesh network, Sonos players do not have a standby or off mode other than removing the power cord from the AC mains.

RF Exposure Requirements

To comply with FCC and Industry Canada exposure essential requirements, a minimum separation distance of 20cm (8 inches) is required between the equipment and the body of the user or nearby persons.

Recycling Information



This symbol on the product or on its packaging indicates that this product shall not be treated as household waste. Instead please deliver it to the applicable collection point for the recycling of electrical and electronic equipment. By recycling this product correctly, you will help conserve natural resources and prevent potential negative environmental consequences. For more detailed information about recycling of this product, please contact your local city office, your household waste disposal service or the shop where you purchased the product.