



Pressure and Vacuum Switches for Process Applications

Form 216

SOR Pressure Switches

are rugged field-mounted instruments. The pressure sensing element of the SOR pressure switch is a force-balance, piston-actuated assembly. The sensing element is sealed by a flexible diaphragm and a static o-ring. A wide selection of wetted parts materials for media compatibility and containment are available. A metal diaphragm may be welded to the pressure port for certain applications, thereby eliminating the o-ring.

Application Information

The SOR pressure switches in this catalog are suitable for a variety of process applications. Basic models with standard wetted parts are normally suitable for air, oil, water and non-corrosive processes. See the Quick Selection Guide on pages 4 and 5. Specific application requirements can normally be met by selecting optional components, such as switching elements, diaphragm systems and pressure ports. See How to Order on page 3. Certain applications may require customized specials. Consult the SOR representative in your area or the factory.

This catalog describes switches that are:

- General Purpose
- Weathertight
- Conventional Explosion Proof

Other specific types of switches available through your SOR representative are:

- Hermetically Sealed (for hazardous locations)
- Pivot Seal (for high shock pressures and cycle rates)
- Differential Pressure
- Temperature (remote and direct mount)
- Electronic and Mechanical Level
- Electronic Pressure

Design and specifications are subject to change without notice.

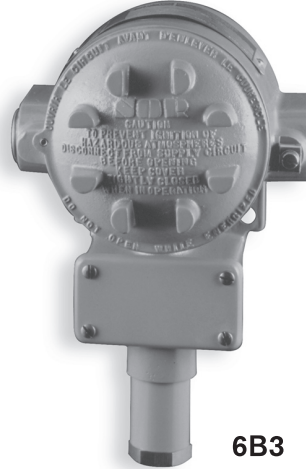

6B3



6NN



12L

Features and Benefits

Complete Product Line

- Standard models and customized specials cover pressure range from 30 inches Hg VAC to 4000 psi.

Robust Construction

- Rugged, high-cycle rate tolerance, long life, not critical to vibration, high overrange and proof pressures, excellent corrosion resistance to hostile environments.

Instrument Quality

- High resolution of Set Points, high repeatability, narrow dead band, negligible temperature effect.

Wetted Parts

- Wide selection materials, process connection configurations and sizes. Optional "fire-safe" pressure sensor.

Snap-Action Electrical Switching

- Wide selection UL Listed and CSA Certified switching elements for AC and DC service. Optional "hermetically sealed" capsule for hazardous and hostile environments.

Field Adjustable

- Self-locking adjustment, no special tools required. No-charge factory calibration.

Cost Effective

- Simple and fast installation without special tools, long service life, no required periodic service or spare parts.

UL Listed, CSA Certified, ATEX Certified, FM, JIS/RIIS Approved Models

- Meets most code and customer requirements.

Built-In Quality

- Rigid quality standards maintained from raw material to finished product.

Service

- Factory sales engineers and area SOR representatives provide effective and prompt worldwide service.

Delivery

- Routine shipments 7 to 10 working days. Emergency shipments via same day air.

Warranty

- 3 years from date of manufacture.

Model Number System

6NN-K5-M4-C2A-YY



Quick Selection Guide

Basic SOR pressure switches with standard wetted parts are normally suitable for air, oil, water and non-corrosive processes. The Quick Selection Guide on pages 4 and 5 shows these basic SOR pressure and vacuum switches. Corrosive service and particular customer requirements may require optional components. Refer to How to Order section below to build a customized model number or the dedicated page to locate optional components, such as switching elements, diaphragm systems, pressure ports and accessories. Each position in the model number, except Accessories, must have a designator.

Applications

SOR pressure switches in this catalog are suitable for a wide variety of continuous pressure applications. Specific application requirements can normally be met by selecting optional components, such as, switching elements, diaphragm systems and pressure ports. Certain applications may require customized specials. Consult the SOR representative in your area or the factory.

How to Order

Information and data in this catalog are formatted to provide a convenient guide to assist instrument engineers, plant engineers and end users in selecting pressure switches for their unique applications.

Steps 1 through 5 are required. Step 6 is optional. Orders must have complete Model Numbers, i.e. each component must have a designator.

Step 1: Select **Piston-Spring** adjustable range/Set Point from Specifications (pages 7 & 8). (Piston/Spring combination determines adjustable range.)

Step 2: Select **Housing** for type of pressure switch and service (page 9).

Step 3: Select electrical **Switching Element** for electrical service (pages 10 & 11).

Step 4: Select **Diaphragm and O-Ring** for process compatibility and containment (pages 12 & 13).





Step 5: Select **Pressure Port** for process compatibility and connection (page 14).

Step 6: Select **Accessories** required for service (page 16).

Pressure and Vacuum Switches

Quick Selection Guide - Pressure

Basic SOR pressure switches with standard wetted parts are normally suitable for air, oil, water and non-corrosive processes. Corrosive service and particular customer requirements may require optional components. Refer to How to Order on page 3 to locate optional components, such as, housing, switching elements, diaphragm systems, pressure ports and accessories. Each position in the model number, except Accessories, must have a designator.

 <p>Weathertight</p>	Weathertight Model Number	Adjustable Range (Increasing pressure) psi (in. wc)	Typical Dead Band psi (in. wc)	Explosion Proof Model Number	 <p>Explosion Proof</p>
	12NN - N66 - N4 - B1A	(0.6 to 2.5)	(0.4)	12L - N66 - N4 - B1A	
	12NN - K614 - N4 - B1A	(2.5 to 45.0)	(0.8)	12L - K614 - N4 - B1A	
	12NN - K2 - N4 - B1A	0.4 to 2.0	0.1	12L - K2 - N4 - B1A	
	12NN - K4 - N4 - B1A	0.5 to 6.0	0.1	12L - K4 - N4 - B1A	
	12NN - K5 - N4 - B1A	0.75 to 12	0.1	12L - K5 - N4 - B1A	
	12NN - K45 - N4 - B1A	1 to 16	0.15	12L - K45 - N4 - B1A	
Piston 12		Overrange 200 (psi)		Proof 400 (psi)	
 <p>Weathertight</p>	Weathertight Model Number	Adjustable Range (Increasing pressure) psi	Typical Dead Band psi	Explosion Proof Model Number	 <p>Explosion Proof</p>
	4NN - K2 - N4 - B1A	2 to 8	0.2	4L - K2 - N4 - B1A	
	4NN - K4 - N4 - B1A	2 to 25	0.3	4L - K4 - N4 - B1A	
	4NN - K5 - N4 - B1A	3 to 50	0.4	4L - K5 - N4 - B1A	
	4NN - K45 - N4 - B1A	4 to 75	0.5	4L - K45 - N4 - B1A	
Piston 4		Overrange 750 (psi)		Proof 1000 (psi)	

Standard Construction

- Housing: NN - aluminum; L - cast iron
- Switching Element: SPDT; N - 10 amps @ 250 VAC; K - 15 amps @ 250 VAC
- Diaphragm & O-ring: N4 - primary (wetted) diaphragm, TCP; o-ring (wetted) Buna-N
- Pressure Port: 1/4" NPT(F); B1A - aluminum; F1A - carbon steel

Notes

1. See balance of catalog for construction options.
2. Dead band values are expressed as typical expected at mid-range for a particular model number. See Dead Band Considerations on page 8.
3. Design and specifications subject to change without notice.

Pressure and Vacuum Switches

Quick Selection Guide - Pressure



Weathertight

Weathertight Model Number	Adjustable Range (Increasing pressure) psi	Typical Dead Band psi	Explosion Proof Model Number
6NN - K2 - N4 - F1A	7 to 30	0.5	6L - K2 - N4 - F1A
6NN - K3 - N4 - F1A	12 to 100	0.9	6L - K3 - N4 - F1A
6NN - K5 - N4 - F1A	20 to 180	1.4	6L - K5 - N4 - F1A
6NN - K45 - N4 - F1A	25 to 275	1.9	6L - K45 - N4 - F1A
5NN - K3 - N4 - F1A	25 to 240	2.2	5L - K3 - N4 - F1A
5NN - K5 - N4 - F1A	35 to 375	3.1	5L - K5 - N4 - F1A
5NN - K45 - N4 - F1A	45 to 550	3.9	5L - K45 - N4 - F1A
9NN - K4 - N4 - F1A	100 to 500	5.3	9L - K4 - N4 - F1A
9NN - K5 - N4 - F1A	200 to 1000	9.2	9L - K5 - N4 - F1A
9NN - K45 - N4 - F1A	200 to 1750	15	9L - K45 - N4 - F1A
1NN - K45 - N4 - F1A	500 to 4000	98	1L - K45 - N4 - F1A
Piston 6, 5 9 1	Overrange 1500 (psi) 2500 5000		Proof 2500 (psi) 6000 6000



Explosion Proof

Standard Construction

- Housing: NN - aluminum; L - cast iron
- Switching Element: SPDT; K - 15 amps @ 250 VAC
- Diaphragm & O-ring: N4 - primary (wetted) diaphragm, TCP; o-ring (wetted) Buna-N
- Pressure Port: 1/4" NPT(F); B1A - aluminum; F1A - carbon steel

Notes

1. See balance of catalog for construction options.
2. Dead band values are expressed as typical expected at mid-range for a particular model number. See Dead Band Considerations on page 8.
3. Design and specifications subject to change without notice.

Quick Selection Guide - Vacuum



Weathertight

Weathertight Model Number	Adjustable Range Vacuum-0-pressure in. Hg (in. wc)	Typical Dead Band in. Hg (in. wc)	Explosion Proof Model Number
52NN - K116 - N4 - B1A	(20 - 0 - 20)	(0.9)	52L - K116 - N4 - B1A
52NN - K117 - N4 - B1A	(40 - 0 - 40)	(1.1)	52L - K117 - N4 - B1A
54NN - K117 - N4 - B1A	15 - 0 - 15	0.5	54L - K117 - N4 - B1A
54NN - K118 - N4 - B1A	30 - 0	0.5	54L - K118 - N4 - B1A
56NN - K216 - M2 - F1A	30 - 0 - 20	1.0	56L - K216 - M2 - F1A
56NN - K316 - M2 - F1A	30 - 0 - 160	1.4	56L - K316 - M2 - F1A
Piston 52 54 56	Overrange 200 (psi) 750 1500		Proof 400 (psi) 1000 2500



Explosion Proof

Standard Construction

- Housing: NN - aluminum; L - cast iron
- Switching Element: SPDT; K - 15 amps @ 250 VAC
- Diaphragm & O-ring: N4 - primary (wetted) diaphragm, TCP; o-ring (wetted) Buna-N. Piston 56 primary (wetted) diaphragm, 316SS.
- Pressure Port: 1/4" NPT(F); B1A - aluminum; F1A - carbon steel

Notes

1. See balance of catalog for construction options.
2. Dead band values are expressed as typical expected at mid-range for a particular model number. See Dead Band Considerations on page 8.
3. Design and specifications subject to change without notice.

SOR recognizes that there is no industry convention with respect to terminology and definitions pertinent to pressure switches. This glossary applies to SOR pressure switches.

Pressure Switch

A bi-stable electromechanical device that actuates/deactuates one or more electrical switching element(s) at a predetermined discrete pressure/vacuum (Set Point) upon rising or falling pressure/vacuum.

Adjustable Range

The span of pressure between upper and lower limits within which the pressure switch can be adjusted to actuate/deactuate. It is expressed for increasing pressure.

Set Point

That discrete pressure at which the pressure switch is adjusted to actuate/deactuate on rising or falling pressure. It must fall within the adjustable range and be called out as increasing or decreasing pressure.

Dead Band

The difference in pressure between the increasing Set Point and the decreasing Set Point. It is expressed as typical, which is an average with the increasing Set Point at mid-range for a pressure switch with the standard K switching element. It is normally fixed (non-adjustable).

Fire-Safe

The ability of a welded seal pressure sensor to contain the process at elevated temperatures up to 1200°F at the rated overrange pressure, unsupported by the body of the pressure switch.

Hermetically Sealed

A welded steel capsule with glass-to-metal, factory-sealed electrical leads that isolates the electrical switching element(s) from the environment.

Overrange

The maximum input pressure that can be continuously applied to the pressure switch without causing permanent change of Set Point, leakage or material failure.

Proof Pressure

The maximum input pressure that can be continuously applied to the pressure switch without causing leakage or catastrophic material failure. Permanent change of Set Points may occur, or the device may be rendered inoperative.

Repeatability

The ability of a pressure switch to successively operate at a Set Point that is approached from a starting point in the same direction and returns to the starting point over three consecutive cycles to establish a pressure profile. Repeatability on SOR switches will be smaller than 1% of full scale per ISA/ANSI S51.1.

SPDT Switching Element

Single-Pole, Double Throw (SPDT) has three connections: C – Common, NO – Normally Open and NC – Normally Closed, which allows the switching element to be electrically connected to the circuit in either NO or NC state.

DPDT Switching Element

DPDT is two synchronized SPDT switching elements which actuate together at increasing Set Point and deactuate together at decreasing Set Point. Discrete SPDT switching elements allow two independent circuits to be switched; i.e., one AC and one DC.

The synchronization linkage is factory set, and is not field adjustable. Synchronization is verified by connecting test lamps to the switching elements and observing them go “On” simultaneously at actuation and “Off” simultaneously at deactuation.

Pressure and Vacuum Switches

Step 1: Piston/Spring 6NN-K5-M4-C2A-YY

This table is a listing of piston-spring combinations and the corresponding adjustable ranges, dead bands, overrange and proof pressures. Adjustable range is expressed for increasing pressure; the Set Point must be within the adjustable range. Dead band is expressed as typical. See Dead Band Considerations on page 8.

Piston-Spring Designators	Adjustable Range ⁴		Typical Dead Band ¹		Overrange		Proof	
	psi (in. wc)	bar [mbar]	psi (in. wc)	bar [mbar]	psi	bar	psi	bar
12 - 66 ²	(0.6 to 2.5)	[1.5 to 6.2]	(0.4)	[1]	200	14	400	28
12 - 614 ³	(2.5 to 45)	[6.2 to 110]	(0.8)	[2]				
12 - 2	0.4 to 2.0	[30 to 140]	0.1	[7]				
12 - 4	0.5 to 6.0	[35 to 415]	0.1	[7]				
12 - 5	0.75 to 12	[50 to 830]	0.1	[7]				
12 - 45	1 to 16	[70 to 1100]	0.15	[10]				
4 - 2	2 to 8	[140 to 550]	0.2	[15]	750	50	1000	70
4 - 4	2 to 25	0.14 to 1.7	0.3	[20]				
4 - 5	3 to 50	0.2 to 3.5	0.4	[30]				
4 - 45	4 to 75	0.3 to 5	0.5	[35]				
6 - 2	7 to 30	0.5 to 2	0.5	[35]	1500	100	2500	170
6 - 3	12 to 100	0.8 to 7	0.9	[60]				
6 - 5	20 to 180	1.4 to 12	1.4	[95]				
6 - 45	25 to 275	1.7 to 19	1.9	0.1				
5 - 3	25 to 240	1.7 to 16	2.2	0.15				
5 - 5	35 to 375	2.4 to 26	3.1	0.2				
5 - 45	45 to 550	3.1 to 38	3.9	0.25	2500	170	6000	410
9 - 4 ⁶	100 to 500	7 to 35	5.3	0.5				
9 - 5 ⁶	200 to 1000	14 to 70	9.2	0.6				
9 - 45 ⁶	200 to 1750	14 to 120	15	1				
1 - 45 ⁶	500 to 4000	35 to 275	98	7	5000	340	6000	410

1. Dead band values are expressed as typical expected at mid-range with the standard K switching element assembly installed. When optional switching elements are specified, corresponding dead band multipliers shown on pages 8 and 10 must be applied.
2. The 12/66 piston/spring combination is available with the N switching element only.
3. Adjustable range becomes 10 to 45 in. wc whenever switching elements other than K, KA, W or D are used.
4. Special ranges may be possible. Consult the factory or the SOR representative in your area.
5. Diaphragms may have an additional effect on dead band. See page 13, Note 9.
6. Diaphragm life may be limited by using T or H switching elements with Numbers 1 and 9 pistons.
7. Metric bar (mbar) values are practical equivalents of the reference English values; not necessarily exact mathematical conversions. This data appears on the product nameplate when metric engineering units are specified.
8. A breather drain (Accessory KK, see page 16) should be specified when low pressure adjustable ranges are used in environments with significant ambient temperature changes.

Pressure and Vacuum Switches

Step 1: Piston/Spring 52NN-K116-M4-C2A-YY

This table is a listing of piston–spring combinations and the corresponding adjustable ranges, dead bands, overrange and proof pressures. SOR vacuum switches are compound; they will operate in either vacuum or pressure modes. Adjustable range is expressed from maximum vacuum decreasing to zero gauge and increasing to maximum pressure. Dead band is expressed as typical. See dead band considerations below. The Set Point must be within the adjustable range. A vacuum switch is generally better suited than a pressure switch for Set Points very near zero gauge.

Piston-Spring	Adjustable Range ² (Vacuum - 0 - Pressure)		Typical Dead Band ¹ (Vacuum Mode)		Overrange		Proof	
	in. Hg (in. wc)	bar [mbar]	in. Hg (in. wc)	mbar	psi	bar	psi	bar
52 - 116	(20 - 0 - 20)	[50 - 0 - 50]	(0.9)	2	200	14	400	28
52 - 117	(40 - 0 - 40)	[100 - 0 - 100]	(1.1)	3				
54 - 117	15 - 0 - 15	0.5 - 0 - 0.5	0.5	17	750	50	1000	70
54 - 118	30 - 0	1.0 - 0	0.5	17				
56 - 216	30 - 0 - 20	1.0 - 0 - 0.7	1.0	34	1500	100	2500	170
56 - 316	30 - 0 - 160	1.0 - 0 - 5.4	1.4	47				

Notes

- Dead band values are expressed as typical expected at mid-range with the standard K switching element assembly installed. When optional switching elements are specified, corresponding dead band multipliers shown below must be applied.
- Special ranges may be possible. Consult the factory or the SOR representative in your area.
- Diaphragms may have an additional effect on dead band. See page 13, Note 9.
- Metric bar (mbar) values are practical equivalents of the reference English values; not necessarily exact mathematical conversions. This data appears on the product nameplate when metric engineering units are specified.

Dead Band Considerations



- Dead band values are expressed as typical expected at mid-adjustable range using the standard K switching element. When optional switching elements are specified, corresponding dead band multipliers must be applied.
- Dead bands are fixed (non-adjustable), except when T or H switching elements are used.
- Dead band can be adjustable by selecting T or H switching element. (Diaphragm life may be limited when used with Numbers 1 and 9 pistons.)
- Dead band multipliers must be applied to the typical dead band value shown for piston-spring combination in specifications, pages 7 and 8, whenever optional switching elements other than K, KA or W are used.
- Dead band can be widened by selecting an optional switching element with a multiplier greater than 1.0.
Example: Model 6NN-G5-M4-C2A-YY
Typical Dead Band 1.4 psi
G-Switching Element multiplier = 3
Corrected Typical Dead Band 1.4 x 3 = 4.2 psi

Switching Element Designators	Dead Band Multiplier
K, KA, N, W	1.0
D, E, J, M, Y	1.5
BD	2.5
A, B, EF, G, JF	3.0
L, YY	3.5
AF, CA, EE	4.0
C, JJ, S	5.0
EG, JG	5.5
AA, BB, GG, KK	6.0
LL	6.5
AG	8.5
T	2.5 to 6.5
H	1.0 to 3.0







Pressure and Vacuum Switches

Step 2: Housing 6NN-K5-M4-C2A-YY







General Purpose NEMA 1

 <p>PP</p> <p>Electrical: 3/4" NPT(F)-Right Material: Aluminum See Agency Listings pages 17 & 18 See Switching Element Groups 1, 2, 3, 4 below</p>	 <p>P3</p> <p>Electrical: 3/4" NPT(F)-Left, Right Material: Aluminum See Switching Element Groups</p>	 <p>H3</p> <p>Electrical: Exposed contacts Material: Aluminum Open bracket with exposed switching element-does not meet NEMA 1 See Switching Element Groups 1, 3 below.</p>
------------------------------------------------------------------------------------------------------------------------------------------------------------------------------------------------------------------------------------------------------------	-------------------------------------------------------------------------------------------------------------------------------------------------------------------------------------------------------	-----------------------------------------------------------------------------------------------------------------------------------------------------------------------------------------------------------------------------------------------------------------------------------

Weathertight NEMA 4, 4X, IP65

 <p>NN</p> <p>Electrical: 3/4" NPT(F)-Right Material: Aluminum See Agency Listings pages 17 & 18 See Switching Element Groups</p>	 <p>N3</p> <p>Electrical: 3/4" NPT(F)-Left, Right Material: Aluminum See Agency Listings pages 17 & 18 See Switching Element Groups 1, 2, 3, 4 below.</p>	 <p>N4</p> <p>Electrical: 3/4" NPT(F)-Right Material: Aluminum Cover: Heavy Duty with Viton gasket See Agency Listings pages 17 & 18 See Switching Element Groups 1, 2, 3, 4 below.</p>
 <p>N6</p> <p>Electrical: 3/4" NPT(F)-Right Material: Carbon Steel See Switching Element Groups 1, 3 below.</p>	 <p>RN RM</p> <p>Electrical- RN: 3/4" NPT(F)-Right Electrical- RM: M20 x 1.5-Right Six-place compression type terminal block Material: Aluminum See Agency Listings pages 17 & 18 See Switching Element Groups 1, 2, 3, 5 below.</p>	 <p>RT RS</p> <p>Electrical- RT: 3/4" NPT(F)-Right Electrical- RS: M20 x 1.5-Right Six-place compression type terminal block Material: 316SS See Agency Listings pages 17 & 18 See Switching Element Groups 1, 2, 3, 5 below.</p>
		 <p>RB</p> <p>Electrical: 3/4" NPT(F)-Right Manual reset only Six-place compression type terminal block Material: Aluminum See Agency Listings pages 17 & 18 See Switching Element Group 6 below.</p>

Conventional Explosion Proof

 <p>*L</p> <p>UL Listed Class I, Group C & D; Class II, Group E, F, G; Division 1 & 2 as an outlet box only Electrical: 3/4" NPT(F)-Right Material: Cast Iron Weathertight with Option CG See Switching Element Groups 1, 3 below.</p>	 <p>*LC</p> <p>UL Listed Class I, Group C & D; Class II, Group E, F, G; Division 1 & 2 as an outlet box only Electrical: 3/4" NPT(F)-Right Six-place compression type terminal block with Option LL Material: Copper-free aluminum Weathertight See Switching Element Groups 1, 2, 3 below.</p>	 <p>*B3 Electrical: 3/4" NPT(F)-Left, Right Material: Aluminum</p> <p>*B4 Electrical: M20 x 1.5-Left, Right Material: Aluminum</p> <p>*B5 Electrical: M20 x 1.5-Left, Right Material: Cast Iron</p> <p>*B6 Electrical: 3/4" NPT(F)-Left, Right Material: Cast Iron</p> <p>Switching Element Groups 1, 2, 3, 5 below.</p>
 <p>*S</p> <p>UL Listed Class I, Group C & D; Class II, Group E, F, G; Division 1 & 2 as an outlet box only Electrical: 3/4" NPT(F)-Left, Right, Top Material: Cast Iron Weathertight with Option CG See Switching Element Groups 1, 3, 6 below.</p>	 <p>*SC</p> <p>UL Listed Class I, Group C, D; Class II, Group E, F, G; Division 1 & 2 as an outlet box only Electrical: 3/4" NPT(F)-Right, Left, Top Six-place compression type terminal block with Option LL Material: Copper-free aluminum Weathertight See Switching Element Groups 1, 2, 3, 6 below.</p>	
 <p>*TA</p> <p>Class I, Group A, B, C, D; Class II, Group E, F, G; Division 1 & 2 as an outlet box only Electrical: 3/4" NPT(F)-Left, Right, Top Material (Housing): Cast Iron Material (Cover): Aluminum Line Mounted. Weathertight with Option CG. See Switching Element Groups 1, 3 below.</p>	 <p>*J4</p> <p>Separate electrical and set point adjustment compartments. Six-place compression type terminal block. Explosion Proof IIB-T4. Material: Aluminum Right hand electrical outlet: PF 3/4" (F) See Switching Element Groups 1, 2, 3 below.</p>	

*Not recommended for direct mount where vibration is expected. Housing should be securely mounted to a flat surface (bulkhead or panel rack) or pipe stanchion.

**Consult the factory.

Switching Element Group/Housing Compatibility	Group 1 A, AA, B, BB, BD*, C*, CA* E, EE, G, J, JJ, K, KA, L, N, S, W, Y	Group 2 GG, KK, LL, YY	Group 3 T	Group 4 H	Group 5 AF, AG, EF, EG, JF, JG	Group 6 D, M
-----------------------------------------------	-----------------------------------------------------------------------------	---------------------------	--------------	--------------	-----------------------------------	-----------------

*BD only available with RN, RT housings

*C micro switch is not available in L, S and TA housings.

*CA micro switch only available in PP, NN, N3 and N4 housings

Pressure and Vacuum Switches

Step 3: Switching Element

6NN-K5-M4-C2A-YY

Switching Element Service	Electrical Contact Type	Electrical Connection Type	AC Rating		DC Rating Resistive				Dead Band Multiplier		Designator	
			Volts	Amps	Volts	Amps	Volts	Amps	SPDT	DPDT	SPDT	DPDT
Normal Service AC	Single Switching Element SPDT - (1) SPDT Double Switching Element DPDT - (2) SPDT Synchronized actuation/deactuation at increasing/decreasing set points.	K, KA, G, L, C, N, S, Y, W Switching Elements - Screw Terminals. All other Switching Elements - 18" 18 AWG Color-Coded Wire Leads except when terminal blocks are specified. T & H Switching Elements - Consult Factory.	250	15	125	0.4*	30	5*	1.0	6.0	K	KK
Low Power Gold Contacts			125	1	-	-	28	1*	1.0	-	KA	-
Wide Dead Band AC			125	1	-	-	30	1	1.5	5.0	J	JJ
AC or DC			250	15	125	0.5	-	-	3.0	6.0	G	GG
Wide Dead Band DC			250	11	125	0.5*	30	5	3.0	6.0	A	AA
Narrow Dead Band DC			250	15	125	0.5	30	10*	3.5	6.5	L	LL
Very Wide Dead Band DC			250	5	125	0.5*	30	5*	1.5	4.0	E	EE
Very High Capacity DC Magnetic Blow-Out			250	15	125	0.5	-	-	5.0	-	C	-
Hi Ambient Temperature Rating - 400°F			125	10	125	1.5 Minimum 10.0 Maximum	-	-	5.0	-	S	-
Low Pressure Service 12-66 only			250	5	125	0.3	-	-	3.0	6.0	B	BB
Wide Adjustable Dead Band			250	5	125	0.5*	-	-	1.5	3.5	Y	YY
Narrow Adjustable Dead Band			250	5	125	0.3*	-	-	1.0	-	W	-
Manual Reset - For use with increasing pressure set points			250	10	-	-	-	-	1.0	-	N	-
Manual Reset - For use with decreasing pressure set points			250	15	125	0.4*	-	-	2.5 to 6.5	-	T	-
Hermetically Sealed Switching Element			250	15	-	-	-	-	1.0 to 3.0	-	H	-
Hermetically Sealed Gold Contacts			250	15	125	0.5	-	-	1.5	-	D	-
FM Approved Service Only			250	11	125	0.5*	30	5	4.0	8.5	AF	AG
Explosion Proof EEx d IIC T6			250	5	125	0.5*	30	5*	3.0	5.5	EF	EG
			125	1	-	-	30	1	3.0	5.5	JF	JG
			250	22	125	0.5	-	-	4.0	-	CA	-
	250	7	250	0.25	30	7	2.5	-	BD	-		

Cross reference compatibility chart on page 9 to ensure that switching element will fit in housing.

Review notes on page 11 for more details.

Notes

- Double switching elements have wire leads except when supplied in housings RB, RM, RN, RS, RT, B3, B4, B5, B6 and J4. Terminal blocks are standard in these housings.
- Dead band multipliers must be applied to the typical dead band figures given in the specification tables on pages 7 and 8.
- Switching element ambient temperature limits:

-65 to 400°F	(-54 to 200°C)	B, Y, W
-65 to 250°F	(-54 to 120°C)	A, E, & J
-40 to 167°F	(-40 to 75°C)	AF, AG, EF, EG, JF, JG
-13 to 158°F	(-25 to 70°C)	BD
-65 to 180°F	(-54 to 80°C)	All others
- The hermetically sealed switching element capsule is ATEX Approved, UL Listed, CSA Certified and SAA Approved as an explosion proof snap switch according to the following table with conditions and exceptions specified in Note 3.
- Switching elements W, & Y have Elgiloy springs.
- Certain switching elements can handle greater voltage and/or amperage. Consult the factory should your requirements exceed catalog values. All switching elements above except BD are UL Recognized and CSA Certified. The DC current ratings marked with an asterisk (*) are not UL Listed but have been verified by testing and/or experience.

CAUTION: The switching element assembly has been precisely positioned in the housing at the factory for optimum performance. Any inadvertent movement or replacement in the field will degrade performance, could render the device inoperative, and can void the warranty unless factory authorized procedures are followed.

Agency	Hazardous Location Conditions	Designator
UL Listed CSA Certified	Class I, Group A, B, C, D Class II, Group E, F, & G; Division 1 & 2	AF, EF, AG, EG, JF, JG
SAA Approved	Ex s IIC T6 IP65 Class I, Zone I DIP T6 IP65	AF, EF, AG, EG
ATEX Approved	II 2 G EEx m II	AF, EF, AG, EG, JF, JG

Pressure and Vacuum Switches

Step 4: Diaphragm & O-Ring

6NN-K5-M4-C2A-YY

Notes

1. N4 diaphragm system is standard, but requires a designator in the model number. It is normally suitable for air, oil, water and noncorrosive processes. M2 diaphragm system is standard on Number 56 vacuum switches. (See notes 10 & 13.)
2. U7 designates a welded flush-type diaphragm. Available only in 1" NPT(M) 316SS on Numbers 5 & 6 pistons with K switching element. See page 15.
3. U8 designates the welded fire-safe diaphragm system. 316SS is stocked. Not available on Number 1 piston or vacuum switches. Example: U8-C2A is a 316SS fire-safe welded diaphragm system. See page 15.
4. U9 designates a welded diaphragm system. Not available on vacuum switches. Example: U9-A1A is a Monel welded diaphragm system. See page 15.
5. Other diaphragm and o-ring combinations may be available. Consult the factory or the SOR representative in your area for more information.
6. Wetted parts have been selected as representing the most suitable commercially available material for use in the service intended. However, they do not constitute a guarantee against corrosion or permeation, since processes vary from plant to plant and concentration of harmful fluids, gases or solids vary from time to time in a given process. Empirical experience by users should be the final guide. Alternate materials are generally available.

(Continued on page 13.)

O-Ring (Wetted)	Diaphragm (Wetted Primary)	Designator
Viton	Monel	A4
Kalrez		A6
Viton	Hastelloy-B	H4
Kalrez		H6
Viton	Hastelloy-C	J4
Kalrez		J6
Viton	Carpenter-20	L4
Kalrez		L6
Viton GLT	316L SS	M1
Buna-N		M2
Viton		M4
Neoprene		M5
Kalrez		M7
Aflas		M8
EPR		M9 (See Note 11)
Viton		N1 (See Note 13)
Buna-N		N3 (See Note 7)
Buna-N	N4 (See Notes 1, 13)	
Kalrez	N5 (See Note 13)	
Kalrez	Kalrez	N6
EPR	TCP Teflon-Coated Polyimide	N7 (See Note 13)
Aflas		N8 (See Note 13)
Buna-N	Buna-N	P1 (See Note 13)
Neoprene	Neoprene	R1
Viton	Viton	S1
Viton GLT		S2
Buna-N	Tantalum (See Note 10)	W2
Viton		W4
Neoprene		W5
Kalrez		W6
EPR	EPR	Y1
None	Welded	U7 (See Note 2)
None	Fire-Safe Welded	U8 (See Note 3)
None	Welded	U9 (See Note 4)

7. N3 diaphragm system utilizes a durable back-up diaphragm for high cycle-rate, high shock applications where Buna-N and TCP are compatible with the process. Consult factory if process temperatures are well below freezing.
8. This table shows allowable minimum and maximum temperatures for o-rings. Consult the factory for temperatures down to -65°F on fire-safe and welded metal diaphragm systems.

O-Ring Material	°F	°C
Viton	32 to 400	0 to 204
Viton GLT	-20 to 400	-29 to 204
Kalrez	0 to 400	-18 to 204
Aflas	25 to 400	-4 to 204
Buna-N Neoprene EPR	-30 to 200	-34 to 93
Fire-Safe/Welded Diaphragm System	-30 to 400	-34 to 204
TCP-Teflon Coated Polyimide Diaphragm	-30 to 400	-34 to 204

9. Dead bands are slightly higher when using H, J, N3, N6, U or W series diaphragm options. Consult the factory.
10. Diaphragm systems N1, N3, N4, N5, N6, N7, N8, P1, R1, S1, S2, W2, W4, W5, W6, Y1, U8, U9 are not available on Number 56 vacuum switches.
11. M9 diaphragm system is suggested for steam applications up to 400°F.
12. If Kalrez, EPR or Viton is selected for high temperature process media or ambient temperature requirements, the A, B, E, J, W or Y switching elements are suggested with reference to the table in Note 3, page 11.
13. Only diaphragm systems N1, N4, N5, N7, N8 and P1 are available on the 12-66 piston-spring combination.

Pressure and Vacuum Switches

Step 5: Pressure Port

6NN-K5-M4-C2A-YY

Piston	12, 4, 52, 54	6, 5, 9, 1, 56	12, 4, 52, 54	6, 5, 9, 1, 56	6, 5, 9, 1, 56	4, 54, 5*, 6*	12, 52	12, 52
Process Connection Size	1/4" NPT(F)		1/2" NPT(F)		3/4" NPT(M)	1" NPT(M)	1" NPT(F)	2" NPT(F) 1/4" NPT(F) Flushing Port
Pressure Port Material	Aluminum Series 2000 Wrought 356 or 360 Casting	B1A (Standard)	-	B2A	-	-	-	-
	Carbon Steel Ledloy Wrought WCB Casting	-	F1A (Standard)	-	F2A	F3A	-	-
	316 Stainless Steel Wrought CF-8M Casting	C1A		C2A		C3A	C4A	C5A C6A
	347 Stainless Steel Wrought CF-8C Casting	E1A		E2A		E3A	Consult factory for availability of Pressure Port Material and Process Connection size.	
	Carpenter 20 Stainless Steel Wrought CF-7M Casting	L1A		L2A		L3A		
	316L Stainless Steel Low Carbon	-	Z1A	-	Z2A	-		
	Brass ⁶ Half Hard Yellow Wrought Silicon Brass Casting	D1A		D2A		D3A		
	Hastelloy B	H1A		H2A		H3A		
	Hastelloy C	J1A		J2A		J3A		
	Monel	A1A		A2A		A3A		

*C4A only available with Pistons 5 & 6 when U7 diaphragm is specified. See page 15.

Notes

- Select designators for material and connection size. Large bold-face letters denote those items generally available from stock. Small light-face letters denote items with limited stock and possible long delivery.
- 1/4" and 1/2" tapered BSP(F) pressure ports are available. Consult factory.
- Combinations are possible when a particular connection size is not available for the range (piston/spring) desired. For example, if 2" NPT(F) is desired for a Number 4 piston, the Number 12 pressure port can be supplied. The piston would be designated as Number 124 and the overrange and proof pressures for Number 12 apply. Note: 124, 125 and 126 are the only available combinations.
- Many other materials such as PVC, Kynar, etc., are available. Denote materials not shown by specifying an X followed by the required connection size, and describe the material.

Examples:

- X2A = PVC pressure port with 1/2" NPT(F) connection.
X1A = Titanium pressure port with 1/4" NPT(F) connection.
Non-metal pressure ports generally reduce proof pressure and may reduce overrange pressure. The pressure port material may limit the process temperature. Delivery may be longer than normal.
- Raised-face and flat-face flanges to match ASA 150 and ASA 300 lb. in commercially available materials can be supplied on Series 12 and 4 pistons by adding an X suffix to the model numbers and specifying "X - (size) inch (material) (raised- or flat-) face flange to match ASA (rating) lb."
 - Brass not available on Piston Numbers 9 and 1.
 - 1/4" NPT(F) Flushing Port standard on C6A pressure ports.

See next page for presentation of welded diaphragm and FM Approved fire-safe systems.

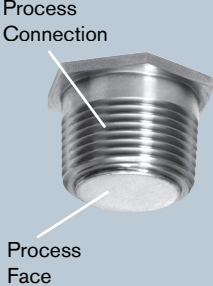
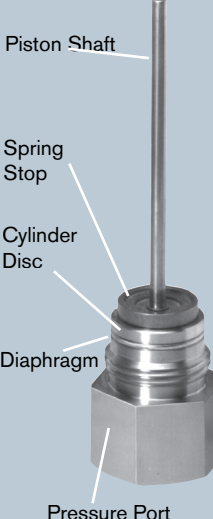
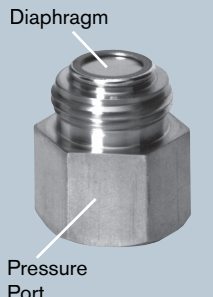
Designator	Description
<p>U7</p> 	<p>Welded Flush-Type Diaphragm System</p> <p>A metal diaphragm is welded to the process face of the pressure port, thereby, eliminating the o-ring. This arrangement may be indicated for viscous or slurry process where cleanliness is required or where process build-up and clogging is unacceptable.</p> <p>The pressure port designator determines the material: Only 1" NPT(M) 316SS is available.</p> <p>Example: U7-C4A U7 = 316SS welded flush-type diaphragm C4A = 1" NPT(M) 316SS pressure port</p> <p>Note: U7 is limited to Numbers 5 and 6 pistons and the K switching element. Not available on vacuum switches.</p>
<p>U8</p> 	<p>Fire-Safe Welded Diaphragm System</p> <p>Factory Mutual System Approved - U.S Patent Number 4,438,305</p> <p>Tested in flames at 1900°F for periods up to 30 minutes while pressurized to the rated overrange pressure.</p> <p>A metal diaphragm, the cylinder disc and the pressure port are welded as a unit, thereby, eliminating the o-ring. This arrangement may be indicated for extremely corrosive, hot, harsh or volatile process where o-rings are not suitable. See fire-safe definition on page 6.</p> <p>316SS is stocked. Hastelloy B and C, Monel and Titanium are available, but may require a longer lead time. The pressure port designator determines the material.</p> <p>Example: U8-C2A U8 = Fire-safe welded diaphragm system C2A = 1/2" NPT(F) 316SS pressure port</p> <p>Note: 1/2" NPT(F) is stocked; 1/4" NPT(F) is not stocked and has a longer lead time. Not available on Number 1 piston and vacuum switches.</p>
<p>U9</p> 	<p>Welded Diaphragm System</p> <p>A metal diaphragm is welded to the pressure port, thereby, eliminating the o-ring. This arrangement may be indicated for extremely corrosive, hot or harsh process where o-rings are not suitable.</p> <p>316SS is stocked. Hastelloy B and C, Monel and Titanium are available, but may require a longer lead time. The pressure port designator determines the material.</p> <p>Example: U9 - A2A U9 = Monel welded diaphragm A2A = 1/2" NPT(F) Monel pressure port</p> <p>Note: Not available on vacuum switches.</p>

C6A Two-inch Pressure Port

The wide pressure port minimizes the possibility of clogging when the process media is sludgy or viscous. See page 20 for dimensions. A 2" NPT(F) pressure port with a 1/4" NPT(F) flushing port can be supplied with a welded diaphragm, or with a conventional diaphragm and o-ring combination.

Pressure and Vacuum Switches

Step 6: Accessories

6NN-K5-M4-C2A-YY

Accessory / Option & Description		Designator
Wetted parts are cleaned for industrial oxygen service.		BB
ATEX Certified pressure/vacuum switch. Available with B3, B4, B5 and B6 housings. See Agency Listings on page 18 for details.		CL
CSA Certified pressure/vacuum switch. Available with PP, NN, RB, RN, RT, B3 and B6. Housing has earth (ground) lug. See Agency Listing on page 17 & 18 for details.		CS
Neoprene cover gasket (o-ring) to make L, S and TA explosion-proof housings weathertight.		CG
Cemented cover gasket on weathertight housings.		GC
Sealed electrical lead adapter. Provides protection to housing interior, switching element and dry side of pressure sensing assembly from condensate in the electrical conduit and corrosive atmospheres. (Protrudes approximately 2" from housing.)		GG
Universal terminal box. Stainless steel, 1/2" NPT(F). ATEX Approved EEx d IIC T4, T5, T6		HB
Universal terminal box. Stainless steel, M20x1.5(F). ATEX Approved EEx d IIC T4, T5, T6		HBME
Universal terminal box. Stainless steel, 1/2" NPT(F), FM Approved and CSA Certified. Explosion proof Class I, Groups A, B, C, D; Class II, Groups E, F, G; Class III; Divisions 1 & 2(NEMA 4X, IP65)		HT
Breather Drain	Crouse Hinds ECD-15 for Hazardous Locations Class I, Groups C & D; Class II, Groups E, F and G; on S or SC housings only.	KK
	Sintered metal plug in weathertight housing.	
Terminal block. 6-place compression type standard in B and R series housings. Optional in LC and SC housings. 6-place screw type standard in J4 housing.		LL
Universal terminal box, "HB" with M20 xl.5. 316SS. Explosion proof. ATEX Approved.		ME
Vacuum protector plate. Retains diaphragm in pressure switch if subjected to vacuum greater than 15 in. Hg. Material matches or exceeds pressure port material. N/A on Pistons 52, 54, or 56.		MM
Compliance to NACE Certification MR0175.		NC
Carbon steel body with stainless steel adjusting nut.		PB
Pipe (stanchion) mounting kit for (1-1/2" to 2" pipe).		PK
Tag, fiber. Attached with plastic wire to housing. Stamped with customer specified tagging information.		PP
Tag, stainless steel. Attached with stainless steel wire to housing. Stamped with customer specified tagging information. (2 lines, 18 characters and spaces per line.)		RR
Stainless steel body and adjusting nut for corrosive environments.		SB
Stainless steel piston and cylinder disc for corrosion resistance.		SP
Explosion proof and weathertight electrical junction box with screw terminals. 3/4" NPT(F) top or right conduit connections as required. UL Listed and CSA Certified Class I, Groups A, B, C, D; Class II, Group E, F & G; Division 1 & 2. (L, LC, S, SC and TA housing.) Includes cover o-ring for weathertight applications.		TB
Oversize stainless steel nameplate or separate stainless steel tag. Permanently attached to housing. Stamped with customer specified tagging information.		TT
Fungicidal varnish. Covers exterior and interior except working parts.		VV
UL Listed pressure/vacuum switch. Available with B3 and B6 housings. See Agency Listings on page 17 & 18 for details.		WV
Epoxy coating. Exterior only. Polyamide epoxy with 316SS pigment.		YY
Chained cover with captive screws to conform to former JIC specification.		ZZ
"X" is used as a suffix to the model number for special requirements not keyed elsewhere in the model number by an "X". Each "X" must be completely identified in the text of the order or inquiry. When more than one "X" is required, use "X" followed by the number of such items. For example, "X3" means three separate otherwise unidentifiable requirements.		X
<p>Note: See pages 17 & 18 for Agency Approved, Certified or Listed Accessories/Options.</p> <p>Representative Information Only: A slash and a three-digit number (/000) appearing after the last Accessory designator letter in the model number denotes special administrative procedures with respect to factory representatives. It is not part of the model number and is used only by the factory or a factory representative.</p>		

Pressure and Vacuum Switches

Agency Listings

UL For Hazardous Locations Class I, Groups B, C, D; Class II, Groups E, F, G; Division 1 & 2

Piston	Spring	Housing	Switching Element	Diaphragm & O-Ring	Pressure Port Material and Connection Size	Accessories
1, 4, 5, 6, 9, 12, 45, 46, 52, 54, 56, 124, 125, 126	2, 3, 4, 5, 45, 66, 116, 117, 118, 216, 316, 614	B3, B6, B8	A, AA, B, BB, C, E, EE, G, GG, GA, H, J, JJ, JL, K, KK, KA, L, LL, N, S, T, W, Y, YY	A1, A4, A6, H4, H6, J4, J6, L4, L6, M1, M2, M3, M4, M5, M6, M7, M8, M9, N1, N2, N3, N4, N5, N6, N7, N8, P1, R1, S1, S2, W2, W3, W4, W5, W6, Y1, U8, U9	All	WV Required
			Maximum: 15A @ 300 VAC 10A @ 125 VDC			MM, PB, PC, PK, PP, RR, TT, VV, YY, SA, SB, X

CSA For Hazardous Locations Class I, Groups B, C, D; Class II, Groups E, F, G; Division 1 & 2

Piston	Spring	Housing	Switching Element	Diaphragm & O-Ring	Pressure Port Material and Connection Size	Accessories
1, 4, 5, 6, 9, 12, 45, 46, 52, 54, 56, 124, 125, 126	2, 3, 4, 5, 45, 66, 116, 117, 118, 216, 316, 614	B3, B6, B8	A, AA, B, BB, C, E, EE, G, GG, GA, H, J, JJ, JL, K, KK, KA, L, LL, N, S, T, W, Y, YY	All	All	CS Required
			Maximum: 15A @ 300 VAC 10A @ 125 VDC			All except LL, KK, ZZ

General Purpose and Weathertight (CSA Enclosure Type 4)

Piston	Spring	Housing	Switching Element	Diaphragm & O-Ring	Pressure Port Material and Connection Size	Accessories
1, 4, 5, 6, 9, 12, 45, 46, 52, 54, 56, 124, 125, 126	All	PP (General Purpose)	A, AA, B, BB, C, E, EE, G, GG, GA, H, J, JJ, JL, K, KK, KA, L, LL, N, S, T, W, Y, YY	All	All	CS Required
		NN (Type 4)	A, AA, AF, AG, B, BB, C, E, EE, EF, EG, G, GG, GA, H, J, JJ, JL, JF, JG, K, KK, KA, L, LL, N, S, T, W, Y, YY			All except GC, LL
		RN, RT (Type 4)	D, DA, M (Manual Reset only)			
		RB, RH (Type 4)				

JIS/RIIS For Hazardous Locations Rating: Explosion Proof Class IIBT4

Piston	Spring	Housing	Switching Element	Diaphragm & O-Ring	Pressure Port Material and Connection Size	Accessories
1, 4, 5, 6, 9, 12, 52, 54, 56	2, 3, 4, 5, 45, 66, 116, 117, 118, 216, 316, 614	J3, J4, J5, J6, J7, J8	A, AA, B, BB, C, E, EE, G, GG, GA, H, J, JJ, JL, K, KK, KA, L, LL, N, S, T, W, WW, Y, YY	All	Material: A, B, C, D, E, F, H, J, L	BB, MM, NN, PB, PC, PK, PP, RR, SB, TT, VV, YY, X
					Connection Size: 1, 2, 3, 4, 5, 6	
					Thread Type: A, B, J	

FM Pressure Supervisory Switches for Fuel Gas/Fuel Oil, and Ventilating or Combustion Air

Piston	Spring	Housing	Switching Element	Diaphragm & O-Ring	Pressure Port Material and Connection Size	Accessories
1, 4, 5, 6, 9, 12	2, 3, 4, 5, 45, 614	PP (NEMA 1)	CA	M2, M4, M5, N1, N3, N4, N5, N6, P1, R1, S1, U9, W2, W4, W5, W6, Y1	Material: A, B, C, D, E, F, H, J, L	KK (PP Housing only)
		NN N3 N4 (NEMA 4)			Connection Size: 1, 2, 3, 4, 5, 6	BB, MM, GG, PP, RR, SS, TT, VV, YY, ZZ
					Thread Type: A, B	

Airflow Interlocking Switches for Ventilating or Combustion Air

Piston	Spring	Housing	Switching Element	Diaphragm & O-Ring	Pressure Port Material and Connection Size	Accessories
4, 12	66 (N Switch)	PF (NEMA 1)	N (12 Piston only)	P1	B1A, B2A	PP, RR, SS (SS same as TT)
	2, 4, 5, 45, 614		C, EE, G, K, L, S, T, W			

ATEX BASEEFA Electrical Equipment for Flammable Atmospheres Rating: EEx d IIC T6 per EN 50-014 & 018 BAS Certification Number Baseefa02ATEX0252

Piston	Spring	Housing	Switching Element	Diaphragm & O-Ring	Pressure Port Material and Connection Size	Accessories
1, 4, 5, 6, 9, 12, 45, 46, 52, 54, 56, 124, 125, 126	2, 3, 4, 5, 45, 66, 116, 117, 118, 216, 316, 614	B3, B4, B5, B6, B7, B8	A, AA, AF, AG, B, BB, C, E, EE, EF, EG, G, GG, GA, J, JJ, JF, JG, JL, K, KA, KK, L, LL, N, S, T, W, Y, YY	All	All	CL Required All except CS, GG, KK, LL, WV, ZZ

Pressure and Vacuum Switches

Manual Reset

Manual Reset Button

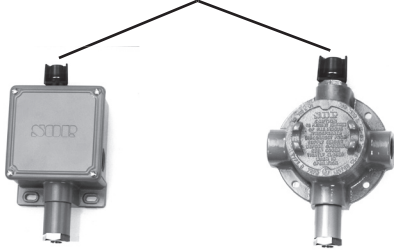

RB - Weathertight S - Explosion Proof

SOR Pressure Switches in this catalog may be specified with manual reset electrical switching elements D or M. D actuates automatically on increasing pressure. M actuates automatically on decreasing pressure. Depress the button to manually reset. Housings must be RB (weathertight) or S (explosion proof) because of the requirement of a hub for the manual reset assembly. Refer to page 3 for How to Order instructions.

Shipping Weights

Housing	Weight (lbs)	(kgs)
H3	1.5	0.75
NN, N3, N4, PF, PP, P3	2	1
RB, RM, RN	2.5	1.25
N6	3	1.5
LC, SC	4	2
L, S	5	2.5
TA	6	3
B3, B4, J4, RT, RS	8	4
B5, B6	10	5

Actual shipping weights may vary from the charted values because of product material, configuration and packaging requirements.

Note

PK Pipe Kit adds approximately 1.5 lbs (0.7 kgs). TB Junction box adds approximately 5 lbs (2.25 kgs).

Dimensions

Dimensions in this catalog are for reference only. They may be changed without notice. Contact the factory for certified drawings for a particular model number.

- Notes:**
1. Dimensions in this catalog are expressed as millimeters over inches (Linear = mm/in.).
 2. Dimensions marked with an asterisk (*) on housing dimension drawings (pages 20 through 31) vary with respect to process connection size. The chart below lists these dimension variances.
 3. Electrical Connection Size: 3/4" NPT(F) standard. 1/2" NPT(F), 1/2" NPT(M), M20 x 1.5, PG 13.5, PF 3/4" optional. Consult the factory for compatibility with selected housing or agency listing.

Process Connection Size	Piston Number		
	12, 52	4, 54	6, 5, 9, 1, 56
1/4" NPT(F)	Shown	Shown	Shown
1/2" NPT(F)	Shown	Shown	Add <u>13.2</u> 0.52
3/4" NPT(M)	-	-	Add <u>23.1</u> 0.91
1" NPT(F)	Add <u>5.6</u> 0.22	-	-
1" NPT(M)	-	Add <u>46.0</u> 1.81	-
2" NPT(F)	Add <u>25.4</u> 1.00	-	-
Length "A" 1/4" NPT(M)	Add <u>29.7</u> 1.17	Add <u>29.7</u> 1.17	Add <u>29.7</u> 1.17
Length "A" 1/2" NPT(M)	Add <u>38.9</u> 1.53	Add <u>38.9</u> 1.53	Add <u>38.9</u> 1.53

Pressure and Vacuum Switches

Dimensions

Dimensions in this catalog are for reference only. They may be changed without notice. Contact the factory for certified drawings for a particular model number.

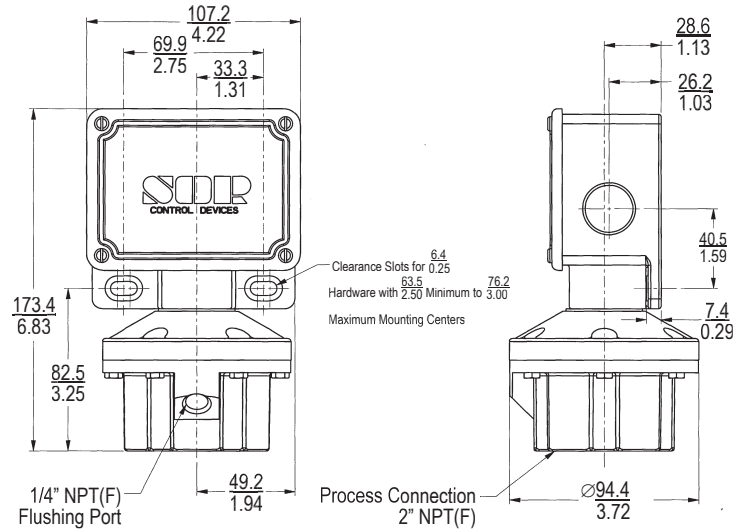

Drawing # 0091354

Wide Pressure Port: C6A

See description on page 15.

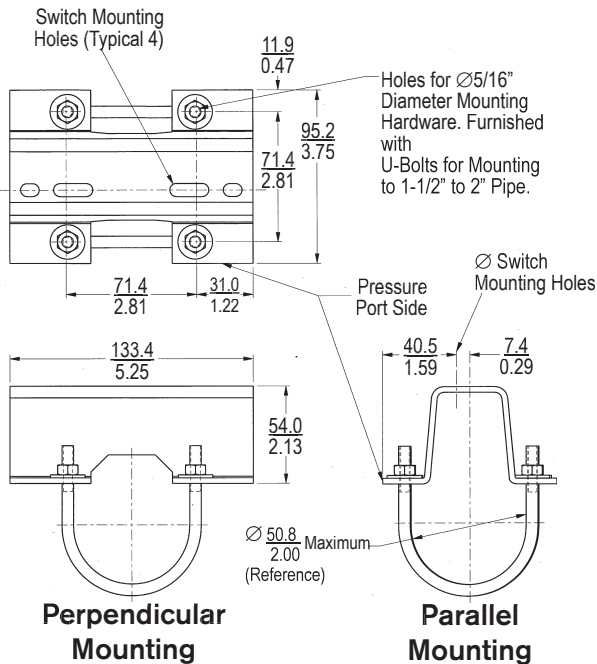

Drawing # 0090300

Pipe Mounting Kit: PK

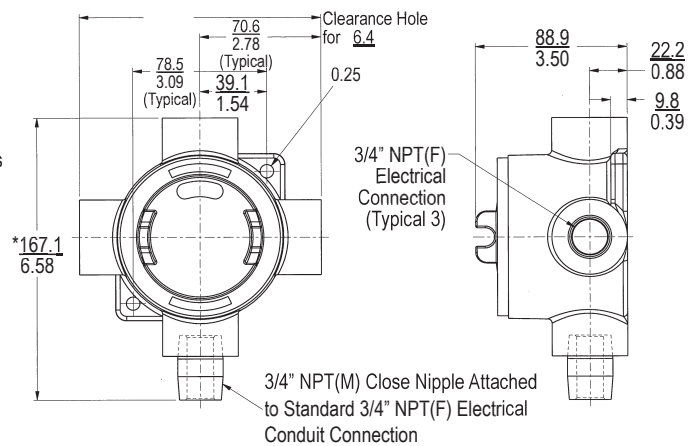

Drawing # 0091353

Junction Box with Terminal Block: TB

Dimensions in this catalog are for reference only. They may be changed without notice. Contact the factory for certified drawings for a particular model number.

Weathertight - NEMA 4, 4X, IP65

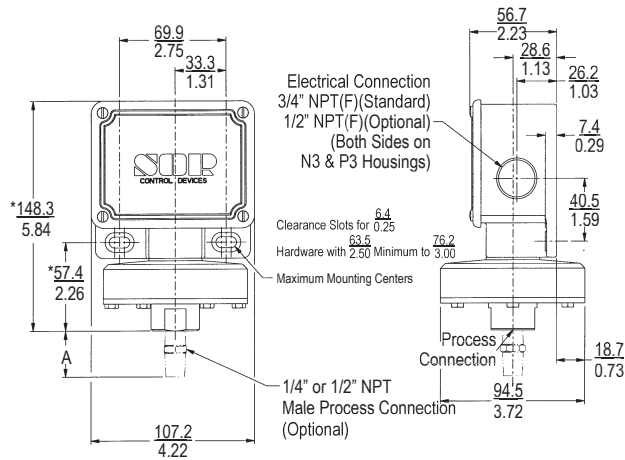

Drawing # 0090100

Designators: **NN, N3, N4, PP, PF, P3**
Piston Numbers **12, 52**

Housings PP, P3 and PF are General Purpose.
(Cover gasket is not installed.)

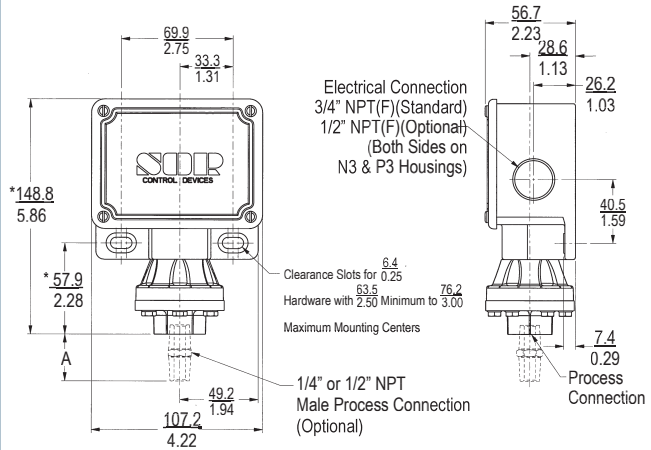

Drawing # 0090110

Designators: **NN, N3, N4, PP, PF, P3**
Piston Numbers **4, 54**

Housings PP, P3 and PF are General Purpose.
(Cover gasket is not installed.)

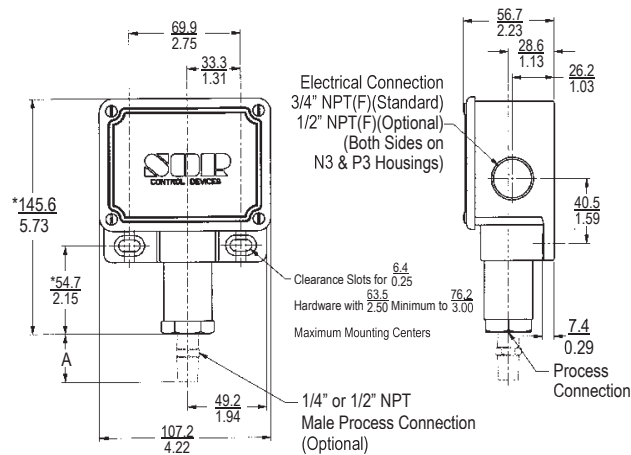

Drawing # 0090120

Designators: **NN, N3, N4, PP, PF, P3**
Piston Numbers **5, 6, 1, 9, 56**

Housing PP, P3 and PF are General Purpose.
(Cover gasket is not installed.)

*Refer to Dimensions table on page 19 for changes in length due to process connection size, including A dimension.

Pressure and Vacuum Switches

Dimensions

Dimensions in this catalog are for reference only. They may be changed without notice. Contact the factory for certified drawings for a particular model number.

Weathertight - NEMA 4, 4X, IP65

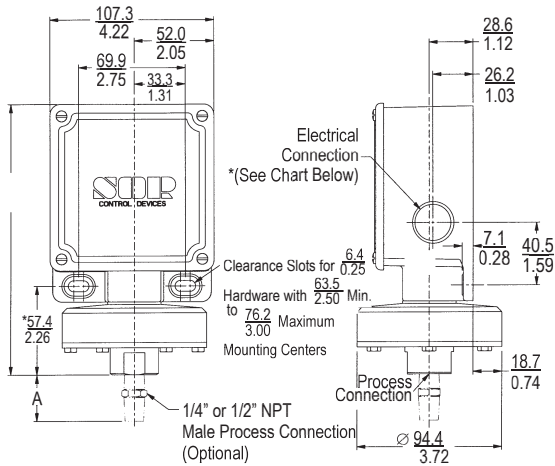

Housing	Electrical Connection
RN, RT	3/4" NPT(F)
RM, RS	M20 x 1.5

Drawing # 0090247

Designators: **RM, RN, RS, RT**
Piston Numbers **12, 52**

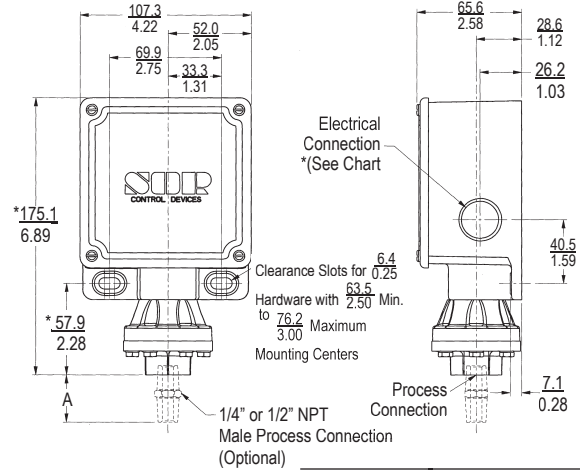

Housing	Electrical Connection
RN, RT	3/4" NPT(F)
RM, RS	M20 x 1.5

Drawing # 0090246

Designators: **RM, RN, RS, RT**
Piston Numbers **4, 54**

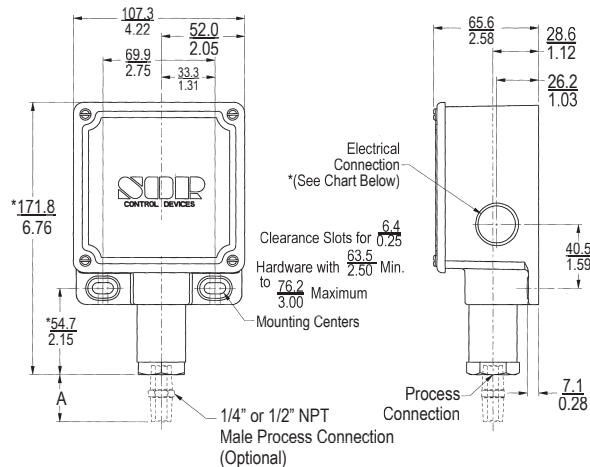

Housing	Electrical Connection
RN, RT	3/4" NPT(F)
RM, RS	M20 x 1.5

Drawing # 0090245

Designators: **RM, RN, RS, RT**
Piston Numbers **5, 6, 1, 9, 56**

*Refer to Dimensions table on page 19 for changes in length due to process connection size, including A dimension.

Pressure and Vacuum Switches

Dimensions

Dimensions in this catalog are for reference only. They may be changed without notice. Contact the factory for certified drawings for a particular model number.

Open Bracket

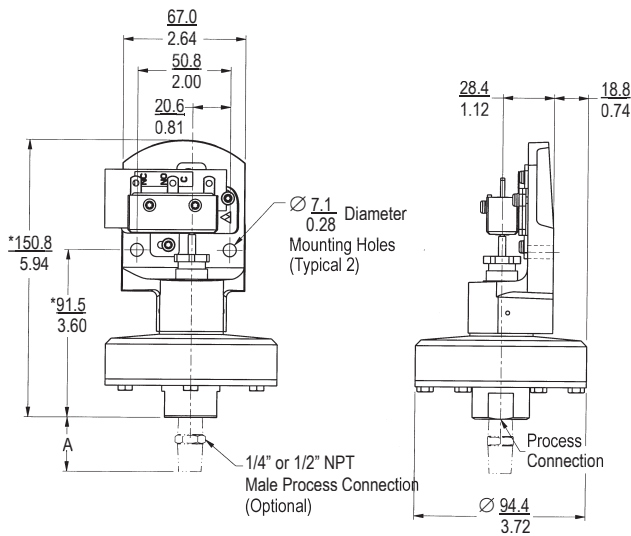

Drawing # 0090007

Designators: H3

Piston Numbers 12, 52

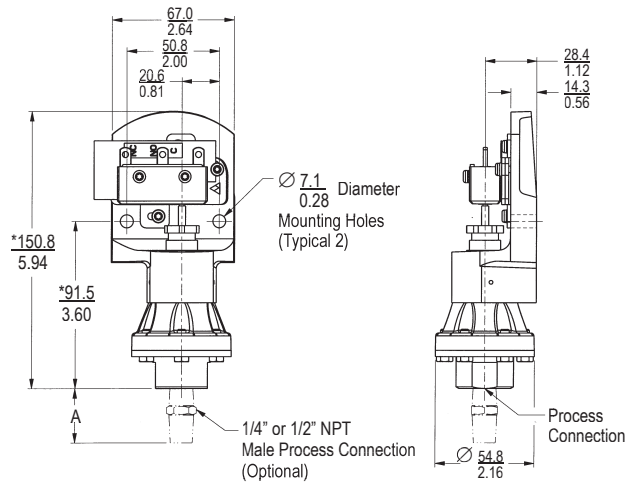

Drawing # 0090017

Designators: H3

Piston Numbers 4, 54

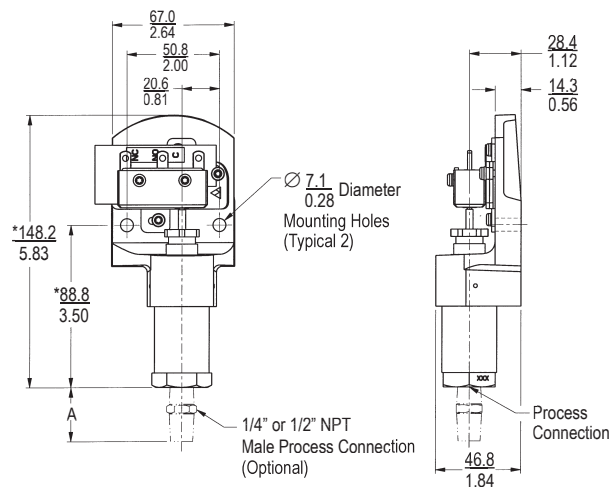

Drawing # 0090027

Designators: H3

Piston Numbers 5, 6, 9, 1, 56

*Refer to Dimensions table on page 19 for changes in length due to process connection size, including A dimension.

Dimensions in this catalog are for reference only. They may be changed without notice. Contact the factory for certified drawings for a particular model number.

Weathertight - NEMA 4, 4X, IP65

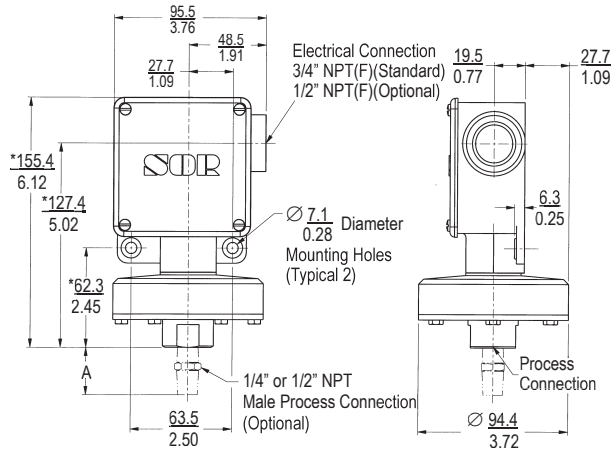

Drawing # 0090009

Designators: **N6**

Piston Numbers **12, 52**

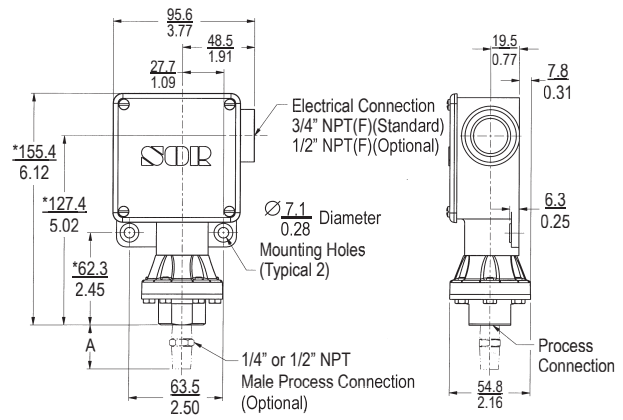

Drawing # 0090010

Designators: **N6**

Piston Numbers **4, 54**

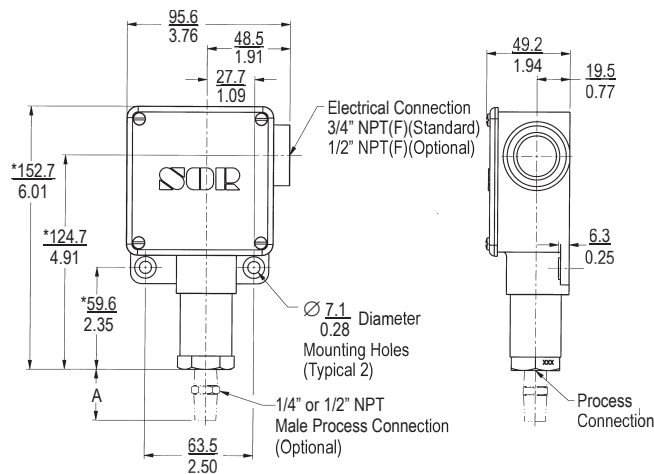

Drawing # 0090020

Designators: **N6**

Piston Numbers **5, 6, 9, 1, 56**

*Refer to Dimensions table on page 19 for changes in length due to process connection size, including A dimension.

Dimensions in this catalog are for reference only. They may be changed without notice. Contact the factory for certified drawings for a particular model number.

Conventional Explosion Proof

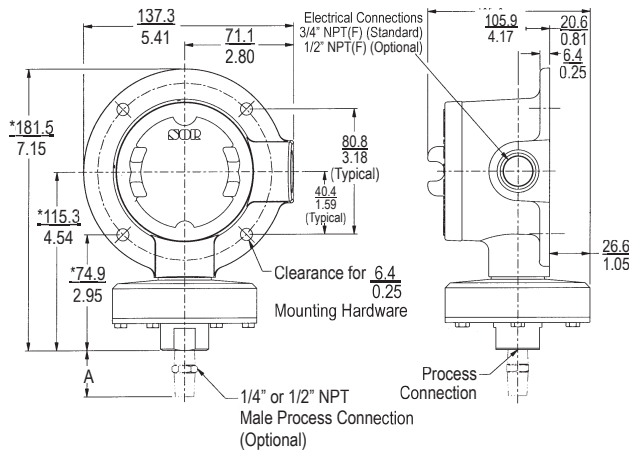

Drawing # 0090146

Designators: **L**

Piston Numbers **12, 52**

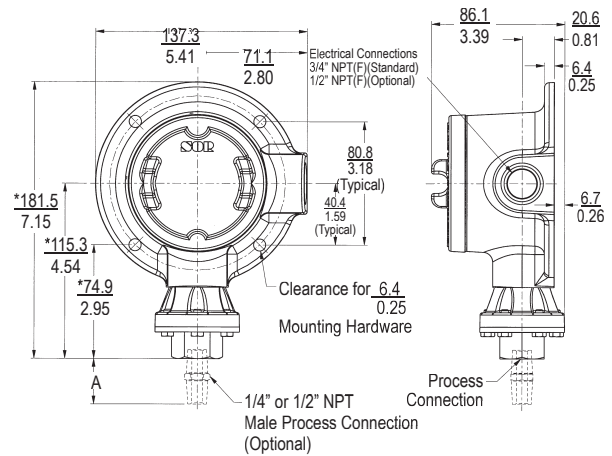

Drawing # 0090145

Designators: **L**

Piston Numbers **4, 54**

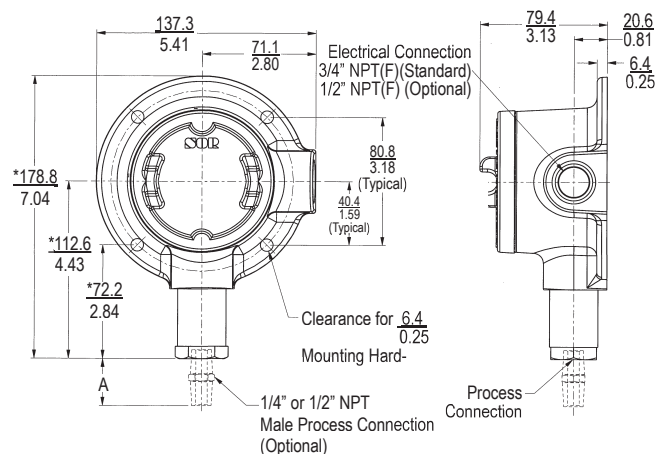

Drawing # 0090144

Designators: **L**

Piston Numbers **5, 6, 9, 1, 56**

*Refer to Dimensions table on page 19 for changes in length due to process connection size, including A dimension.

Dimensions in this catalog are for reference only. They may be changed without notice. Contact the factory for certified drawings for a particular model number.

Conventional Explosion Proof

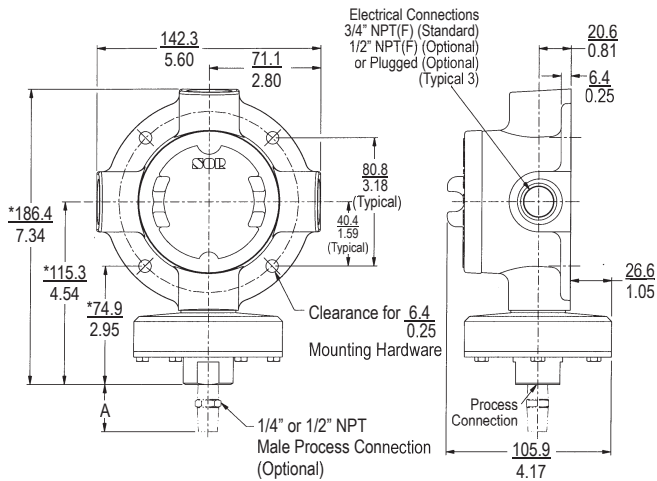

Drawing # 0090149

Designators: **S**
Piston Numbers **12, 52**

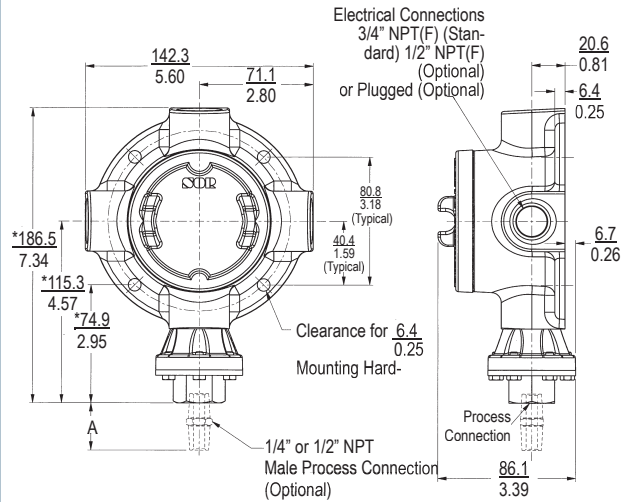

Drawing # 0090148

Designators: **S**
Piston Numbers **4, 54**

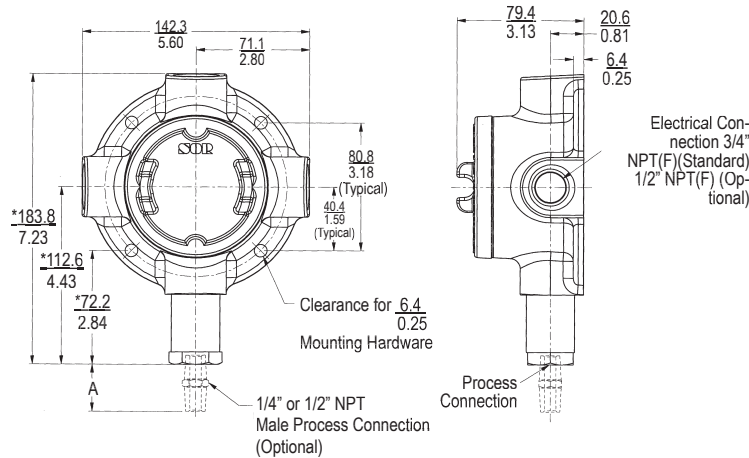

Drawing # 0090147

Designators: **S**
Piston Numbers **5, 6, 9, 1, 56**

*Refer to Dimensions table on page 19 for changes in length due to process connection size, including A dimension.

Dimensions in this catalog are for reference only. They may be changed without notice. Contact the factory for certified drawings for a particular model number.

Conventional Explosion Proof

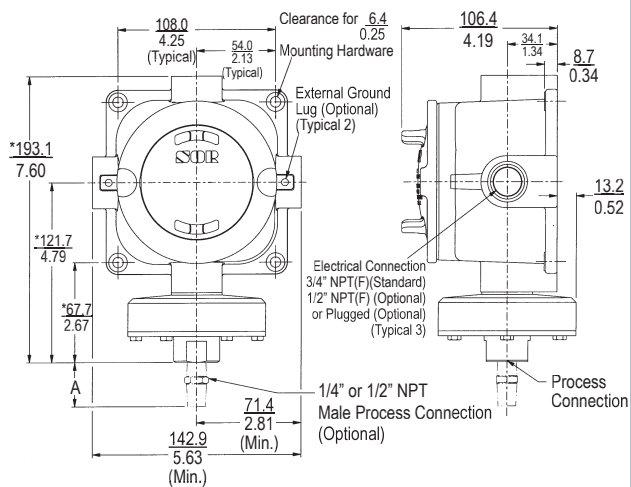

Drawing # 0090184

Designators: **LC, SC**

Piston Numbers **12, 52**

SC shown. LC identical except right-hand electrical connection only.

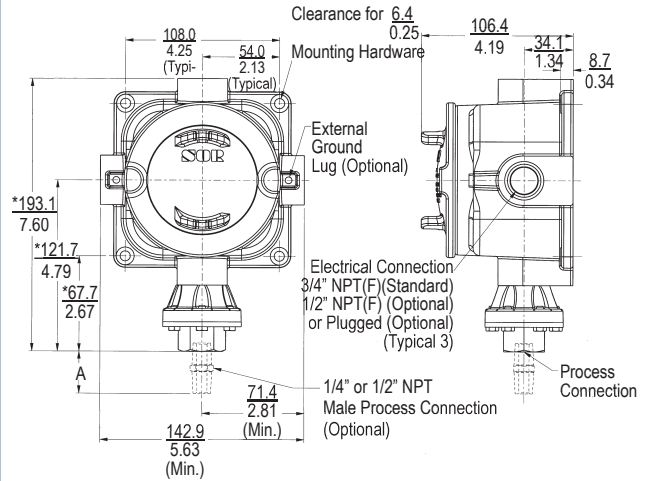

Drawing # 0090186

Designators: **LC, SC**

Piston Numbers **4, 54**

SC shown. LC identical except right-hand electrical connection only.

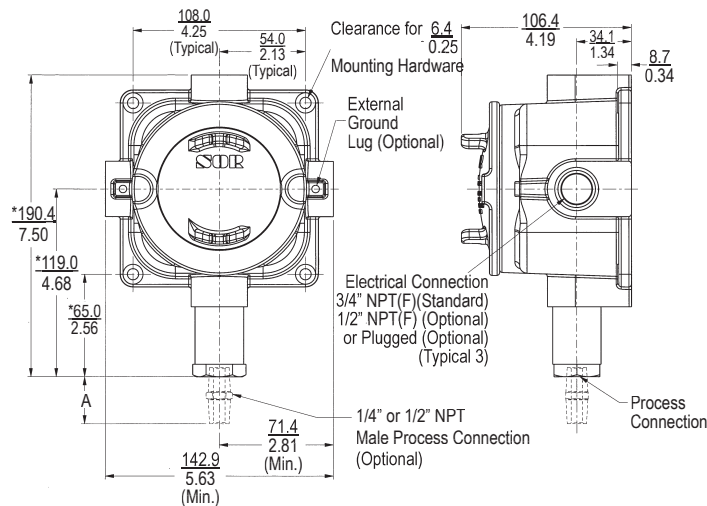

Drawing # 0090103

Designators: **LC, SC**

Piston Numbers **5, 6, 9, 1, 56**

SC shown. LC identical except right-hand electrical connection only.

*Refer to Dimensions table on page 19 for changes in length due to process connection size, including A dimension.

Dimensions in this catalog are for reference only. They may be changed without notice. Contact the factory for certified drawings for a particular model number.

Conventional Explosion Proof

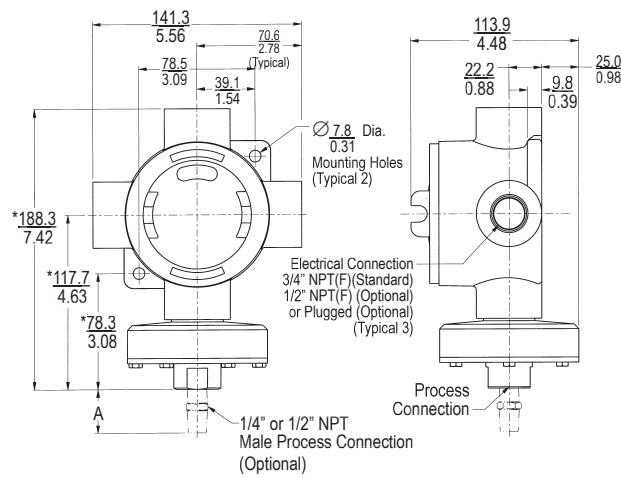

Drawing # 0090155

Designators: **TA**

Piston Numbers **12, 52**

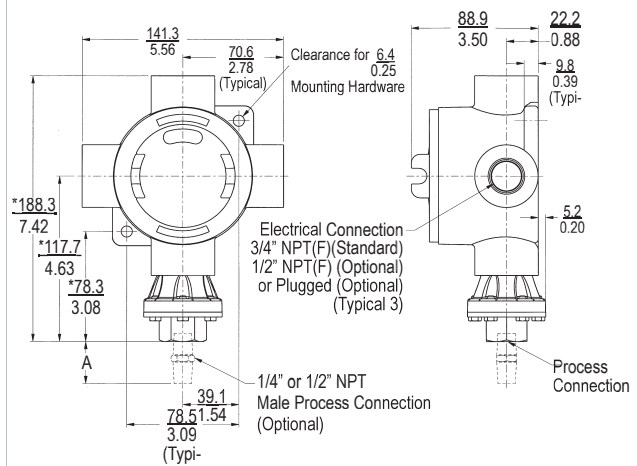

Drawing # 0090154

Designators: **TA**

Piston Numbers **4, 54**

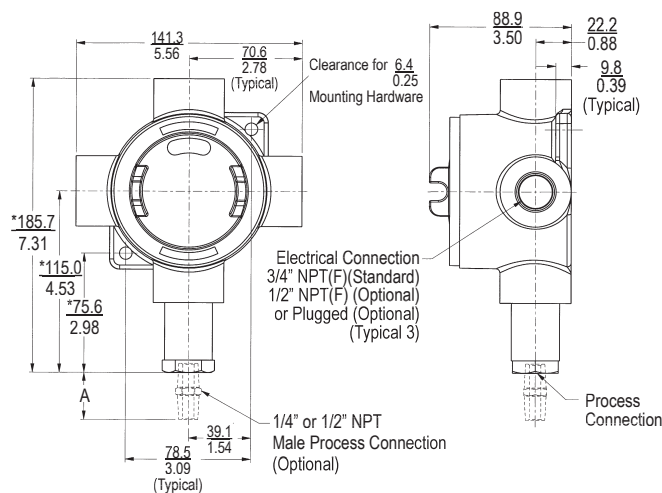

Drawing # 0090153

Designators: **TA**

Piston Numbers **5, 6, 9, 1, 56**

*Refer to Dimensions table on page 19 for changes in length due to process connection size, including A dimension.

Dimensions in this catalog are for reference only. They may be changed without notice. Contact the factory for certified drawings for a particular model number.

Explosion Proof

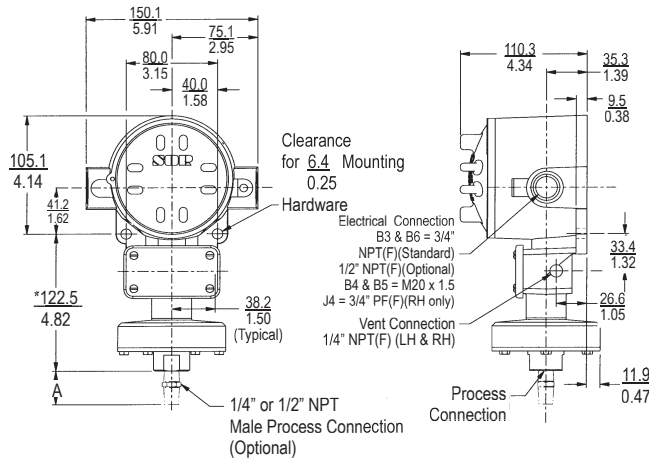

Drawing # 0090297

Designators: B3, B4, B5, B6, J4
Piston Numbers 12, 52

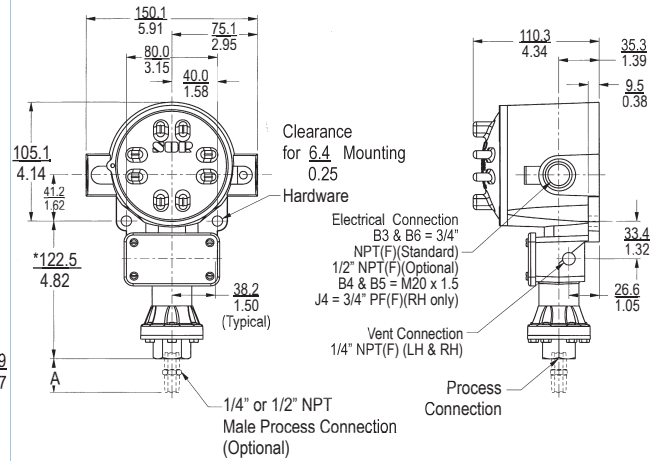

Drawing # 0090284

Designators: B3, B4, B5, B6, J4
Piston Numbers 4, 54

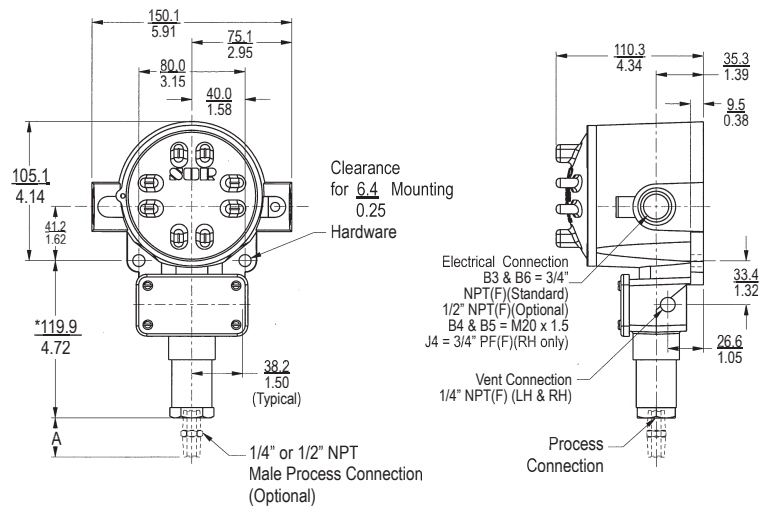

Drawing # 0090882

Designators: B3, B4, B5, B6, J4
Piston Numbers 5, 6, 9, 1, 56

*Refer to Dimensions table on page 19 for changes in length due to process connection size, including A dimension.

Dimensions in this catalog are for reference only. They may be changed without notice. Contact the factory for certified drawings for a particular model number.

Weathertight - NEMA 4, 4X, IP65

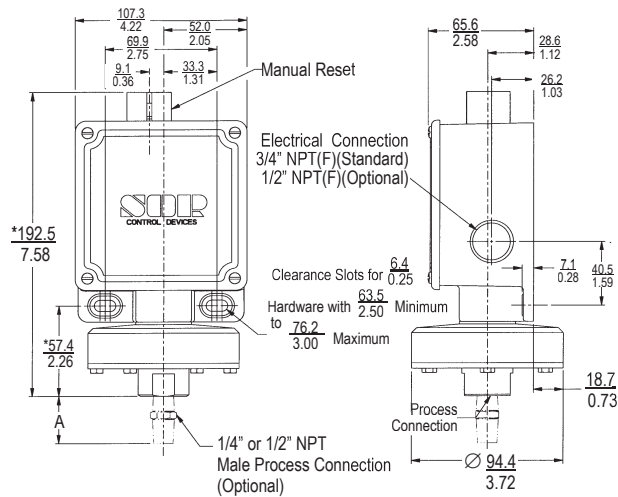

Drawing # 0090269

Designators: **RB Manual Reset**
Piston Numbers **12, 52**

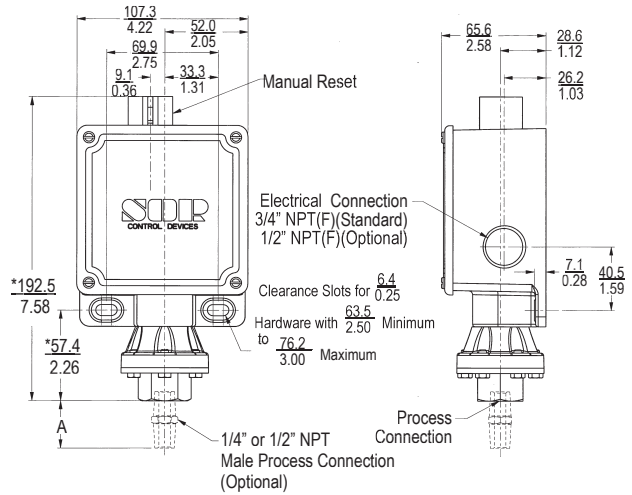

Drawing # 0090270

Designators: **RB Manual Reset**
Piston Numbers **4, 54**

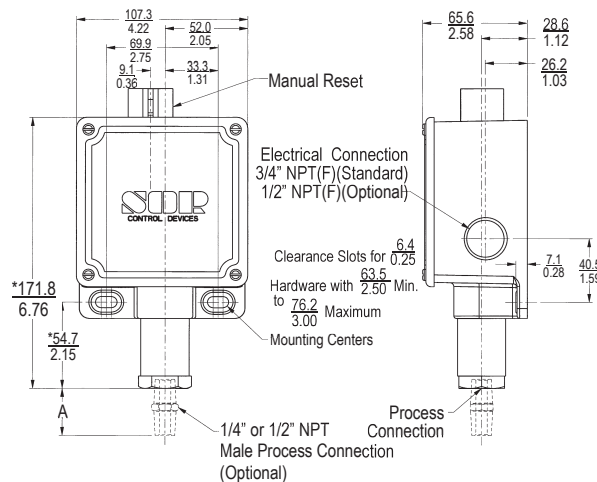

Drawing # 0090271

Designators: **RB Manual Reset**
Piston Numbers **5, 6, 1, 9, 56**

*Refer to Dimensions table on page 19 for changes in length due to process connection size, including A dimension.

Dimensions in this catalog are for reference only. They may be changed without notice. Contact the factory for certified drawings for a particular model number.

Conventional Explosion Proof

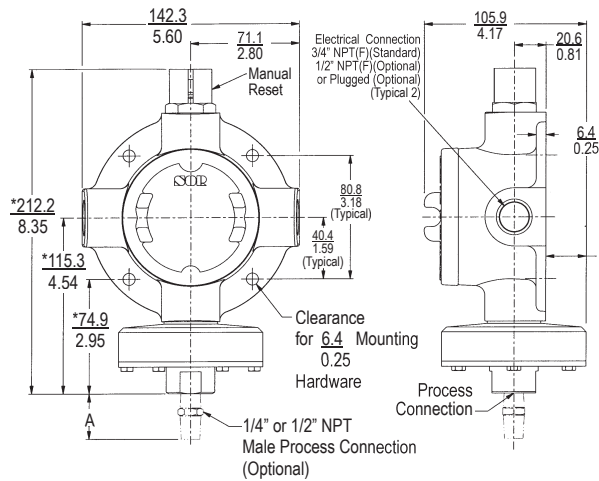

Drawing # 0090167

Designators: **S Manual Reset**
Piston Numbers **12, 52**

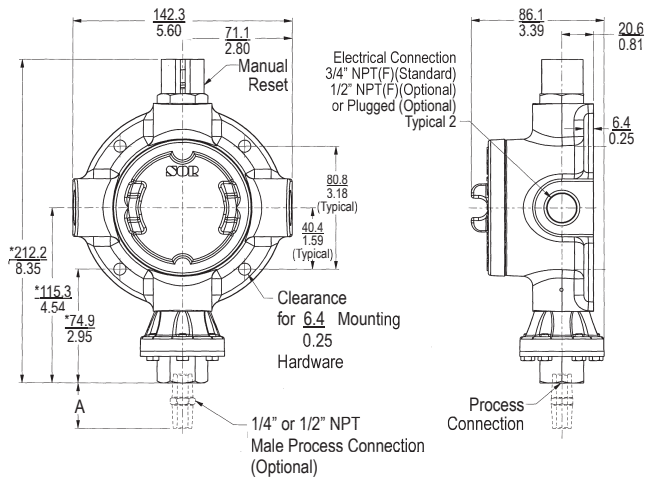

Drawing # 0090168

Designators: **S Manual Reset**
Piston Numbers **4, 54**

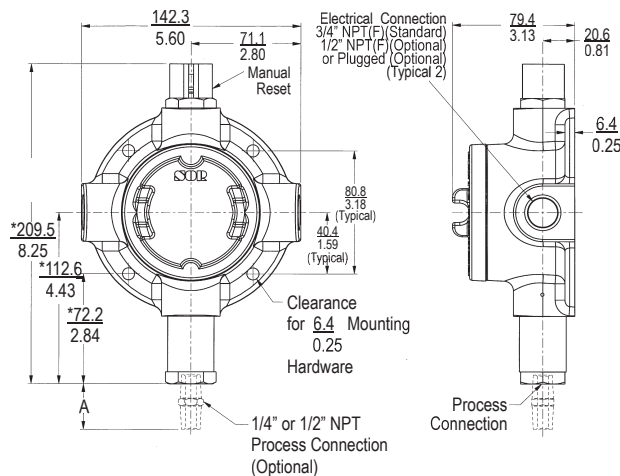

Drawing # 0090169

Designators: **S Manual Reset**
Piston Numbers **5, 6, 1, 9, 56**

*Refer to Dimensions table on page 19 for changes in length due to process connection size, including A dimension.



Process Instrumentation

SOR INC.

14685 West 105th Street
Lenexa, Kansas 66215

Phone 913-888-2630
Toll Free 800-676-6794
Fax 913-888-0767

www.sorinc.com

Registered Quality System to ISO 9001