



U.S. DEPARTMENT OF TRANSPORTATION
FEDERAL AVIATION ADMINISTRATION
National Policy

ORDER
8260.46D

08/20/2009

SUBJ: Departure Procedure (DP) Program

This order provides the policy, guidance, and standardization for initiating, developing, processing, and managing the Departure Procedure (DP) Program. The original order combined into a single product textual IFR departure procedures that were developed by the National Flight Procedures Office (NFPO) under the guidance of the Flight Standards Service (AFS), and graphical Standard Instrument Departures (SIDs) that were designed and produced under the direction of the Air Traffic Organization (ATO). The original order also provided for the graphic publication of complex IFR departure procedures to facilitate pilot understanding of the procedure as well as all area navigation (RNAV) DPs, both those developed solely for obstruction clearance and those developed for system enhancement. Also, the term Obstacle Departure Procedure (ODP) is introduced to describe certain procedures. This document defines two separate types of DPs: SIDs and ODPs.

Original Signed by
Chester D. Dalbey

John H. Allen
Director
Flight Standards Service

TABLE OF CONTENTS

Paragraph	Page
Chapter 1. General Information	
1-1. Purpose of This Order -----	1-1
1-2. Audience -----	1-1
1-3. Where Can You Find This Order -----	1-1
1-4. What This Order Cancels -----	1-1
1-5. Effective Date -----	1-1
1-6. Explanation of Changes -----	1-1
Chapter 2. Responsibilities	
2-1. Departure Procedure Guidelines -----	2-1
2-2. Responsibilities-----	2-9
2-3. Accuracy Verification and Responsibilities -----	2-14
2-4. Military Departure Procedures -----	2-14
2-5. FAA 8260-15 Series Forms-----	2-15
Appendix A. Guidelines for the Design of Graphic Instrument Departure Procedures (DPs) (Pages 1-10)	
Appendix B. Instructions for Completing Graphic Departure Procedure (DP) Requirements Worksheet (Pages 1-8)	
Appendix C. Instructions for Completing FAA Form 8260-2, Data Worksheet (Pages 1-4)	
Appendix D. Instructions for Completing FAA Form 8260-15A, Takeoff Minimums and Obstacle Departure Procedures (ODP) and Sample Forms (Pages 1-16)	
Instructions for Completing FAA Form 8260-15B, Graphic Departure Procedure (DP) [Non-RNAV Departure Procedures] and Sample Forms (Pages 17-28)	
Appendix E. Instructions for Completing FAA Form 8260-15B, Graphic Departure Procedures (DPs) [RNAV and RNP Departure Procedures] and Sample Forms (Pages 1-20)	
Instructions for Completing FAA Form 8260-15C, Departure (Data Record) and Sample Forms (Pages 21-32)	
Appendix F. Helicopter Departure Procedures (RESERVED)	

Paragraph

Page

Appendix G. Administrative Information

1.	Distribution-----	1
2.	Background-----	1
3.	Definitions-----	1
4.	Related Publications-----	4
5.	Forms and Reports -----	5
6.	Information Update-----	6

Chapter 1. General Information

1-1. Purpose of This Order. This order provides policy, guidance, and standardization for initiating, developing, processing, and managing the DP program.

1-2. Audience. The primary audience for this Order is **AeroNav Products**, who have the responsibility to develop instrument departure procedures. The secondary audience includes other Air Traffic Organization (ATO) Service Area offices and Flight Standards headquarters and regional office Divisions/Branches.

1-3. Where You Can Find This Order? Inspectors can access this order through the Flight Standards Information Management System (FSIMS) at <http://fsims.avs.faa.gov>. Operators may find this information on the Federal Aviation Administration's (FAA) Web site at http://www.faa.gov/library/manual/examiners_inspectors/8000.

1-4. What this Order Cancels. Order 8260.46C, Departure Procedure (DP) Program, dated August 5, 2005.

1-5. Effective Date.

1-6. Explanation of Changes.

a. General. Formatting revised to meet current Federal Aviation Agency (FAA) standards. Paragraphs are re-aligned for better editorial flow.

b. Paragraph 2-1a(1). Text added to clarify Terminal Instrument Procedures (TERPS) application of diverse departure criteria analysis.

c. Paragraph 2-1b. Paragraph revised and expanded to include all items unique to obstacle departure procedures (ODPs).

d. Paragraph 2-1b(1). Emphasizes the primary goal in ODP development.

e. Paragraph 2-1b(12). Deletes the requirement for mandatory VCOA development at high density airports where ATC will not allow the maneuver.

f. Table 2-1. VCOA note moved to paragraph 2-1b(11).

g. Paragraph 2-1c. Paragraph expanded to include all items unique to standard instrument departures (SIDs).

h. Paragraph 2-1c(2). Specifies that a Diverse Vector Area (DVA) must be established when ATC desires to use radar vectors to establish aircraft on published SIDs.

i. Paragraph 2-1d(2)(a). Adds requirement for supporting documentation when requesting Flight Standards approval for excessive climb gradients.

j. Paragraphs 2-1d(2)(b) and (c). Previously published notes now included as separate sub-paragraphs.

k. Paragraph 2-1d(3). Adds policy for DP speed restrictions.

l. Paragraph 2-1e(1). Provides guidance for charting minimum altitude restrictions (obstacle clearance and ATC) for both ODPs and SIDs.

m. Paragraph 2-1e(2). Provides guidance for charting required climb gradients (obstacle clearance and ATC) for both ODPs and SIDs.

n. Paragraph 2-1e(3). Provides guidance for charting speed restrictions (obstacle clearance and ATC) for both ODPs and SIDs.

o. Paragraph 2-1f(3). Adds DVA requirements for radar SIDs at runways that failed the TERPS diverse departure analysis.

p. Paragraph 2-1g(6). Adds guidance regarding use of the word “immediate/ immediately.”

q. Paragraph 2-2c(9). Requires the ATC facility providing departure control service to coordinate graphic DP name and computer code with the servicing ARTCC as specified in appendix A.

r. Paragraph 2-2g. NACO Responsibilities added.

s. Paragraph 2-3c. Requires notification of NACO for chart correction FDC NOTAMs.

t. Paragraph 2-5a(1)(e). Requires DVA information to be documented on Form 8260-15A.

u. Paragraph 2-5c. Requires supporting documentation when requesting Flight Standards approval.

v. Appendix A, paragraph 1j. Speed restriction policy re-located to paragraph.

w. Appendix A, table A-1 and paragraph 5b footnote ¹. Added VI leg type.

x. Appendix A, paragraph 5e. Replaced TYPE A/B designations with RNAV-1 and added RNP-1 DP guidance.

y. Appendix B. Changed “Block” to “Line” and minor editorial changes.

z. Appendix C. Changed “Block” to “Line” and minor editorial changes.

aa. Appendix D. Modifies Forms 8260-15A and 8260-15B and revises completion instructions accordingly. Also, deleted FAA Form 8260-15D, Departure Procedure (Continuation).

- bb.** Appendix D, section 1, paragraph 8a. Note added to provide guidance for AAO use.
- cc.** Appendix D, section 1, figures D-1 through D-5. Sample report format forms inserted.
- dd.** Appendix D, section 2, paragraph 6a. Note added to provide guidance for AAO use.
- ee.** Appendix E. Deleted FAA Form 8260-15D, Departure Procedure (Continuation). Modifies Form 8260-15B and revises completion instructions accordingly.
- ff.** Appendix E, section 1, paragraph 3b. Adds clarification that direction of turn is only required for DF legs when the course change exceeds 15 degrees.
- gg.** Appendix E, section 1, paragraph 3d and table E-1. VI leg capability added.
- hh.** Appendix E, section 1, paragraph 6. Note added to provide guidance for AAO use.
- ii.** Appendix E, section 2. Updated instructions to include VI legs.
- jj.** Appendix F. Prepared and Reserved Helicopter Departure Procedure to be established at a later time.
- kk.** Appendix G, paragraph 2. Functional area distribution codes and responsibilities are updated to reflect organizational changes.
- ll.** Appendix G, paragraph 3k. Diverse Vector Area definition added.
- mm.** Appendix G, paragraph 4kj. Added reference to Order 8260.53, Standard Instrument Departures that Use Radar Vectors to Join RNAV Routes.

THIS PAGE INTENTIONALLY LEFT BLANK

Chapter 2. Responsibilities

2-1. Departure Procedure (DP) Guidelines.

a. General. There are two types of DPs; those developed to assist pilots in obstruction avoidance, referred to as *Obstacle Departure Procedure (ODP)*, and those developed to communicate air traffic control clearances, referred to as *Standard Instrument Departure (SID)*.

(1) A diverse departure assessment must be conducted for those airports with approved instrument approach procedures. ODPs are developed by **AeroNav Products** at locations where they have instrument procedure development responsibility.

(2) ODPs may also be required at private airports where the FAA does not have instrument procedure development responsibility. It is the responsibility of non-FAA proponents to ensure a TERPS Diverse Departure obstacle assessment has been accomplished and an ODP developed, where applicable.

b. Obstacle Departure Procedures. An ODP and/or non-standard takeoff minimums must be developed when obstructions penetrate the 40:1 departure obstacle clearance surface (OCS) as described in Order 8260.3, Volume 4. Use table 1 as a guide to determine each situation and the required action. The following rules apply to ODPs:

(1) The primary goal in ODP development is to retain standard takeoff minimums with standard climb gradient to the extent possible. See table 1 for recommended ODP development combinations.

(2) Establish only one ODP for a Runway. This will be considered the default IFR departure procedure for a given runway and is intended for pilot awareness and use in the absence of ATC radar vectors or SID assignment. **Do not** publish text that allows an option to use a SID **or alternate maneuver assigned by ATC**; e.g., “Climb runway heading to 1200 before turning or use Manchester Departure” **or “Turn right, climb direct ABC VOR or as assigned by ATC.”**

(3) When using table 1, apply “before rounding” values to each situation to determine required action.

(4) An ODP may be either textually or graphically depicted within the following guidelines.

(a) Textual ODP. A relatively simple ODP may be published textually unless a graphical depiction is required for clarity. Textual ODP instructions that exceed a maximum of one turn, one altitude change, and one climb gradient must be published graphically.

(b) Graphic ODP. Complex ODPs are those that require a visual presentation to clearly communicate the departure instructions and desired flight paths. If the ODP is depicted graphically, it must be clearly stated on FAA Form 8260-15A, Takeoff Minimums and Textual

Departure Procedures (DP), in the *Departure Procedure* section; e.g., “USE JONES DEPARTURE.” The decision to graphically publish ODPs rests within **AeroNav Products**. When determining the need for a graphic DP, **AeroNav Products** must, in addition to the textual DP restrictions noted in paragraph 2-1b(4)(a), consider:

1. The number of ground-based NAVAIDs and fixes.
2. Whether graphical depiction will enhance pilot comprehension of the procedure.
3. The proximity and effect of precipitous or significant terrain.

(5) A graphic ODP may serve one or more runways at a single airport; e.g., a graphic departure may contain initial departure instructions for both Runways 9 and 27 on the same chart.

(6) ODPs must be developed with primary emphasis given to using the least onerous route (see appendix G) to the en route structure or at an altitude that will allow random (diverse) IFR flight, while accommodating commonly used routings out of each airport to the maximum extent practicable. Procedure designers must consider the impact on local ATC operations when using the phrases “before turning” or “before proceeding on course.” ODPs must be coordinated with ATC to ensure flight safety and compatibility with the local operating environment and the en route structure.

(7) ODPs may include a climb gradient when required for obstruction avoidance; however, ATC related climb gradients, speed and/or altitude restrictions must not be included in ODP development.

(8) Naming conventions and computer code assignments for graphic ODPs must follow the guidance specified for SIDs in appendix A to ensure controller awareness of route flown.

(9) Transition Routes are not permitted on graphic ODPs.

(10) ODPs must be developed using ground based NAVAIDs, RNAV, or dead reckoning guidance wherever possible. Radar vectors must not be specified for navigation guidance in ODP development. At those locations served by RNAV approaches exclusively, every effort must first be made to develop an ODP that accommodates conventional (preferably VOR) navigation systems. If this effort fails, an RNAV ODP must be developed.

(11) When a Visual Climb Over Airport (VCOA) has been established, publish a note that requires the pilot to inform ATC prior to departure when executing the VCOA.

(12) A VCOA maneuver must not be used in conjunction with an RNAV ODP.

(13) The VCOA requirement in table 1 is not mandatory at airports where ATC **cannot** allow the maneuver. In this case, annotate the exception and rationale in the “Reasons” portion of Form 8260-15A (**Form 8260-15B when a graphic ODP**).

(14) Textual ODPs may be designed to terminate at a fix/NAVAID located within the IFR en route structure and/or at an altitude that will allow random (diverse) IFR flight.

(15) Graphic ODPs must be designed to terminate at a fix/NAVAID located within the IFR en route structure.

Table 1. ODP Development Combinations.	
SITUATION	ACTION
1) TERPS diverse departure obstacle assessment does not identify any obstacle penetrations.	Complete Form 8260-15A documenting standard takeoff minimums apply.
2) TERPS diverse departure obstacle assessment identifies obstacles within the initial climb area (ICA) that require a CG greater than 200 ft per NM to an altitude of 200 ft or less, above Departure End of Runway (DER) (commonly referred to as “low, close-in obstacles”).	Establish a DP that provides the pilot a NOTE identifying the obstacle(s) type, location relative to DER, height (AGL), and elevation (MSL). See appendix D for recommended publication text available.
3) TERPS diverse departure obstacle assessment identifies obstacles that require a CG greater than 200 ft per NM, to an altitude greater than 200 ft above DER.	<p>A) Obstacles located within the ICA (extended) 3 SM or less from DER: Establish a DP using one of the following options (listed in order of preference):</p> <p>1) Publish a textual or graphic route/sector to avoid the obstacle(s) with standard takeoff minimums and standard CG, OR</p> <p>2) Publish a ceiling and visibility to see and avoid the obstacle(s) with the option of standard takeoff minimums with a minimum CG to a specified fix or altitude that provides obstacle clearance with a standard CG, AND;</p> <p style="padding-left: 40px;">a) Provide a NOTE identifying the obstacle(s), which specifies the obstacle description, location relative to the DER, height (AGL), and elevation (MSL), AND</p> <p style="padding-left: 40px;">b) For obstacles that penetrate the 40:1 OCS by 35 ft or less, provide an option to reduce takeoff runway length to accommodate the most penetrating obstacle based on a standard 200 ft per NM climb gradient, OR</p>

3) A combination of options 1) and 2) above.

B) All Other Obstacles: Establish a DP using one of the following options (listed in order of preference):

1) Publish a graphic or textual route/sector to avoid the obstacle with standard takeoff minimums and standard climb, **OR**

2) Publish standard takeoff minimums with a minimum CG to a specified fix or altitude that provides obstacle clearance with a standard CG, **AND**

a) For obstacles that penetrate the 40:1 OCS by 35 ft or less, provide an option to reduce takeoff runway length to accommodate the most penetrating obstacle based on a standard 200 ft per NM CG, **AND/ OR**

b) Provide a ceiling and visibility sufficient to allow a visual climb over the airport (VCOA) to an altitude that will provide obstacle clearance [see paragraph 2-1b(11) and (12)], **OR**

3) A combination of options 1 and 2 above.

C) Both Action A) and B) Obstacles:

1) If the DP **highest** CG is based on an **obstacle \leq 3 SM from DER** (Action A), establish a DP using one of the following options (listed in order of preference):

a) Publish a graphic or textual route/sector to avoid the obstacle with standard takeoff minimums and standard climb, **OR**

b) Publish standard takeoff minimums **and** the minimum CG required to clear the **\leq 3 SM obstacle** to a specified fix or altitude that will provide subsequent obstacle clearance above all DP obstacles based on a standard 200 ft per NM CG, **AND**

1 Provide a ceiling and visibility to see and avoid the \leq 3 SM obstacle **and** the minimum CG required to clear **all other obstacles** outside the ICA (extended) to a

	<p>specified fix or altitude that provides obstacle clearance, AND</p> <p>2 For obstacles that penetrate the 40:1 OCS by 35 ft or less, provide an option to reduce takeoff runway length to accommodate the most penetrating obstacle based on a standard 200 ft per NM climb gradient, AND/ OR</p> <p>3 Provide a ceiling and visibility sufficient to allow a VCOA to an altitude that will provide obstacle clearance [see paragraphs 2-1b(11) and (12)],</p> <p>2) If the DP highest CG is based on all other obstacles (Action B), then Action B above applies.</p> <p>Note: Where a graphic route/sector is published, include on the chart: takeoff minimums, required CGs, and applicable obstacle data for each runway using the DP.</p> <p>D) If none of the above actions are feasible, an IFR departure must not be authorized.</p>
<p>4) TERPS diverse departure obstacle assessment identifies obstacles requiring a CG to 200 ft or less above DER and additional obstacles that require a CG to an altitude greater than 200 ft above DER.</p>	<p>Apply a combination of action items from situations 2) and 3).</p>

c. Standard Instrument Departures (SIDs). SIDs are developed to assist in meeting environmental, capacity, and air traffic control requirements. SIDs may be requested by specific ATC facilities, the military services, or other proponents to enhance operations. A SID also provides protection from obstacles and is depicted graphically; however, it will not contain the “(OBSTACLE)” designation following the procedure title on the chart, and may not be flown unless approved by ATC. The following rules apply to SIDs:

(1) SIDs must be designed to terminate at a fix/NAVAID depicted on an IFR en route chart, at an altitude that will allow random IFR flight, or at a position and altitude where ATC radar service is provided.

(2) When a SID is designed to incorporate radar vectors at the termination point, provide a heading for charting and incorporation into the avionics database in the event ATC instructions are not received prior to or at the termination fix.

d. Design Constraints. The following design constraints apply to all ODPs and SIDs:

(1) DPs must not require a turn prior to reaching 400 ft above the departure end of runway (DER) elevation. See Order 8260.3, Volume 4, and Order 8260.44 when a turn is required within 2 NM of DER.

(2) DPs requiring a climb gradient (CG) in excess of 500 ft per NM, whether for obstacle clearance or air traffic control restrictions, must be approved by Flight Standards Service or appropriate DoD authority. Approval requests will be assessed by the FAA Flight Technologies and Procedures Division (AFS-400), Procedures Review Board (PRB).

Note: Consideration for approval will be based on, but not limited to, potential users/aircraft capability of meeting such a CG, and location of the obstruction along the projected flight track that is causing the CG.

(a) Requests for approval of climb gradients in excess of 500 ft per NM must include documentation showing the calculations used to derive the climb gradient values.

(b) When Flight Standards Service will not approve a climb gradient (CG) in excess of 500 ft per NM and all of the obstacles forcing such a CG are located inside the ICA (extended) 3 SM or less from DER, a ceiling and visibility may be applied to see and avoid the obstruction(s) as the only option available.

(c) When Flight Standards will not approve a climb gradient (CG) in excess of 500 ft per NM and any of the obstacles forcing such a CG are located outside the ICA (extended) greater than 3 SM from DER; a stand-alone VCOA procedure may be used as the only option available for obstacle avoidance.

(3) Speed restrictions may be specified only when absolutely necessary to ensure obstacle clearance, airspace efficiency during turns, or when necessary to achieve an operational advantage. Refer to applicable DP criteria directives.

(a) ATC required speed restrictions are only allowed in SID design and must not be included in ODPs.

(b) Speed restrictions (except as noted in paragraph 2-1d(3)(c)) must be limited to one restriction per fix/waypoint. In this instance, a minimum altitude based on the minimum required climb gradient must also be specified at the fix/waypoint.

(c) Avoid using multiple speed restrictions at the same fix for different aircraft types, insofar as possible; e.g., "Turbo-props do not exceed 160 KIAS until passing GARVY; Turbo-jets do not exceed 230 KIAS until passing GARVY." When multiple restrictions must be applied to support ATC operations, apply only one restriction for each aircraft type.

(4) Fan markers must not be used as a fix to designate a turning point on a SID or ODP.

(5) Do not establish VCOA procedures in conjunction with a SID.

e. Charting Constraints. The following charting constraints apply to all DPs:

(1) Charting Altitudes. Document altitudes for charting as follows:

(a) Graphic departure procedures may require depiction of a minimum altitude at a fix established along the departure route. SIDs may require altitudes to support ATC requirements; however, ATC required altitudes must not be depicted on ODPs. When the obstacle clearance and ATC altitudes at the same fix/waypoint are different values, the higher ATC required altitude then becomes the minimum altitude that will support obstacle clearance/procedure design constraints.

(b) Only a single, at or above altitude will be published at a fix. However, when ATC requires publication of a maximum, “at or below” altitude to support an operational requirement, a minimum “at or above” altitude must also be specified. This will make the actual charted altitude appear as a mandatory “at” altitude or as a block altitude; i.e., a combination of both an “at or above” and “at or below” altitude. Government and civil charting organizations will depict these altitudes according to their individual specifications.

(c) When an altitude restriction is requested by ATC for a fix located on a transition route, it must be at or above the specified minimum en route altitude (MEA) for the route.

(d) Enter altitudes to be charted on the appropriate 8260-15 series form (see appendix D or E).

(2) Charting Minimum Climb Gradients. All Graphic DPs must depict minimum climb gradient(s) that exceed 200 ft per NM whenever required for obstruction clearance and/or RNAV or RNP operational limitations (LNAV engagement altitude). Order 8260.3 allows only one climb gradient for obstacle clearance on any DP (ODP or SID). Multiple ATC climb gradients are permitted on SIDs; however, the ATC climb gradient must not be less than that required for obstacle clearance. When RNAV/RNP operational (equipment requirements) climb gradients are required on SIDs, these climb gradients must not be less than that required for obstruction clearance. Enter minimum climb gradients for charting on the appropriate 8260-15 series form (see appendix D or E).

(3) Charting Speed Restrictions. Required speed restrictions must be identified per Interagency Air Cartographic Committee (IACC) specifications.

(a) Speed restrictions for textual ODPs will follow the departure instructions; e.g., “...climbing right turn direct XXX VOR. Do not exceed 200 KIAS until XXX VOR.”

(b) Speed restrictions for graphic ODPs will be annotated on the chart at the restriction point.

(c) ATC SID speed restrictions will be identified by placing “(ATC)” at the end of the stated restriction; e.g., “Do not exceed 230 KIAS until passing BRAVO (ATC).” This will indicate to the pilot and the controller that this restriction is for ATC purposes and can be deleted by ATC. The absence of “(ATC)” at the end of a speed restriction indicates that it is there to support a TERPS criteria design constraint and **CANNOT** be modified or deleted by ATC.

(4) ODPs that are depicted graphically must have the term “(OBSTACLE)” printed on the graphic (see appendix D or E). This will be indicated by the word “OBSTACLE” adjacent to the “Type” line on Form 8260-15B. U.S. Government charts will include this immediately following the procedure title; e.g., TETON ONE DEPARTURE (OBSTACLE).

(5) ODPs developed for RNAV use must have the terms (OBSTACLE) and (RNAV) printed on the graphic. This will be indicated by the words “OBSTACLE” and “RNAV” adjacent to the “Type” line on Form 8260-15B. U.S. Government charts will include this immediately following the procedure title; e.g., LASCH ONE DEPARTURE (OBSTACLE) (RNAV).

(6) All Graphic DPs must include applicable takeoff minimums, climb gradients, obstacle data (see table 1), on the graphic chart, even if redundant to information published textually.

(7) A Radar Vector Area (RVA) used in conjunction with an RNAV SID may be published on the same chart with an RNAV route departure from a different runway; however, both must contain the same common segment prior to reaching the end of the departure (see appendix E, section 2 for unique database coding requirements).

f. Equipment Requirements. DPs are also categorized by equipment requirements as follows:

(1) Non-RNAV DP. A DP established for aircraft equipped with conventional avionics using ground-based NAVAIDs; e.g., nondirectional beacon (NDB), very high frequency omni-directional range (VOR), VHF omni-directional range/tactical air navigation (VORTAC), localizer (LOC), etc. These DPs may also be designed using dead reckoning navigation.

(2) RNAV DP. A DP established for aircraft equipped with RNAV avionics; e.g., global positioning system (GPS), FMS, etc. Automated vertical navigation must not be required.

(3) Radar SID. A SID established when ATC has a need to vector aircraft on departure to a particular ATS Route, NAVAID, or fix. Radar vectors may also be used to join conventional or RNAV navigation SIDs. SIDs requiring radar vectors must be annotated “RADAR REQUIRED.”

g. Terminology. The following terminology applies for initial climb instructions:

(1) When required, departure instructions must specify the actual heading to be flown after takeoff. Example: “Climb heading 350.10....” Some existing procedures specify “Climb runway heading.” Over time, these procedures will be updated, changing the terminology to specify the actual heading being flown.

Note: For database coding, heading/track/course values must be in hundredths of a degree. For charting purposes, these heading/track/course values will be rounded to the nearest whole degree. Additionally, hundredths of a degree must not be used in ATC communications.

(2) If departure instructions require a heading to be assigned by ATC, use: “Climb on assigned heading for radar vectors to (name of fix/airway, etc.).”

(3) If departure instructions require a specific altitude to climb to after takeoff, do not use the terminology “Climb to (altitude) ...” without including a heading to fly. Example: “Climb heading 310.25 to 1500 ...”

(4) Do not use the terminology “Climb straight ahead...” or “Maintain runway track...,” as there is no guidance or reference definition of this phraseology for the pilot to apply.

(5) Ensure initial departure instructions that require altitude restrictions are written clearly and in order to be flown so as to lessen the possibility of pilot deviations. For example, “Climb heading 240.15 to 1500, cross TEB 4.5 DME at 1500, then climb and maintain 2000, thence...” or, “Climb heading 195.47 to 900, then climbing right turn heading 280 to maintain 2000, thence...”

(6) A departure procedure requiring a turn does not require an initial climb heading to be specified. For example, “Climbing right turn direct XYZ VOR...” Direction of turn must be specified when turn exceeds 15 degrees.

(7) Do not use the word “immediate/immediately” in any type of departure instructions; e.g., turning instruction or speed restrictions. Old “early turn” departure procedures may contain instructions to “Turn left (right) as soon as practicable.” This terminology is only to be used on non-standard departure procedures approved by Flight Standards or the appropriate military authority.

2-2. Responsibilities.

a. General. The following guidance outlines procedures for DP requests, processing, and cancellation.

(1) Procedure Requests. SIDs are normally requested by the ATC facility responsible for departure control at the airport where the procedure is proposed, or by another proponent. All requests for new or amended SIDs must be processed through the Service Area Operations Support Group (OSG), Flight Procedures Team (FPT) and will forward to the appropriate Regional Airspace and Procedures Team (RAPT) in accordance with Order 8260.43.

(2) Requirements. ATC must provide the OSG, FPT, detailed operational requirements and restrictions for inclusion in the SID design. AeroNav Products must make every effort to meet ATC identified operational requirements and constraints using current criteria and policy. When current criteria and policy will not support a design to meet ATC requirements, AeroNav Products, AFS-420, and other ATO organizations/involved parties must work together to find an acceptable solution.

(3) Cancellation. All proposed SID cancellations must be approved by the RAPT. AeroNav Products has sole responsibility for canceling ODPs.

b. Proponent. A proponent's request to develop a DP must include the information in appendices B and C. This information must be completed and forwarded to the ATC facility providing departure control service to the airport for acceptance, prior to development. The DP request package must include the following:

- (1) An outline of the type of procedure and expected benefits.
- (2) A proposed ground track, including associated fixes and any proposed altitude or speed restrictions.
- (3) A request (if required) for development assistance from the servicing ATC facility.

c. ATC. When assisting a proponent or requesting a SID, the ATC facility providing departure control service must:

- (1) Evaluate the proponent's request to ascertain preliminary operational feasibility and to determine/verify that significant benefits (see appendix B) will be derived.
- (2) Assist in designing the procedure by providing the proponent with information pertaining to traffic flow and operational constraints; e.g., routes, minimum IFR altitudes, facility/sector lateral and vertical airspace boundaries, special use airspace, etc.

Note: When an ATC facility proposes SID development from an airport served primarily by air carriers, it may attempt to solicit the assistance of a "lead carrier" in the design and flyability of the proposed procedure.

- (3) Coordinate with other ATC facilities affected by the procedure.
- (4) Act as the focal point for all ATC coordination and provide appropriate assistance in resolving any problems identified during the development process.
- (5) Ensure that a DME/DME screening model has been run on RNAV SIDs to determine if the procedure is useable by suitably equipped aircraft, prior to submission.

Note: The DME/DME assessment process is contained in Order 7470.1, DME/DME Infrastructure Evaluation for Area Navigation (RNAV) Routes and Procedures.

(6) Coordinate with the servicing ARTCC to obtain a 5-letter pronounceable name for all fixes in the graphic DP. Complete Form 8260-2 data worksheet for each fix being established, modified, or canceled (see appendix C). Include the worksheet(s) as part of the graphic DP request package. Existing fixes/NAVAIDs should be used where conveniently located.

(7) Coordinate with the servicing ARTCC to obtain a name and computer code for the SID as specified in appendix A.

(8) Complete the DP requirements data worksheet (see appendix B), when applicable.

(9) Forward the requested package to the applicable Service Area Operations Support Group. The package must contain worksheets for all fixes, the DP requirements data worksheet, and a sketch of procedures requiring graphic publication (see appendix D or E).

(10) Review SIDs at least biennially for continued need. Coordinate requested changes through the applicable Service Area Operations Support Group, Flight Procedures Team.

d. The Service Area Flight Procedures Team (FPT) must:

(1) Review the DP package for completeness.

(2) Review DPs for impact by current or proposed Obstacle Evaluation/Airport Airspace Analysis (OE/AAA), Facilities and Equipment, National Change Proposal (NCP), or other applicable projects.

Note: The point-of-contact (POC) and telephone number for the ATC facility is listed on the Graphic DP requirements worksheet. The FPT must contact the POC to resolve any problems in developing the requested procedure and provide appropriate alternatives. The POC must be responsible for additional coordination of changes required for development. The FPT should coordinate with the Regional NextGen Branch (RNGB) for assistance where necessary.

(3) Facilitate discussion of the procedure at the RAPT.

(4) Forward the DP package to AeroNav Products.

(5) Provide one copy of each 8260-2 and 8260-15 series form(s) to all affected ATC facilities.

(6) The OSG FPT will notify the requesting ATC facility of the anticipated publication date and any delay in the publication and cause.

e. AeroNav Products must:

(1) Develop and process textual ODPs on FAA Form 8260-15A, Takeoff Minimums and Obstacle Departure Procedures, under applicable directives.

(2) Develop and process graphic ODPs and SIDs on FAA Form 8260-15B, Graphic Departure Procedure.

(3) Develop and process a FAA Form 8260-15C, Departure Data Record, for all RNAV DPs.

(4) Ensure that a DME/DME screening model has been run on RNAV “obstacle” departures (The Service Area OSG is responsible for DME/DME screening of SIDs) to determine if the procedure is useable by suitably equipped aircraft, prior to submission for flight inspection.

Note: The DME/DME assessment process is contained in separate guidance.

(5) Submit DPs to Flight Inspection Operations Division, AJW-33, for necessary action.

(6) Ensure that textual ODPs submitted “concurrent” with a “proposed” SIAP are flight inspected prior to assigning an effective date for the SIAP via .26 messages.

(7) After satisfactory flight inspection, forward the original Form(s) 8260-2, Radio Fix and Holding Data Record, and original 8260-15 series forms to NFDC. Copies will be provided to Service Area Flight Procedures Team for distribution to all affected ATC facilities (see paragraph 2-2d(5)).

(8) Develop, review, track, and cancel NOTAMs relating to ODPs and SIDs.

(9) Review ODPs periodically for continued need, obstacle clearance, and compliance with current criteria and policy; and coordinate proposed changes with the appropriate ATC facility. When application of new criteria or a new obstacle affects an ODP/SID that requires adjustment to an obstacle-driven CG, all DPs must be evaluated to determine if other CGs require adjustment. If CG adjustments are required, they must be updated simultaneously in the same charting cycle.

(10) When a location currently has standard takeoff minimums and circumstances now require non-standard takeoff minimums and/or an ODP development, amend the current Form 8260-15A for the airport accordingly.

(11) When it is necessary to cancel a DP, process the appropriate Form 8260-15 as directed in paragraph 2-5d.

(12) Add the “T” symbol to the instrument approach procedure (IAP) **and SID** charts whenever the Form 8260-15A indicates any data entries other than Standard Takeoff Minimums.

Note: The “T” symbol **will not be placed** on graphic ODPs.

(13) Delete the “T” symbol from the IAP charts based on receipt of a Form 8260-15A that has “Standard” in the “Takeoff Minimums” and it applies to all runways. This symbol deletion applies when a Textual ODP is not published or when removal of textual ODP information is necessary based on a revised Form 8260-15A.

Note: The basic rule is that if an ODP is published (Text or Graphic), the “T” symbol is required on all approach charts to that airport. If an ODP is not published, a “T” symbol will not appear on approach charts.

(14) Issue P-NOTAMs to correct United States Government charting discrepancies and compilation errors required (see Order 8260.19, chapter 2, section 6).

f. Aviation Systems Standards must:

- (1) Coordinate and execute Flight Validation and Flight Inspection for FAA developed procedures and under a reimbursable agreement with third party procedure developers,
- (2) Provide flight inspection results and archived reports upon request, and
- (3) Verify DME/DME coverage when applicable.

g. The NFDC must:

- (1) Conduct a pre-publication review of submitted forms to ensure compatibility with the National Airspace System Resources, National Database, and compliance with applicable directives relative to form entries.
- (2) Assign an effective date and publish textual and graphic ODPs in the transmittal letter (TL) authorizing charting agencies to publish the procedure.
- (3) Assign an effective date and publish graphic DPs, and associated fixes, in the daily National Flight Data Digest (NFDD) authorizing charting agencies to publish the procedure.
- (4) Coordinate to ensure the Form 8260-15B supporting graphic ODPs is published in the NFDD to be effective and charted concurrently with the associated Form 8260-15A.

(5) Monitor and track the status of concurrent instrument approach procedure (IAP) packages to ensure that the entire package is published with the same effective date.

(6) Notify AeroNav Products of delays in publication if the associated proposed procedures have not been flight checked or the associated docket has not received a final date by the applicable cutoff.

(7) Resolve data conflicts, form discrepancies, etc., with AeroNav Products.

(8) Review and track FDC NOTAMs relating to textual ODPs.

(9) File and maintain the original signed copy of the forms.

2-3. Accuracy Verification and Responsibilities. Any ATC facility, DoD, proponent, charting agency, procedure user, concerned individual, organization, or office must:

a. Notify AeroNav Products of published errors (including omissions) that affect safety of flight by the fastest means available. AeroNav Products must take appropriate NOTAM action under Order 8260.19.

b. Notify the NFDC whenever pre-publication errors are discovered in the TL or NFDD. The NFDC will coordinate corrective actions with AeroNav Products and promulgate corrected data/forms.

c. Notify AeroNav Products whenever charting discrepancies/compilation errors are detected in United States government published aeronautical products. AeroNav Products will coordinate corrective actions with AeroNav Products and NFDC.

2-4. Military Departure Procedures.

a. Military DPs are not handled or published in the same manner as civil DPs. Approval authority for DPs at military airports rests with the military. The FAA develops United States Army DPs under Order 8260.15, United States Army Terminal Instrument Procedures Service. The FAA develops United States Air Force DPs at domestic civil airports under Order 8260.32, United States Air Force Terminal Instrument Procedures Service. The National Geospatial-Intelligence Agency (NGA) publishes all military DPs.

Note: Military DPs must be named and numbered in accordance with the criteria outlined in this order.

b. The FAA requires that all military DPs be coordinated with FAA ATC facilities or regions when such DPs affect the NAS. The Air Traffic Facility providing the departure service must assist the military in coordinating the procedures and in obtaining computer codes to ensure that the procedures are properly interfaced with the NAS. United States Air Force and Navy procedures are NOT sent to NFDC.

c. When military DPs affect airspace under the jurisdiction of FAA facilities, those affected ATC facilities/ARTCCs must maintain copies of the applicable military or FAA procedure approval forms.

d. When a military DP has a climb gradient established to clear obstruction(s) that uses the “DoD Option” provision (see Order 8260.3, Volume 4, paragraph 1-4), the procedure must be annotated “NOT FOR CIVIL USE.”

2-5. FAA 8260-15 Series Forms (see appendices E and F).

a. The 8260-15 series forms document and facilitate transmittal of nonstandard takeoff minimums and/or departure procedures. These forms will be the basis for charting agencies to publish non-standard takeoff minimums, departure procedures, and/or to add/delete charting icons used to denote that other than standard takeoff minimums and/or specific obstacle departure procedures are published.

(1) Use Form 8260-15A.

(a) To document standard takeoff minimums.

(b) To document nonstandard takeoff minimums and/or higher than standard climb gradients for a runway.

(c) To document textual ODPs.

(d) To document that the ODP for a runway is published graphically.

(e) To document other pertinent textual data for publication; e.g., obstacle data notes, VCOA data, etc.

(2) Use Form 8260-15B.

(a) To document graphically depicted complex ODPs and all SIDs.

(b) To document other pertinent procedural data; e.g., fixes, NAVAIDs, routes, vectoring areas, altitudes, etc. required for charting database development on RNAV DPs.

(3) Use Form 8260-15C to document RNAV DPs in a manner consistent with and which aids in charting and database coding. Specifically use 8260-15C to document:

(a) The RNAV route of flight in terms of a series of segments defined by fix name, positions, waypoint type, leg types, course, and distance.

(b) Altitude and airspeed restrictions associated with fixes.

b. Use Form 8260-15A/B to deny lower than standard takeoff minimums. When touchdown and rollout runway visual range (RVR) are available on runways with centerline lights and either RVR is installed on a baseline GREATER than 250 ft, deny takeoff minimums lower than RVR 1200 by adding the following example standard NOTE on Form 8260-15:

“RWY 27R, Air Carrier reduction below RVR 1200 NA.”

c. Administratively process the 8260-15 series forms as specified in Order 8260.19, chapter 8. Additionally, when submitting procedures for waiver and/or Flight Standard approvals, include supporting documentation; e.g., for excessive climb gradient approval, submit documentation showing calculations.

d. Cancellation of Form 8260-15(s). Cancel specific takeoff minimums for an airport or cancel any textual or graphical DP(s) no longer required, as follows:

(1) Enter the current information from the top line of page 1 of Form 8260-15A/B and into the corresponding blocks on blank Forms 8260-15A and/or B. Additionally, on Form 8260-15B; complete the “Airports Served” section.

(2) Enter/Overprint “Canceled effective ____” in the “Takeoff Minimums” section on Form 8260-15A and/or “DP Route Description” section of Form 8260-15B (a stamp may be used for this purpose). This effective date will “normally” be entered by NFDC. The only time the “canceled effective” date must be entered by AeroNav Products is when a specific effective date is required.

Appendix A. Guidelines for the Design of Graphic Instrument Departure Procedures (DPs)

1. General.

a. Safety is a primary concern and DPs must be designed so that they provide obstacle clearance, least onerous routing (where possible), and can be confidently and consistently flown by all aircraft expected to use the procedure.

b. A DP must be relatively simple and easily understood. To avoid chart complexity and human factors concerns, limit the number of airports and/or runways from which a particular DP may be used to only those necessary to support operations.

c. A DP should use only the minimum number of fixes, turns, or altitude changes necessary to depict the route.

d. A DP should be developed to accommodate as many different types of aircraft as possible.

e. A DP should avoid the use of distance measuring equipment (DME) arcs.

f. Graphic ODPs must be designed to terminate at a fix/NAVAID located within the IFR en route structure or at an altitude that will allow random IFR flight.

g. A SID must provide for a significant user/system benefit.

h. A SID must reduce pilot/controller communications and workload.

i. A SID must be designed to terminate at a fix/NAVAID depicted on an IFR en route chart, at an altitude that will allow random IFR flight, or at a position where ATC radar service is provided.

j. Avoid Speed Restrictions Whenever Possible. See paragraphs 2-1d(3) and 2-1e(3) for specific guidance.

k. Altitude.

(1) Limit the number of altitude requirements to the minimum necessary. ATC operational restrictions are not permitted on ODPs.

(2) Minimum and maximum “block” altitudes for the same fix/waypoint are permitted. The maximum altitude will be designated as an “(ATC)” altitude. If the minimum altitude in the block is also an ATC altitude, the “(ATC)” will be placed adjacent to the minimum altitude. This situation is discouraged because a third minimum altitude for obstacle clearance would be necessary, creating chart clutter and may cause confusion.

(3) Avoid using multiple altitude restrictions at the same fix for different aircraft types or departure runways; e.g., “Turbo-props cross GRAVY at-or-below 5000, Turbo-jets cross GRAVY at-or-above 6000” or “RWY 9: Cross XRRAY at 9000; RWY 27: Cross XRRAY at 11000.”

(4) Define crossing altitude restrictions as “At,” “At or Above,” “At or Below,” or “Expect.” Avoid “At” and “At-or-Below” altitudes whenever possible.

Note: “Expect” altitude restrictions will not be coded.

(5) Procedure designers must use good judgment and common sense, coupled with operational input where available, to restrict procedural altitudes due to precipitous terrain.

1. Climb Gradient (CG). DPs are designed assuming a minimum standard CG of 200 ft/NM to ensure required obstacle clearance is achieved. Higher CGs must be published when required for obstruction clearance and ATC altitude requirements. See paragraphs 2-1d(2) and 2-1e(2) for specific guidance.

2. Naming of DPs (see pages B-6 through B-9 for examples).

a. Textual ODPs are not named, while all graphic ODPs and SIDs must be named as described in this section.

b. SIDs designed using radar vectors as the only navigation source to the en route environment, are normally named to correspond with the terminal control facility name. For example, the SID from Tampa International Airport is named the TAMPA THREE; the SID from Greater Cincinnati Airport is named the CINCINNATI EIGHT. If the terminal control facility name is already in use, use a fix, city, airport, or geographical area name in that order.

c. SIDs designed using a diverse vector area and radar vectors to a common specified route must be named to correspond to the fix/NAVAID/waypoint where the specified route ends. For example, the SID uses a diverse vector area and radar vectors to a fix/NAVAID/waypoint that begins a specified route to COTEE; the SID is named the COTEE ONE.

d. DPs designed using conventional, RNAV guidance must be named to correspond with the en route fix/NAVAID name where the DP ends. For example, a DP from Altoona-Blair County Airport that ends at the TATES fix is named the TATES TWO. If the DP is an RNAV procedure, the “(RNAV)” must be included in the name; for example, TATES TWO (RNAV).

e. If two or more DPs end at the same fix/NAVAID, the second and subsequent procedures must be named for the city, airport, or geographical area in that order. For example, a SID from Greater Cincinnati Airport that ends at the REDSS fix is named the REDSS FOUR. A SID from Cincinnati-Lunken Airport that also ends at the REDSS fix is called the LUNKEN SEVEN.

f. Number Each Original DP “ONE.” Number subsequent revisions in numerical sequence through NINE and then start over with ONE. Renumber graphic ODPs/SIDs whenever a revised FAA 8260-series form is required.

3. Transition Naming. DP transition names must always correspond with the fix/NAVAID where the transition ends. For example, the FORT LAUDERDALE SEVEN DEPARTURE termination fix is the Fort Lauderdale VORTAC (FLL) and it has a transition to the ZAPPA intersection; the transition name is ZAPPA. The REDSS FOUR DEPARTURE terminates at the REDSS fix and it has a transition to the Johnstown VORTAC (JST); the transition name is JOHNSTOWN.

4. Computer Identification Codes (see pages B-6 through B-9 for examples).

a. Textual ODPs will not receive a computer identification code.

b. Graphic ODPs and SIDs. Computer identification codes are assigned to graphic DPs by using the abbreviated name of the DP; e.g., a NAVAID or airport **3-letter** NAVAID or airport identifier, a 4-letter geographical abbreviation, or a **5-letter** fix/waypoint name, or other **5-letter** code, followed by the current DP number, then a dot, followed by the fix/NAVAID identifier where the DP ends. For example, the CINCINNATI EIGHT DEPARTURE in appendix A, paragraph 2b is coded “CVG8.CVG;” the FORT LAUDERDALE SEVEN DEPARTURE in appendix A, paragraph 3 is coded “FLL7.FLL;” and the “TATES TWO DEPARTURE in appendix A, paragraph 2d is coded “TATES2.TATES.” A computer identification code is not required for radar vector SIDs that do not contain a specified or common route published as part of the SID; i.e., a SID based solely on radar vectors to the en route structure.

c. SID Transition. SID transition computer codes are assigned by using the SID identifier and number as noted in appendix A, paragraph 4b, followed by a dot, followed by the identifier of the en route fix where the transition ends. Using the Fort Lauderdale example in appendix A, paragraph 3, the ZAPPA transition is coded “FLL7.ZAPPA.” Using the REDSS example in appendix A, paragraph 3, the Johnstown transition is coded “REDSS4.JST.”

5. RNAV DPs. The following general criteria and guidelines apply only to DPs designed for exclusive use by certain RNAV equipped aircraft. See the latest edition of Order 8260.44 for specific guidance and criteria.

a. Waypoints. Specify all waypoints as either fly-by or fly-over.

- (1) Use fly-by waypoints whenever possible.
- (2) Use fly-over waypoints only when operationally necessary or for obstacle clearance.
- (3) Design procedures using the fewest number of waypoints.

b. Leg Types. Table A-1 shows permissible leg types for use with RNAV DPs. See Order 8260.44 for leg type definitions and examples.

Table A-1. Permissible Leg Types.		
FROM	VIA (leg type)	TO
AER	VI ¹	See ¹
AER	VA ²	ALT
AER	VM ⁸	HDG
ALT	CF ³ , DF ⁴	FB/FO
AER	CF ³ , DF ⁴	FB/FO
FB	TF ⁵	FB/FO
FO	DF ⁴ , TF ⁵	FB/FO
IF ⁴	DF ⁴ , TF ⁵	FB/FO
FO	VM ⁸	HDG
FB	RF ⁶	FB

¹ VI (Heading-to-intercept) may only be used as the first leg of a departure and must be followed by a CF leg.

² VA (Heading-to-an-altitude) may only be used as the first leg of a departure and must be followed by a DF leg.

³ CF (Course-to-fix) may only be used as the first leg of a departure or as the leg following a departure VI leg.

⁴ DF (Direct-to-fix) may be used as the first leg of a departure, the leg following a departure VA leg, and for any leg thereafter preceded by a FO WP only.

⁵ TF (Track-to-fix) is not used as the first leg of a departure. TF is the preferred leg after the first leg of a departure.

⁶ RF (Constant radius arc) may only be used when necessary because some users do not have RF capability. An RF leg may only be used after a TF, CF, or another RF leg.

⁷ IF (Initial fix) is used to designate the first fix of a departure transition, i.e., the IF is coincident with the DP termination fix. IF is also used to designate the point at which RNAV begins when used in conjunction with radar vectors.

⁸ VM (Vector-to-fix) legs are only to be used in conjunction with ATC radar vectoring.

Note: AER - approach end of runway, ALT - altitude, FB/FO – fly-by fix/fly-over fix.

c. Leg Length.

(1) Use the Longest Legs possible. The designer must consider speed and course changes when determining minimum leg length. See Order 8260.44 for specific minima.

(2) There is no maximum leg length for straight-line paths. Exception: Do not develop leg lengths in the en route environment exceeding 260 miles to ensure the geodesic path does not exceed the protected airspace for a great circle path.

d. Levels of Criteria and Standard Required Navigation Performance (RNP) Levels.

Order 8260.44 criteria are divided into three classifications: Levels 1, 2, and 3. Use of the various levels is described below.

(1) Level 3 criteria. Do not use these criteria for “public” RNAV DP development (i.e., procedures developed using Level 3 criteria will become Special procedures).

Note: Level 3 criteria can be found in Order 8260.40, Flight Management System (FMS) Instrument Procedures Development.

(2) Level 2 criteria are the standard for RNAV DP terminal development and correspond to an en route level of aircraft navigation performance.

(3) Level 1 criteria apply narrower obstacle clearance areas than Level 2 and correspond to a terminal level of aircraft navigation performance. Level 1 criteria are used only under one or all of the following conditions:

(a) When developing RNP departure procedures.

(b) **When** environmental conditions or obstacles require the use of more stringent criteria than Level 2.

e. Chart Annotation.

(1) RNAV-1 will be the default designation for RNAV DPs. Annotate procedures with a standard note: “RNAV-1” on FAA Form 8260-15B (see appendix E).

(2) RNP-1 (in-lieu-of RNAV-1) will be used when a DP that contains an RF leg or when surveillance (Radar) monitoring is not desired for when DME/DME/IRU will be used. Annotate the procedure with a standard note: “RNP-1” on FAA Form 8260-15B (see appendix E).

(3) All RNAV DPs will contain a note that describes the equipment sensor limitations. Notes, as appropriate, are as follows:

Note 1: DME/DME/IRU or GPS Required

Note 2: GPS Required

(4) A note may be required to address the need for specific DME facilities to be operational. These are referred to as “critical DME facilities.”

Example:

Note: For Non-GPS Equipped aircraft, ABC, JKL, and XYZ DMEs Must Be Operational.

(5) **Except as required by paragraph 2-1f(3),** all “RNAV-1” DPs that are annotated “DME/DME/IRU or GPS REQUIRED” must be annotated with the note: “RADAR REQUIRED FOR NON-GPS EQUIPPED AIRCRAFT.”

EXAMPLES:

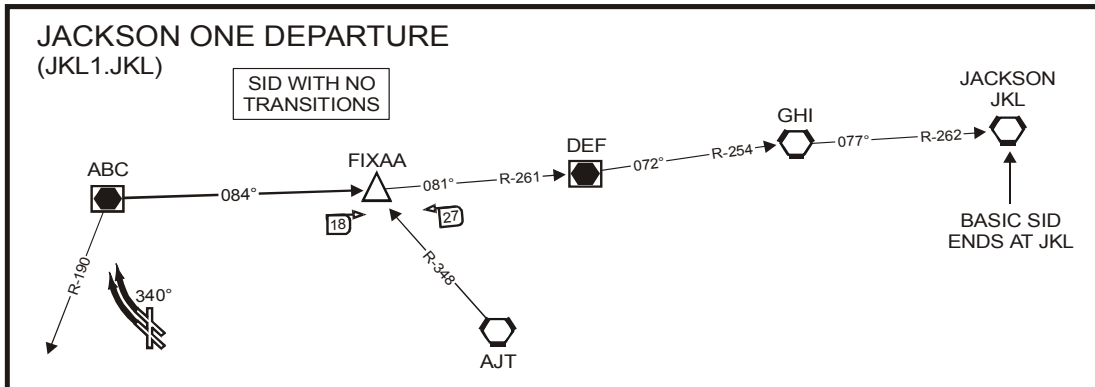
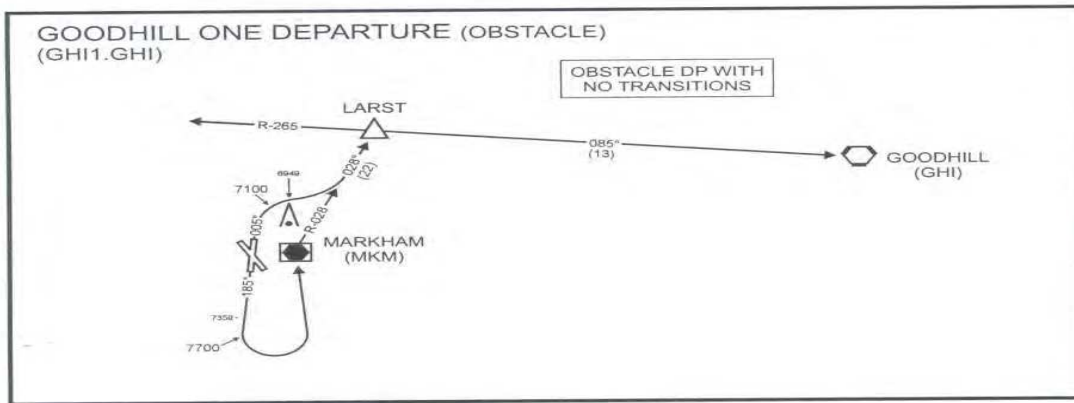

EXAMPLES (Continued):

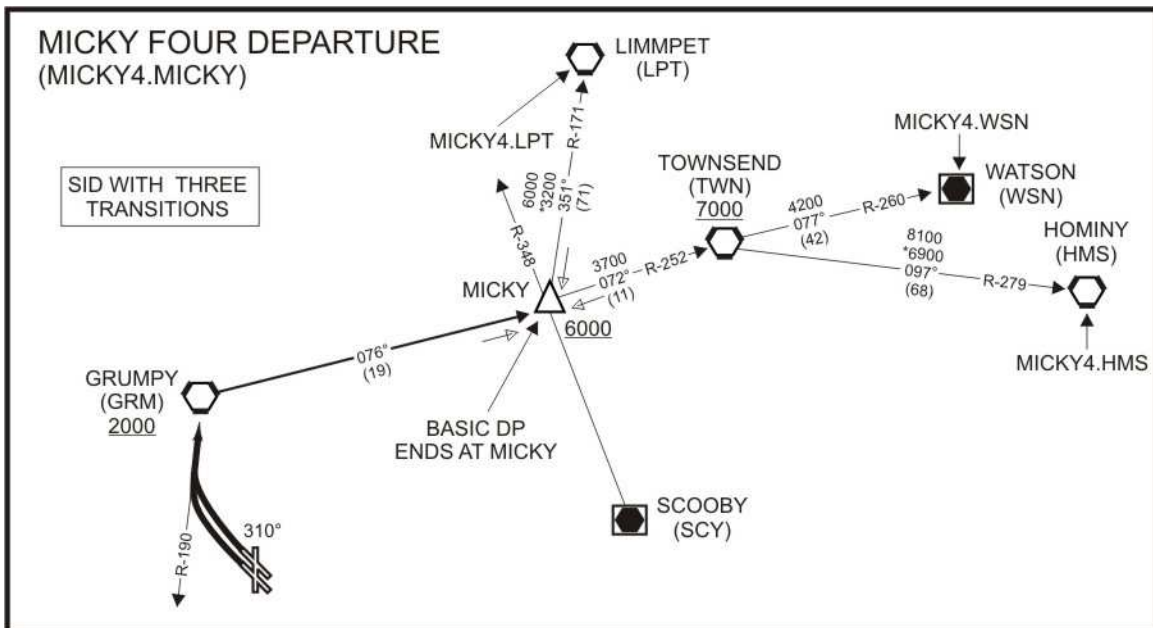
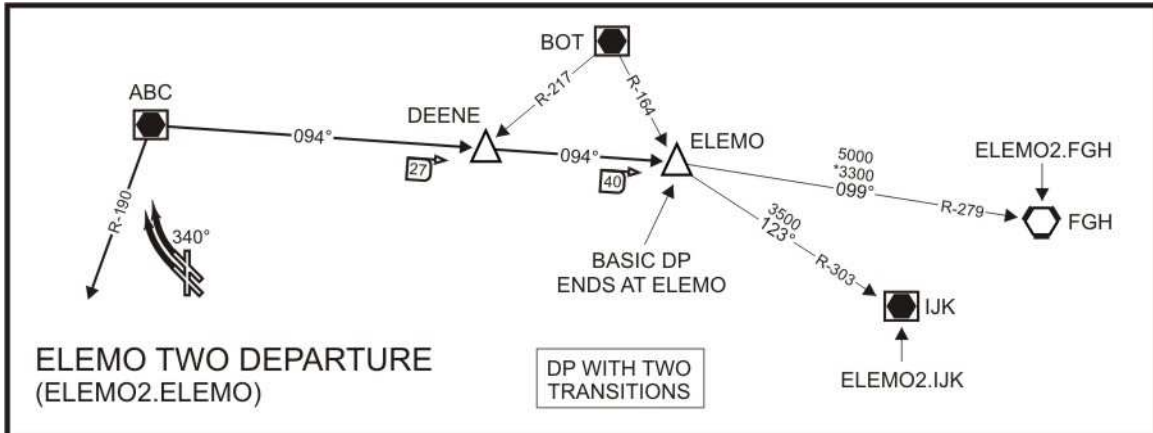

EXAMPLES (Continued):

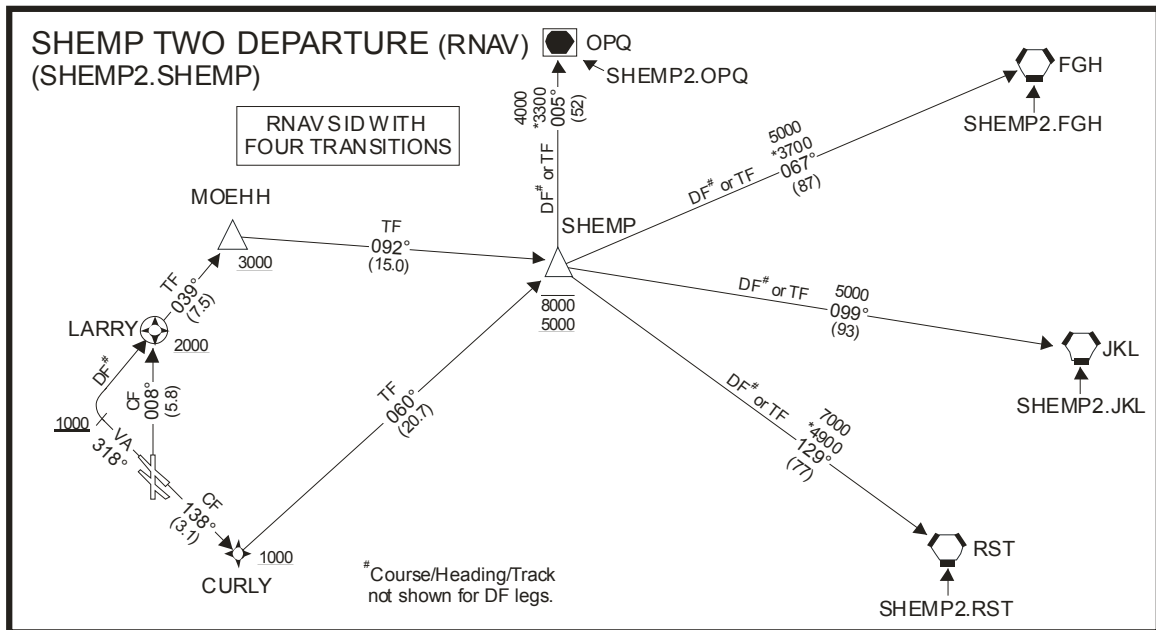
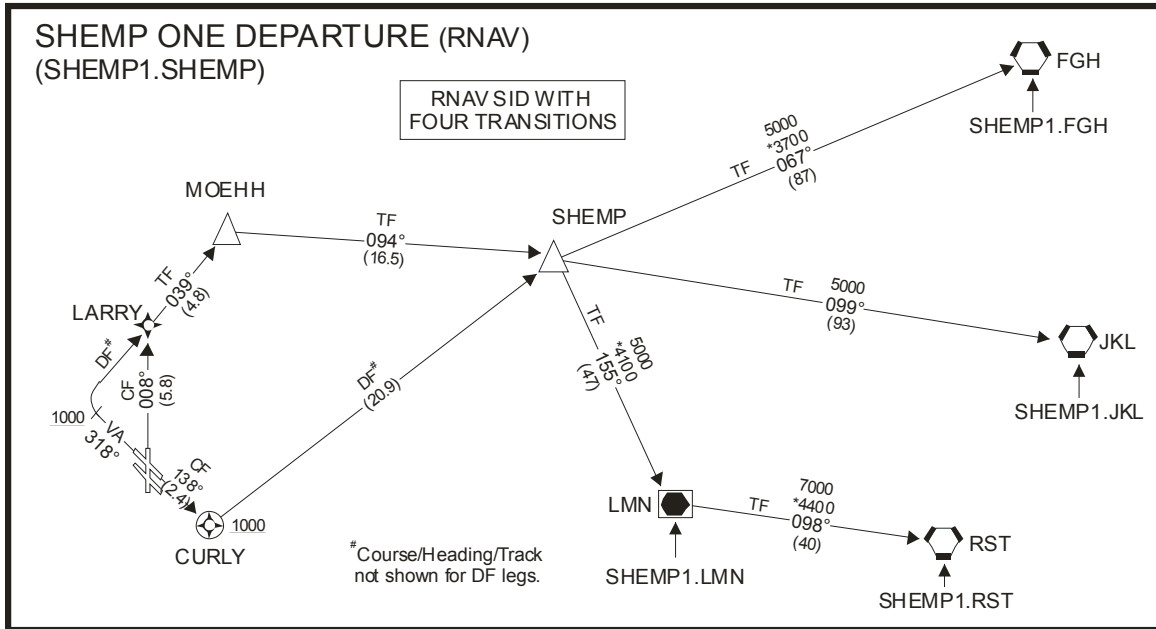

EXAMPLES (Continued):

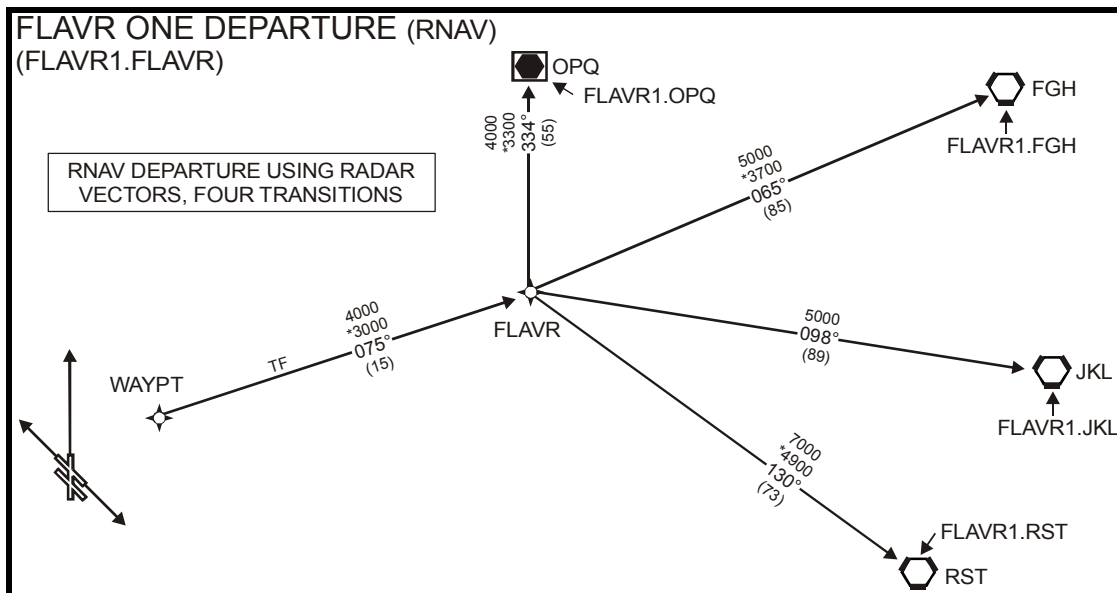
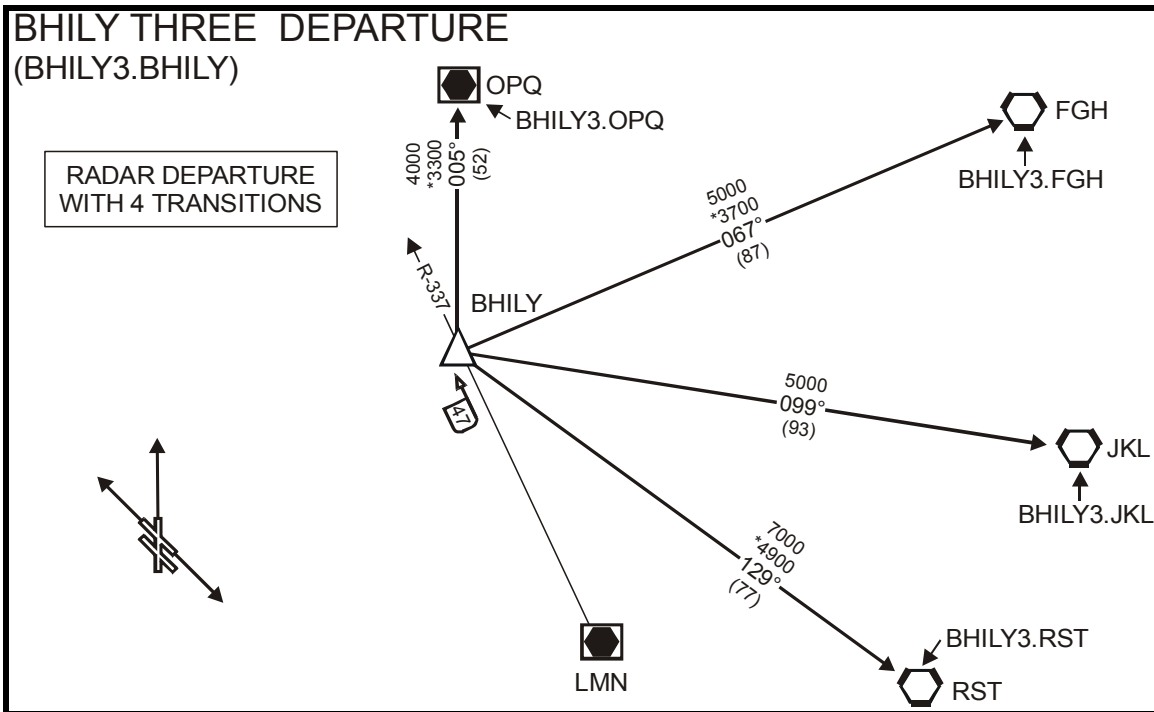

Appendix B. Instructions for Completing Graphic Departure Procedure (DP) Requirements Worksheet

Instructions for completing the graphic departure procedure requirements worksheet by **other** than **AeroNav Products** personnel.

Note: Proponents with the capability may use electronically generated 8260-15 series forms (with graphic depiction included) instead of the Graphic DP Requirements Worksheet.

This worksheet may be used to process changes to existing DPs. In such cases, only complete those **Lines** needed to convey the request/recommendation.

1. **Line 1. Airport(s).** Enter the name(s) of the airport(s) and the ICAO identifier(s) of each.
2. **Line 2. City and State.** Self-explanatory.
3. **Line 3. DP Name and Computer Codes.** Enter the proposed name of the DP and computer code. Use the naming and computer code conventions as outlined in appendix A. Coordinate the proposed name(s) and code(s) with the servicing ARTCC to ensure there are no duplications.
4. **Line 4. Action Required.** Indicate whether a new procedure is being established or modifying an existing DP.
5. **Line 5. Communications.** Indicate the communications functions to be charted; e.g., ATIS, AWOS/ASOS, CTAF, clearance delivery, departure control, etc. List frequency(ies) only if different than what is currently published for the facility or unique to the procedure. Coordinate with ATC as necessary.
6. **Line 6. Route.**
 - a. **Line 6.1. Runway(s)/Helipads/Vertiports.** Indicate the runway number(s) or helipads/vertiports the DP will serve.
 - b. **Line 6.2. Initial Route From Runway.** Indicate the desired initial route(s) that is required. If known, specify the single heading/course, or range of headings (e.g., DVA headings) for each runway authorized for the SID.
 - c. **Line 6.3. ATC Requested Routing/Operational Parameters.** Enter any information that would assist the procedure developer by providing flexibility in ground tracks. For example, if ATC needs the departure track to go generally south and join a route at a specified point and the exact ground track is not important, so state. Conversely, if there is flexibility to the east but there is an operational constraint to the west, that information must be provided. In extraordinary cases, when exact ground track is the primary concern in RNAV DPs, specify desired routing. ATC should specify the routing based on ATC needs.

d. Line 6.4. Fix(es). Enter each fix in the order flown. For the Departure IF, indicate either a specific point or at least describe the factors constraining the placement of the fix. Enter coordinates to the nearest 0.01 arc second when known. The TARGETS distribution package will satisfy this requirement. If used, enter the statement “See attached (DP name) TARGETS distribution package dated (date).”

Note: If an existing fix/NAVAID is used, enter only the fix name/facility type and ID, and any altitude restriction at the fix.

e. Line 6.5. ATC Required Altitudes. Enter any altitude restrictions associated with each fix.

7. Line 7. Transitions. [NA for Obstacle Departure Procedures (ODPs)]

a. Line 7.1. Identification. Enter the proposed name and computer code of each transition (see Block 3).

b. Line 7.2. Transition Fix(es). See Block 6.4.

c. Line 7.3. ATC Required Altitudes. See Block 6.5.

d. Line 7.4. ATC Operational Parameters. See Block 6.3.

8. Line 8. Lost Communications. List specific lost communications instructions if other than 14 CFR Part 91.185 (standard).

9. Line 9. Graphic Depiction. Provide a basic sketch of the procedure. The sketch may be hand drawn, computer generated, or overlaid on the appropriate portion of a controller chart. It is not necessary for the sketch to be to an exact scale. The intent here is to provide the procedure developer with a visual correlation of the textual route description.

10. Line 10. Requested Publication Date or Airspace Docket Number. Enter the desired effective date that coincides with the charting cycle. If the DP effective date is to be concurrent with an airspace action, enter the docket number, which may be obtained from the applicable ATO Service Area. See Order 8260.26, appendix A for chart dates and lead-time for submission.

11. Line 11. Remarks.

a. Indicate that the environmental review under Order 1050.1 (latest edition) and the noise screening have been accomplished.

Note: Notice 7210.360, Noise Screening Criteria for Certain Air Traffic Actions Above 3000 Feet, has expired; however, the noise screening is still required. The requirement will be re-established in a proposed Air Traffic environment order.

b. Enter appropriate information to clarify a data entry; e.g., airspeed restriction for air traffic, maximum altitude for aircraft performance, etc.

c. If the proposed DP does not meet the criteria requirements in paragraph 2-1 of this order, a statement of justification is necessary to explain why a DP is required. Avoid publication of unnecessary DPs.

12. Line 12. Point of Contact (POC). Self-explanatory.

THIS PAGE INTENTIONALLY LEFT BLANK

**Graphic Departure Procedure (DP)
Requirements Worksheet**

1. **Airport(s)** _____

2. **City and State** _____

3. **DP Name** _____ **Computer Code** _____

4. **Action Required:** Establish _____ Amend _____

5. **Communications:** Enter an X in the space provided next to the communications function listed. Enter the frequency when a nonstandard frequency has been specified.

ATIS _____ AWOS/ASOS _____ CLEARANCE DELIVERY _____ GROUND _____

TOWER _____ CTAF _____ DEPARTURE CONTROL _____ ARTCC _____

6. **Route:**

6.1. **Runway(s)** _____ **Helipads/Vertiports** _____

6.2. **Initial Route From Runway** _____

6.3. **ATC Requested Routing/Operational Parameters** _____

6.4. **Fix(es):**

NAME _____ NAVAID _____ LAT/LONG _____ ALT _____

NAME _____ NAVAID _____ LAT/LONG _____ ALT _____

NAME _____ NAVAID _____ LAT/LONG _____ ALT _____

NAME _____ NAVAID _____ LAT/LONG _____ ALT _____

NAME _____ NAVAID _____ LAT/LONG _____ ALT _____

NAME _____ NAVAID _____ LAT/LONG _____ ALT _____

NAME _____ NAVAID _____ LAT/LONG _____ ALT _____

6.5. **ATC Required Altitudes:** _____

**Graphic Departure Procedure (DP)
Requirements Worksheet (Continued)**

7. Transitions: [Not Allowed for graphic Obstacle Departure Procedures (ODPs)]

7.1 Identification:

NAME _____ **COMPUTER CODE** _____

NAME _____ **COMPUTER CODE** _____

NAME _____ **COMPUTER CODE** _____

NAME _____ **COMPUTER CODE** _____

NAME _____ **COMPUTER CODE** _____

7.2 Transition Fix(es):

Note: If fix/NAVAID is currently published on an en route chart, enter only the fix name and/or facility ID, and required altitude.

NAME _____ **NAVAID** _____ **LAT/LONG** _____ **ALT** _____

NAME _____ **NAVAID** _____ **LAT/LONG** _____ **ALT** _____

NAME _____ **NAVAID** _____ **LAT/LONG** _____ **ALT** _____

NAME _____ **NAVAID** _____ **LAT/LONG** _____ **ALT** _____

NAME _____ **NAVAID** _____ **LAT/LONG** _____ **ALT** _____

NAME _____ **NAVAID** _____ **LAT/LONG** _____ **ALT** _____

NAME _____ **NAVAID** _____ **LAT/LONG** _____ **ALT** _____

7.3. ATC Required Altitudes: _____

7.4. ATC Operational Parameters: _____

8. Lost Communications: _____

**Graphic Departure Procedure (DP)
Requirements Worksheet (Continued)**

9. Graphic Depiction:

Note: Depiction must clearly portray intended routing, fixes, NAVAIDs, and altitudes to be used in the DP. A separate sheet may be used.

10. Request Publication Date or Airspace Docket Number _____

11. Remarks:

12. Point-of-Contact: _____

ATC Facility Name.

POC's Name.

Telephone Number.

FAX Number.

E-Mail Address.

THIS PAGE INTENTIONALLY LEFT BLANK

Appendix C. Instructions for Completing FAA Form 8260-2, Data Worksheet

Instructions for completing 8260-2, Data Worksheet, for **Air Traffic facilities requesting AeroNav Products initiation or modification of fixes (including “Fix Use” updates) associated with existing Part 95 routes, Part 97 approaches, SID or STARs. For others (e.g., non-FAA procedure developers, etc.) that will be using existing fixes maintained by AeroNav Products and only need to update the “Fix Use,” complete the form with as much information as possible and explain the addition or deletion in Block 9, Remarks.**

- 1. Line 1. Requested Publication Date.** Enter the desired effective date that coincides with the charting cycle (see the latest edition of Order 8260.26, appendix 1). If the Form 8260-2 request is to be in conjunction with an airspace action, obtain the docket number from the applicable ATO Service Area. For Form 8260-2 requests associated with a DP request, allow at least 20 weeks lead-time from the desired effective date.
- 2. Line 2. Fix Name.** Enter the 5-character pronounceable name obtained from ARTCC. Do not include “WP” as part of the name.
- 3. Line 3. Fix Type.** Indicate the type of fix; e.g., radar, WP (a geographical position), DME (fixes made up of a single radial/bearing and DME, or multiple DMEs), VHF (fixes made up of 2 VOR radials), VHF/LF (fixes made up of a VOR radial and an NDB bearing). Indicate all combinations that make up the fix.
- 4. Line 4. State.** Enter the state in which the fix is located.
- 5. Line 5. Location.** Latitude and longitude accurate to the hundredth of a second; e.g., 09.25 sec. NAVAID radial/bearing/distance values must also be entered to the appropriate hundredth value; e.g., 347.23°; 08.37NM.
- 6. Line 6. Type of Action Required.** Check applicable box to Establish, Modify, or Cancel the fix.
- 7. Line 7. Holding.** List holding patterns required at fix. Include minimum and maximum altitude required. Include speed if other than standard.
- 8. Line 8. Charting.** Indicate required charting; i.e., terminal, en route, SID, STAR, etc.
- 9. Line 9. Remarks.** Other airports/procedures associated with fix (if known). Justify the requirement for other than routine processing and charting. Include any other information that may assist in developing the fix.
- 10. Line 10. Point of Contact (POC).** Self-explanatory.

THIS PAGE INTENTIONALLY LEFT BLANK

Form 8260-2, Data Worksheet

- 1. **Requested Publication Date:** _____
- 2. **Fix Name:** _____
- 3. **Fix Type:** _____
- 4. **State:** _____
- 5. **Location:** _____
- 6. **Type of Action Required:** Establish Modify Cancel
- 7. **Holding:** _____
- 8. **Charting:** _____
- 9. **Remarks (Use additional paper if required):**

10. **Point of Contact (POC):** _____

ATC Facility Name.

POC's Name.

Telephone Number.

FAX Number.

E-Mail Address.

THIS PAGE INTENTIONALLY LEFT BLANK

**Appendix D. Section 1. Instructions for Completing
FAA Form 8260-15A, Takeoff Minimums and
Obstacle Departure Procedures (ODP) and Sample Forms**

1. Develop a separate Form 8260-15A for each airport with approved instrument procedures. If all runways are standard (e.g., no ODP required), then state “Standard.” The form must encompass all runways for that airport. Use table 1 as a guide to initiate the required “Action” to support the “Situation” for a specific airport.

2. City and State. Complete this section with the same location data as on the associated approach procedure(s).

3. Airport. Complete this section with the same airport name data as on the associated approach procedure(s).

4. Effective Date. Leave blank. The National Flight Data Center (NFDC) will normally add the effective date. Enter an effective date only when a specific effective date is required; e.g., Magnetic Variation (Mag Var) rotation. If the procedure is a “Special,” enter “Special” on this line.

5. AMDT No. Enter standard entry as on Standard Instrument Approach Procedures (SIAP).

6. Takeoff Minimums. Enter takeoff minimums as directed below; however, do not list Take-off Minimums for the runway(s) served by a graphic ODP - see appendix D, paragraph 7a(6).

a. List the runway(s) that are not authorized for IFR departures. If none of the actions listed in table 1 are feasible, or if another reason(s) precludes ODP development (noise abatement, environmental, etc.), an IFR departure must not be authorized.

Examples:

RWY 27, NA - OBSTACLES.

RWY 35, NA - ENVIRONMENTAL.

RWY 17, NA - OBSTACLES AND NOISE ABATEMENT.

Followed by:

b. List the runway(s) authorized standard takeoff minimums.

Example:

RWY 09, 31 STANDARD.

Followed by:

c. List the runway(s) that have any *deviations* from standard minimums and/or restrictions;

Example:

TAKEOFF MINIMUMS: RWY 13, 400-2 OR STANDARD WITH MINIMUM CLIMB OF 310 FT PER NM TO 900, OR ALTERNATIVELY, WITH STANDARD TAKEOFF MINIMUMS AND A NORMAL 200 FT PER NM CLIMB GRADIENT, TAKEOFF MUST OCCUR NO LATER THAN 1800 FT PRIOR TO DER.

(1) When obstacles in the initial climb area (ICA) cause a climb gradient to an altitude 200 ft or less above DER, before rounding, do not publish takeoff minimums or a climb gradient. Instead, identify the obstacle data by note for publication in the “Takeoff Obstacle Notes” section.

(2) When obstacles 3 SM or less from DER preclude standard takeoff minimums:

Note: The obstacle may be within or beyond ICA extended to 3 SM.

(a) Provide a Note identifying the obstacle(s) in the “Takeoff Obstacle Notes” section.

(b) Provide higher than standard takeoff minimums followed by the alternative of standard minimums with a specified climb gradient.

(c) Identify the obstacle data in the Controlling Obstacles section.

(3) When obstacles beyond 3 SM of DER preclude standard takeoff minimums:

(a) Provide standard takeoff minimums with minimum climb gradient requirements.

(b) Provide higher than standard takeoff minimums to allow a visual climb over the airport (VCOA). Use standard Note in the following format: RWY XX, (CIG/VSBY) for climb in visual conditions.

Example:

TAKEOFF MINIMUMS: RWY 9, STANDARD WITH MINIMUM CLIMB OF 310 FT PER NM TO 1400 OR ALTERNATIVELY, WITH STANDARD TAKEOFF MINIMUMS AND A NORMAL 200 FT PER NM CLIMB GRADIENT, TAKEOFF MUST OCCUR NO LATER THAN 1800 FT PRIOR TO DER OR 1100-2½ FOR CLIMB IN VISUAL CONDITIONS.

7. TEXTUAL Departure Procedure.

a. **When a specific departure route is necessary**, provide the complete text, by runway, for required DPs.

(1) When a climb to an altitude is necessary before turning, define the limitation as clear and simple as possible when limiting the initiation of a turn; e.g., “RWY 36 – CLIMB **HEADING 350.11** TO 2800 BEFORE TURNING LEFT.

Note: Procedure designers must consider the impact on local ATC operations when using such phrases as “before turning” or “before proceeding on course,” therefore coordinate these actions with ATC to insure compatibility with the local operating environment.

(2) When a DP routing is required and VOR or TACAN is used to define the route, use the format: **RWY 9 - CLIMBING LEFT TURN TO INTERCEPT ABC VORTAC R-310 TO 6000 BEFORE PROCEEDING ON COURSE.**

(3) When a DP routing is required and NDB is used to define the route, use course to or bearing from the NDB; e.g., **RWY 35 - CLIMB HEADING 350..., THEN CLIMBING RIGHT TURN TO INTERCEPT BEARING 020 FROM ABC NDB TO 6000 BEFORE PROCEEDING ON COURSE;** or **RWY 35 - CLIMB HEADING 030..., THEN ON COURSE 015 TO ABC NDB TO 4000 BEFORE PROCEEDING ON COURSE.**

(4) When a ODP routing permits a climb within a sector, define the courses to remain within in a clockwise fashion; e.g., “RWY 12 – CLIMB ON A HEADING BETWEEN 061 CW TO 228 FROM DEPARTURE END OF RUNWAY, OR MINIMUM CLIMB OF 260 FT PER NM TO 8700 FOR HEADINGS 229 THROUGH 300.”

(5) When a DP routing is required and a localizer course is used to define the route, use magnetic direction of localizer course to be flown; e.g., “**RWY 5 - CLIMB ON I-XXX LOCALIZER NE COURSE TO 3000 BEFORE TURNING.**”

(6) When the departure instructions must be graphically depicted, inform the pilot of the name of the default Obstacle DP, and submit an accompanying Form 8260-15B; e.g., Use standard Note: “**USE JONES DEPARTURE**” when the graphic obstacle DP serves all runways or use “**RWY 27 – USE SMITH DEPARTURE**” when the graphic obstacle DP serves only a specific runway.

(7) When the departure instructions must include directions to visually climb over the airport, provide specific guidance that includes a reference point, direction of flight (if applicable), and a minimum climb to altitude. **Additionally, the statement “When executing VCOA, notify ATC prior to departure” must be included at the end.**

Examples:

(a) RWY 19 – FOR CLIMB IN VISUAL CONDITIONS: CROSS HICKORY REGIONAL AIRPORT AT OR ABOVE 1200 FT MSL BEFORE PROCEEDING ON COURSE. **WHEN EXECUTING VCOA, NOTIFY ATC PRIOR TO DEPARTURE.**

(b) RWY 32 – FOR CLIMB IN VISUAL CONDITIONS: CROSS XYZ VOR SOUTHEAST BOUND AT OR ABOVE 4200 MSL THEN PROCEED ON XYZ R-150 TO HAMET. **WHEN EXECUTING VCOA, NOTIFY ATC PRIOR TO DEPARTURE.**

b. It is not appropriate to use the wording “Comply with ODP or....” This could be confusing and cause the pilot to use a different routing than was expected by ATC.

c. Do not use the phrase “...or comply with ATC instructions.” The pilot is aware that ATC instructions are to be complied with, when possible, and safety of flight is not compromised.

d. Specify a single obstacle DP. Do not provide an option to use a SID as the default ODP. For example, **do not use** “Climb runway heading to 1200 before turning or use Manchester Departure.”

8. Takeoff Obstacle Notes.

a. Enter a Note regarding obstacles found as a result of applying table 1, Situation 2 action and Situation 3, action “A.” Do not list Take-off Obstacle Notes for the runway(s) served by a graphic default Obstacle DP as described in appendix D, paragraph 7a(5).

Note: An adverse assumption obstacle (AAO) will not be identified/published as a “takeoff obstacle” because pilots are not familiar with the AAO concept. However, publishing a ceiling and visibility will allow for those situations where the CG cannot be achieved and still afford the pilot the opportunity to visually acquire and avoid any obstruction that could have been built without notice to the FAA.

b. The note must include the runway affected and inform the pilot of the obstacle(s) type and location relative to the DER, and height (AGL/elevation (MSL)). When there are obstacles on both sides of the runway centerline extended, note the most significant obstacles left and right of the runway centerline. Phrases such as “multiple antennas, numerous trees, etc.” are acceptable. Specify distances **1 NM or greater to the nearest whole and tenth of a NM (e.g., 2.1 NM FROM DER).** Specify distances less than 1 NM in feet (e.g., **1280 FT FROM DER).**

Examples:

Note: RWY 35, TREES 1280 FT FROM DER, 120 FT LEFT OF CENTERLINE, 50 FT AGL/1527 FT MSL.

Note: RWY 35, BUILDING 2.1 NM FROM DER, 160 FT LEFT OF CENTERLINE, 350 FT AGL/ 1927 FT MSL.

Note: RWY 17, MULTIPLE BUILDINGS 500 FT FROM DER, 350 FT RIGHT OF CENTERLINE, 50 FT AGL/1107 FT MSL. ANTENNA 6000 FT FROM DER, 1235 FT LEFT OF CENTERLINE, 200 FT AGL/1257 FT MSL.

Note: RWY 27, MULTIPLE TREES AND ANTENNAS BEGINNING 500 FT FROM DER, 350 FT RIGHT OF CENTERLINE, UP TO 110 FT AGL/1307 FT MSL.

c. These obstacle Notes must be published by charting agents.

9. Controlling Obstacles.

a. Document the controlling obstacle(s) found as a result of applying table 1, Situation 3 and/or Situation 4. Do not list Controlling Obstacles for the runway(s) served by a graphic default ODP as described in appendix D, paragraph 7a(5).

Note: For all DPs, the controlling obstacle is that obstacle which, having penetrated the 40:1 Obstacle Clearance Surface (OCS) causes the most adverse climb gradient and/or ceiling and visibility to be published.

b. Use the following format to list the runway affected, elevation, and type of obstacle, the coordinates to the nearest 0.01 second; e.g., **“RWY 32: 2049 FT MSL TERRAIN 341548.01N/ 0862101.05W”** or **“RWY 32: 2049 FT MSL TERRAIN 341548.01N/ 0862101.05W.”**

c. Document the obstacle(s) that mandated development of a specific textual ODP route. These obstacles are not considered the “controlling obstacles” because they are not a factor to the specified route being flown. This information will not be charted on the procedure. Document these obstacles as follows:

“OBSTACLES MANDATING ODP ROUTE DEVELOPMENT: RWY 36 - 2049 FT MSL ANTENNA 341658.01N/ 0863108.05W.”

10. Remarks. List information/data that is not normally charted; e.g., administrative data or notes for controller information (requested by ATC). However, if something does need to be charted, precede the text with the “Chart Note:” annotation. See Order 8260.19, paragraph 8-72g, for a chart note that is required if the ODP is a Special. General chart notes (not Takeoff Minimums or Departure Instructions Notes) need to include instructions to the chart organization to place the note at the bottom of the entry. Use the following format: **“Chart Note at bottom of entry:...”**

11. Flight Inspected By. Enter the name of the airspace system inspection pilot who conducted the flight inspection, and the date.

12. Developed By. Enter the name of the procedure specialist name and **AeroNav Products** branch. This individual must sign in the “developed by” space, and enter the date signed.

13. Approved By. Enter the name of **AeroNav Products** Manager, or his/her delegated representative. This individual must sign in the “approved by” space, and enter the date signed. If the procedure is a “Special,” this line will contain the name of and be signed by AFS-400.

14. Coordinated With. Specify the offices/organizations the procedure was coordinated with. DP coordination must be identical with the approach procedure coordination as outlined in Order 8260.19, Flight Procedures and Airspace, (latest edition), chapter 8.

15. Changes. List changes relating to data entries on page one.

16. Reasons. List reasons for changes relating to data entries on page one. Additionally, when a VCOA cannot be established, an explanation must be provided; e.g., “VCOA NOT ESTABLISHED AT ATC REQUEST DUE TO (REASON).”

17. Required Effective Date.

a. Enter the effective date as noted in Order 8260.19 (latest edition), chapter 8, except that “Proposed” dates may not be used for ODPs. Optimally, submit as routine.

Note: En route submission cutoff dates apply to graphic DPs.

b. If the Form 8260-15A represents a concurrent action, enter “CONCURRENT” followed by the necessary information; e.g., Airport ID, IAP name and amendment number; airspace action, or other event.

c. When documenting Standard Takeoff Minimums for all runways (No ODP required), enter “N/A.”

Figure D-1.

U.S. DEPARTMENT OF TRANSPORTATION - FEDERAL AVIATION ADMINISTRATION

TAKEOFF MINIMUMS AND OBSTACLE DEPARTURE PROCEDURES (ODP)

Bearings, headings, courses, tracks, and radials are magnetic. Elevations and altitudes are in feet, MSL. Altitudes are minimum altitudes unless otherwise indicated. Ceilings are in feet above airport elevation. Distances are in nautical miles. Visibilities are in statute miles or feet RVR unless otherwise indicated.

City, State	Airport	Effective Date	Amdt No.
MILES CITY, MT	MILES CITY/FRANK WILEY FIELD		ORIG

TAKEOFF MINIMUMS:
STANDARD

TEXTUAL DEPARTURE PROCEDURE:

TAKEOFF OBSTACLE NOTES:

CONTROLLING OBSTACLES:

REMARKS:

<u>FLIGHT INSPECTED BY:</u> JON P. DOE	FIOG	03/13/2011	<u>REQUIRED EFFECTIVE DATE:</u> N/A
<u>DEVELOPED BY:</u> JOE DEVELOPER	AJV-352	02/18/2011	
<u>APPROVED BY:</u> JOE MANAGER	AJV-352	03/14/2011	

COORDINATED WITH:
ATA, ALPA, APA, AOPA, NBAA, ARPT MGR, ZNY, ZDC

CHANGES:

REASONS:

FAA Form 8260-15A / August 2009 (Computer Generated) Page 1 of 1

THIS PAGE INTENTIONALLY LEFT BLANK

THIS PAGE INTENTIONALLY LEFT BLANK

Figure D-3.

U.S. DEPARTMENT of TRANSPORTATION - FEDERAL AVIATION ADMINISTRATION

TAKEOFF MINIMUMS AND OBSTACLE DEPARTURE PROCEDURES (ODP)

Bearings, headings, courses, tracks, and radials are magnetic. Elevations and altitudes are in feet, MSL. Altitudes are minimum altitudes unless otherwise indicated. Ceilings are in feet above airport elevation. Distances are in nautical miles. Visibilities are in statute miles or feet RVR unless otherwise indicated.

City, State	Airport	Effective Date	Amdt No.
LASKY, WY	LASKY REGIONAL		ORIG

TAKEOFF MINIMUMS:
RWY 18, 34: NA - OBSTACLES

TEXTUAL DEPARTURE PROCEDURE:
RWY 18, 36: USE GOODHILL DEPARTURE

TAKEOFF OBSTACLE NOTES:

CONTROLLING OBSTACLES:

REMARKS:

<u>FLIGHT INSPECTED BY:</u> JON P. DOE	FIQG	03/12/2011	<u>REQUIRED EFFECTIVE DATE:</u> Routine
--	------	------------	---

<u>DEVELOPED BY:</u> JOE DEVELOPER (JOHN TRAINEE)	AJV-352	02/20/2011	
--	---------	------------	--

<u>APPROVED BY:</u> JOE MANAGER	AJV-352	03/20/2011	
---	---------	------------	--

COORDINATED WITH:
ATA, ALPA, APA, AOPA, NBAA, ARPT MGR, LSK ATCT, LSK APP CON, ZLC, ZOB

CHANGES:

REASONS:

FAA Form 8260-15A / August 2009 (Computer Generated) Page 1 of 1

THIS PAGE INTENTIONALLY LEFT BLANK

THIS PAGE INTENTIONALLY LEFT BLANK

Figure D-5.

U.S. DEPARTMENT of TRANSPORTATION - FEDERAL AVIATION ADMINISTRATION

TAKEOFF MINIMUMS AND OBSTACLE DEPARTURE PROCEDURES (ODP)

Bearings, headings, courses, tracks, and radials are magnetic. Elevations and altitudes are in feet, MSL. Altitudes are minimum altitudes unless otherwise indicated. Ceilings are in feet above airport elevation. Distances are in nautical miles. Visibilities are in statute miles or feet RVR unless otherwise indicated.

City, State	Airport	Effective Date	Amndt No.
PITTSBURGH, PA	PITTSBURGH INTERNATIONAL		4

TAKEOFF MINIMUMS:
 RWY 10L, 10C, 10R, 28L, 28C, 28R, 14: STANDARD.
 RWY 32: 200 - 1 1/2 OR STANDARD WITH MINIMUM CLIMB OF 240 FT PER NM TO 1500, OR ALTERNATIVELY, WITH STANDARD TAKEOFF MINIMUMS AND A NORMAL 200 FT PER NM CLIMB GRADIENT, TAKEOFF MUST OCCUR NO LATER THAN 2100 FT PRIOR TO DER.

TEXTUAL DEPARTURE PROCEDURE:

TAKEOFF OBSTACLE NOTES:
 NOTE: RWY 10L: TREE 1387 FT FROM DER, 733 FT LEFT OF CENTERLINE, 59 FT AGL/1233 FT MSL. ROD ON OL TOWER, 4168 FT FROM DER, 910 FT LEFT OF CENTERLINE, 112 FT AGL/1282 FT MSL. TOWER 4175 FT FROM DER, 864 FT LEFT OF CENTERLINE, 112 FT AGL/1282 FT MSL. TREE 1463 FT FROM DER, 672 FT LEFT OF CENTERLINE, 38 FT AGL/1212 FT MSL.
 NOTE: RWY 10C: MULTIPLE TREES BEGINNING 3207 FT FROM DER, 461 FT LEFT OF CENTERLINE, UP TO 29 FT AGL/1263 FT MSL.
 NOTE: RWY 10R: MULTIPLE TREES BEGINNING 1082 FT FROM DER, 102 FT RIGHT OF CENTERLINE, UP TO 66 FT AGL/1265 FT MSL. OL ON MONITOR POLE 4590 FT FROM DER, 1124 FT LEFT OF CENTERLINE, 55 FT AGL/1241 FT MSL. POLE 4610 FT FROM DER, 1138 FT LEFT OF CENTERLINE, 55 FT AGL/1241 FT MSL.
 NOTE: RWY 28L: TREE 2272 FT FROM DER, 1109 FT LEFT OF CENTERLINE, 64 FT AGL/1223 FT MSL. TREE 39 FT FROM DER, 498 FT LEFT OF CENTERLINE, 55 FT AGL/1144 FT MSL.
 NOTE: RWY 28R: TREE 1810 FT FROM DER, 912 FT RIGHT OF CENTERLINE, 34 FT AGL/1273 FT MSL. BUSH 73 FT FROM DER, 477 FT LEFT OF CENTERLINE, 12 FT AGL/1215 FT MSL. POLE 645 FT FROM DER, 663 FT LEFT OF CENTERLINE, 20 FT AGL/1223 FT MSL.
 NOTE: RWY 14: TREE 968 FT FROM DER, 516 FT RIGHT OF CENTERLINE, 44 FT AGL/1158 FT MSL.
 NOTE: RWY 32: ANT ON OL TOWER, 1.1 NM FROM DER, 435 FT LEFT OF CENTERLINE, 105 FT AGL/1354 FT MSL. TOWER 6812 FT FROM DER, 497 FT LEFT OF CENTERLINE, 96 FT AGL/1342 FT MSL. LT ON POLE 454 FT FROM DER, 515 FT RIGHT OF CENTERLINE, 25 FT AGL/1173 FT MSL. MULTIPLE TREES BEGINNING 1717 FT FROM DER, 1108 FT RIGHT OF CENTERLINE, UP TO 61 FT AGL/1321 FT MSL. TREE 6074 FT FROM DER, 1272 FT RIGHT OF CENTERLINE, 61 FT AGL/1321 FT MSL. TREE 2577 FT FROM DER, 1108 FT RIGHT OF CENTERLINE, 74 FT AGL/1233 FT MSL. TREE 2480 FT FROM DER, 1118 FT RIGHT OF CENTERLINE, 33 FT AGL/1212 FT MSL.

CONTROLLING OBSTACLES:
 RWY 32: 1354 FT MSL TOWER 403032.06N-0801435.23W

REMARKS:

FLIGHT INSPECTED BY: JOHN P. DOE	FIGG	08/08/2011	REQUIRED EFFECTIVE DATE: 09/23/2010
--	------	------------	---

DEVELOPED BY:
 JOE DEVELOPER
 (JIM TRAINEE)

AJV-352	05/02/2011
---------	------------

APPROVED BY:
 JOE MANAGER

AJV-352	09/25/2011
---------	------------

COORDINATED WITH:
 ATA, ALPA, AOPA, NBAA, ARPT MGR, PIT APP CON, ZOB

CHANGES:
 1. RWY 32 ADDED CLIMB GRADIENT AND CEILING/VISIBILITY
 2. DELETED DEPARTURE PROCEDURES.

REASONS:
 1. NEW CONTROLLING OBSTACLE REQUIRED A CLIMB GRADIENT.
 2. DIVERSE DEPARTURE AUTHORIZED.

FAA Form 8260-15A / August 2009 (Computer Generated)
Page 1 of 1

THIS PAGE INTENTIONALLY LEFT BLANK

**Section 2. Instructions for Completing
FAA Form 8260-15B, Graphic Departure Procedure (DP)
[Non-RNAV Departure Procedures] and Sample Forms**

1. Title Line: The Title Line consists of the six following elements and will be filled in as noted.

a. DP Name. Enter name of departure procedure. For example, the CATHEDRAL SEVEN DEPARTURE is entered as CATHEDRAL.

b. Number. Enter departure procedure number (spelled out); e.g., EIGHT.

c. DP Computer Code. Enter computer identification code as coordinated with by ATC (see appendix A).

d. Superseded Number. Departure procedure number (spelled out) superseded by this procedure. Enter “None” for a new procedure.

e. Dated. Date of superseded procedure. Format: DD MMM YY.

f. Effective Date. Leave blank. The effective date will normally be added by NFDC. Enter an effective date only when a specific effective date is required; e.g., Mag Var rotation. If the procedure is a “Special,” enter “Special” on this line.

2. Type: Specify whether the procedure is a default obstacle departure procedure (see paragraph 2-1b) by placing “Obstacle” on this line **or** specify that the procedure is a “SID” when the procedure is initiated by ATC (see paragraph 2-1c).

Note: Attach an up-to-date, clear graphic depiction of the procedure. DO NOT include a textual description of transitions or departure route text.

3. DP Route Description. Provide the initial climb out instructions for each runway and a textual description of the departure route to the DP termination fix. Include only information pertinent to the departure procedure. If the DP route can be clearly understood from a graphic depiction, a complete textual description is not necessary. Simply state, “...then on depicted route.” Define crossing altitudes at fixes as follows:

a. Document ODP/SID crossing altitude restrictions in plain text; e.g., “**CROSS GRM VORTAC AT OR ABOVE** (altitude)”; **CROSS SHEMP AT OR ABOVE** (altitude), **AT OR BELOW** (altitude); “**CROSS EDDIE AT** (altitude).”

b. When an altitude restriction has been requested by ATC (not authorized for ODPs) at a fix in an initial SID routing (prior to reaching the SID termination fix) that is higher than the “minimum altitude” at the same fix/waypoint, the higher requested ATC altitude then becomes the minimum altitude that will support all requirements (i.e., obstacle clearance/procedure design constraints and the ATC requirement(s)).

c. When an “at or below” altitude restriction at a fix is necessary, compute the “minimum altitude” by applying a 200 ft per NM or the actual required nonstandard “minimum” climb gradient for obstruction clearance until reaching an altitude suitable for en route flight (refer to 14 CFR Part 91.177); then apply the provisions of TERPS Volume 1, paragraph 1730.

4. Transition Routes. (Not Authorized for ODPs)

a. Transition Name. Name each transition according to the name of the fix at the transition termination point entered in appendix D, paragraph 4d. Do not include the word “Transition.”

b. Transition Computer Codes. Enter computer code as coordinated with ATC (see appendix A).

c. From FIX/NAVAID. Fix/NAVAID where the basic DP ends; e.g., **DANNY INT, BICKR.**

d. To FIX/NAVAID. En route fix/NAVAID where each transition ends; e.g., **DANNY, BICKR.** If a transition has multiple segments, enter one line for each segment.

e. Course. Specify the course for each transition segment. Enter the actual magnetic course to the hundredth of a degree (see Order 8260.19, chapter 8). When documenting the course between facilities, provide this information for both facilities.

Example:

076.56 & 080.47 (TWN R-077 & WSN R-260)

Note: AeroNav Products will round for publication.

f. Distance. Specify the distance for each transition segment. Enter the distance to the hundredth of a mile (see Order 8260.19, chapter 8). When documenting the course/distance between facilities, provide this information for both facilities.

Example:

41.61

Note: AeroNav Products will round for publication.

g. MEA. Enter MEA along transition route. By definition, the MEA also encompasses the MRA. If transitions share a common segment, make sure the MEA for that segment is the same for each transition.

h. MOCA. Enter MOCA along transition route. To reduce chart clutter, MOCAs less than 500 ft below MEAs should not be published.

i. Crossing Altitudes/Fixes. When a **SID Transition(s)** must accommodate an ATC required altitude at a specified fix, only document the ATC altitude; e.g., **“BECKY at/above 9000.”** No secondary altitude is required on transition routes since an MEA is specified that will provide obstacle clearance and ensure design constraints are met. The ATC altitude must not be lower than the MEA.

5. Procedural Data Notes/Takeoff Minimums.

a. List any procedural data information that is to appear in note form on the graphic depiction; e.g., DME required, minimum climb rate information, etc. Also, depict all restrictions and performance requirements to fly the procedure. See Order 8260.19, paragraph 8-71g, for a chart note that is required if the SID/Graphic ODP is a Special.

Followed by:

b. List the runway(s) that are not authorized for IFR departures. If none of the actions listed in table 1 are feasible, or if another reason(s) precludes DP development (noise abatement, environmental, etc.), an IFR departure must not be authorized.

Examples:

RWY 27, NA - Obstacles.

RWY 35, NA - Environmental.

RWY 17, NA - Obstacles and noise abatement.

Followed by:

c. List the runway(s) authorized standard takeoff minimums.

Example:

RWY 09, 31 Standard.

Followed by:

d. List the runway(s) that have any *deviations* from standard minimums and/or restrictions.

Examples:

(1) TAKEOFF MINIMUMS: RWY 13, 400-2 OR STANDARD WITH MINIMUM CLIMB OF 310 FT PER NM TO 900, OR ALTERNATIVELY, WITH STANDARD TAKEOFF MINIMUMS AND NORMAL 200 FT PER NM CLIMB GRADIENT, TAKEOFF MUST OCCUR NO LATER THAN 1800 FT PRIOR TO DER.

(2) TAKEOFF MINIMUMS: RWY 27, STANDARD WITH MINIMUM CLIMB OF 280 FT PER NM TO 2500, OR ALTERNATIVELY, WITH STANDARD TAKEOFF MINIMUMS AND NORMAL 200 FT PER NM CLIMB GRADIENT, TAKEOFF MUST OCCUR NO LATER THAN 1800 FT PRIOR TO DER. ATC CLIMB OF 310 FT PER NM TO 4000.

(3) TAKEOFF MINIMUMS: RWY 36, ATC CLIMB OF 340 FT PER NM TO 8000.

Note: The option to reduce available runway length for takeoff is only applicable to obstacle driven climb gradient and not applied for ATC climb gradients.

6. Takeoff Obstacle Notes.

a. **Enter a Note regarding obstacles** found as a result of applying table 1, Situation 2 action and Situation 3, action “A” (see Form 8260-15A, Takeoff Obstacle Notes).

Note: An adverse assumption obstacle (AAO) must not be identified/published as a “takeoff obstacle” because pilots are not familiar with the AAO concept. However, publishing a ceiling and visibility will allow for those situations where the CG cannot be achieved and still afford the pilot the opportunity to visually acquire and avoid any obstruction that could have been built without notice to the FAA.

b. **The note must include the runway affected** and inform the pilot of the obstacle(s) type and location relative to the DER, and height (AGL/elevation (MSL)). When there are obstacles on both sides of the runway centerline extended, note the most significant obstacles left and right of the runway centerline. Phrases such as “multiple antennas, numerous trees, etc.” are acceptable. Specify distances 1 NM or greater to the nearest whole and tenth of a NM (e.g., 2.1 NM FROM DER). Specify distances less than 1 NM in feet (e.g., 1280 FT FROM DER).

Examples:

NOTE: RWY 35, TREES 1280 FT FROM DER, 120 FT LEFT OF CENTERLINE, 50 FT AGL/1527 FT MSL.

NOTE: RWY 35, BUILDING 2.1 NM FROM DER, 160 FT LEFT OF CENTERLINE, 350 FT AGL/ 1927 FT MSL.

NOTE: RWY 17, MULTIPLE BUILDINGS 500 FT FROM DER 350 FT RIGHT OF CENTERLINE, 50 FT AGL/1107 FT MSL. ANTENNA 6000 FT FROM DER, 1235 FT LEFT OF CENTERLINE, 200 FT AGL/ 1257 FT MSL.

NOTE: RWY 27, MULTIPLE TREES AND ANTENNAS BEGINNING 500 FT FROM DER, 350 FT RIGHT OF CENTERLINE, UP TO 110 FT AGL/1307 FT MSL.

c. **These obstacle Notes must be published by charting agents.**

7. Controlling Obstacles.

a. **Document the controlling obstacle(s)** found as a result of applying table 1, Situation 3 and/or Situation 4.

Note: For all DPs, the controlling obstacle is that obstacle which, having penetrated the 40:1 Obstacle Clearance Surface (OCS), causes the most adverse climb gradient and/or ceiling and visibility to be published.

b. **Use the following format** to list the runway affected, elevation and type of obstacle, the coordinates to the nearest 0.01-second; e.g., "**RWY 32: 2049 FT MSL Terrain 341548.01N/0862101.05W.**"

c. **Document the obstacle(s)** that mandated development of a specific graphic ODP route. These obstacles are not considered the "controlling obstacles" because they are not a factor to the specified route being flown. This information will not be charted on the procedure. Document these obstacles as follows:

"OBSTACLES MANDATING ODP ROUTE DEVELOPMENT: RWY 36 - 2049 FT MSL Antenna 341658.01N/ 0863108.05W."

8. **Lost Communications Procedures.** Air Traffic Control (ATC) is responsible for determining the need and content of lost communications instructions. Leave blank when procedures are the same as in 14 CFR Part 91.185 (standard).

9. **Additional Flight Data.** List any additional charting instructions, items essential to clarify charting or information a specialist has determined needs charting as other than a Note. Examples of data may include: terrain features, airports, Special Use Airspace (SUA), holding patterns, or takeoff and departure obstacles; e.g., **CHART _____ MOA; CHART HOLDING AT ICT VORTAC, HOLD NE, RT, 222.03 INBOUND (Include Leg Length for RNAV or DME Holding, when applicable and speed, if other than standard).** Ensure that the accompanying Form 8260-2 contains the appropriate documentation for holding patterns supporting the departure procedure.

10. **Airports Served.** List the official airport name(s), city, and 2-letter state code served by the departure procedure.

Note: An obstacle DP may only serve one airport.

11. **Communications.** Enter name of radio "**primary**" communications to be charted; e.g., ATIS, CTAF, Clearance Delivery, Departure Control, etc. Specify frequency only if different than what is currently published for the facility, or unique to the procedure.

12. **Fixes and/or NAVAIDs.** Enter only the fixes and/or NAVAIDs for which charting is requested but is not included in the DP route description of the departure or transition routes

13. **Remarks.** List information/data that is NOT to be charted; e.g., administrative data or notes for controller information (requested by ATC).

- 14. Flight Inspected By.** Enter the name of the airspace system inspection pilot who conducted the flight inspection, and date.
- 15. Developed By.** Enter the name of the procedure specialist developing the data, and AeroNav Products branch. This individual must sign in the “developed by” space, and enter the date signed.
- 16. Approved By.** Enter the name of AeroNav Products Manager, or his/her delegated representative. This individual must sign in the “approved by” space and enter the date signed. If the procedure is a “Special,” this line will contain the name of and be signed by AFS-400.
- 17. Coordinated With.** Specify the offices/organizations the procedure was coordinated with. Departure procedure coordination must be identical with the approach procedure coordination as outlined in Order 8260.19 (latest edition), chapter 8.
- 18. Changes.** List changes relating to data entries.
- 19. Reasons.** List reasons for changes relating to data entries.
- 20. Required Effective Date.**
- a. Enter the effective date** as noted in Order 8260.19 (latest edition), chapter 8, except that “Proposed” dates may not be used for graphic DPs. Optimally, submit as “routine.”
- Note:** En route data submission cutoff dates must apply for graphic DPs.
- b. If the Form 8260-15B represents a concurrent action,** enter “CONCURRENT” followed by the necessary information; e.g., Airport ID, IAP name and amendment number; airspace action, or other event.

Figure D-6.

U.S. DEPARTMENT OF TRANSPORTATION - FEDERAL AVIATION ADMINISTRATION
GRAPHIC DEPARTURE PROCEDURE (DP)

Bearings, headings, courses, tracks, and radials are magnetic. Elevations and altitudes are in feet, MSL. Altitudes are minimum altitudes unless otherwise indicated. Ceilings are in feet above airport elevation. Distances are in nautical miles (NM). Visibilities are in statute miles (SM) or feet RVR unless otherwise indicated. Graphic depiction attached.

DP Name **GOODHILL** Number **ONE** DP Computer Code **GHI1.GHI** Superseded Number **NONE** Dated Effective Date

Type: Obstacle

DP ROUTE DESCRIPTION:

TAKEOFF RWY 18: CLIMB HEADING 185.22 TO 7700, THEN CLIMBING LEFT TURN DIRECT MKM VOR/DME, THEN ON MKM R-028 TO LARST, THENCE...OR, CLIMB IN VISUAL CONDITIONS TO CROSS MKM VOR/DME NORTHEASTBOUND AT OR ABOVE 8100, THEN ON MKM R-028 TO LARST, THENCE...
TAKEOFF RWY 36: CLIMB HEADING 005.22 TO 7100, THEN CLIMBING RIGHT TURN TO INTERCEPT MKM R-028 TO LARST, THENCE...

... RIGHT TURN TO INTERCEPT GHI R-265 TO GHI VORTAC. CROSS GHI VORTAC AT OR ABOVE MEA/MCA FOR ASSIGNED ROUTE OF FLIGHT.

TRANSITION ROUTES (GRAPHIC DEPICTION ONLY):

Transition Name	Computer Codes	From Transition	FIX/NAVAID	To FIX/NAVAID	Course	Distance	MEA	MOCA	Crossing Altitudes/Fixes

PROCEDURAL DATA NOTES/TAKEOFF MINIMUMS:

TAKEOFF MINIMUMS: RWY 16,34 NA - OBSTACLES. RWY 36 STANDARD. RWY 18 STANDARD WITH MINIMUM CLIMB OF 380 FT PER NM TO 7700 OR 1800-3 FOR CLIMB IN VISUAL CONDITIONS. WHEN EXECUTING VCOA, NOTIFY ATC PRIOR TO DEPARTURE.

TAKEOFF OBSTACLE NOTES:

CONTROLLING OBSTACLES:

RWY 18: 7359 FT MSL TREES, 433303.44N/1104648.03W.
RWY 18 (VCOA): 7751 FT MSL TREES, 433807.67N/1104133.89W.
RWY 36: 6949 FT MSL TOWER, 433801.40N/1104220.06W.

LOST COMMUNICATIONS PROCEDURES:

U.S. DEPARTMENT OF TRANSPORTATION - FEDERAL AVIATION ADMINISTRATION
GRAPHIC DEPARTURE PROCEDURE (DP)

Bearings, headings, courses, tracks, and radials are magnetic. Elevations and altitudes are in feet, MSL. Altitudes are minimum altitudes unless otherwise indicated. Ceilings are in feet above airport elevation. Distances are in nautical miles (NM). Visibilities are in statute miles (SM) or feet RVR unless otherwise indicated. Graphic depiction attached.

DP Name: **GOODHILL** Number: **ONE** DP Computer Code: **GHI1.GHI** Superseded Number: **NONE** Dated: Effective Date:

ADDITIONAL FLIGHT DATA:

AIRPORTS SERVED:
LASKY REGIONAL LASKY, WY

COMMUNICATIONS:
ATIS, GND CON, TWR, ZLC

FIXES AND/OR NAVAID'S:

REMARKS:

FLIGHT INSPECTED BY:
Johnathan P. Doe

FIQG 4/15/2011

DEVELOPED BY:
Timothy S. Wisenheimer
(John Q. Public)

AJV-352 2/13/2011

APPROVED BY:
David P. Specialist

AJV-352 6/12/2011

COORDINATED WITH:

ATA, ALPA, AOPA, AOPA, NBAA, ARPT MGR, LSK ATCT, ZLC

CHANGES:

REASONS:

REQUIRED EFFECTIVE DATE:

Routine

Figure D-7.

U.S. DEPARTMENT OF TRANSPORTATION - FEDERAL AVIATION ADMINISTRATION
GRAPHIC DEPARTURE PROCEDURE (DP)

Bearings, headings, courses, tracks, and radials are magnetic. Elevations and altitudes are in feet, MSL. Altitudes are minimum altitudes unless otherwise indicated. Crossings are in feet above airport elevation. Distances are in nautical miles (NM). Visibilities are in statute miles (SM) or feet RVR unless otherwise indicated. Graphic depiction attached.

DP Name: **MICKY** DP Computer Code: **MICKY4.MICKY** Superseded Number: **THREE** Effective Date: _____
 Number: **FOUR**

Type: **SID**

DP ROUTE DESCRIPTION:

TAKEOFF RWY 31L/R: CLIMB ON HEADING 309.71 AND GRM R-190 TO CROSS GRM VORTAC AT OR ABOVE 2000, THEN RIGHT TURN TO INTERCEPT GRM R-076 TO CROSS MICKY AT OR ABOVE 6000. MAINTAIN 9000, EXPECT CLEARANCE TO FILED ALTITUDE AT MICKY.

TRANSITION ROUTES (GRAPHIC DEPICTION ONLY):

Transition Name	Computer Codes	From FIX/NAVAID	To FIX/NAVAID	Course	Distance	MEA	MOCA	Crossing Altitudes/Fixes
HOMINY	MICKY4.HMS TWN VORTAC	MICKY TWN VORTAC	71.64 (TWN R-072)	097.22 & 088.54 (TWN R-097 7 HMS R-279)	10.89 68.47	3700 8100	3700 6900	TWN AT/ABOVE 7000
LIMPET	MICKY4.LPT	MICKY	LPT VORTAC	351.19 (LPT R-171)	70.98	6000	3200	
WATSON	MICKY4.WSN TWN VORTAC	MICKY TWN VORTAC	071.64 (TWN R-072)	076.56 & 080.47	10.89 41.61	3700 4200	3700	TWN AT/ABOVE 7000

PROCEDURAL DATA NOTES/TAKEOFF MINIMUMS:

NOTE: THIS SID TO BE USED ONLY UPON ASSIGNMENT BY METRO TOWER, NORMALLY BETWEEN THE HOURS OF 2100-0600 LOCAL TIME. TAKEOFF MINIMUMS: RWY 13L, 13R, 18, 36 NA FOR THIS SID - NOISE ABATEMENT. RWY 31L: **MINIMUM** CLIMB OF 310 FT PER NM TO 2000. RWY 31R: 300-1 3/4 OR STANDARD WITH **MINIMUM** CLIMB OF 310 FT PER NM TO 2000 OR ALTERNATIVELY, WITH STANDARD TAKEOFF MINIMUMS AND A NORMAL 200 FT PER NM CLIMB GRADIENT, TAKEOFF MUST OCCUR NO LATER THAN 2100 FT PRIOR TO DER.

TAKEOFF OBSTACLE NOTES:

CONTROLLING OBSTACLES:

RWY 31L: 1049 FT MSL TOWER, 325304.00N/0965428.00W.
 RWY 31R: 739 FT MSL BUILDING, 325245.67N/0965221.00W.

LOST COMMUNICATIONS PROCEDURES:

U.S. DEPARTMENT OF TRANSPORTATION - FEDERAL AVIATION ADMINISTRATION
GRAPHIC DEPARTURE PROCEDURE (DP)

Bearings, headings, courses, tracks, and radials are magnetic. Elevations and altitudes are in feet, MSL. Altitudes are minimum altitudes unless otherwise indicated. Ceilings are in feet above airport elevation. Distances are in nautical miles (NM). Visibilities are in statute miles (SM) or feet RVR unless otherwise indicated. Graphic depiction attached.

DP Name	Number	DP Computer Code	Superseded Number	Dated	Effective Date
MICKY	FOUR	MICKY4.MICKY	THREE		

ADDITIONAL FLIGHT DATA:

AIRPORTS SERVED:

METRO-JETPORT, DALLAS, TX

COMMUNICATIONS:

ATIS, CLNC DEL, GND CON, TWR, DEP CON

FIXES AND/OR NAVAID'S:

SCY VOR/DME

REMARKS:

FLIGHT INSPECTED BY:

Johnathan P. Doe

FIQG

4/15/2010

REQUIRED EFFECTIVE DATE:

CONCURRENT WITH AIRSPACE DOCKET 10-ASW-28

DEVELOPED BY:

Timothy S. Wisenheimer
(John Q. Public)

AJV-352

2/13/2010

APPROVED BY:

David P. Specialist

AJV-352

6/12/2010

COORDINATED WITH:

ATA, ALPA, AOPA, NBAA, ARPT MGR, MET ATCT, REG ATCT, ZFW

CHANGES:

ADDED HMS TRANSITION

REASONS:

RAPT REQUEST

Figure D-8.

U.S. DEPARTMENT OF TRANSPORTATION - FEDERAL AVIATION ADMINISTRATION
GRAPHIC DEPARTURE PROCEDURE (DP)

Bearings, headings, courses, tracks, and radials are magnetic. Elevations and altitudes are in feet, MSL. Altitudes are minimum altitudes unless otherwise indicated. Ceilings are in feet above airport elevation. Distances are in nautical miles (NM). Visibilities are in statute miles (SM) or feet RVR unless otherwise indicated. Graphic depiction attached

DP Name: GOODHILL
Number: ONE
DP Computer Code: GH11.GHI
Superseded Number: NONE
Dated: _____
Effective Date: _____

Type:

DP ROUTE DESCRIPTION:

PROCEDURE CANCELLED

TRANSITION ROUTES (GRAPHIC DEPICTION ONLY):

Transition Name	Computer Codes	From	FIX/NAVAID	To	FIX/NAVAID	Course	Distance	MEA	MOCA	Crossing Altitudes/Fixes

PROCEDURAL DATA NOTES/TAKEOFF MINIMUMS:

TAKEOFF OBSTACLE NOTES:

CONTROLLING OBSTACLES:

LOST COMMUNICATIONS PROCEDURES:

ADDITIONAL FLIGHT DATA:

AIRPORTS SERVED:

COMMUNICATIONS:

FIXES AND/OR NAVAID'S:

U.S. DEPARTMENT OF TRANSPORTATION - FEDERAL AVIATION ADMINISTRATION
GRAPHIC DEPARTURE PROCEDURE (DP)

Bearings, headings, courses, tracks, and radials are magnetic. Elevations and altitudes are in feet. MSL. Altitudes are minimum altitudes unless otherwise indicated. Ceilings are in feet above airport elevation. Distances are in nautical miles (NM). Visibilities are in statute miles (SM) or feet RVR unless otherwise indicated. Graphic depiction attached.

DP Name: **GOODHILL** Number: **ONE** DP Computer Code: **GH11.GHI** Superseded Number: **NONE** Dated: Effective Date:

REMARKS:

FLIGHT INSPECTED BY:

REQUIRED EFFECTIVE DATE:
Routine

DEVELOPED BY:

Timothy S. Wisenheimer
(John O. Public)

AJV-352

2/13/2011

APPROVED BY:

David P. Specialist

AJV-352

6/12/2011

COORDINATED WITH:

CHANGES:

PROCEDURE CANCELED.

REASONS:

OBSTACLE DATA REVIEW - ODP NO LONGER REQUIRED.

*CONCURRENT WITH CANCELATION OF KLSK TAKEOFF MINIMUMS AND (OBSTACLE) DEPARTURE PROCEDURES. ORIG.

**Appendix E. Section 1. Instructions for Completing
FAA Form 8260-15B, Graphic Departure Procedures (DP)
[RNAV Departure Procedures] and Sample Forms**

1. Title Line: The title line consists of the following six elements and will be filled in as noted.

a. DP Name. Enter name of departure procedure. For example, the CATHEDRAL SEVEN DEPARTURE is entered as CATHEDRAL.

b. Number. Enter departure procedure number (spelled out); e.g., EIGHT.

c. DP Computer Code. Enter computer identification code coordinated with ATC (see appendix A).

d. Superseded Number. Departure procedure number (spelled out) superseded by this procedure. Enter “None” for a new procedure.

e. Dated. Date of superseded procedure. Format: DD MMM YY.

f. Effective Date. Leave blank. The effective date will normally be added by NFDC. Enter an effective date only when a specific effective date is required; e.g., Mag Var rotation. If the procedure is a “Special,” enter “Special” on this line.

2. Type: Specify “RNAV” on this line to indicate that this is an RNAV departure. Additionally, specify “OBSTACLE” when the procedure is the default obstacle departure procedure (see paragraph 2-1b), **or** specify “SID” when the procedure is initiated by ATC (see paragraph 2-1c).

Note: Attach an up-to-date, clear graphic depiction of the procedure. **DO NOT** include a textual description of transitions or departure route text.

3. DP Route Description. Provide the initial climb out instructions for each runway and a textual description of the departure route to the DP termination fix. Include only information pertinent to the departure procedure. If the DP route can be clearly understood from a graphic depiction, a complete textual description is not necessary. Simply state, “...then on depicted route.” Define crossing altitudes at fixes as follows:

a. Document ODP/SID **crossing altitude restrictions in plain text; e.g., “**CROSS GRM VORTAC AT OR ABOVE** (altitude)”; **CROSS SHEMP AT OR ABOVE** (altitude), **AT OR BELOW** (altitude)”; “**CROSS EDDIE AT** (altitude).”**

b. When **an altitude restriction has been requested by ATC (not authorized for ODPs) at a fix in an initial SID routing (prior to reaching the SID termination fix) **that is higher than the “minimum altitude” at the same fix/waypoint, the higher requested ATC altitude becomes the****

minimum altitude that will support all requirements (i.e., obstacle clearance/procedure design constraints and the ATC requirement(s)).

c. When an “at or below” altitude restriction at a fix is necessary, compute the “minimum altitude” by applying a 200 ft per NM or the actual required nonstandard “minimum” climb gradient for obstruction clearance until reaching an altitude suitable for en route flight (refer to 14 CFR Part 91.177); then apply the provisions of TERPS Volume 1, paragraph 1730.

Note: Information in this section must match the corresponding information in the Altitude column of the Form 8260-15C.

d. See table E-1 for specific wording and required information. Specify the turn direction as either “Left/Right” as follows:

- (1) DF legs. For all course changes exceeding 15 degrees.
- (2) CF and TF legs. For all course changes exceeding 90 degrees.

Note: If the DP route becomes a series of consecutive TF legs with turns less than or equal to 90 degrees, a complete textual description from that point is not necessary. Simply state, “...then on depicted route.” (See example, “TAKEOFF RWY 1”).

e. Document all courses, headings, tracks, and distances to the nearest hundredth unit of measurement.

Note: Fix/NAVAID column entries will be published verbatim on the AeroNav Services chart, with the exception of courses, headings, and tracks, which will be rounded by AeroNav Products to the nearest whole degree.

f. When using a VA, VI, or VM leg, specify the actual heading to be flown (e.g., do not use “climb on runway heading”). Ensure courses, tracks, headings, and distances entered on Form 8260-15B match the equivalent true values and distances entered on Form 8260-15C as appropriate.

Table E-1. Leg Type Wording and Required Information.		
8260-15C Leg Type	8260.15B Wording	8260.15B Required Information
VI	"heading"	heading
VA	"heading"	heading/altitude
DF	"direct"	turn direction* /distance**
CF	"course"	course/distance/turn direction***
TF	"track"	course/distance/turn direction***
VM	"heading"	Heading/altitude

* Do not specify turn direction when a DF leg is used as the first leg of a DP.

** Do not specify distance when part of a VA-DF leg combination.

*** Only specify turn direction for CF or TF legs when amount of turn exceeds 90°.

Examples:

VI leg followed by CF leg – “TAKEOFF RWY 32R: CLIMB HEADING 317.66 TO INTERCEPT COURSE 041.20 TO LARRY.”

VA leg followed by DF leg – “TAKEOFF RWY 32R: CLIMB HEADING 317.66 TO 1000, THEN RIGHT TURN DIRECT LARRY.”

CF leg - “TAKEOFF RWY 1: CLIMB ON COURSE 007.52 TO LARRY, THENCE...”

DF leg - “TAKEOFF RWY 14L: CLIMB DIRECT CURLY, THENCE...”

CF leg followed by TF legs (less than 90 degree course changes) – “TAKEOFF RWY 1: CLIMB ON COURSE 007.52 TO LARRY, THEN ON DEPICTED ROUTE TO SHEMP, THENCE...”

CF leg followed by DF leg – “TAKEOFF RWY 14L: CLIMB ON COURSE 137.64 TO CROSS CURLY AT OR ABOVE 1000, THEN LEFT TURN DIRECT SHEMP, THENCE...”

VM leg – “TAKEOFF RWY 35C: CLIMB HEADING 350.11 OR AS ASSIGNED BY ATC TO 3000, EXPECT VECTORS TO AIMEE, THENCE...”

4. Transition Routes. (Not Authorized for ODPs.)

a. Transition Name. Name each transition according to the name of the fix at the transition termination point entered in appendix E, paragraph 4d. Do not include the word “TRANSITION.”

b. Transition Computer Codes. Enter computer code as coordinated with ATC (see appendix A).

c. From FIX/NAVAID. Fix/NAVAID where each transition begins (normally, the en route fix where the DP ends); e.g., **DANNY, BICKR**.

d. To FIX/NAVAID. En route fix/NAVAID where each transition ends; e.g., **DANNY, BICKR**. If a transition has multiple segments, enter one line for each segment.

e. Course. Specify the course for each transition segment. Enter the actual magnetic course to the hundredth of a degree (see Order 8260.19, chapter 8). When documenting the course between facilities, provide this information for both facilities.

Examples:

DF leg – “DIRECT”, “RIGHT TURN DIRECT”, OR “LEFT TURN DIRECT”

CF leg – Not used for transition routing.

TF leg – “TRACK 067.11 ” or “RIGHT TURN, TRACK 054.94”

076.56 & 080.47 (TWN R-077 & WSN R-260)

Note 1: The VA or VI leg, when used, will be used only on the first leg of a departure and as such a VA/VI leg should not appear in the transition route.

Note 2: AeroNav Services will round for publication.

f. Distance. Specify the distance for each transition segment. Enter the distance to the hundredth of a mile (see Order 8260.19, chapter 8). When documenting the course/distance between facilities, provide this information for both facilities.

Example: 41.61 **Note:** AeroNav Services will round for publication.

g. MEA. Enter MEA along transition route. By definition, the MEA also encompasses the MRA. If transitions share a common segment, make sure the MEA for that segment is the same for each transition.

h. MOCA. Enter MOCA along transition route. To reduce chart clutter, MOCAs less than 500 below MEAs should not be published.

i. Crossing Altitudes/Fixes. When a **SID Transition(s)** must accommodate an ATC required altitude at a specified fix, only document the ATC altitude; e.g., “**BECKY AT/ABOVE 9000.**” No secondary altitude is required on transition routes since an MEA is specified that will provide obstacle clearance and ensure design constraints are met. The ATC altitude must not be lower than the MEA.

5. Procedural Data Notes/Takeoff Minimums.

a. List any procedural data information that is to appear in note form on the graphic depiction; e.g., minimum climb rate information, etc. Also, depict all restrictions and performance requirements to fly the procedure. See appendix A, paragraph 5e, for specific information that must be charted and entered in this section. See Order 8260.19, paragraph 8-71g, for a chart note that is required if the SID/Graphic ODP is a Special.

Followed by:

b. List the runway(s) that are not authorized for IFR departures. If none of the actions listed in table 1 are feasible, or if another reason(s) precludes DP development (noise abatement, environmental, etc.), an IFR departure must not be authorized.

Examples:

RWY 27, NA - OBSTACLES.

RWY 35, NA - ENVIRONMENTAL.

RWY 17, NA - OBSTACLES AND NOISE ABATEMENT.

Followed by:

c. List the runway(s) authorized standard takeoff minimums.

Example:

RWY 09, 31 STANDARD.

Followed by:

d. List the runway(s) that have any deviations from standard minimums and/or restrictions;

Examples:

TAKEOFF MINIMUMS: RWY 13, 400-2 OR STANDARD WITH MINIMUM CLIMB OF 310 FT PER NM TO 900, OR ALTERNATIVELY, WITH STANDARD TAKEOFF MINIMUMS AND A NORMAL 200 FT PER NM CLIMB GRADIENT, TAKEOFF MUST OCCUR NO LATER THAN 1800 FT PRIOR TO DER.

TAKEOFF MINIMUMS: RWY 27, STANDARD WITH MINIMUM CLIMB OF 280 FT PER NM TO 2500, OR ALTERNATIVELY, WITH STANDARD TAKEOFF MINIMUMS AND A NORMAL 200 FT PER NM CLIMB GRADIENT, TAKEOFF MUST OCCUR NO LATER THAN 1800 FT PRIOR TO DER. ATC CLIMB OF 310 FT PER NM TO 4000.

TAKEOFF MINIMUMS: RWY 36, ATC CLIMB OF 340 FT PER NM TO 8000.

Note: The option to reduce available runway length for takeoff is only applicable to obstacle driven climb gradient and not applied for ATC climb gradients.

6. Takeoff Obstacle Notes.

a. Enter a NOTE regarding obstacles found as a result of applying table 1, Situation 2 action and Situation 3, action “A.”

Note: An adverse assumption obstacle (AAO) must not be identified/published as a “takeoff obstacle” because pilots are not familiar with the AAO concept. However, publishing a ceiling and visibility will allow for those situations where the CG cannot be achieved and still afford the pilot the opportunity to visually acquire and avoid any obstruction that could have been built without notice to the FAA.

b. The note must include the runway affected and inform the pilot of the obstacle(s) type and location relative to the DER, and height (AGL/elevation [MSL]). When there are obstacles on both sides of the runway centerline extended, note the most significant obstacles left and right of the runway centerline. Phrases such as “multiple antennas, numerous trees, etc.” are acceptable. Specify distances 1 NM or greater to the nearest whole and tenth of a NM (e.g., 2.1 NM FROM DER). Specify distances less than 1 NM in feet (e.g., 1280 FT FROM DER).

Examples:

NOTE: RWY 35, TREES 1280 FT FROM DER, 120 FT LEFT OF CENTERLINE, 50 FT AGL/1527 FT MSL.

NOTE: RWY 35, BUILDING 2.1 NM FROM DER, 160 FT LEFT OF CENTERLINE, 350 FT AGL/1927 FT MSL.

NOTE: RWY 17, MULTIPLE BUILDINGS 500 FT FROM DER, 350 FT RIGHT OF CENTERLINE, 50 FT AGL/1,107 FT MSL. ANTENNA 6000 FT FROM DER, 1235 FT LEFT OF CENTERLINE, 200 FT AGL/1257 FT MSL.

NOTE: RWY 27, MULTIPLE TREES AND ANTENNAS BEGINNING 500 FT FROM DER, 350 FT RIGHT OF CENTERLINE, UP TO 110 FT AGL/1307 FT MSL.

c. These obstacle NOTES must be published by charting agents.

7. Controlling Obstacles.

a. **Document the controlling obstacle(s)** found as a result of applying table 1, Situation 3 and/or Situation 4.

Note: For all DPs, the controlling obstacle is that obstacle which, having penetrated the 40:1 Obstacle Clearance Surface (OCS) causes the most adverse climb gradient and/or ceiling and/or visibility to be published.

b. **Use the following format** to list the runway affected, elevation and type of obstacle, the coordinates to the nearest 0.01 second, and if applicable, OCS height above DER elevation; e.g., **“RWY 32: 2049 FT MSL TERRAIN 341548.01N/0862101.05W.”**

c. **Document the obstacle(s)** that mandated development of a specific RNAV ODP route. These obstacles are not considered the “controlling obstacles” because they are not a factor to the specified route being flown. This information will not be charted on the procedure. Document these obstacles as follows:

“OBSTACLES MANDATING ODP ROUTE DEVELOPMENT: RWY 36 - 2049 FT MSL ANTENNA 341658.01N/ 0863108.05W.”

8. **Lost Communications Procedures.** ATC is responsible for determining the need and content of lost communications instructions. Leave blank when procedures are the same as in 14 CFR Part 91.185 (standard).

9. **Additional Flight Data.** List any additional charting instructions, items essential to clarify charting or information a specialist has determined needs charting as other than a NOTE. Examples of data may include:

a. **Terrain features, airports, military operating areas (MOA), holding patterns, or takeoff and departure obstacles;** e.g., **CHART: _____ MOA; CHART: HOLDING PATTERN AT ICT VORTAC, HOLD NE, RT, 222.03 INBOUND** (Include Leg Length for RNAV or DME Holding, when applicable and speed, if other than standard). Ensure that the accompanying Form 8260-2 contains the appropriate documentation for holding patterns supporting the departure procedure.

b. **Document the MEA/MOCA for the segment** between the IF and Basic DP fix on RNAV Radar departure procedures as follows: **CHART: MEA/MOCA FROM (RNAV IF) TO (BASIC DP FIX), (Altitude).**

c. **Place the reference (departure airport) magnetic variation** of record used to develop the procedure in this section. Include the point of reference and the epoch year. Example: **“REFERENCE MAG VAR: KFCR 2W EPOCH YR: 2000”**

d. **DME Assessment (Enter one of the following):**

- (1) “DME/DME ASSESSMENT: SAT (RNP 1.0 OR 2.0 AS APPROPRIATE).”
Indicates a successful assessment to the RNP value specified.
- (2) “DME/DME ASSESSMENT: UNSAT (RNP 1.0), SAT (RNP 2.0).” Indicates an unsuccessful assessment to RNP 1.0, but returned a successful assessment to RNP 2.0.
- (3) “DME/DME ASSESSMENT: UNSAT.” Indicates an unsuccessful assessment to RNP 2.0.
- (4) “DME/DME Assessment: NOT CONDUCTED.”

Note 1: If the DME/DME assessment indicates “UNSAT” or “NOT CONDUCTED,” the note “GPS Required” must be entered in the Procedural Data Notes/Takeoff Minimums section.

Note 2: The DME/DME assessment process is covered in separate guidance.

e. **Use this section to describe the** Pilot Navigation Area (PNA) for RNAV Radar departures. The description will be in the following manner:

PILOT NAVIGATION AREA:

7 NM ARC CENTERED ON WAYPT (IF), CW
FROM: POINT A (BEARING 015 DEGREES TO WAYPT)
TO: POINT B (BEARING 105 DEGREES TO WAYPT)
MINIMUM ALTITUDE - 4000

Note: The illustration in figure E-1 is provided as an example of what this text is describing. An illustration may be provided but is not required on the form.

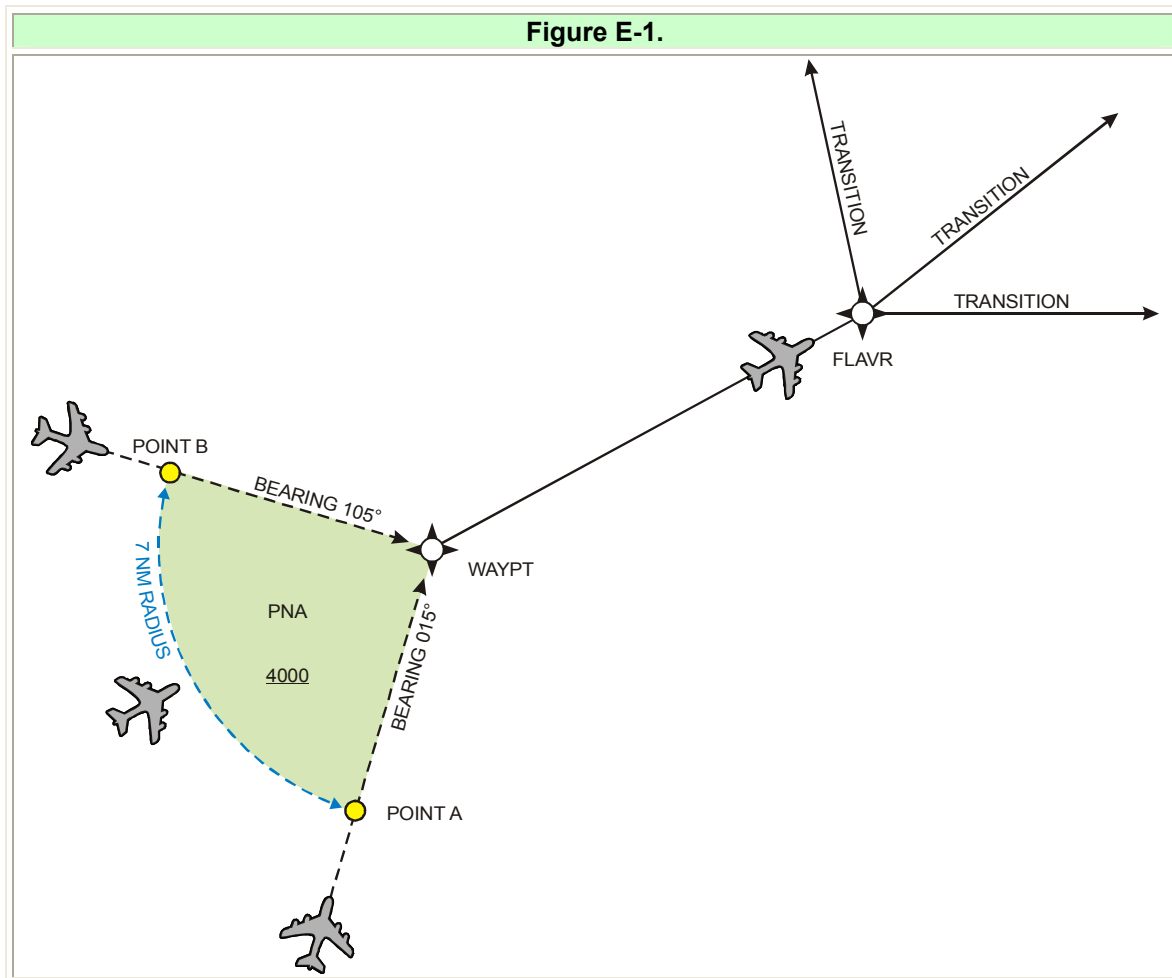

10. Airports Served. Except for RDVAs, RNAV DPs may only serve one airport. List the airport, city, and 2-letter state code served by the departure procedure.

11. Communications. Enter name of radio communications to be charted; e.g., ATIS, CTAF, Clearance Delivery, Departure Control, etc. Specify frequency only if different than what is currently published for the facility, or unique to the procedure.

12. Fixes and/or NAVAIDs. Enter only those fixes and/or NAVAIDs for which charting is requested but are not included in the textual description of the departure or entered in the transition route data.

13. Remarks. List information/data which is NOT to be charted; e.g., administrative data or notes for controller information (requested by ATC). Document when a climb gradient has been established to support RNAV or RNP operational requirements (e.g., RNAV-Pro DME/DME/IRU limitations), etc.

14. Flight Inspected By. Enter the name of the airspace system inspection pilot who conducted the flight inspection, and date.

15. Developed By. Enter the name of the procedure specialist and **AeroNav Services**. This individual must sign in the “developed by” space, and enter the date signed.

16. Approved By. Enter the name of the **AeroNav Services**’ Manager, or his/her delegated representative. This individual must sign in the “approved by” space and enter the date signed. If the procedure is a “Special,” this line will contain the name of and be signed by AFS-400.

17. Coordinated With. Specify the offices/organizations the procedure was coordinated with. Departure procedure coordination must be identical with the approach procedure coordination as outlined in Order 8260.19 (latest edition), chapter 8.

18. Changes. List changes relating to data entries.

19. Reasons. List reasons for changes relating to data entries.

20. Required Effective Date.

a. Enter the effective date as noted in Order 8260.19 (latest edition), chapter 8, except that “Proposed” dates may not be used for graphic DPs. Optimally, submit as “routine.” En route data submission cutoff dates must apply for graphic DPs.

b. If the Form 8260-15B represents a concurrent action, enter “CONCURRENT” followed by the necessary information; e.g., Airport ID, IAP name and amendment number; airspace action, or other event.

Figure E-2.

U.S. DEPARTMENT OF TRANSPORTATION - FEDERAL AVIATION ADMINISTRATION
GRAPHIC DEPARTURE PROCEDURE (DP)

Bearings, headings, courses, tracks, and radials are magnetic. Elevations and altitudes are in feet, MSL. Altitudes are minimum altitudes unless otherwise indicated. Crossings are in feet above airport elevation. Distances are in nautical miles (NM). Visibilities are in statute miles (SM) or feet RVR, unless otherwise indicated. Graphic depiction attached.

DP Name	DP Computer Code	Dated	Effective Date
SHEMP	SHEMP1,SHEMP		
Number	Superseded Number		
ONE	NONE		

Type: RNAV SID

DP ROUTE DESCRIPTION:

TAKEOFF RWY 1: CLIMB ON COURSE 007.52 TO LARRY, THEN ON DEPICTED ROUTE TO SHEMP, THENCE...
TAKEOFF RWY 14L: CLIMB ON COURSE 137.64 TO CROSS CURLY AT OR ABOVE 1000, THEN CLIMBING LEFT TURN DIRECT SHEMP, THENCE...
TAKEOFF RWY 32R: CLIMB ON 317.66 HEADING TO AT OR ABOVE 1000, THEN TURN RIGHT DIRECT TO LARRY, THEN ON DEPICTED ROUTE TO SHEMP, THENCE...

... (TRANSITION), MAINTAIN 5000, EXPECT FILED ALTITUDE 10 MINUTES AFTER DEPARTURE.

TRANSITION ROUTES (GRAPHIC DEPICTION ONLY):

Transition Name	Computer Codes	FIX/NAVAID	To FIX/NAVAID	Course	Distance	MEA	MOCA	Crossing Altitudes/Fixes
Transition From								
FOGART	SHEMP1,FGH	SHEMP	FGH VORTAC	TRACK 087.11	87.24	5000	3700	
JENKO	SHEMP1,JKL	SHEMP	JKL VORTAC	TRACK 098.77	92.51	5000		
LAYMAN	SHEMP1,LMN	SHEMP	LMN VOR/DME	RIGHT TURN TRACK 154.94	47.23	5000	4100	
ROOSTER	SHEMP1,RST	SHEMP	LMN VOR/DME	RIGHT TURN TRACK 154.94	47.23	5000	4100	
			RST VORTAC	TRACK 098.38	39.79	7000	4400	

PROCEDURAL DATA NOTES/TAKEOFF MINIMUMS:

TAKEOFF MINIMUMS: RWY 14R: 19, 32L NA - AIR TRAFFIC. RWY 1, 32R STANDARD. RWY 14L 500-2 1/2 OR STANDARD WITH MINIMUM CLIMB OF 330 FT PER NM TO 1200.
NOTE: DME/DME/RU OR GPS REQUIRED

NOTE: RNAV-1

NOTE: RADAR REQUIRED FOR NON-GPS EQUIPPED AIRCRAFT

TAKEOFF OBSTACLE NOTES:

NOTE: RWY 1, OBSTRUCTION LIGHT 1022 FT FROM DER, 672 FT RIGHT OF CENTERLINE, 73 FT AGL/543 FT MSL.
NOTE: RWY 14L, BUILDING 1.96 NM FROM DER, 575 FT RIGHT OF CENTERLINE, 478 FT AGL/974 FT MSL.
NOTE: RWY 32R, TREES 143 FT LEFT OF DER, 21 FT AGL/498 FT MSL.

CONTROLLING OBSTACLES:

RWY 1: 543 FT MSL OBSTRUCTION LIGHT, 325141.44N/0965102.87W.
RWY 14L: 974 FT MSL BUILDING, 324911.09N/0964638.62W.
RWY 32R: 1049 FT MSL TOWER, 325216.19N/0965523.02W, 498 FT MSL TREES, 325125.20N/0965125.68W.

LOST COMMUNICATIONS PROCEDURES:

U.S. DEPARTMENT of TRANSPORTATION - FEDERAL AVIATION ADMINISTRATION
GRAPHIC DEPARTURE PROCEDURE (DP)

Bearings, headings, courses, tracks, and radials are magnetic. Elevations and altitudes are in feet, MSL. Altitudes are minimum altitudes unless otherwise indicated. Ceilings are in feet above airport elevation. Distances are in nautical miles (NM). Visibilities are in statute miles (SM) or feet RVR unless otherwise indicated. Graphic depiction attached.

DP Name: **SHEMP** Number: **ONE** DP Computer Code: **SHEMP1.SHEMP** Superseded Number: **NONE** Dated: Effective Date:

ADDITIONAL FLIGHT DATA:

REFERENCE MAG VAR: KFCR 2W EPOCH YR: 00
DME/DME ASSESSMENT: UNSAT

AIRPORTS SERVED:

FOUR CLOWNS REGIONAL, VICTORVILLE, TX

COMMUNICATIONS:

ATTIS, CLNC DEL, GND CON, FCR ATCT, ARCON DEP CON

FIXES AND/OR NAVAIDS:

REMARKS:

FLIGHT INSPECTED BY:

Johnathan P. Doe

DEVELOPED BY:

Timothy S. Wisenheimer
(John Q. Public)

APPROVED BY:

David P. Specialist

COORDINATED WITH:

ATA, ALPA, AOPA, NBAA, ARPT MGR, FCR ATCT, ZFW

CHANGES:

REASONS:

REQUIRED EFFECTIVE DATE:

ROUTINE

4/15/2010

FIOG

2/13/2010

AJV-352

6/12/2010

AJV-352

Figure E-3.

U.S. DEPARTMENT OF TRANSPORTATION - FEDERAL AVIATION ADMINISTRATION
GRAPHIC DEPARTURE PROCEDURE (DP)

Bearings, headings, courses, tracks, and radials are magnetic. Elevations and altitudes are in feet, MSL. Altitudes are minimum altitudes unless otherwise indicated. Ceilings are in feet above airport elevation. Distances are in nautical miles (NM). Visibilities are in statute miles (SM) or feet RVR unless otherwise indicated. Graphic depiction attached.

DP Name: **SHEMP** DP Computer Code: **SHEMP2,SHEMP** Superseded Number: **ONE** Dated: **18-Apr-02** Effective Date:

Type: RNAV SID

DP ROUTE DESCRIPTION:

TAKEOFF RWY 1: CLIMB ON COURSE 007.52 TO CROSS LARRY AT OR ABOVE 2000, THEN ON TRACK 038.92 TO CROSS MOEHH AT OR ABOVE 3000, THEN ON TRACK 091.64 TO CROSS SHEMP AT OR ABOVE 5000, AT OR BELOW 8000, THENCE...

TAKEOFF RWY 14L: CLIMB ON COURSE 137.64 TO CROSS CURLY AT OR ABOVE 1000, THEN TURN LEFT ON TRACK 059.62 TO CROSS SHEMP AT OR ABOVE 5000, AT OR BELOW 8000, THENCE...

TAKEOFF RWY 32R: CLIMB ON HEADING 317.66 TO AT OR ABOVE 1000, THEN TURN RIGHT DIRECT TO CROSS LARRY AT OR ABOVE 2000, THEN ON TRACK 038.92 TO CROSS MOEHH AT OR ABOVE 3000, THEN ON TRACK 091.64 TO CROSS SHEMP AT OR ABOVE 5000, AT OR BELOW 8000, THENCE...

... (TRANSITION), MAINTAIN 5000, EXPECT FILED ALTITUDE 10 MINUTES AFTER DEPARTURE.

TRANSITION ROUTES (GRAPHIC DEPICTION ONLY):

Transition Name	Computer Codes	From	To	Course	Distance	MEA	MOCA	Crossing Altitudes/Fixes
FOGART	SHEMP2,FGH	SHEMP	FGH VORTAC	TRACK 095.11	87.24	5000	3700	
JENKO	SHEMP2,JKL	SHEMP	JKL VORTAC	TRACK 096.77	92.51	5000		
OPAKE	SHEMP2,OPQ	SHEMP	OPQ	LEFT TURN	52.21	4000	3300	
ROOSTER	SHEMP2,RST	SHEMP	VOR/DME	TRACK 003.19				
			RST VORTAC	TRACK 096.38	39.79	7000	4900	

PROCEDURAL DATA NOTES TAKEOFF MINIMUMS:

TAKEOFF MINIMUMS: RWY 14R, 19, 32L NA - AIR TRAFFIC. RWY 1, 32R STANDARD. RWY 14L 500-2 1/2 OR STANDARD WITH MINIMUM CLIMB OF 330 FT PER NM TO 1200.
NOTE: GPS REQUIRED.
NOTE: RNAV-1

TAKEOFF OBSTACLE NOTES:

NOTE: RWY 1, OBSTRUCTION LIGHT 1022 FT FROM DER, 672 FT RIGHT OF CENTERLINE, 73 FT AGL/543 FT
NOTE: RWY 14L, BUILDING 1.96 NM FROM DER, 575 FT RIGHT OF CENTERLINE, 478 FT AGL/974 FT MSL.
NOTE: RWY 32R, TREES 143 FT LEFT OF DER, 21 FT AGL/498 FT MSL.

CONTROLLING OBSTACLES:

RWY 1: 543 FT MSL OBSTRUCTION LIGHT, 325141.44NM0965102.87W.
RWY 14L: 974 FT MSL BUILDING, 324911.09NM0964838.62W.
RWY 32R: 1049 FT MSL TOWER, 325216.19NM0965523.02W, 498 FT MSL TREES, 325125.20NM0965125.68W.

LOST COMMUNICATIONS PROCEDURES:

U.S. DEPARTMENT OF TRANSPORTATION - FEDERAL AVIATION ADMINISTRATION
GRAPHIC DEPARTURE PROCEDURE (DP)

Bearings, headings, courses, tracks, and radials are magnetic. Elevations and altitudes are in feet, MSL. Altitudes are minimum altitudes unless otherwise indicated. Ceilings are in feet above airport elevation. Distances are in nautical miles (NM). Visibilities are in statute miles (SM) or feet RVR unless otherwise indicated. Graphic depiction attached.

DP Name: SHEMP
Number: TWO
DP Computer Code: SHEMP2.SHEMP
Superseded Number: ONE
Dated: 18-APR-02
Effective Date:

ADDITIONAL FLIGHT DATA:

REFERENCE MAG-VAR: KFCR 2W EPOCH YR: 00
DME/DME ASSESSMENT: UNSAT

AIRPORTS SERVED:

FOUR CLOWNS REGIONAL, VICTORVILLE, TX

COMMUNICATIONS:

ATIS, CLNC DEL, GND CON, FCR ATCT, ARCON DEP CON

FIXES AND/OR NAVAIDS:

REMARKS:

FLIGHT INSPECTED BY:

Jonathan P. Doe

FIQG 4/15/2011

REQUIRED EFFECTIVE DATE:

ROUTINE

DEVELOPED BY:

Timothy S. Wisenheimer
(John Q. Public)

AJV-352 2/13/2011

APPROVED BY:

David P. Specialist

AJV-352 6/12/2011

COORDINATED WITH:

ATA, ALPA, APA, AOPA, NBAA, ARPT MGR, FCR ATCT, ZFW

CHANGES:

1. ADDED OPQ TRANSITION.
2. REMOVED LMN VOR/DME FROM RST TRANSITION
3. RELOCATED MOEHH
4. DELETED AUTHORIZATION TO USE DME/DME/IRU
5. DELETED NOTE: RADAR REQUIRED FOR NON-GPS EQUIPPED AIRCRAFT

REASONS:

- 1-3. RAPT REQUEST.
- 4-5. ABILITY TO USE DME/DME/IRU NO LONGER AVAILABLE

Figure E-4.

U.S. DEPARTMENT OF TRANSPORTATION - FEDERAL AVIATION ADMINISTRATION
GRAPHIC DEPARTURE PROCEDURE (DP)

Bearings, headings, courses, tracks, and radials are magnetic. Elevations and altitudes are in feet, MSL. Altitudes are minimum altitudes unless otherwise indicated. Ceilings are in feet above airport elevation. Distances are in nautical miles (NM). Visibilities are in statute miles (SM) or feet RVR unless otherwise indicated. Graphic depiction attached.

DP Name	DP Computer Code	Superseded Number	Dated	Effective Date
ARKES	ARKEST,ARKES	NONE		

Type: RNAV SID

DP ROUTE DESCRIPTION:

TAKEOFF RWY 9L: CLIMB HEADING 093.36 TO 520, THEN DIRECT JUMAR, THEN LEFT TURN ON TRACK 351.15 TO HAPOR, THEN ON DEPICTED ROUTE, THENCE...
 TAKEOFF RWY 9R: CLIMB HEADING 093.36 TO 520, THEN LEFT TURN DIRECT JUMAR, THEN LEFT TURN ON TRACK 351.15 TO HAPOR, THEN ON DEPICTED ROUTE, THENCE...
 TAKEOFF RWY 13: CLIMB HEADING 138.36 TO 520, THEN LEFT TURN DIRECT JUMAR, THEN LEFT TURN ON TRACK 351.15 TO HAPOR, THEN ON DEPICTED ROUTE, THENCE...
 TAKEOFF RWY 27L: CLIMB HEADING 273.39 TO 520, THEN RIGHT TURN DIRECT NOVAE, THEN ON DEPICTED ROUTE, THENCE...
 TAKEOFF RWY 27R: CLIMB HEADING 273.38 TO 520, THEN DIRECT NOVAE, THEN ON DEPICTED ROUTE, THENCE...
 TAKEOFF RWY 31: CLIMB HEADING 318.37 TO 520, THEN DIRECT NOVAE, THEN ON DEPICTED ROUTE, THENCE...

... MAINTAIN 3000 OR AS ASSIGNED BY ATC. EXPECT CLEARANCE TO FILED ALTITUDE 10 MINUTES AFTER DEPARTURE.

TRANSITION ROUTES (GRAPHIC DEPICTION ONLY):

Transition Name	Computer Codes	From	To	Course	Distance	MEA	MOCA	Crossing Altitudes/Fixes
		FIX/NAVAID	FIX/NAVAID					

PROCEDURAL DATA NOTES/TAKEOFF MINIMUMS:

TAKEOFF MINIMUMS: RWY 9L, 9R STANDARD. RWY 13, 27L, 27R, 31 STANDARD WITH CLIMB OF 500 FT PER NM TO 520
 NOTE: DME/DME/RUR OR GPS REQUIRED
 NOTE: RNAV-1
 NOTE: RADAR REQUIRED FOR NON-GPS EQUIPPED AIRCRAFT
 NOTE: TURBOJET AIRCRAFT ACCELERATE TO 250 KIAS (ATC) WITHIN 7 NM OF DEPARTURE. IF UNABLE, ADVISE ATC.

TAKEOFF OBSTACLE NOTES:

NOTE: RWY 9L, RAILROAD, LIGHT POLE, AND ANTENNA ON BUILDING BEGINNING 469' FT FROM DER, 379' FT LEFT OF CENTERLINE, UP TO 43 FT AGL/47 FT MSL. LIGHT POLE 1332 FT FROM DER, 634 FT RIGHT OF CENTERLINE, 42 FT AGL/46 FT MSL. TREE 1977 FT FROM DER, 272 FT RIGHT OF CENTERLINE, 55 FT AGL/59 FT MSL.
 NOTE: RWY 9R, LIGHT POLE 545 FT FROM DER, 335 FT LEFT OF CENTERLINE, 27 FT AGL/41 FT MSL. TREE 783 FT FROM DER, 396 FT LEFT OF CENTERLINE, 30 FT AGL/44 FT MSL. ANTENNA ON BUILDING, FENCE, LIGHT POLE, AND MULTIPLE TREES BEGINNING 254 FT FROM DER, 133 FT RIGHT OF CENTERLINE, UP TO 56 FT AGL/70 FT MSL.
 NOTE: RWY 13, MULTIPLE TREES BEGINNING 844 FT FROM DER, 208 FT LEFT OF CENTERLINE, UP TO 76 FT AGL/80 FT MSL. ANTENNA ON BUILDING 534 FT FROM DER, 431 FT LEFT OF CENTERLINE, 11 FT AGL/20 FT MSL. POLE 910 FT FROM DER, ON CENTERLINE, 30 FT AGL/39 FT MSL. RAILROAD CROSSING ARM 1104 FT FROM DER, 14 FT RIGHT OF CENTERLINE, 42 FT AGL/56 FT MSL. MULTIPLE TREES AND LIGHT POLES BEGINNING 583 FT FROM DER, 53 FT RIGHT OF CENTERLINE, UP TO 81 FT AGL/85 FT MSL.
 NOTE: RWY 27L, FENCE 154 FT FROM DER, 120 FT LEFT OF CENTERLINE, 5 FT AGL/13 FT MSL. ROAD 272 FT FROM DER, 80 FT LEFT OF CENTERLINE, 11 FT AGL/20 FT MSL. SIGN, MULTIPLE BUILDINGS, POLES, AND TREES BEGINNING 622 FT FROM DER, 227 FT LEFT OF CENTERLINE, UP TO 97 FT AGL/106 FT MSL. BUSH, MULTIPLE LIGHT POLES, TREES, AND TOWER'S BEGINNING 221 FT FROM DER, 41 FT RIGHT OF CENTERLINE, UP TO 105 FT AGL/114 FT MSL.
 NOTE: RWY 27R, ANTENNA ON BUILDING, ROAD, RAILROAD, AND SIGN BEGINNING 262 FT FROM DER, 6 FT LEFT OF CENTERLINE, UP TO 37 FT AGL/46 FT MSL. MULTIPLE TREES BEGINNING 1206 FT FROM DER, 279 FT LEFT OF CENTERLINE, UP TO 93 FT AGL/97 FT MSL. ROAD 584 FT FROM DER, 557 FT RIGHT OF CENTERLINE, 24 FT AGL/33 FT MSL.
 NOTE: RWY 31, ROD ON TOWER 298 FT FROM DER, 382 FT LEFT OF CENTERLINE, 14 FT AGL/23 FT MSL. TREE 1332 FT FROM DER, 458 FT LEFT OF CENTERLINE, 34 FT AGL/43 FT MSL. ROAD 3384 FT FROM DER, 711 FT LEFT OF CENTERLINE, 84 FT AGL/84 FT MSL. MULTIPLE TREES AND POLES BEGINNING 1180 FT FROM DER, 405 FT RIGHT OF

U.S. DEPARTMENT OF TRANSPORTATION - FEDERAL AVIATION ADMINISTRATION
GRAPHIC DEPARTURE PROCEDURE (DP)

Bearings, headings, courses, tracks, and radials are magnetic. Elevations and altitudes are in feet MSL. Altitudes are minimum altitudes unless otherwise indicated. Ceilings are in feet above airport elevation. Distances are in nautical miles (NM). Distances are in statute miles (SM) or feet RVR unless otherwise indicated. Graphic depiction attached.

DP Name: ARKES
Number: ONE
DP Computer Code: ARKES1-ARKES
Superseded Number: NONE
Dated: Effective Date

CONTROLLING OBSTACLES:

RWY 9L: 352 FT MSL STACKS 260509.00N/0800730.00W.
RWY 13: 1049 FT MSL TOWER 255935.28N/0801026.00W.
RWY 27L: 1049 FT MSL TOWER 255935.28N/0801026.00W.
RWY 27R: 1049 FT MSL TOWER 255935.28N/0801026.00W.

LOST COMMUNICATIONS PROCEDURES:

ADDITIONAL FLIGHT DATA:

REFERENCE MAG VAR: KFLL 3W EPOCH YR: 85. DME/DME/IRU ASSESSMENT: SAT (RNP 2.0).

AIRPORTS SERVED:

FORT LAUDERDALE/HOLLYWOOD INTL FORT LAUDERDALE, FL

COMMUNICATIONS:

ATIS, CLNC DEL, GND CON, FLL ATCT, DEP CON 126.05

FIXES AND/OR NAVAID'S:

REMARKS:

RWY 13, 27L, 27R, 31 CLIMB GRADIENT OF 500 FEET PER NM DRIVEN BY AC 90-100 OPERATIONAL REQUIREMENT TO ENGAGE LNAV NO LATER THAN 500 FEET ABOVE AIRPORT ELEVATION.

FLIGHT INSPECTED BY:

Johnathan P. Doe

FOG

2/13/2011

REQUIRED EFFECTIVE DATE:

ROUTINE

DEVELOPED BY:

Timothy S. Wisenheimer
(John Q. Public)

AJV-352

2/13/2011

APPROVED BY:

David P. Specialist

AJV-352

2/13/2011

U.S. DEPARTMENT OF TRANSPORTATION - FEDERAL AVIATION ADMINISTRATION
GRAPHIC DEPARTURE PROCEDURE (DP)

Bearings, headings, courses, tracks, and radials are magnetic. Elevations and altitudes are in feet, MSL. Altitudes are minimum altitudes unless otherwise indicated. Ceilings are in feet above airport elevation. Distances are in nautical miles (NM). Vicinities are in statute miles (SM) or feet RVR unless otherwise indicated. Graphic depiction attached.

DP Name: ARKES Number: ONE DP Computer Code: ARKEST,ARKES Superseded Number: NONE Dated: Effective Date:

COORDINATED WITH:
ATA, ALPA, APA, AOPA, NBAA, ZMA, MIA APP CON

CHANGES:

REASONS:

THIS PAGE INTENTIONALLY LEFT BLANK

Figure E-5.

U.S. DEPARTMENT OF TRANSPORTATION - FEDERAL AVIATION ADMINISTRATION
GRAPHIC DEPARTURE PROCEDURE (DP)

Bearings, headings, courses, tracks, and radials are magnetic. Elevations and altitudes are in feet, MSL. Altitudes are minimum altitudes unless otherwise indicated. Crossings are in feet above airport elevation. Distances are in nautical miles (NM). Visibilities are in statute miles (SM) or feet EVR unless otherwise indicated. Graphic depiction attached.

DP Name: **FLAVR** Type: **RNAV** SID: **ONE** Effective Date: **ONE**
 DP Computer Code: **FLAVR1.FLAVR** Superseded Number: **ONE** Dated: **ONE**

DP ROUTE DESCRIPTION:

TAKEOFF RWY 1, 14L, 32R; CLIMB ON ASSIGNED HEADING FOR RADAR VECTORS TO WAYPT, THEN ON TRACK 075.33 TO FLAVR, THENCE...

(TRANSITION), MAINTAIN 5000, EXPECT FILED ALTITUDE 10 MINUTES AFTER DEPARTURE.

TRANSITION ROUTES (GRAPHIC DEPICTION ONLY):

Transition Name	Computer Codes	From	To	Fix/NAVAID	Course	Distance	MEA	MOCA	Crossing Altitudes/Fixes
FOGART	FLAVR1.FGH	FLAVR	FGH	VORTAC	TRACK 085.11	84.74	5000	3700	
JENKO	FLAVR1.JKL	FLAVR	JKL	VORTAC	TRACK 095.06	88.8	5000		
OPAKE	FLAVR1.OPQ	FLAVR	OPQ	VOR/DME	LEFT TURN TRACK 333.87	55.23	4000	3300	
ROOSTER	FLAVR1.RST	FLAVR	RST	VORTAC	TRACK 129.92	72.85	7000	4900	

PROCEDURAL DATA NOTES/TAKEOFF MINIMUMS:

TAKEOFF MINIMUMS: RWY 14R, 19, 32L: NA - AIR TRAFFIC. RWY 1, 32R: STANDARD. RWY 14L: 500-2-1/2 OR STANDARD WITH MINIMUM CLIMB OF 330 FT PER NM TO 1200.

NOTE: DME/DME/RU OR GPS REQUIRED.

NOTE: RNAV-1

NOTE: RADAR REQUIRED

TAKEOFF OBSTACLE NOTES:

NOTE: RWY 1, OBSTRUCTION LIGHT 1022 FT FROM DER, 972 FT RIGHT OF CENTERLINE, 73 FT AGL/543 FT MSL.

NOTE: RWY 14L, BUILDING 1.96 NM FROM DER, 575 FT RIGHT OF CENTERLINE, 478 FT AGL/874 FT MSL.

NOTE: RWY 32R, TREES 143 FT LEFT OF DER, 21 FT AGL/498 FT MSL.

CONTROLLING OBSTACLES:

RWY 1, 543 FT MSL OBSTRUCTION LIGHT, 325141.44N/0965102.87W

RWY 14L, 974 FT MSL BUILDING, 324911.09N/0964838.62W

RWY 32R, 1049 FT MSL TOWER, 325216.19N/0965523.02W, 486 FT MSL TREES, 325125.20N/0965125.68W.

LOST COMMUNICATIONS PROCEDURES:

U.S. DEPARTMENT OF TRANSPORTATION - FEDERAL AVIATION ADMINISTRATION
GRAPHIC DEPARTURE PROCEDURE (DP)

Bearings, headings, courses, tracks, and radials are magnetic. Elevations and altitudes are in feet, MSL. Altitudes are minimum altitudes unless otherwise indicated. Ceilings are in feet above airport elevation. Distances are in nautical miles (NM). Visibilities are in statute miles (SM) or feet EVR unless otherwise indicated. Graphic depiction attached.

DP Name: FLAVR ONE FLAVR1.FLAVR Superseded Number Dated Effective Date

ADDITIONAL FLIGHT DATA:
REFERENCE MAG VAR: KFOR 2W EPOCH YR: 00
DME/DME ASSESSMENT: SAT
CHART: MEA/MOCA FROM WAYPT TO FLAVR, 4000/3000

AIRPORTS SERVED:
FOUR CLOWNS REGIONAL, VICTORVILLE, TX

COMMUNICATIONS:
ATIS, CLNC DEL, GND CON, FCR ATCT, ARCON DEP CON

FIXES AND/OR NAV AIDS:

REMARKS:

FLIGHT INSPECTED BY:
Johnathan P. Doe FIOG 4/15/2011 **REQUIRED EFFECTIVE DATE:**
09/23/2011

DEVELOPED BY:
Timothy S. Wisenheimer AJV-352 2/13/2011

APPROVED BY:
David P. Specialist AJV-352 6/12/2011

COORDINATED WITH:
ATA, ALPA, APA, ACPA, NBAA, ARPT MGR, FCR ATCT, ZFW

CHANGES:

REASONS:

Appendix E. Section 2. Instructions for Completing FAA Form 8260-15C, Departure (Data Record) and Sample Forms

1. Basic instructions for completing Form 8260-15C. Detailed instructions are contained in appendix E, paragraphs 2 through 5. Enter a dash (e.g., “-“) in the FO/FB, Leg Type, TC (True Course), and Distance columns when they are intentionally left blank.

a. Fix/NAVAID. Enter the name of the fix/NAVAID in one of the following formats: (5-letter pronounceable name; (NAVAID) 3-letter facility ID and type (e.g., ABC VORTAC).

b. Lat/Long. Enter the latitude and longitude, separated by a “slant(/)” to the nearest hundredth of a second.

c. C (Chart). Enter a Y (yes) if a fix is to be charted. Enter an N (no) if a fix does not require charting. Any fix where a change in altitude, course, or speed, including WPs where turns or transitions begin and end, require charting.

d. FO/FB. Enter the FO (Fly-over) or FB (Fly-by) as appropriate to indicate desired use. FB is the normal designation. Determination is based on operational or obstacle requirements.

e. Leg Type. Enter the two-letter ARINC-24 code for leg-type; e.g., IF, TF, RF, etc.

f. TC. Enter the true course (TC) to the nearest hundredth of a degree. The charting agency will apply magnetic variation, if necessary, and round for publication.

g. Dist. Enter the distance to the nearest hundredth of a NM. The charting agency will round for publication.

h. Altitude. Enter the minimum, mandatory, or maximum altitude in 100-ft increments (or Flight Levels in 1000-ft increments) and label each altitude/flight level as “at/above,” “at,” or “at/below.” Enter “block altitudes” with a “B” between the altitude values; e.g., 5000B8000.

i. Speed. Enter the minimum, mandatory, or maximum airspeed(s) in KIAS. Optionally, the airspeed may be entered as ground speed (GS). Label airspeed restrictions as “at/above,” “at,” or “at/below,” as appropriate. Following the numerical value, add “K” for KIAS, or “G” for ground speed. Enter restrictions only where necessary for procedural containment, or for traffic flow requirements.

j. Remarks. Enter any pertinent information that would clarify a data entry; e.g., airspeed restriction for turn radius. Additionally, such items as CG restrictions, displaced threshold information, transition computer code, etc, are also placed in this column. (Enter a change bar to indicate removal of text at the end of this paragraph).

2. The departure routing from each authorized runway to the DP fix (i.e., the DP termination fix) is documented first, followed by the routing from the DP fix to each transition fix as appropriate.

3. Departure Routing to DP Fix (see examples). The initial departure routing represents the most complex portion of documenting the RNAV or RNP DP. The first three lines of the 8260-15C are typically the most problematic, largely due to the variables associated with permissible leg types and waypoint sequencing. The following line-by-line explanation used in conjunction with guidance in appendix A, paragraph 5b, outlines the departure sequence element (i.e., from AER to DP fix) beginning at the AER*, with each succeeding line representing a permissible option until reaching the DP fix. Fix/Navaid, Lat/Long, “C” (chart), FO/FB, Leg Type, TC (True Course), and Distance columns are required entries except as noted. Altitude and Speed columns enter restrictions associated with the Fix/NAVAID column as appropriate.

***Note:** WP placement is computed from DER as outlined in Order 8260.44 (latest edition); AER is a required coding element used for course/heading and distance computations.

4. For each authorized runway:

a. First line (of each element):

- (1) In the Fix/NAVAID column, enter the AER. Example: “RW14L (AER).”
- (2) In the Lat/Long column, enter the AER lat/long. If the runway threshold is displaced, enter the displaced AER lat/long and note the amount of displacement in Remarks column. Example: “RW 14L (AER)*, 325117.19N/0965114.05W*, *DISPL THLD (1273 FT).”
- (3) In the “C” column, enter “N.”
- (4) Remaining columns, leave blank.

Note: For procedures that are strictly Radar Vectors to RNAV, an AER entry is not necessary (i.e., the first entry will be an IF). For procedures that incorporate Radar Vectors to RNAV for one or more runways on the same chart that contains an RNAV route departure off of other runways, the runway(s) that use Radar Vectors to RNAV will require an “AER” entry prior to defining the IF.

b. Second line options:

- (1) CF leg from AER to FB/FO: **True Course and Distance columns**, enter true course/distance from AER to the next fix (see example SHEMP ONE, RW01).
- (2) DF leg from AER to FB/FO: **True Course column**, leave blank. **Distance column**, enter distance from AER to the next fix (see example SHEMP TWO, RW01).
- (3) VI to CF leg (See third line options for required CF entries): **Fix/NAVAID column**, leave blank. **Lat/Long column**, enter the computed lat/long of the VI/CF intersect point. **C columns**, leave blank. **True Course column**, enter the true heading to be flown as

computed from AER to VI/CF intersect point. **Distance column**, enter distance from AER to VI/CF intersect point. **Speed and Altitude columns**: Leave blank.

(4) VA to DF leg (See third line options for required DF entries): **Fix/NAVAID column**, Enter the climb-to MSL altitude. **Lat/Long, C, and FO/FB columns**, leave blank. **True Course column**, enter the true azimuth of the takeoff runway. **Distance, Altitude, and Speed columns**, leave blank. (See example for SHEMP TWO, RW32R.)

c. Third line options (if required; third line required for VA combinations):

(1) DF leg (preceded by FO WP): **True Course column**, leave blank. **Distance column**, enter the distance between the plotted positions of fixes. **Remarks column**, specify turn direction as either “Left/Right Turn” when required (see example SHEMP ONE, RW14L).

(2) TF leg: **True Course and Distance columns**, enter the true course and distance between the plotted position of fixes. **Remarks Column**, specify turn direction as described above only if course change exceeds 90 degrees.

(3) CF leg (VI/CF combination): **True Course and Distance columns**, enter the true course and distance from the VI/CF intersect point to the next fix (CF termination fix). **Remarks column**, specify turn direction as described above only if course change exceeds 90 degrees (see example SHEMP ONE, RW32R).

(4) DF leg (VA/DF combination): **True Course and Distance columns**, leave blank. **Remarks column**, specify turn direction as either “Left/Right Turn” when required (see example SHEMP TWO, RW32R).

d. Fourth and subsequent lines (DF or TF only): Same as third line (1) & (2) entries.

e. The DP routing concludes with the DP fix data entered on the last line of each routing element. Repeat this process until all authorized runways have been entered.

5. Transition Routing (see examples).

a. For each transition:

(1) First line (of each element):

(a) Fix/NAVAID and Lat/Long columns: Enter the DP fix name and lat/long.

(b) “C” (chart) column: Enter "Y".

(c) FO/FB column: Leave blank.

(d) Leg Type column: Enter “IF.”

(e) True Course, Distance, Altitude, and Speed columns: Leave blank.

(f) Remarks column: Enter the transition computer code.

(2) Second and subsequent lines (DF or TF only): Same as departure routing element third line (1) and (2) entries. Enter the transition fix data on the last line of the transition routing element.

Figure E-6.

DEPARTURE (DATA RECORD)

DP Name	Number	DP Computer Code	Superseded Number	Dated	Effective Date				
SHEMP	ONE	SHEMP1.SHEMP	NONE						
FIX/NAVAID	LAT/LONG	C	FO/FE	LEG	TC	DIST	ALTITUDE	SPEED	REMARKS
RW01 (AER)	325030.65N/0965118.52W	N	-	-	-	-	-	-	-
LARRY	325615.86N/0965038.96W	Y	FB	CF	005.52	5.77			
MOEHH	330002.41N/0964701.80W	Y	FB	TF	038.92	4.84			
SHEMP	325932.61N/0962728.24W	Y	FB	TF	091.64	16.46			
RWY14L (AER)*	325117.19N/0965114.05W*	N	-	-	-	-	-	-	*DISPL THLD (1273 FT)
CURLY	324935.48N/0964916.24W	Y	FO	CF	135.64	2.37	AT/ABOVE 1000		CG 330 FT PER NIM TO 1200
SHEMP	325932.61N/0962728.24W	Y	FB	DF		20.87			LEFT TURN
RW32R (AER)	325031.35N/0965020.95W	N	-	-	-	-	-	-	-
1000 MSL	-	-	-	VA	315.66	3.84			
LARRY	325615.86N/0965038.96W	Y	FO	DF					RIGHT TURN
MOEHH	330002.41N/0964701.80W	Y	FO	TF	038.92	4.84			
SHEMP	325932.61N/0962728.24W	Y	FO	TF	091.64	16.46			
SHEMP	325932.61N/0962728.24W	Y	-	IF	-	-	-	-	SHEMP1.FGH
FGH VORTAC	333543.94N/0945243.79W	Y	FB	TF	065.11	87.24			
SHEMP	325932.61N/0962728.24W	Y	-	IF	-	-	-	-	SHEMP1.JKL
JKL VORTAC	324749.41N/0943828.97W	Y	FB	TF	096.77	92.52			
SHEMP	325932.61N/0962728.24W	Y	-	IF	-	-	-	-	SHEMP1.LMN
LMN VOR/DME	321721.40N/0960207.48W	Y	FB	TF	152.94	47.23			
SHEMP	325932.61N/0962728.24W	Y	-	IF	-	-	-	-	SHEMP1.RST
LMN VOR/DME	321721.40N/0960207.48W	Y	FB	TF	152.94	47.23			
RST VORTAC	321246.96N/0951530.88W	Y	FB	TF	096.38	39.79			

THIS PAGE INTENTIONALLY LEFT BLANK

Figure E-7.

DEPARTURE (DATA RECORD)

DP Name	Number	DP Computer Code	Superseded Number	Dated	Effective Date				
SHEMP	TWO	SHEMP2.SHEMP	ONE	18 Apr 02					
FIX/NAVAID	LAT/LONG	C	FO/FB	TYPE	TC	DIST (NM)	ALTITUDE	SPEED	REMARKS
RW01 (AER)	325030.65N/0965118.52W	N	-	-	-	-	-	-	-
LARRY	325615.86N/0965038.96W	Y	FO	DF	-	-	AT/ABOVE 2000	-	-
MOEHH	330205.91N/0964502.64W	Y	FO	TF	038.97	7.49	AT/ABOVE 3000	AT/BELOW 220K	-
SHEMP	325932.61N/0962728.24W	Y	FO	TF	099.71	15.00	500088000	-	-
RWY14L (AER)*	325117.19N/0965114.05W	N	-	-	-	-	-	-	*DISPL THLD(1273 FT)
CURLY	324905.36N/0964841.41W	Y	FB	DF	-	3.07	AT/ABOVE 1000	-	CG 330 FT PER NM TO 1200
SHEMP	325932.61N/0962728.24W	Y	FO	TF	059.62	20.69	500088000	-	-
RW32R (AER)	325031.35N/0965020.95W	N	-	-	-	-	-	-	-
1000.MSL	-	-	-	VA	315.66	-	AT/ABOVE 1000	-	-
LARRY	325615.86N/0965038.96W	Y	FO	DF	-	-	AT/ABOVE 2000	-	RIGHT TURN
MOEHH	330205.91N/0964502.64W	Y	FO	TF	038.97	7.49	AT/ABOVE 3000	AT/BELOW 220K	-
SHEMP	325932.61N/0962728.24W	Y	FO	TF	099.71	15.00	500088000	-	-
SHEMP	325932.61N/0962728.24W	Y	-	IF	-	-	-	-	SHEMP2.FGH
FGH VORTAC	333543.94N/0945243.79W	Y	FB	TF	065.11	87.24	-	-	RIGHT TURN
SHEMP	325932.61N/0962728.24W	Y	-	IF	-	-	-	-	SHEMP2.JKL
JKL VORTAC	324749.41N/0943828.97W	Y	FB	TF	096.77	92.51	-	-	RIGHT TURN
SHEMP	325932.61N/0962728.24W	Y	-	IF	-	-	-	-	SHEMP2.OPQ
OPQ VOR/DME	334641.06N/0965429.57W	Y	FB	TF	003.19	52.21	-	-	LEFT TURN
SHEMP	325932.61N/0962728.24W	Y	-	IF	-	-	-	-	SHEMP2.RST
RST VORTAC	321246.96N/0951530.88W	Y	FB	TF	127.19	76.63	-	-	RIGHT TURN

THIS PAGE INTENTIONALLY LEFT BLANK

Figure E-8.

DEPARTURE (DATA RECORD)

DP Name	Number	DP Computer Code	Superseded Number	Dated	Effective Date
ARKES	ONE	ARKES1-ARKES	NONE		
FIXNAVAID					
RW09L (AER)*	260436.98N/0800953.20W	N	-	-	*DISPL THLD (577 FT)
520 MSL	-	-	-	080.36	-
JUN1AR	260431.29N/0795501.17W	Y	FB	DF	-
HAFOR	261243.07N/0795855.56W	Y	FB	TF	348.15 8.35
SECOR	261427.18N/0801120.40W	Y	FB	TF	277.66 13.08
ATONE	262312.14N/0802123.68W	Y	FB	TF	314.03 12.56
ARKES	263437.73N/0802503.60W	Y	FB	TF	343.91 11.86
RW09R (AER)*	260357.49N/0800933.63W	N	-	-	*DISPL THLD (320 FT)
520 MSL	-	-	-	080.38	-
JUN1AR	260431.29N/0795501.17W	Y	FB	DF	-
HAFOR	261243.07N/0795855.56W	Y	FB	TF	348.15 8.35
SECOR	261427.18N/0801120.40W	Y	FB	TF	277.66 13.08
ATONE	262312.14N/0802123.68W	Y	FB	TF	314.03 12.56
ARKES	263437.73N/0802503.60W	Y	FB	TF	343.91 11.86
RW13 (AER)	260444.05N/0800937.40W	N	-	-	CG 500 FT PER NM TO 520
520 MSL	-	-	-	135.36	-
JUN1AR	260431.29N/0795501.17W	Y	FB	DF	-
HAFOR	261243.07N/0795855.56W	Y	FB	TF	348.15 8.35
SECOR	261427.18N/0801120.40W	Y	FB	TF	277.66 13.08
ATONE	262312.14N/0802123.68W	Y	FB	TF	314.03 12.56
ARKES	263437.73N/0802503.60W	Y	FB	TF	343.91 11.86
RW27L (AER)*	260357.17N/0800040.84W	N	-	-	*DISPL THLD (142 FT)
520 MSL	-	-	-	270.39	-
NOVAE	260438.90N/0801553.29W	Y	FB	DF	-
KRMIT	261322.00N/0801816.69W	Y	FB	TF	346.11 8.95
ATONE	262312.14N/0802123.68W	Y	FB	TF	344.07 10.20
ARKES	263437.73N/0802503.60W	Y	FB	TF	343.91 11.86
RW27R (AER)*	260436.49N/0800027.45W	N	-	-	*DISPL THLD (604 FT)
520 MSL	-	-	-	270.36	-
NOVAE	260438.90N/0801553.29W	Y	FB	DF	-
KRMIT	261322.00N/0801816.69W	Y	FB	TF	346.11 8.95
ATONE	262312.14N/0802123.68W	Y	FB	TF	344.07 10.20
ARKES	263437.73N/0802503.60W	Y	FB	TF	343.91 11.86

DEPARTURE (DATA RECORD)

DP Name	Number	DP Computer Code	Superseded Number	Dated	Effective Date				
ARKES	ONE	ARKES1,ARKES	NONE						
FIX/NAVAID	LAT/LONG	C	FO/IB	TYPE	TC	(NM)	ALTITUDE	SPEED	REMARKS
RW31 (AER)	260355.70N/0800844.54W	N	-	-	-	-	-	-	*DISPL THLD (70 FT)
520 MSL	-	-	-	VA	315.37	-	-	-	CG 500 FT PER NM TO 520
NOVAE	260438.90N/0801553.29W	Y	FB	DF	-	-	-	-	LEFT TURN
KRMIT	261322.00N/0801316.69W	Y	FB	TF	346.11	8.95	-	-	
ATONE	262312.14N/0802123.68W	Y	FB	TF	344.07	10.20	-	-	
ARKES	263437.73N/0802303.60W	Y	FB	TF	343.91	11.86	-	-	

THIS PAGE INTENTIONALLY LEFT BLANK

08/20/09

8260.46D
Appendix F

Appendix F. Helicopter Departure Procedures - RESERVED

THIS PAGE INTENTIONALLY LEFT BLANK

Appendix G. Administrative Information

1. Distribution. This order is distributed in Washington headquarters to the **Group and Team** level in the Air Traffic Organization (Safety, En Route and Oceanic Services, Terminal Services, System Operations Services, Technical Operations Services, and **Mission Support Services**); to the **Branch level in the Flight Standards Service**; to the **National Flight Data Center (NFDC), AJV-21, to the National Aeronautical Navigation Products Office (AeroNav Products), AJV3,** and to the Regulatory Standards Division, **AMA-200,** at the Mike Monroney Aeronautical Center; to the branch level in the regional Flight Standards **Divisions**; to the **Team level in the ATO Service Area Operational Support Groups**; special mailing list ZVN-826; and Special Military and Public Addressees.

2. Background. The original order combined into a single product textual instrument flight rule (IFR) departure procedures that were developed by the **AeroNav Products** under the guidance of the Flight Standards Service (AFS), and graphic standard instrument departures (SIDs) that were designed and produced under the direction of the Air Traffic Organization (ATO). This combined product introduced the new acronym, Departure Procedures (DP), to the pilot/controller community and the aforementioned terms of “IFR departure procedure,” and “SID” were eliminated. The original order also provided for the graphic publication of IFR departure procedures (DP) to facilitate pilot understanding of the procedure as well as all area navigation (RNAV) and required navigation performance (RNP) DPs, both those developed solely for obstruction clearance and those developed for system enhancement. Elimination of the term “SID” created undue confusion in both the domestic and international aviation communities. Therefore, in the interest of international harmonization, the FAA reintroduced the term “SID” in Order 8260.46B while also using the term “Obstacle Departure Procedures (ODPs)” to describe certain procedures. This order defines two separate types of DPs: SIDs and ODPs and provides policy guidance for the development and documentation of each.

3. Definitions. As used in this order shall or must mean compliance is mandatory. All references to related Orders and Publications apply to the latest edition. A glossary of additional terms, abbreviations, and acronyms used in this order:

- a. **Adverse Assumption Obstacle (AAO).**
- b. **Air Route Traffic Control Center (ARTCC).**
- c. **Air Traffic Control (ATC).**
- d. **Approach End of Runway (AER).** The first portion of the runway available for landing. If the runway threshold is displaced, use the displaced threshold Lat/Long as the AER.
- e. **Area Navigation (RNAV).** A system of enhanced navigational capability that can compute aircraft position, actual track and ground speed, and then provide meaningful information relative to the route of flight selected by the pilot.

f. Climb Gradient (CG). A climb requirement expressed in ft per NM (gradient greater than 200 ft per NM).

g. Controller Chart. An aeronautical chart developed for internal air traffic controller reference in specific ATC facilities. These charts may also be used to design instrument procedures to support ATC operations.

h. Departure End of Runway (DER). The end of the runway that is opposite the landing threshold. It is sometimes referred to as the stop end of the runway.

i. Department of Defense (DoD).

j. Departure Procedure (DP). A preplanned IFR departure procedure published for pilot use, in graphic or textual format, that provides obstruction clearance from the terminal area to the en route structure. There are two types of DPs - Obstacle Departure Procedures (ODP) printed either textually or graphically, and Standard Instrument Departure (SID) which is always printed graphically.

k. Diverse Vector Area (DVA). An area in a radar environment established at the request of Air Traffic, and jointly developed with the FPO, that meets terminal instrument procedures (TERPS) criteria for diverse departures, obstacles and terrain avoidance in which random radar vectors below the MVA/MIA may be issued to departing aircraft.

l. Electronic Transmission. Transmittal via electronic mail (e-mail) or facsimile (FAX).

m. Fix. A generic term used to define a predetermined geographical position used for route definition. A fix may be a ground-based NAVAID, a waypoint, or defined by reference to one or more radio NAVAIDs.

n. Flight Procedures Team (FPT). An element of **Mission Support Services**, geographically located at each Air Traffic Service **Center**.

o. Fly-By Waypoint. A fly-by waypoint requires the use of turn anticipation to avoid overshoot of the next flight segment.

p. Fly-Over Waypoint. A fly-over waypoint precludes any turn until the waypoint is overflown and is followed either by an intercept maneuver of the next flight segment or direct flight to the next waypoint.

q. Initial Climb Area (ICA). An area beginning at the departure end of runway (DER) to provide unrestricted climb to at least 400 ft above DER elevation.

r. Initial Departure Fix (IDF). The first published fix/waypoint used for the departure. The IDF denotes the beginning of the RNAV portion of the SID.

Note: “IF” is used for coding (per ARINC 424) of the IDF. “IF” or “IDF” will not be placed on a departure chart in order to prevent confusion. The “IF” acronym is also used in conjunction with the intermediate fix of an instrument approach procedure.

s. Lead Carrier. An air carrier or operator that has agreed to serve as the focal point for the development of DPs at a specific airport. The lead carrier agrees to help develop the DP and conducts initial flyability evaluations by all RNAV-equipped aircraft expected to use the DP.

t. Least Onerous Route. The obstacle DP route established over terrain or other obstacles that result in the lowest possible climb gradient for that runway.

u. National Flight Data Center (NFDC). The FAA office responsible for the collection, validation, and dissemination of all aeronautical information relating to the NAS.

v. National Flight Data Digest (NFDD). A daily publication, prepared by the NFDC to promulgate non-regulatory changes to the NAS.

w. Navigational Aid (NAVAID). See Aeronautical Information Manual (AIM). Any visual or electronics device airborne or on the surface which provides point-to-point guidance information or position data to aircraft in flight.

y. Non-RNAV DP. A DP whose ground track is based on ground-based NAVAIDs and/or dead reckoning navigation.

z. Obstacle Clearance Surface (OCS). An inclined surface associated with a defined area for obstruction evaluation.

aa. Obstacle Departure Procedure (ODP). A preplanned IFR departure procedure printed for pilot use in textual or graphic form to provide obstruction clearance via the least onerous route from the terminal area to the appropriate en route structure. ODPs provide obstruction clearance and may be flown without ATC clearance unless an alternate departure procedure (SID or radar vector) has been specifically assigned by ATC.

bb. Proponent. The originator of a DP requirement. This may include an individual user group, ATC, **AeroNav Services**, or other appropriate government agency.

cc. Radar SID. A SID established when ATC has a need to vector aircraft on departure to a particular ATS Route, NAVAID, or fix.

dd. Regional Airspace and Procedures Team (RAPT). A team **established for** the purpose of coordinating and processing requests for new or modified flight procedures and related airspace matters (see Order 8260.43).

ee. RNAV DP. A DP developed for RNAV-equipped aircraft whose ground track is based on satellite or distance measuring equipment (DME)/DME navigation systems.

ff. Required Navigation Performance (RNP). A statement of the navigational performance accuracy necessary for operation within defined airspace. See the AIM for current definition.

gg. Runway Heading. The magnetic direction that corresponds with the runway centerline extended, not the painted runway numbers on the runway. Pilots cleared to “fly or maintain runway heading” are expected to fly or maintain the published heading that corresponds with the extended centerline of the departure runway (until otherwise instructed by ATC), and are not to apply drift correction; e.g., RWY 4, actual magnetic heading of the runway centerline 044.22 degrees, fly 044 degrees.

hh. SID Transition. A published segment used to connect the SID to one or several en route airways/jet routes.

ii. Significant Benefits. Tangible or intangible advantages resulting from the implementation of a DP such as fuel savings from reduced flight tracks and time, reduced inter-/intra-facility coordination, reduced communications between ATC and pilots, increased flexibility of airspace management and sectorization due to more predictable ground tracks, or other similar benefits to users or providers.

jj. Standard Instrument Departure (SID). A preplanned IFR ATC departure procedure printed in graphic form for pilot/controller use to provide obstacle clearance and a transition from the terminal area to the appropriate en route structure. SIDs are primarily designed for system enhancement to expedite traffic flow and to reduce pilot/controller workload. ATC clearance must be received prior to flying a SID.

kk. Terminal Area Route Generation Evaluation and Traffic Simulation (TARGETS). An air traffic tool for RNAV DP design.

II. TERPS. FAA Order 8260.3, United States Standard for Terminal Instrument Procedures.

mm. Transmittal Letter (TL). A biweekly publication, prepared by the NFDC, used as the medium to promulgate instrument approach procedures and textual ODPs and their effective dates for publication.

nn. Visual Climb over the Airport (VCOA). Option to allow an aircraft to climb over the airport with visual reference to obstacles to attain a suitable altitude from which to proceed with an IFR departure.

oo. Waypoint (WP). A predetermined geographical position used for route definition and/or progress-reporting purposes defined by latitude/longitude and may include elevation.

4. Related Publications.

- a. **Order 1050.1,** Policies and Procedures for Considering Environmental Impacts

- b. **Order 7100.9**, Standard Terminal Arrival Program and Procedures.
 - c. **Order 7210.3**, Facility Operation and Administration
 - d. **Order 7400.2**, Procedures for Handling Airspace Matters.
 - e. **Order 8260.3**, United States Standard for Terminal Instrument Procedures (TERPS).
 - f. **Order 8260.19**, Flight Procedures and Airspace.
 - g. **Order 8260.26**, Establishing and Scheduling Standard Instrument Procedure Effective Dates.
 - h. **Order 8260.40**, Flight Management System (FMS) Instrument Procedure Development.
 - i. **Order 8260.43**, Flight Procedures Management Program.
 - j. **Order 8260.44**, Civil Utilization of Area Navigation (RNAV) Departure Procedures.
 - k. **Order 8260.53**, Standard Instrument Departures that Use Radar Vectors to Join RNAV Routes.
 - l. **Advisory Circular 90-100**, United States Terminal and En route Area Navigation (RNAV) Operations.
 - m. **Advisory Circular 90-105**, Approval Guidance for RNP Operations and Barometric Vertical Navigation in the U.S. National Airspace System.
 - n. **RTCA DO-187**, Minimum Operational Performance Standards for Airborne Area Navigation Equipment Using Multi-Sensor Inputs.
 - o. **ARINC Specification 424**, Navigation System Data Base.
 - p. **IACC No. 4**, Interagency Air Cartographic Committee Chart Specification for Low Altitude Instrument Approach Procedures.
 - q. **IACC No. 7**, Interagency Air Cartographic Committee Chart Specification for Standard Instrument Departure Charts.
 - r. **IACC No. 17**, Interagency Air Cartographic Committee Chart Specification for Terminal Procedures Publications.
- 5. Forms and Reports.** Appendices B, C, D, and E contain requirements data, applicable forms, and associated instructions.

6. Information Update. For your convenience, FAA Form 1320-19, *Directive Feedback Information*, is included at the end of this order to note any deficiencies found, clarifications needed, or suggested improvements regarding the contents of this order. When forwarding your comments to the originating office for consideration, please provide a complete explanation of why the suggested change is necessary.

Directive Feedback Information

Please submit any written comments or recommendation for improving this directive, or suggest new items or subjects to be added to it. Also, if you find an error, please tell us about it.

Subject: Order 8260.46D, Departure Procedure (DP) Program

To: Directive Management Officer, _____

(Please check all appropriate line items)

- An error (procedural or typographical) has been noted in paragraph _____ on page _____ .
- Recommend paragraph _____ on page _____ be changed as follows:
(attached separate sheet if necessary)

- In a future change to this order, please include coverage on the following subject
(briefly describe what you want added):

Other comments:

I would like to discuss the above. Please contact me.

Submitted by: _____ Date: _____

Telephone Number: _____ Routing Symbol: _____

THIS PAGE INTENTIONALLY LEFT BLANK

CHANGE

**U.S. DEPARTMENT OF TRANSPORTATION
FEDERAL AVIATION ADMINISTRATION**

8260.46D
CHG 1

Effective Date:
04/14/11

National Policy

SUBJ: Departure Procedure (DP) Program

1. Purpose. This order provides policy, guidance, and standardization for initiating, developing, processing, and managing the Departure Procedure program.

2. Who this change affects. The primary audience for this Order is AeroNav Services, who have the responsibility to develop instrument departure procedures. The secondary audience includes other Air Traffic Organization (ATO) Service Area offices and Flight Standards headquarters and regional office Divisions/Branches.

3. Where Can I Find This Notice? Inspectors can access this order through the Flight Standards Information Management System (FSIMS) at <http://fsims.avs.faa.gov>. Operators may find this information on the Federal Aviation Administration's (FAA) Web site at http://www.faa.gov/library/manual/examiners_inspectors/8000.

4. Explanation of changes.

a. General. Changed reference from National Flight Procedures Office (NFPO) and National Aeronautical Charting Office (NACO) to AeroNav Products.

b. Chapter 1. Editorial correction. Removed incorrect paragraph change references from paragraph 1-6o and 1-6t. Remaining paragraphs re-lettered.

c. Chapter 2.

(1) Paragraph 2-1b(2). Revised to "Do not publish text that allows an option to use a SID or alternate maneuver assigned by ATC; e.g., "Climb runway heading to 1200 before turning or use Manchester Departure" or "Turn right, climb direct ABC VOR or as assigned by ATC.""

(2) Paragraph 2-1b(11). Added "When a Visual Climb Over Airport (VCOA) has been established, a note must be established that requires the pilot to inform ATC prior to departure when executing the VCOA."

(3) Paragraph 2-1b(14). Added “Textual ODPs may be designed to terminate at a fix/NAVAID located within the IFR en route structure and/or at an altitude that will allow random (diverse) IFR flight.”

(4) Table 1. Editorial.

(5) Paragraph 2-1c(2). Deleted guidance Diverse Vector Area and split paragraph 2-1c(1) into two paragraphs, making the second sentence the new paragraph 2-1c(2).

(6) Paragraph 2-1e(1)(a). Added “amended/” prior to cancelled to make it clear that ATC can also amend an altitude that is annotated with “(ATC)” adjacent to the number.

(7) Paragraph 2-2a(1) & (2). Introduced the Service Area Operations Support Group (OSG), Flight Procedures Team (FPT) as part of process to establish/modify SIDs.

(8) Paragraph 2-2c(6) and 7. Removed paragraphs. Environmental Requirements are addressed in other FAA directives and guidance not required in this order.

(9) Paragraph 2-2c. Switched order of sub-paragraphs 6 and 7, and removed the Note from the new sub-paragraph 6.

(10) Paragraph 2-2c(12). Deleted. RAPT and/or ATC facility does not distribute these.

(11) Paragraph 2-2d. Renamed paragraph to “Service Area Flight Procedures Office”

(11) Paragraph 2-2d(5). Modified text to correspond with paragraph 2-2e(7).

(12) Paragraph 2-2e(4). Editorial change to show Service Area OSG is responsible for DME/DME screening.

(13) Paragraph 2-2e(7). Editorial change to show distribution responsibility and correspond with paragraph 2-2d(5).

(14) Paragraph 2-2f added, following paragraph up-lettered. Added Aviation System Standards responsibilities.

(15) Paragraph 2-4b. Changed second sentence to reflect correct ATO responsibility.

d. Appendix A.

(1) Paragraph 1f. Changed sentence to refer to “Graphic ODPs” only.

(2) Table A-1. Changed Table notes ² to state “VA (Heading-to-an-altitude) may only be used as the first leg of a departure and must be followed by a DF leg.”

(3) Paragraph 5e(5). Changed to state “Except as required by paragraph 2-1f(3), all.”

(4) Paragraph 5e(5) examples. Revised graphics for “Shemp One Departure (RNAV)” and “Shemp Two Departure (RNAV)” to support text revisions.

e. Appendix C.

(1) Instructions updated to include guidance for updating “Fix Use” when applicable.

f. Appendix D.

(1) Section 1, paragraph 1. Emphasized “If all runways are standard...” and added “(e.g., no ODP required).”

(2) Section 1, Paragraph 6. Editorial, corrected paragraph reference.

(3) Section 1, Paragraph 7a(1). Changed to “HEADING 350.11.”

(4) Section 1, Paragraph 7a(7). Added “Additionally, the statement “Notify ATC prior to executing VCOA” must be included at the end.”

(5) Section 1, Paragraph 8b. Added “0.1 NM.”

(6) Section 1, Paragraph 10. Added “Remarks” block and reference to Order 8260.19 paragraph 8-71g, requiring a chart note when ODP is a Special. Updated figures D-1 thru D-5.

(7) Section 2, Paragraph 3b, Note 1. Added “(or required nonstandard “minimum” climb gradient).”

(8) Section 2, Paragraph 6b. Added “0.1 NM.”

(9) Figure D-2. Updated, added “When Executing VCOA, Notify ATC Prior to departure.”

(10) Figure D-6. Updated, added visibility value and “When Executing VCOA, Notify ATC Prior to Departure.”

g. Appendix E.

(1) Section 1, Paragraph 3b, Note 1. Added “(or required nonstandard “minimum” climb gradient).”

(2) Section 1, Table E-1. Removed “altitude” and accompanying asterisk reference.

(3) Section 1, paragraph 3e, Examples. Removed example that showed an altitude in conjunction with a VI leg followed by a CF leg.

(4) Section 1, Paragraph 5a. Added reference to Order 8260.19 paragraph 8-71g, requiring a chart note when ODP is a Special.

(5) Section 1, Paragraph 6b. Added "0.1 NM."

(6) Section 2, Paragraph 4b(3). Removed ability to develop procedures using VA/CF leg type combination.

h. Appendix G. Removed National Aeronautical Charting Office (NACO) and National Flight Procedures Office (NFPO) definitions from paragraph 3u and 3b. Remaining paragraphs re-lettered.

PAGE CHANGE CONTROL CHART

Remove Pages	Dated	Insert Pages	Dated
Table of Contents i and ii	08/20/09	Table of Contents i and ii	04/14/11
Chapter 1 1-1 thru 1-4	08/20/09	Chapter 1 1-1 thru 1-4	04/14/11
Chapter 2 2-1 thru 2-16	08/20/09	Chapter 2 2-1 thru 2-16	04/14/11
Appendix A A-1 thru A-8	08/20/09	Appendix A A-1 thru A-8	04/14/11
Appendix B B-1 thru B-2	08/20/09	Appendix B B-1 thru B-2	04/14/11
Appendix C C-1 thru C-2	08/20/09	Appendix C C-1 thru C-2	04/14/11
Appendix D D-1 thru D-28	08/20/09	Appendix D D-1 thru D-28	04/14/11
Appendix E E-1 thru E-6 E-9 thru E-16 E-19 thru E-26	08/20/09 08/20/09 08/20/09	Appendix E E-1 thru E-6 E-9 thru E-16 E-19 thru E-26	04/14/11 04/14/11 04/14/11
Appendix G G-1 thru G-6	08/20/09	Appendix G G-1 thru G-6	04/14/11

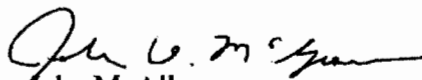
John M. Allen
Director
Flight Standards Service

CHANGE

**U.S. DEPARTMENT OF TRANSPORTATION
FEDERAL AVIATION ADMINISTRATION**

8260.46D
CHG 2

Effective Date:
09/30/11

National Policy

SUBJ: Departure Procedure (DP) Program

1. Purpose. This order provides policy, guidance, and standardization for initiating, developing, processing, and managing the Departure Procedure program.

2. Who this change affects. The primary audience for this Order is AeroNav Products, who has the responsibility to develop instrument departure procedures. The secondary audience includes other Air Traffic Organization (ATO) Service Area offices and Flight Standards headquarters and regional office Divisions/Branches.

3. Where You Can Find This Order. You can find this order on the Federal Aviation Administration's (FAA) Web site at http://www.faa.gov/regulations_policies/orders_notices.

4. Explanation of changes.

a. Chapter 2.

(1) Paragraph 2-1b(13). Editorial change to indicate VCOA is not mandatory at airport where ATC cannot allow the maneuver. Also added statement to say that Form 8260-15B will contain this information when the ODP is in a graphic.

(2) Paragraph 2-1e. Revised guidance on documenting crossing altitudes.

(3) Paragraph 2-1e(2). Revised paragraph to support the revision of paragraph 2-1e(1) that eliminates the need to differentiate between climb gradients for either ATC purposes or obstacle clearance. There is no way to determine if the altitude depicted on the chart is for obstacle clearance or to meet an ATC requirement; therefore, the crossing altitude/climb gradient must be complied with unless ATC intervenes and assumes responsibility for obstacle avoidance.

(4) Paragraph 2-2e(12). Added requirement to include "T" symbol on SIDs and clarified in the Note that the "T" symbol will not be placed on graphic ODPs.

b. Appendix A. Paragraph 5e(5) examples. Revised graphics for "Elemo Two Departure," "Micky Four Departure," "Shemp One Departure (RNAV)," and "Shemp Two Departure (RNAV)" to support text revisions.

c. Appendix D.

- (1) Section 2, Paragraph 3. Revised guidance on documenting crossing altitudes.
- (2) Section 2, Paragraph 4i. Removed "(ATC)" reference.
- (2) Section 2, Figure D-7. Revised FAA Form 8260-15B for "Micky Four Departure," to support revised application guidance.

d. Appendix E.

- (1) Section 1, Paragraph 3. Revised guidance on documenting crossing altitudes.
- (2) Section 1, Paragraph 4i. Removed "(ATC)" reference.
- (3) Section 1, Figure E-2. Revised FAA Form 8260-15B for "Shemp One Departure (RNAV)," to support revised application guidance.
- (4) Section 1, Figure E-3. Revised FAA Form 8260-15B for "Shemp Two Departure (RNAV)," to support revised application guidance.
- (5) Section 2, Paragraph 1h. Modify paragraph to allow use of block altitudes.
- (6) Section 2, Figure E-7. Revised FAA Form 8260-15C for "Shemp Two Departure (RNAV)," to support revised application guidance.

PAGE CHANGE CONTROL CHART

Remove Pages	Dated	Insert Pages	Dated
2-3 thru 2-16	04/14/11	2-3 thru 2-16	09/30/11
A-7 thru A-8	04/14/11	A-7 thru A-8	09/30/11
D-17 thru D-22	04/14/11	D-17 thru D-22	09/30/11
D-25 thru D-26	04/14/11	D-25 thru D-26	09/30/11
E-1 thru E-8	04/14/11	E-1 thru E-8	09/30/11
E-11 thru E-14	04/14/11	E-11 thru E-14	09/30/11
E-21 thru E-30	04/14/11	E-21 thru E-30	09/30/11

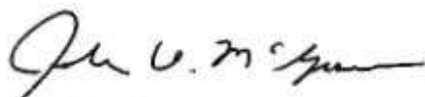

John M. Allen
 Director
 Flight Standards Service