

Land Rover Freelander

1997-06



Quick Summary

Possibly the most incompetently designed and built four-wheel drive in history.

How Reliable?

Appalling. See 'what goes wrong' below 🖱️

How Safe?

Dodgy: see the safety summary below 🖱️

OVERALL RATING **AVOID like the PLAGUE**



★ ★ ★ ★ ★

ALSO CONSIDER: Hyundai Sante Fe (late models), Honda CR-V, or Toyota Rav4.







1998-01

-  \$5000–\$8000
-  \$3000–\$7000
-  \$500–\$3000



2002-06

-  \$6000–\$16,000
-  \$5000–\$14,000
-  \$2000–\$13,000



(for used car dealers add around 30%, incl. GST)



1998-01

-  \$4000–\$7500
-  \$1800–\$6000

2002-07

-  \$9000–\$24,000
-  \$7000–\$16,000

(for used car dealers add around 30%, incl. GST)



-  = 'new or like-new'
-  = 'average'
-  = 'rough or high mileage'
-  = Japanese secondhand import
-  = all countries





1998-01

 £800–£2000

 £250–£1500

2002-06

 £2000–£10,000

 £1000–£7500

(for used car dealers add around 30%, incl. VAT)



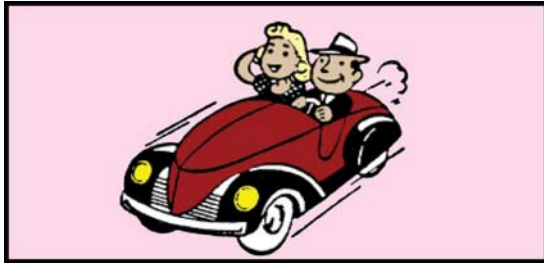

General blurb

THERE'S a weird story of how the Land Rover Freelander came into being; believe it or not, the Honda CR-V and the Land Rover Freelander are actually distant cousins. If you've got time, you should read this story. If not, skip down a few paragraphs to the review itself.

Britain's car industry had been in decline for decades by the time the government nationalised most of it in 1975. The nationalised British car companies were turned into a corporation called *British Leyland*, which owned, among other brands, Rover and Land Rover.

The new chairman of British Leyland, Sir Michael Edwardes, closed down or sold off most of the British Leyland companies and in 1982 re-named the company as the *Austin Rover Group*, later shortened to just the *Rover Group*.

As part of the modernisation of the Rover Group, Edwardes arranged a deal with the Honda Motor Co to share technology and manufacturing facilities in England.



Thus, Honda gained access to the lucrative European market, while Rover gained access to successful Honda technology.

For this reason, most Rover cars of the era were based around existing Honda vehicles and many used a combination of Honda and Rover technology. One of the Honda-Rover joint projects was a small SUV, to be built using a combination of Honda and Rover parts.

In 1988, the Rover Group was privatised and sold off to British Aerospace. However, by 1991 British Aerospace was in financial trouble as well. The Rover Group was still bleeding money, so British Aerospace sold the Rover Group to BMW without consulting Honda.

Stunned at this sudden reversal, Honda withdrew from its arrangement with the Rover Group and retreated back to Japan.

Safe at home, Honda proceeded with its own version of the planned SUV – based on the Honda Civic – and later released it as the original Honda CR-V.

Rover – known within BMW as ‘The English Patient’ – was left to continue with its SUV project, which became the Freelander.



In order to save money, Rover didn't design this new vehicle from scratch, instead they recycled the basic body of the Rover 200, which in turn was also a recycled 1980s Honda Civic.

Despite having billions in funding from BMW, Rover managed the breathtaking feat of utilising the worst bits of the Honda-Rover vehicles, such as the flimsy Honda Civic body, while filling this flimsy body with utterly inept British and European technology.

Rover's poorly designed and badly assembled technology was one of the main reasons the Rover Group went bankrupt in 2005.



The Freelander was released onto the market with over 132 serious faults, all of which were known to Land Rover management as the vehicles rolled out the door.

Early versions for motoring journalists were hand-picked, because anything else was likely to break down.



You'd think that the people who produced this car would be in prison. But that's not how it works in the motor industry.

For producing one of the most incompetently designed and built four-wheel drives in history, Land Rover was rewarded with record sales. In fact, between 1997 and 2002, the Freelander was Europe's best-selling four-wheel drive.



Why didn't the motoring press expose this scam? Because – mostly – they're part of it.

Even when motoring journalists – especially British journalists – acknowledge Land Rover's appalling track record, they tend to use euphemisms such as: "The Land Rover's reliability hasn't always been perfect".

The tone of the review is always that of a stern headmaster with a twinkle in his eye, mildly rebuking a bright but mischievous pupil.



If there's any justice in the universe, the journalists who recommended these vehicles will spend all eternity fixing broken down Land Rovers in the middle of some hellish wilderness, with hyenas snapping at their heels. Because that's the fate that many Land Rover owners have suffered.



The entire Land Rover range hovers, gloriously, around the bottom of any reliability survey.

Most owners who say their Land Rovers have been reliable are English and they are frequently in a state of near-total denial. Just after telling you that their vehicle has been very reliable, they'll acknowledge that they might have had 'one or two issues'. That's a bit like an alcoholic saying he might have had one or two drinks.





And yet, people keep buying Land Rovers, including the Freelander.

Not only are most Europeans in denial about how bad Land Rovers and other Euro models are, but they seem to believe that considering a car from Japan or Korea would mean a loss of face.

This is because European – and especially British – car purchases are based on snobbery: I'm better than you, higher up the food chain than you, wealthier than you, more fashionable than you – and I can prove it by my vehicle.

Thus, when you point out to many wealthy English folk that a Honda or Toyota will leave any European car for dead when it comes to both value and reliability, your words will fall on deaf ears.



Affordability and reliability, to the English snob, are obsessions of the poor and needy – if those considerations are a high priority, it means that you're in the lower part of the food chain.

This snobbish pomposity, of course, costs them dearly. Every European carmaker is dedicated to emptying the wallets of gullible snobs. In exchange for the temporary thrill of having the latest model in the office carpark, the snobbish buyer is probably going to have to put in several extra months or years of hard grind in order to pay the inflated purchase price plus the exorbitant interest on the hire purchase.

This shiny piece of fragile automotive status will be out of date in two or three years, and will have lost most of its value by then. Madness.





The Freelander was offered in two basic versions: a three-door and a five-door, with variations such as convertible roof on three-door versions. Most people opted for five-door versions due to the near-total lack of space in the rear of three-door versions.



The Freelander had a visual freshen-up in 2002 and again in 2004, with some of the more dire mechanical bits replaced with bits that were almost as bad.





The Freelander's height above smaller passenger cars and commanding driving position make it a satisfying city commuter.

Many of the Freelander's owners have been urban women, which is unsurprising, because the Freelander is more suited to small-to-average sized rather than tall people.

In order to gain that SUV sense of elevation and importance, the front seats have been positioned far too high, so that tall people will find their heads hitting the roof. Tall people will also find it difficult to see clearly out the front windscreen. Worse, there's no height adjustment for the front seats. There's no need for this high seating position; it's just designed to make small people feel bigger.



For small-to-average sized people, the Freelander's front seats are comfortable and reasonably supportive.



Depending on how much you spent, your Freelander could get leather and other luxury add-ons, none of very good quality.

The Freelander's cabin is a strange combination of simple functionality and weird dysfunctionality. Many of the switches seem to have been positioned by someone throwing them at random towards the front of the vehicle. Much of the switchgear was of dubious quality, even when new, and these vehicles are a long way from new.



The Freelander's rear passengers are treated as second-class citizens. The doorways are too small, while the seats themselves are small, flat, unresponsive benches.

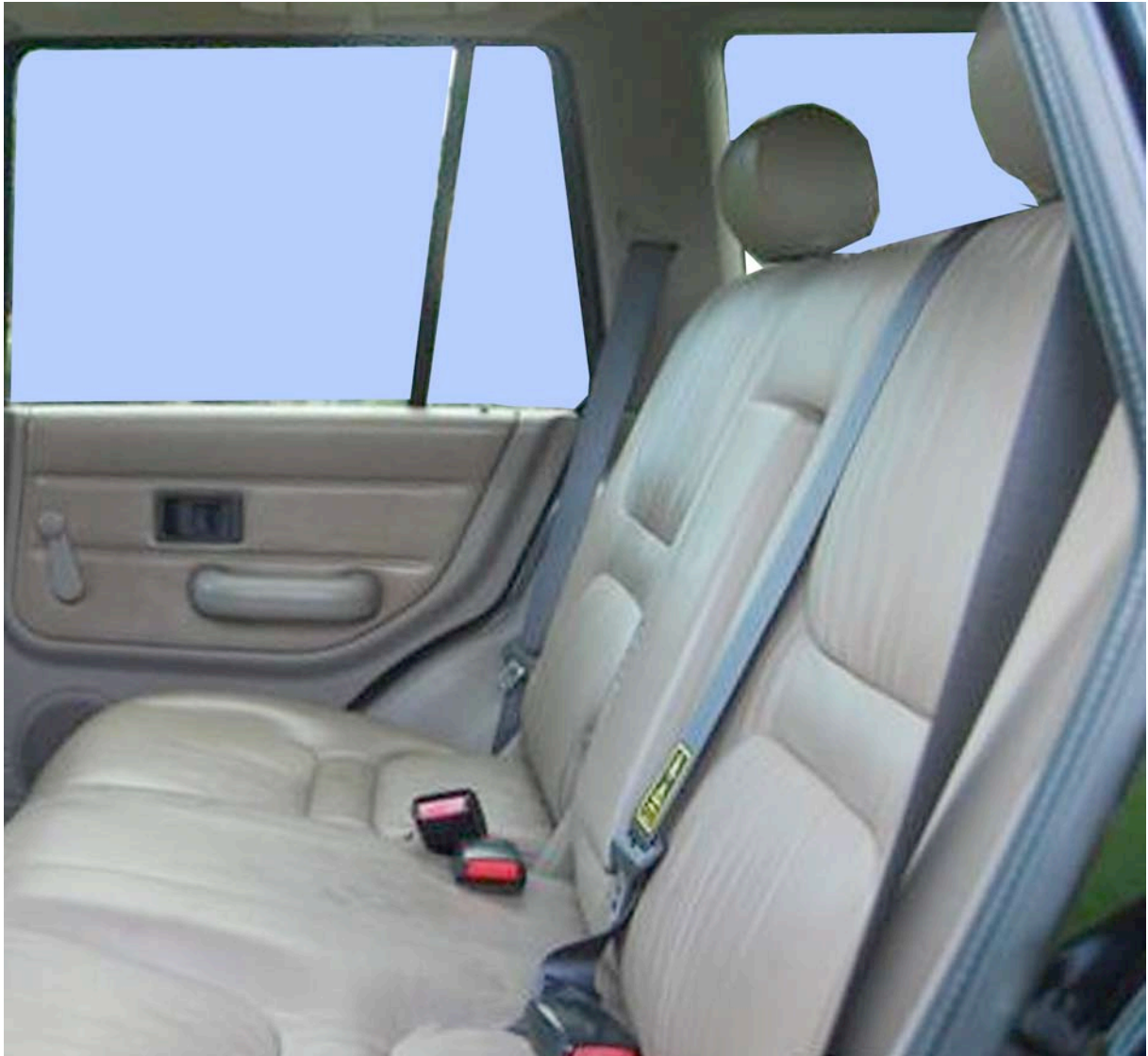

Behind the seats is a pretty small luggage area, even on the five-door version.



When the rear seats are not in use, they split and fold for extra luggage storage. With the rear seats folded, you have a slightly more feasible luggage storage area.

However, the tapered luggage compartment entrance effectively blocks the unused storage space ahead.

The rear door has another problem: the hatch opens sideways like a gate.

In tight car parking spaces, such as in a domestic garage, there simply isn't enough room to open the rear door wide. Dumb.



Slightly less dumb is the position of the spare tyre, on the back of the rear door. With the spare tyre on the rear door, it's easily accessible in the event of a puncture.



There are two downsides of having the spare in this position: the first is that it obscures rear vision. The second is that it's extremely vulnerable to damage when reversing. If you back into a lamppost, the spare tyre will quite likely distort the whole rear door. This won't be cheap to repair.

It would also be frighteningly easy to reverse straight over a child.

Our advice, if you end up owning a Freelander, is to simply fit your own aftermarket reversing camera. You might save a child's life.





There were four engine options with the Freelander: a 1.8-litre petrol, a 2.5-litre V6 petrol, a lethargic Rover 2-litre diesel and a more sprightly BMW-sourced 2-litre diesel.

Of the four engines, the two diesels are easily the best of a very bad bunch.

The Rover 1.8 and 2.5 V6 petrol engines were designed by Satan and assembled by monkeys. Many Freelander owners needed new petrol engines from as little as 10,000km from new. Few engines made it to 50,000km; almost none made it to 70,000km.

Due to design flaws within these engines, a total – and very expensive – rebuild is the only option once they blow their head gaskets, which they all do.

The diesels, as we have said, are the best of a bad bunch, although they, too, are a long way from perfect.



Early Rover diesel engines have a nasty habit of breaking timing belts at low mileages, destroying much of the engine in the process.

Later (BMW) diesel engines often blow their turbochargers and they're massively expensive to fix.

Gearbox options were a five-speed manual and a five-speed automatic.

The automatics have a 'Steptronic' option that allows the driver to select when the automatic changes gear.

The manual gearbox was notchy (hard to select gears) from new and is prone to early failure, although it's still light years ahead of its automatic sibling.





Compared to many modern equivalents, the Freelander is not an especially pleasant drive.

The ride is roly-poly on bends, the steering is slow and, under pressure, the Freelander prefers continuing in a straight line instead of navigating sharp corners.

However, the Freelander is a nice vehicle on long, straight roads.

Reliability aside, the petrol engines aren't especially frugal.

The 1.8 petrol is always working too hard and therefore drinks too much.

The 2.5 petrol is more relaxed and is pleasant to drive on all types of roads, but still drinks like a fish.



The two diesel engines are both brilliantly economical and pleasant to drive on the open road.

The early (Rover) diesel engine feels a bit like a pensioner and doesn't like sudden overtaking.

The later (BMW) diesel is in its element on the open road.

However, neither of the two diesels like city traffic. The drive becomes lurchy and buzzy and there's invariably a long pause between putting your foot down and anything useful happening. This long pause, known as turbo lag, often makes it very stressful to try and enter a stream of fast-moving traffic.

In stop-start rush hour traffic you proceed in a series of low-speed lurches.





In line with Land Rover's vast experience with four-wheel drive vehicles, the Freelander's offroad handling is surprisingly good.

We say 'surprisingly', because although all Freelanders have sort-of four-wheel drive, it's a road-oriented system: most of the time, the Freelander's front wheels are the only ones doing anything useful. The rear wheels only wake up when the front wheels begin slipping.

However, while the Freelander is great on muddy paddocks and sand dunes, it lacks the low gearing required to navigate the really tricky bits.

Moreover, the *Freelander's Hill Descent Control*, which is meant to ensure that you don't start skidding while descending slippery banks, operates at too high a speed to be of much use in many real-life offroad situations.



Even if this vehicle were reliable you'd be brave taking it anywhere more rugged than a farmer's field.

It's not just the crude four-wheel drive system that will let you down. Early versions quickly developed cracks in the chassis even after being driven around town.

On versions before 2004, a large hunk of the rear suspension (the cross member) is liable to unceremoniously part company with the rest of the vehicle as you drive down the road. Or across a field.

Remember that underneath the butch offroad looks, the Freelander is really a modified 1980s Honda Civic body on stilts. It simply can't stand the rough stuff; you'd be unwise to trust this vehicle on important trips offroad.



<http://www.burnham-on-sea.com/coastguard/11-07-06.shtml>





The Land Rover Freelander, in case you have thusfar missed our point, is a truly dreadful vehicle. No matter how much you like the looks or the price, the Freelander is off the buyer's list for any sane person.

Every single customer reliability survey has placed these vehicles somewhere near the very bottom. The only offroad vehicle that did worse, in fact, was the previous model Range Rover. Ford's brief ownership of Land Rover at the turn of the century did not result in any significant improvement in quality.

The most likely reason that the Freelander you're looking at is for sale is because the previous owner has just gone bankrupt from paying for repairs. No matter how cheap, these vehicles are a very, very bad joke, and the joke is invariably on the poor fool who buys one.



If you buy a Land Rover Freelander, you deserve everything you get. *See also our comments on 'British Cars', 'Diesels', 'Four-Wheel Drives' 'Turbochargers' & 'Yuppie Four-Wheel Drives' in the links page that follows this review, and for Land Rover at the end of this review.*

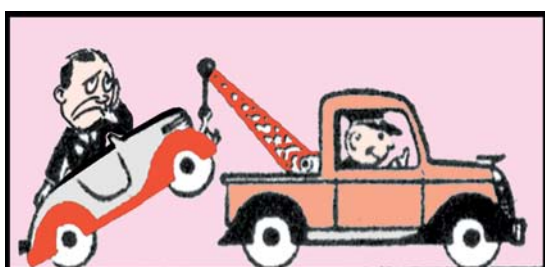

What goes wrong?

Engine problems

- **Blown head gaskets** are very common on Rover K-series petrol engines, due to abysmal engine design. All Rover K-series engines use steel cylinder liners in an aluminium block. Because the engine block and cylinder head are composed of different materials, they expand at different rates when they heat up during running of the vehicle. Because the steel liners are harder than the alloy block, they gradually work their way down into the block. When they get low enough, the cylinder liners leave a gap at the top that allows exhaust gases to leak out of the combustion chamber.



Eventually these leaking exhaust gases eat away at the head gasket, causing the head gasket to fail. By the time the head gasket blows, the damage to the engine block means that **the entire engine must be rebuilt** (there is no economically viable way of repairing this damage). A secondhand engine is likely to be nearly as bad as the one you are replacing • See our general head gasket warning at the end of this review.

- **Inlet manifold gaskets** die young on 1.8 petrol motors, leading to coolant loss, and then overheating and blown head gaskets. Early models are worst. Later models are better, but only by comparison. The head gaskets on earlier vehicles can be upgraded, but often by the time a head gasket is blown, the engine block is wrecked as well.
- **The accelerator of 1.8 petrol models jams on.** This has been linked to a number of accidents.
- The HT leads on petrol versions are prone to chafing against the engine or air intake, causing misfiring.



- The **timing belt** on petrol engines must be replaced (along with all accompanying parts, including tensioners and water pump) at 115,000km or catastrophic engine damage may occur (that's in theory; in practice, few petrol engines ever get to this ripe old age without blowing up from other causes).

On early (Rover-sourced) diesel engines the recommended replacement interval is 75,000km, but many specialists replace the timing belt and all its accessories at least every 60,000km in order to avoid catastrophe. A replacement kit that extends the life of the belt is available, but it is extremely labour-intensive to install. Later (BMW-sourced) diesel engines use a timing chain, not a belt, and this is meant to last the lifetime of the engine. • *See our article 'A Question of Timing' in the links page that follows this review.*

- The early diesel engines (an L-series Rover unit) have a number of issues: they develop oil leaks, which tend to mean a tired engine, especially if accompanied by rattles and blue smoke. However, they frequently leak around the oil filter simply because the oil filter wasn't tightened enough.



More seriously, the ECU and air flow meter lose the plot with time, and replacement is often your only option. Symptoms include loss of power and/or hard starting and/or rough idle. Please note that the ECU is extremely prone to damage caused by jump starting.

L-series cylinder heads sometimes go porous around the glow plugs. It is also important that the cooling system is bled properly after coolant change, or air locks may cause the engine to over-heat. Overheating one of these will cause head gasket / cylinder head failure, which is often extremely expensive to fix.

- **See our general head gasket warning at the end of this review.**

See also our timing belt warning above. Like any diesel, injectors and glow plugs die with time. Therefore, if these have not already been replaced, they'll probably need doing soon. Diesel pumps for these engines are now dying regularly and are increasingly difficult to buy cheaply. Turbochargers rarely last as long as the engine they're bolted to.

- The BMW-sourced TD4 diesel engine is prone to problems earlier than the Rover diesel engine simply because it works harder.



The TD4's electric diesel pumps fail regularly. The engine wiring harness is also prone to connection problems and damage caused by rubbing against the engine. Land Rover put out a modified harness in an attempt to solve these problems (see the recall below, which regrettably only covers a limited number of petrol-engined cars).

TD4s also give the usual diesel problems such as faulty air flow meter, fuel cut-off solenoids, air-contaminated fuel, blocked fuel filter, leaky vacuum pipes, faulty injectors, camshaft position sensors, glow plugs and, more expensively, the ECU. The injectors are a common failure point. The worst fault on the TD4, however, is turbocharger failure, which is reasonably common. Due to access problems, to replace the turbocharger you need to remove the injectors, rocker cover, air cleaner box and intercooler. This is a very expensive repair.

Turbocharger failure is often caused by a blocked or restricted engine breather system. On the TD4, there's a crankcase breather assembly mounted within the camshaft valve cover. Most diesel specialists recommend that this breather assembly be replaced regularly.



The EGR valve must also be regularly cleaned and/or replaced, because if either the breather system or EGR stops working properly, the crankcase may become over-pressurised and blow the turbo.

The other really expensive repair is camshaft replacement (there are two), which also requires the timing chain and tensioners to be replaced and is horrifically labour-intensive. Camshaft repair is usually done on engines that are being overhauled anyway but sometimes occurs where owners haven't changed the oil regularly, meaning the lobes start wearing out. The engine then starts getting really rattly.

Last but not least, these engines blow head gaskets at high mileages or if overheated badly and some will need a replacement cylinder head afterwards as well • **See our general head gasket warning at the end of this review.**

- Rattly exhausts often need replacement or repair.



SAFETY RECALL

 **Freelander models built between August & November 2000** • The engine wiring harness rubs against the fusebox, possibly causing failure of half the car's electronics, including headlamps, engine management, cooling fans, fuel pump, ignition circuit, air-conditioning, anti-lock braking (although brakes will still function) and hill descent control.

- **VIN numbers:**

1A576764 – 1A599999; 1A200000 – 1A312726

Google  VOSA UK [R/2001/018](https://www.vosa.gov.uk/R/2001/018)

Gearbox & drivetrain problems

- **Total manual gearbox failure** is common. The common symptoms are an excessively notchy gearchange, a noisy gearbox and/or oil leaks.
- **Clutches** are prone to severe wear if the vehicle has been used for towing, and they can be expensive to replace. Clutch master and slave cylinders are a common failure item, too, along with the wimpy bracket that the slave is mounted on.



- The **Steptronic automatic gearbox** (which is built by Nissan-subsidiary Jatco) gives major grief. Called the Jatco JF506E, it is fitted to the 2.5 litre petrol and 2.2 diesel. Total failure anytime from 60,000km is commonplace.

This gearbox wasn't a rock of stability to start with, and things haven't improved with age. Using one of these transmissions for significant amounts of towing all but guarantees expensive failure (check for scratches on the towball).

Typical symptoms of problems with these transmissions are a delay when engaging gears, slippage (the engine revs rise but the vehicle doesn't go much faster), loss of gears, jerking between gear changes, internal noises and vibration at low speed. Fault warnings will also display on the dashboard.

JF506E problems tend to take three forms: electronic, electrical and internal. On early vehicles (around 2002-2004), the transmission, which is electronically controlled, wasn't programmed correctly at the factory. This led to a number of problems. Left unfixed, these problems could quickly wreck the transmission. Therefore, the programming was often updated after the vehicle left the factory.



Electrical components, especially solenoids, are a major cause of grief on these transmissions. Typical symptoms of solenoid problems are a difficulty selecting some gears when cold, or jerky gearshifts when cold. Usually 3rd, 4th and 5th go first. If you're very lucky, simply replacing the pressure-control solenoid (which can be accessed without removing the transmission) will solve many problems.

However, there are a total of nine solenoids on this transmission: diagnosis and replacement requires an expert.

Internal failure is very common on higher mileage versions of these transmissions, especially early models.

If you can't select reverse gear, if you lose third, fourth or fifth gears, if there's a noticeable delay before anything happens when you shift from first to reverse and back again, if the shift from second to third is rough, or if there's a noticeable delay before the transmission goes into fourth or fifth gear, if there's a whining or rattling noise from the transmission, the chances are the transmission is stuffed and will require a very expensive overhaul.



Later versions (2005-on) were sometimes modified, but these modifications delayed the failure rather than solving the inherent problems. The bottom line is: many internal components on these transmissions are simply too lightweight for the job.

This transmission is also prone to failure caused by overheating, even during normal operation. For this reason, the use of one of these transmissions for towing is likely to end in tears.

These transmissions require expert service and it is generally inadvisable to take them to a regular garage for servicing.

It is important that the transmission is serviced: if the transmission fluid drops below minimum, failure due to overheating is likely. The transmission fluid requires replacement every 40,000km, and this job is by no means as easy as it sounds. Jatco, the company that built the transmission, advises that it's critical that the correct amount of the correct fluid is added.

The problem is, the gearbox fluid level needs to be checked at the correct temperature, and this requires diagnostic equipment that most owners and some garages don't have.



This transmission requires different transmission fluid (LRN-402) to other Land Rover vehicles, and using the wrong fluid can harm the transmission. As if that wasn't bad enough, the transfer case is cooled via an oil cooler hooked up to the rest of the cooling system. When the coolant fluid is changed, it's easy for air locks to form in the thin pipes linking the oil cooler to the main radiator. There are bleed nipples for the oil cooler, but they are a hassle to locate and operate. Many garages don't know they exist.

If bubbles block the oil cooler, the transfer case, transmission and sometimes the engine itself can overheat, with disastrous consequences.

Unwary mechanics can damage the transmission through ignorance: on the back of the transmission, above the driveshaft, is a 19mm special-torx bolt. Mechanics sometimes remove this bolt, thinking that it's the oil level plug. Unfortunately, this plug actually holds the internal brake band in place. If this plug is removed, the transmission will instantly lose reverse gear and the transmission will need to be removed and stripped to solve the problem.



The actual level plug is on the bottom of the transmission and is covered by a 5mm Allen-head bolt.

- The viscous coupling (fitted inline with the rear driveshaft) often dies young. It's expensive of course, but if not replaced in time it trashes the transfer case and/or rear differential.

The viscous coupling hanger bearings almost invariably need replacing at the same time. The easiest test of the viscous coupling is to drive the vehicle forward at a low speed and turn the steering wheel from lock to lock. A failed viscous coupling will cause the transmission to wind up, which has the effect of gently bringing the vehicle to a halt as if the handbrake had been lightly applied. The tyres will often show signs of unusual wear as well. If there's the slightest doubt about the viscous coupling, it must be replaced, or the resultant damage will be horrific:

- The transfer case – called the Intermediate Reduction Drive (IRD) on the Freelander – is a common failure point. The problem is usually caused by seizure of the viscous coupling unit on the driveshaft. This causes the transmission to wind up, and the IRD is the part that breaks first. The IRD is very expensive to replace and secondhand versions are a poor option.



If the IRD is fitted without replacing the seized viscous coupling, then the IRD will re-fail within a short time. The oil in the IRD needs replacing roughly every 20,000km, and failure to change the oil will wreck the unit. Whining is a sure sign of impending doom. However, a vibration from the transmission at speed may simply be a broken upper support bracket at the transfer case.

- The rear differential commonly fails, at great expense. The symptom is a whining or rumbling from the rear while driving. Differential failure may also be caused by a seizure of the viscous coupling unit on the driveshaft. There are two rear differentials fitted to the Freelander: the earlier version is the worst. After repeated failures a stronger replacement was fitted. However, the later differential is still prone to failure. As with the transfer case, if the seized viscous coupling is not replaced, the problem will recur. The oil in the differential needs replacing roughly every 20,000km, and failure to change the oil will wreck the unit. There's no drain plug, so the backing plate must be removed or the oil sucked out through the filler plug.



- **Driveshaft bearings** can fail at very low mileages. Noise from the driveshafts may also be worn hanger support bearings.
- **Hill descent control** dies young on many versions. This problem is often caused by a failure of the ABS unit (see *brake and safety problems*).
- Freelanders have a heavy appetite for front tyres, due to the poor design of the four-wheel drive system. Later models are better, but only by comparison.

Steering & suspension problems

- Dysfunctional **power steering** is common. The power steering reservoir tends to leak from the bottom hose. This is a hassly job due to access problems. The steering pump also dies. Please note that there are multiple versions of the Freelander steering pump, and they're generally not interchangeable. The steering rack itself is also fairly prone to problems, and they're not always obvious. Even if the rack doesn't leak a drop, the torque collar sometimes comes adrift inside and the rack begins to behave erratically.

You're likely to get heavy steering at parking and overly light steering at speed. There may also be a screech as you turn in one direction.



Complete rack replacement is the only option. Please note that there are also several different versions of the Freelander steering rack, and they're generally not interchangeable. However, a slight noise when turning at low speeds may be simply caused by vibration of the power steering pipes.

- **Suspension damage** is common if the vehicle has been used on rough roads or offroad.
- Typical front suspension failure points are the lower arm bushes, anti-roll bar link arms and mounting bushes, steering rack ends and struts.
- Typical rear suspension failure points are the rear trailing arm bushes, rear inner & outer lower link bushes, rear adjusting link bushes, together with the rear shock absorbers. A knocking from the back of the vehicle is likely to be broken differential mounts.
- Unevenly worn or scrubbed tyres suggests that the rear driveshaft viscous coupling is dead. Viscous coupling failure will wreck large parts of the drivetrain (*see drivetrain problems above*).
- Road noise is often the result of suspension bush wear. Low profile tyres also compromise the ride quality and produce noise on rough road surfaces.



However, the problem may also be worn wheel bearings:

- Wheel bearings are frequently worn out and it's not always obvious when you jack up the wheel and spin or wobble it. If in doubt, you need to jack up **all four wheels at once** and get someone to start the engine and run through the gears while you crouch near each wheel in turn. Worn wheel bearings can then be easily heard. However, it's important that the driver doesn't use the brakes to slow the wheels down after the test is done, or it may confuse the ABS system and cause error messages to be displayed. Just let the wheels spin to a halt on their own. It's also worth noting that it's sometimes hard to distinguish between wheel bearing noise and driveshaft noise. Moreover, both the wheel and driveshaft bearings are often worn out at the same time.

- On early models, a creak from the rear end while cornering at slow speeds means the rear subframe is loose in its mountings. This problem was the subject of a recall (see below), which means it's Land Rover's problem, not yours.

Some garages were unaware of the recall and simply welded the rear subframe in place, which is effective, but not an ideal solution.



SAFETY RECALL

 **Freelander models built between 12 & 29 August 2003** • The rear subframe may not be correctly fastened to the body and could potentially come loose.

VIN numbers:

SALLNABE13A286419–SALLNABG23A289164

Google  VOSA UK [R/2004/165](https://www.vosa.gov.uk/R/2004/165)

Brake & safety problems

- Front brakes can bind on early versions.
- The handbrake cables and adjusters can bind on all versions.
- The front brake lines (under the plastic front guards) sometimes rust.
- The airbag control ECU is prone to failure due to receiving corrupt calibration data and the symptom is the airbag warning light on.

Replacement is often the only option, although it's wise to check the various connections to make sure the problem is not simply a loose wire. The ECU is on the transmission tunnel under the heater box below the dashboard. Theoretically, getting the ECU out requires dashboard removal, but many



mechanics instead discreetly cut the carpet to get to the ECU. Please note also that this problem may be triggered by other warning systems within the vehicle.

- The ABS unit is prone to both electronic and mechanical problems. The Wabco ABS unit combines the ECU, pump & modulators and also handles the Hill Descent Control. The ABS wheel sensors die with age. If the ABS warning light is on, the problem may be any or all of the above. However if the ABS/ Hill Descent Control warning light is on and the Hill Descent Control is not working, the chances are that the problem is the main ABS unit, which will require replacement, probably at great expense. One frequent mechanical problem in the ABS/Hill Descent Control unit is a sticky shuttle valve. Occasionally this can be freed by taking the vehicle into sand or mud and applying the brakes a few times. Worth a shot. Before you write off the ABS unit, it's also worth checking that the Hill Descent Control switch and wires are functioning correctly. A defective brake pedal position switch will also cause the ABS warning light to illuminate.

- See our general airbag and ABS warning at the end of this review.



SAFETY RECALL

 **Freelander models built between 1 October 1997 & 28 February 2001** • The hand-brake may self release.

VIN numbers: not disclosed.

Google  VOSA UK [R/2001/107](#)

SAFETY RECALL

 **Freelander models built between December 1997 & July 2000** • The child restraint anchor fitting was installed upside down and may come off in use.

VIN numbers: not disclosed.

Google  VOSA UK [2000/4427](#)

SAFETY RECALL

 **Freelander models built between 26 August & 1 October 2004** • The passenger airbag may not have been manufactured properly and may fail to operate properly in a collision.

VIN numbers:

SALLNFAE85A449222 – SALLNABE85A456738

Google  VOSA UK [R/2004/184](#)



Body problems

- The **front chassis cracks** around the chassis rails on early versions (later versions were strengthened to prevent this problem). All versions before 2004 crack around the rear suspension attachment points if the rear subframe issue is not addressed (see *suspension problems*).
- **Underbody damage** is common if the vehicle has been used on rough roads or offroad.

Interior problems

- **Air conditioning** dies young and may be very expensive to fix.
- **The alarm remote and central locking system were something of a bad joke from new.** Many owners never got the system working reliably for any length of time. Sometimes the problem is the remote, sometimes the problem is the door locks and sometimes the problem is the central locking ECU, or a combination of the three, at random.
- **Heater failure** is common and may also be a symptom of a major cooling system/head gasket problem (an overheating engine – especially one with a leaking head gasket – will pressurise the cooling system, and the Freelander's cheap and



nasty heater matrix is the weakest link in an already fairly weak system). The heater matrix then dumps its contents onto the floor of the cab. This is a major repair, because the heater matrix is located deep inside the centre of the dashboard. In hot climates some people just block off the heater. However, many owners underestimate how important a heater can be when driving in the outback at night.

Bear in mind also that the heater is part of the cooling system; a leaking heater allows the cooling system to depressurise and therefore potentially overheat or exacerbate a system that is already overheating.

- Water leaks into the vehicle are common, especially from the sunroof, tailgate and softtops. The water tends to collect in the rear of the vehicle, but the condensation will gradually rot out the entire interior and play havoc with the electrics. It's worth checking the tool compartment hatch in the rear floor for water. If it's wet, the rear tailgate seal needs replacing, and maybe other seals as well. The rear door seals die young, especially on three-door versions.



- When you operate the tailgate handle, the window should drop about 10mm and then rise again automatically when the tailgate closes. If this doesn't happen, the electric motor and/or wiring is faulty. Expensive, of course. If the window goes up and down at random, the multi function control module is defective.
- Softtops on convertible versions are fairly fragile: the hood splits and the side windows go cloudy. These hoods are expensive to replace.
- The sunroof often jams open, due to the plastic rail breaking and distorting.
- The electric windows rarely work properly for long.
- The electric clock display breaks up, meaning you can't read the time.
- The **stereo fascia** sagged from new on early models
- **Dashboards** warp horribly in the sun.
- The windscreen demister was only marginal on early versions even when new and is often dead by now, often due to fan failure.
- The driver's seat back sometimes becomes insecure, which you can check by wobbling it. *See recall below.*



SAFETY RECALL

 **Freelander models built between 1 August 2000 & 28 February 2001** • The front seat backrest may not latch properly after using the seat tip lever, and could attempt to fold forward if the vehicle stops suddenly.

- **VIN numbers:** 1A578669 – 1A599999;
1A300000 – 1A320519
- Google  VOSA UK [R/2001/017](#)

SAFETY RECALL

 **Freelander models built between 1 November 2000 & 30 April 2005** • The child safety lock on the left rear door may fail.

- **VIN numbers:**
SALLNABE82A00225225–SALLNABE82A00238171
SALLNABH21A300642–SALLNFBE85A486387
- Google  VOSA UK [R/2004/076](#) and
VOSA UK [R/2005/083](#)



Electrical problems

SAFETY RECALL

 **Freelander petrol models built between 7 July 2000 & 18 March 2002** • Pin 5 of the diagnostic socket was not fitted with a ground. A pin must be fitted to position 5 and wired to earth.

- **VIN numbers:** 1A 576764 – 2A 397466
- Google  VOSA UK [R/2002/041](#)
- **Chronic electronic nightmares come standard with some versions of these cars**





Safety Summary



EuroNCAP crashtests

This rating is not nearly as good as it seems and applies only to models after 2002.

The Freelander got just 38 out of a possible 100 in its head-on crashtest.

The Freelander's reasonable side-impact rating (72) meant an acceptable overall result, although the good side-impact result has got more to do with the height of the vehicle than with good crash impact design (EuroNCAP testers run a ram into the side of the vehicle. Because this ram is about average car height, if the vehicle being tested is higher than normal, then the ram tends to pass underneath, thereby sparing passengers the impact).

In real life accidents, larger vehicles usually do far better than smaller vehicles. (A classic 1960s Mini weighs about 700kg and a recent Range Rover weighs about 2169kg. **This vehicle weighs about 1600kg, depending on the model**). *See also our comments in the links page that follows this review.*





Tech Specs

VIN PLATE LOCATION: On the passenger side of the dashboard, designed to be viewed from the outside through the windscreen

ENGINE TYPE & SIZE:

(petrol)

- **1.8** K-series 1796cc OHC EFI
- **2.5** KV V6 2497cc DOHC 24v MPI

(diesel)

- **2.0** L-series 20T 1998cc SOHC EFI *or*
TD4 1951cc DOHC 16v turbo

RECOMMENDED FUEL/S: **(petrol)** Premium

HOW MUCH FUEL?: Realistic urban averages:

(petrol)

- **1.8** 13.5 litres/100km • 7.4 km/litre • 21 mpg
- **2.5** 17.5 litres/100km • 5.7 km/litre • 16 mpg

(diesel)

- **2.0** 9.1 litres/100km • 11 km/litre • 31 mpg



Safety

PROPER SEATBELTS THROUGHOUT: Yes
(However, remember that the Freelander seats only four)

PROPER SPARE TYRE: Yes

ANTI-SKID BRAKING (ABS): Standard

AIRBAGS: Dual standard, most models. A few have only a driver bag.

ELECTRONIC STABILITY CONTROL (ESC):
No

REVERSING CAMERA: No



.



making sense of this review

Note: this PDF review is designed to be read on your computer. Obviously, the online links within this review will only work if you're viewing this PDF onscreen with your computer hooked up to the internet.

1) We suggest you read this page carefully if you're having trouble understanding the review. If you're frantic and need a quick confirmation that you're making the right car-buying decision, go straight to the 'Quick Summary' section on the front page of your review.

Here's the 'Quick Summary' section on the front page of your review.



2) The rest of the review is there to explain why we make our recommendation in the 'Quick Summary' section. Don't be surprised if we make a negative recommendation: we try and steer buyers away from vehicle purchases that are likely to end in tears.

3) Buying a car is a complex and confusing process. For this reason **we recommend that you calm down and read our supporting articles as well as the review itself**, so that you can see where we're coming from.

4) We especially recommend you click on the blue link below to read our article: ['How to Use These Reviews'](#).

5) If you're buying secondhand, we recommend you watch our free video: ['The Five Minute Car Check'](#).

6) There are a number of really useful supporting articles available free from our website. You can access these by simply clicking on the name of the article on the 'links' page that follows the review.

7) If you're still horribly confused: [contact us](#), but please have some compassion for our overworked support staff: most of the answers you need are already supplied within this review and the free articles on our website.



Enjoy!



Official name: Land Rover PLC

Brands: Land Rover, Range Rover.

Formerly owned by: Rover, British Leyland, BMW, then Ford.

Owned by: Tata Motors.

Current situation: Originally farm vehicles, Land Rovers are now a luxury brand. Under Ford ownership, efficiency improved but not quality: despite brilliant offroad ability, Land Rovers are generally overpriced, poorly built and unreliable. After years of losses (which contributed to Ford's near-bankruptcy), the Land Rover company made a small profit and was sold to Indian-based Tata Motors. Land-Rover is currently profitable, but much of this profit comes from China and is exceedingly vulnerable to economic downturn there.

Chances of survival: moderate.

Luxury carmakers are exceedingly vulnerable to economic slow-downs and Land Rover sales are reliant on the world being full of wealthy yuppies. Tata Motors is currently rapidly expanding its manufacturing capacity in order to meet high demand from China. This is a risky strategy, given the precarious state of the global economy. If things go bad in the key market of China, Tata is likely to join the long list of companies that burned their fingers on this iconic brand •



A brief commentary on Land Rover



IN 1948 the first Land Rover rolled off the assembly line. Conceptually based on the original American army jeep, the Land Rover was better suited to English conditions; it had a small, fuel economic engine and used existing Rover company parts.

After World War II, steel was in short supply but aluminium, no longer needed for fighter aircraft, was freely available. That's why much of the original Land Rover body was built using aluminium. Aside from saving weight, the aluminium didn't rust, so it became a permanent feature on many Land Rover models.

Even from the beginning, Land Rovers were noted for offroad ability; they were, and remain, class-leading. On the road, early Land Rovers were unpleasant, with their small, noisy engines and roly-poly handling. It was many years before the power of Land Rover's standard engines matched the needs of the owners, which is why many older Land Rovers have had DIY engine upgrades.



With the onslaught of cheap, reliable Japanese four-wheel drives, Land Rovers seemed as doomed as the rest of the British motor industry. However, the advent of the Range Rover and its offspring – the Discovery, saved the marque.





Overnight, Land Rover became a luxury car brand, like Rolls-Royce. Land Rovers and Range Rovers be-

came the preferred means of transport for aristocrats, stockbrokers and drug dealers alike.

Older Land Rovers – the ones that are actually used offroad by people who aren't yuppies – never really die. That has been their traditional strength; somehow or other, older Land Rovers almost always limp home. Which, by the way, doesn't mean that Land Rovers are, or have ever been, especially reliable. They're more like a troubled marriage that is continually patched up just as it approaches disintegration.

It's worse on the newer models: virtually all modern Land Rover models suffer from chronic unreliability combined with high repair costs. The BBC's *TopGear* magazine said it all: "If [there was] a formula that combined price with customer satisfaction, then the Range Rover would come stone last...It gets a 'very poor' rating in just about every single department of reliability."

We still love Land Rovers. They have a certain style and character that you'll rarely find in a Japanese offroader. They are also among the world's best offroad vehicles, when working. We just wish that the Land Rover people could make them reliable as well •



Dozens of useful additional articles for free!

Just click on the name of an article from the list below

(you need to be viewing this page on your computer and be connected to the internet for this to work).

Before You Buy

- Bargain Hunting
- How To Use These Reviews
- The Five Minute Car Check
- Finance
- Buying New
- Depreciation in Australia
- Depreciation in New Zealand
- Depreciation in the UK
- Insurance
- Types of Vehicles
- Japanese Secondhand Imports
- Cabriolets & Convertibles
- Yuppie Four-wheel Drives
- Hybrids
- British Cars
- European Cars
- German Cars
- Classic Cars
- Luxury Cars

Ownership Issues

- Automatics & CVT Transmissions
- A Question of Timing - timing belts
- Keeping It Cool
- Know Your Battery
- Tyresome Foolishness
- Diesels
- CNG & LPG
- Turbochargers & Superchargers

Safety

- Playing it Safe - vehicle safety features

- Making Sense of Crashtests
- Cars 1970-88
- Vans & Safety
- Four-wheel Drives & Safety
- Classic Cars & Safety
- A Tragic Lack of Restraint - seatbelts
- The Seven Deadly Sins - the causes of road crashes
- A Comedy of Errors - road safety ads don't work
- A Fine Mess - why fines don't work
- Calming the Madness - good road design can save lives
- That Sleep of Death - driver fatigue
- Victims of Circumstance - how you live affects how you die
- When a Phone Box Pulls Out In Front of You

Cars & The World We Live In

- A Long Way From Paradise
- The Dream Merchants
- Women & Cars
- Cars & Other Dysfunctional Relationships - by Germaine Greer
- The Chinese Bubble
- Cars & Nazis
- It's Not Easy Being Green
- The Emperor's New World
- The Emperor's New Car

The Meaning of Life

- Dictionary of Car Terms



Blown head gasket warning

Modern engines work hard. Because of this, they tend to get hot and frequently 'blow their top', especially if the engine has been overheated or run without fresh antifreeze. Head gaskets may be very expensive to fix and if left unfixed you'll probably end up broken down at the side of the road. Worse, blown head gaskets sometimes lead to total engine failure.

The symptoms of a blown head gasket are mysterious coolant loss, sometimes accompanied by rough running and overheating, clouds of white steam coming from the exhaust, oil in the water, water in the oil, and/or white goo under the oil filler cap (see picture opposite). You should also lift out the oil dipstick. If the oil is the colour of the white goo in the middle of the oil filler cap in the picture, you have a cracked cylinder head and/or blown head gasket. You should also be suspicious about any vehicle with a heater that leaks coolant into the interior of the car. A leaking heater is sometimes a symptom of a head gasket problem. So is a blown or leaking radiator or its hoses.



ABS & airbag warning

- Both the ABS (anti-skid braking) and airbag warning lights should go on and then off when you first start the vehicle. If this does not happen, the vehicle may require a major, extremely expensive repair immediately (if either the ABS or airbag warning lights do not go on at all, someone's probably disconnected them to hide the fact that the ABS or airbag system is faulty). If either warning light comes on while you are driving, this may mean a serious malfunction in the vehicle's safety systems, and the vehicle should not be driven, let alone purchased.

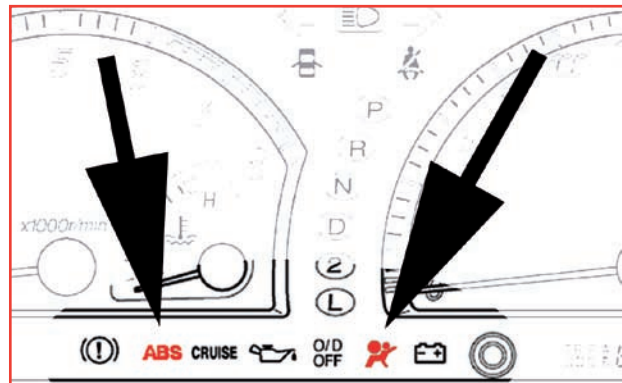

Automatic transmission warning

- Automatic transmissions that do not shift smoothly during a test drive are probably not long of this earth. Also, with the vehicle at normal operating temperature (so that the engine is not idling too fast) put the handbrake on and try switching the gear selector between forward and reverse – this should happen quickly and smoothly without any clunk – if not, suspect big repair bills in the near future.

Note: the advice below may not apply on some modern cars, because there may be no dipstick to check. For further information, see our articles on automatic transmissions and CVT transmissions in the links page (one page back).

With the transmission in neutral and the engine running at normal operating temperature, lift out the transmission dipstick, wipe it clean, put it back in and then remove it again. The automatic transmission fluid should be a happy cherry red colour & should be within the marked area on the transmission dipstick – if it's not, abuse and/or neglect is pretty likely and the vehicle should be avoided!

