

CARBIDE TIPPED SPECIALS QUOTE FORM - FAX TO 941-739-2827

LEXINGTON MANUFACTURES QUALITY SPECIALS TO MEET OUR CUSTOMERS' NEEDS. BELOW IS INFORMATION NEEDED TO QUOTE SPECIALS.

Name _____ Phone _____

Company _____ Fax _____

Full Address _____

Material Being Cut _____ Quantities _____

CARBIDE TIPPED - SHANK TYPE TOOLS

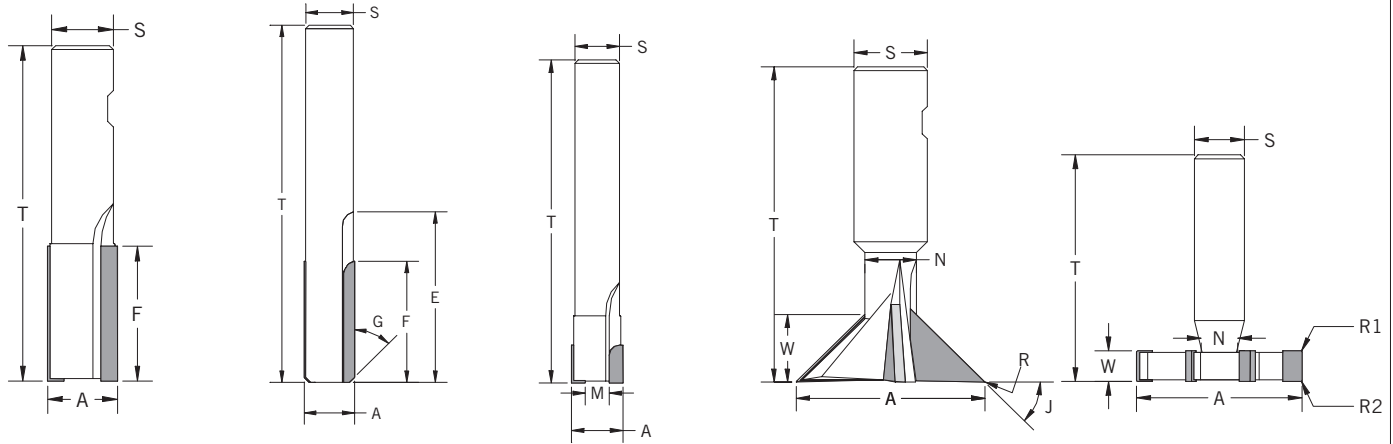

END MILL

REAMER

COUNTERBORE

DOVETAIL

KEYSEAT

BODY OF TOOL

T= _____ Overall Length S= _____ Shank Diameter A= _____ Major Diameter

FLUTES

E= _____ Flute Length F= _____ Carbide Length

G= _____ ° Chamfer Angle

Straight Flutes

Right Hand Cutting

Left Hand Cutting

Number of Flutes _____

Right Hand Spiral _____ °

Left Hand Spiral _____ °

IF PILOTED

Head Diam. _____

Head Length _____

M= Min. Cutting Diam. _____

IF STEP REAMER

(Also see pages 80-82) Minor Diam. _____ Step Length _____ Step Angle _____ °

IF KEYSEAT

W= _____ Width

Straight Tooth

R1= _____ Radius/Chamfer

N= _____ Neck Diameter

Staggered Tooth

R2= _____ Radius/Chamfer

IF DOVETAIL

N= _____ Neck Diam. J= _____ ° Angle R= _____ Radius W= _____ Width

CARBIDE TIPPED - ARBOR TYPE TOOLS

D= _____ Cutter Diameter

W= _____ Cutter Width

A= _____ Arbor Hole Diam.

N= _____ # of Teeth

H= _____ Hub Diameter

K= _____ Keyway Size

R1= _____ Radius/Chamfer

R2= _____ Radius/Chamfer

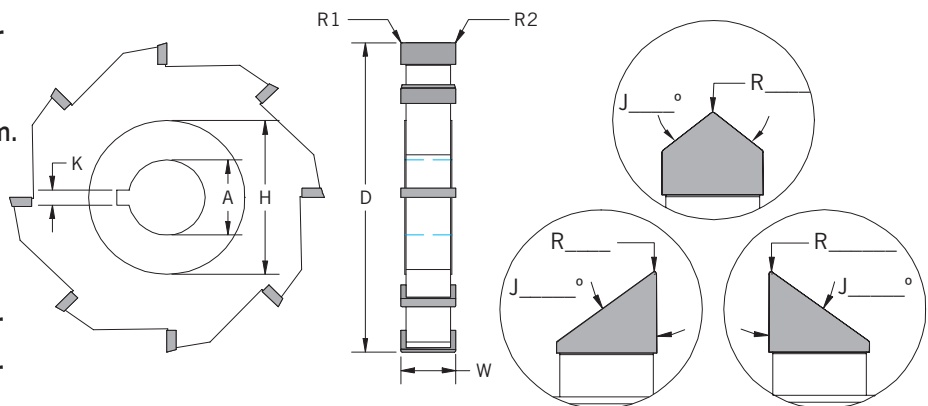

Straight Tooth

Straight Stagger

Herringbone Stagger

MILLING CUTTER

SLITTING SAW

ANGLE CUTTER

(Fill in "J" & "R")

LEXINGTON CUTTER, INC. • sales@lexingtoncutter.com • Phone 800-882-2627 • Fax 800-882-3637