

Alfastret 
marine

ENERGY 183

USER GUIDE



Contents page

1 WELCOME ON BOARD	4	6.1.1 Protection of the electric motor	37
1.1 About the manual	8	6.1.2 Torqeedo Cruise 2.0R technical data	37
1.1.1 Warning signs and symbols	8	6.1.3 Plan of operating elements	38
1.2 Other manufacturer's user guides	8	6.1.4 Remote throttle with integrated display and magnetic key	38
1.3 Your responsibilities	8	6.1.5 Setting up the battery charge indicator	39
1.3.1 Navigation ability	9	6.1.6 Trouble shooting	42
1.3.2 Registration of the vessel	9	6.1.7 Pylon	43
1.3.3 Vessel categories	9	6.1.8 Changing the propeller	43
1.3.4 Weather conditions	10	7 HYDRAULICS	44
1.3.5 General navigation safety rules	11	7.1 Construction	44
1.3.6 Planning the navigational route	11	7.2 Hydraulic aggregate	46
1.4 Supplier's responsibilities	12	7.3 Hydraulic telescopic cylinders	47
1.4.1 Warranty period	12	7.4 Return mechanism	47
2 THE COMMON SENSE PRINCIPLE	13	7.5 Steering mechanism	48
3 SAFETY	14	8 BEFORE THE NAVIGATION	48
3.1 General safety measures	14	8.1 Transport and lifting of the vessel	48
3.2 Safe navigation	14	8.1.1 Lifting the vessel	49
3.3 Obligatory equipment	15	8.1.2 Towing the vessel	49
3.3.1 Life jackets	16	8.2 Lifting and lowering the roof	49
3.3.2 Portable fire extinguisher	16	8.3 Embarking the vessel	51
3.3.3 Whistle, horn	16	8.4 Fuel quantity and navigational length	51
3.3.4 Visual warning tools	16	8.5 Navigation plan	51
3.4 Recommended equipment	16	8.6 Nautical charts	52
3.5 Rescue equipment	17	8.7 Weather forecast	52
3.6 Emergency situations	17	8.8 Measures before departure	52
3.7 Phone numbers for emergency calls	20	9 DURING THE NAVIGATION	52
3.8 Problems with manoeuvring the vessel	21	9.1 Position of the passengers during the navigation	52
4 TECHNICAL INFORMATION ABOUT THE VESSEL	21	9.2 Motor angle	53
4.1 Dimensions	21	9.3 Safety switch for shutting down the motor	53
4.2 Speed and autonomy	23	9.4 Ignition	54
4.3 Carrying capacity	24	9.5 Observing the surroundings during navigation	55
4.4 Stability	24	9.6 Passenger safety	55
4.5 Motor power	24	9.7 Autonomy of the batteries	55
4.6 Hull identification number	25	9.8 Awareness and environment care	55
4.7 Manufacturer's certificates	26	10 AFTER THE NAVIGATION	56
4.8 International requirements	26	10.1 Arrival notice	56
4.9 Navigation and anchor lights	26	10.2 Stopping the motor	56
5 ELECTRICAL INSTALLATION	26	10.3 Vessel equipment care	56
5.1 Diagram of the vessel's electric circuits	28	10.4 Switching off the current-using equipment	56
5.2 Batteries	29	10.5 Vessel protection	56
5.3 Battery charge with the system voltage of 220V	30	11 MAINTENANCE	57
5.4 Battery charge with solar cells	30	11.1 Cleaning and servicing the vessel	57
5.5 Battery maintenance	34	11.2 Lifting the vessel	57
5.6 Fuses	34	11.3 Vessel and equipment protection	57
5.6.1 Fuse for moving the roof	35	11.4 Regular servicing	58
5.6.2 Fuses of other current-using components	35	11.5 Storing the vessel in winter	58
5.7 Switches for the current-using components	36	11.6 After the winter storage	59
6 MOTOR	36	12 SERVICING	60
6.1 Electrical motor	36		

1 WELCOME ON BOARD

Congratulations for becoming the owner of the vessel Energy-18. Alfastreet Marine greets you and welcomes you into the company of owners and lovers of vessels. Take your time to carefully read these guides and their attachments. This publication will help you to answer all the questions you might have regarding the vessel. In case you have additional questions, please contact the salesperson. Alfastreet wishes you to feel comfortable and safe on your vessel from the first experience onwards.

Please complete the chart below so that the important information about your vessel and its manufacturer shall be gathered in one place and quickly available when you need them.

Vessel model: _____

Vessel identification number: _____

Vessel registration number: _____

Serial number of propulsion aggregate: _____

Manufacturer's representative: _____

Representative's address: _____

Representative's telephone number : _____

Authorised service centre : _____

Authorised service centre's address : _____

Authorised service centre's telephone number: _____

NOTES:

Our contact information:

Alfastreet d.o.o. - Alfastreet MARINE
Partizanska 129, SI-6210 SEŽANA, SLOVENIA
tel. n.: +386 5 70 72 100
fax: +386 5 70 72 127
website: www.alfastreet-marine.si

Contact person:

Tjaša Luin Peric

email: tjasa.luin@alfastreet.si

tel. n.: + 386 5 70 72 123,

mobile: + 386 41 388 166

Technical support:

Dejan Ravbar

email: dejan.ravbar@alfastreet.si

tel. n.: +386 5 70 72 115

QR codes:

WEB page www.alfastreet-marine.si :



Energy18 user manual (in PDF):



Certificate of the vessel's suitability for the requirements of the boat design category C and D



Picture 1: Certificate of the vessel's suitability



Picture 2 Certificate of the vessel's suitability

1.1 About the manual

These guides offer important warnings about safety and your responsibility as the vessel's owner. All the information provided in this publication is based on the latest information available at the time of printing. Due to our policy of continuous product improvement, we reserve the right to apply changes at any time and without prior notice in the specification of the models as well as in case of cancellation of any models. Furthermore, we reserve the right to change the specifications, the components or additional equipment whenever and without any obligations to models produced prior the date of such changes. Alfastreet Marine recommends a periodical visit of our website www.alfastreet-marine.si, where you can find additional and new information as well as the FAQ section.

1.1.1 Warning signs and symbols

The manual also provides warning signs. These have different meanings and levels of importance, it is therefore necessary to carefully read the content of the three warning signs below.



1.2 Other manufacturer's user guides

The vessel Energy-18 features equipment and various components from different manufacturers. The equipment and the components are only mentioned in this manual as all the manuals, user guides, warranty statements and detailed information on the equipment and the components are collected in a special folder (Additional equipment). If you miss any document that you think should accompany the vessel, please contact your vendor or call Alfastreet d.o.o. on the phone number +386 5 70 72 100.

1.3 Your responsibilities

As the owner of the vessel and a participant in the traffic on water, you are responsible for the navigation safety, the traffic safety and the safety of the passengers on board. You should especially take into account how to:

- increase of the safety at sea,
- reduce your risk of collision and injuries at sea,
- increase your independence at sea,
- expand your navigation area,

1.3.1 Navigation ability

Reading, understanding and using this user guide is just as important as learning to adequately control the vessel. This publication IS NOT a course on safe navigation and is also NOT a manual on how to operate, how to anchor and how to tie the vessel. A safe control of the vessel requires more skills, knowledge and awareness than is required for driving a car or lorry.

As the driver, owner and user of the vessel you are responsible for it, therefore it is necessary to inform yourself on safety and complete a course on safe navigation. Furthermore, inform yourself on the correct handling of the vessel in case of emergency. As the vessel traffic in closed seas is denser, you should also learn the rules of operating, avoiding and manoeuvring the vessel.

1.3.2 Registration of the vessel

Every vessel needs to be included in the register before its first departure. This is carried out in the office authorised for the registration of vessels. In Slovenia, this can be done at the Maritime Directorate of the Republic of Slovenia. For further information about the registration you can contact the Directorate or visit their website http://www.up.gov.si/si/storitve/vpis_colnov/ . It is imperative that the registration is done before the first departure.

Apart from the registration in the country in which the vessel is most commonly used, it is also necessary, in the event of navigating into the seas of another country, to inform yourself on a possible additional registration of the vessel, as it is required by some countries. The easiest option to do this is at the office which issues the navigation permit.

1.3.3 Vessel categories

The vessels are divided into four categories, according to their navigation capacity in various weather conditions:

A. Ocean navigation area

Highest wind speed: over 40 knots (over 20.6 m/s)

Wave height: over 4m

The vessel can navigate in the ocean.

B. Offshore navigation area

Highest wind speed: up to 40 knots (up to 20.6 m/s)

Wave height: up to 4m

The vessel can navigate in the high seas.

C. Inshore navigation area

Highest wind speed: up to 27 knots (up to 13.9 m/s)

Wave height: up to 2m

The vessel can navigate in the coastal area, larger gulfs, lakes and rivers.

D. Sheltered coastal area

Highest wind speed: up to 15 knots (up to 7.7 m/s)

Wave height: up to 0.5m

The vessel can navigate in smaller lakes, rivers and canals.

Your vessel Energy 18 satisfies the requirements of the category C and D.

The information on the highest wind speed and wave height included in the above text do not mean that the vessel would sink above the mentioned wind and wave limits. The information means that you would be able to safely navigate with your vessel in such weather conditions. Nevertheless, it is necessary to inform yourself on the conditions at sea before the departure, in order to avoid storms or other inconveniences at sea. It is also necessary to be aware of any change of weather during the navigation, as bad weather, high waves etc. can catch you very quickly, which can seriously threaten your safety as well as the safety of your passengers.

1.3.4 Weather conditions:

Before and during the navigation you should pay special attention to the following:

- inform yourself on the weather forecast and weather conditions at sea before your departure from the marina,
- a sudden change in the wind speed or direction as well as in the wave height can signal a fast deterioration of the weather,
- if you notice a storm approaching, navigate immediately to the nearest marina or quay,
- if you are surprised by a storm during the navigation, make sure all passengers are seated and direct the prow towards the wind maintaining enough speed to slowly move forward,
- check if all passengers on board have an adequate life jacket,
- if you navigate into a dense fog, determine your position, lower your speed and warn other vessels of your presence,
- when a thunderstorm is approaching, it is very important to tie the vessel along the coast as quickly as possible and disembark. Do not stay in the water during the lightning, as that would increase your possibility of being struck.

Safety in water traffic

The water surface does not feature any road lanes, indicators or similar help found in road traffic. Therefore the vessel's conductor must be even more aware of all sides of the vessel and not just the direction of navigation.

Failure to consider safety rules and negligence can quickly lead to serious injuries of the people on board or even death, as the consequence of accidents.



1.3.5 General navigation safety rules

Always be aware of your surrounding during the navigation and follow these rules:

- Always conduct the vessel with an adequate speed, which ensures a safe navigation for all passengers on board,
- Always pay attention to the traffic in the direction of navigation as well as around the vessel, especially before you change the direction of navigation.
- Reduce the speed of the vessel, pay attention to its surrounding, not only the direction of navigation, and turn on the vessel's navigation lights when:
 - the visibility is reduced,
 - in turbulent water,
 - in dense traffic.
- Always depart after getting enough sleep or after enough rest. In case you fall asleep when controlling the vessel, you can cause it to sink or crash into another vessel or participant in the traffic on water. You are also fully responsible for the damage caused by falling asleep during the navigation.

The conductor of the vessel must always pay attention to the vessels approaching from all sides. He must also pay attention to the bathers, partly sunk wrecks and other objects in water which are dangerous to the navigation (trunks, reefs, shallows, strong currents, etc).

The passengers on your vessel rely on you to take care of their safety and the safety of the navigation by maintaining an adequate speed and by respecting the navigation safety rules. You should also make sure that you do not expose your passengers to danger with quick manoeuvres, such as turning, sudden increasing or reducing of the speed. During weather changes or reducing daylight that result in low visibility, you must adjust the speed of the vessel to the momentary navigational conditions. By doing so, you gain enough time and space to avoid danger.

1.3.6 Planning the navigational route

In order to avoid navigating in dangerous waters with potentially dangerous reefs, sunken objects, shallows, dangerous currents and similar perils, it is necessary to prepare, prior to your departure, a detailed **navigational route** which you plan to follow.

During the planning of the route you should use adequate navigational tools which you know how to use and understand their importance. You should also take into account the guidelines of experienced guides and sailors and consider the most appropriate time of navigation for your navigational route area (tide). In case of navigating in unknown waters, without knowing the possible dangers, navigate with low speed and carefully observe the surrounding area as well as the direction of navigation, in order to avoid any potentially dangerous situations.

Make sure that others know where you are.

Therefore, before departure inform your family members and friends about the following:

- the planned direction of your navigation,
- the envisaged date and time of return,
- the description of the vessel,

- the number of passengers on the vessel.

In case of emergency these information can be transferred to the coastal station or the rescue boat crew which will be sent to help you, thus, considerably increasing the possibilities of your rescue and limiting the possibilities of serious injuries of the passengers. It is also important to inform them about your arrival to the destination, as failure to do so could result in a false alarm!

1.4 Supplier's responsibilities

The supplier guarantees the vessel with the determined equipment, service and examination of the boat before the supply and at any time after the supply as well as the possibility of complaint in case of proven defects on the vessel. Furthermore, he offers an illustration and presentation of the safety requirements, signs, procedures and instruments as well as an explanation and, if necessary, an illustration of the basic procedures for controlling the vessel. The supplier also examines with the client all the information about the warranty, explains what to do in case of breakdowns and how to obtain a warranty service. Moreover, he provides the complete user guides.

If you do not receive all the equipment or if you have problems with the vessel and you wish file a warranty claim, call your supplier or the supplier of the defective component.

1.4.1 Warranty period

Alfastreet d.o.o. (Alfastreet Marine) guarantees to all the owners of the vessel Energy 18, who purchased the vessel through the manufacturer or his legal representative, to repair all defects and substitute the defected components of the vessel, which occurred within the warranty period. The said period for the vessel Energy 18 is of one year (12 months), with the exception of the components listed in the following chart, for which the manufactures guarantees a different warranty period.

Product	Warranty period	Note
Plastic	Osmosis for all polystyrene parts 5 years, for other defects 2 years	
Hydraulic roof	3 years	Polyurethane parts of the roof according to the above mentioned conditions
Gelcoat	2 years	
Batteries	1 year	Maintenance according to the manufacturer's guidelines (ENCLOSED)
Propulsion (electric or petrol motor)	1 year	Manufacturer's warranty and service
Propeller	1 year	Mechanical damages and wear are not covered by this warranty.
Radio with speakers	1 year	Manufacturer's warranty and service
Photocells	1 year	Manufacturer's warranty and service
Battery charger	1 year	Maintenance according to the manufacturer's guidelines (ENCLOSED)

The warranty claim can be filed only with the original receipt, validated by the manufacturer or his legal representative.

2 THE COMMON SENSE PRINCIPLE

Dear customer – user

The manufacturer, distributor, designer, constructor, boat examiner and others who contributed in any way to the realization of the vessel and writing of this manual, guarantee to have put the maximum effort into these extensive guides for the safe use of the vessel Energy 18 and to have included all possible situations and problems that you could encounter in the role of the owner and user of the vessel, both on land and on water. Nevertheless, there are various examples or series of events that were not described in this manual or that were described in a different form.

Therefore, all the above mentioned persons involved in the project of building your vessel appeal to you, to take into account when using your vessel not only the guides from this manual but also the very important PRINCIPLE OF COMMON SENSE! Navigation can be a fantastic and unique experience which can also lead to tragedies if the safety rules are not

respected. Always bear in mind to departure after enough sleep and rest and with responsibility towards yourself and the people around you.

This principle should be respected always and everywhere, but we would like to ask the users, to fully respect the said principle especially when using this vessel.

Always consider the safety of all the enthusiasts of water-related activities.

3 SAFETY

Your safety and the safety of your passengers depend on the way you operate with and maintain the vessel. Reading and understanding the entire manual is therefore necessary for anyone who shall operate the vessel, in order to achieve a safe navigation. It is also necessary to take into account all the additional guidelines provided by the manufacturer or the supplier. On top of that, you need to make sure that you understand the importance and function of all instruments and buttons featured on the dashboard of the vessel prior to your departure.

An incorrect use of the vessel is dangerous. The present chapter offers a description of the most important safety rules, which must be observed before, during and after the navigation.

3.1 General safety measures

Make sure that all passengers on board of the vessel are aware of and apply the basic safety measures and rules of this manual. The safety of the navigation begins by knowing the dangers which can occur during the navigation and by respecting all the safety rules and measures. Apart from the guidelines of this manual, you should also consider the notifications issued in the marinas, gulfs and destinations featured in the planned navigational route.

3.2 Safe navigation

Many boat accidents are often caused by lack of knowledge, failure to respect the safety rules and measures by the conductors of the vessels and their passengers. A correct handling of the vessel, a prompt identification of potential dangers and the application of the safety measures can help to avoid and prevent many dangerous situations.



Main safety guidelines:

- An incorrect use of the vessel is very dangerous! The conductor of the vessel must read and understand all the manuals enclosed with the vessel.
- The vessel's equipment must be in accordance to the local regulations and laws of the country in which we are navigating.
- When conducting the vessel, always attach the clip connected to the safety system for switching off the motor to yourself (the best option is to put it on the belt line of your pants). In the event of you falling into the water, this system will make sure that the motor is automatically switched off, thus preventing the uncontrolled navigation of the vessel.
- Never conduct the vessel under the influence of alcohol or other psychoactive substances (illegal drugs, sedatives, stimulants, strong drugs, etc.).
- During the navigation, you and your passengers should be seated on the sitting surfaces.
- During the navigation, it is forbidden to stand or sit on inappropriate places (the edge of the vessel, the motor lid, the roof). Failure to respect this guideline can lead to someone falling into the water or even drowning.
- Before switching on the vessel's motor, you must lift the motor's cover and make sure that the working space of the propeller is free of any foreign objects, which could hamper the functioning of the motor and present a danger during the navigation (branches, ropes, fishing nets...). You also need to check that the propeller isn't damaged in any way.
- Any use of open fire or sparkling objects that could start a fire on board of the vessel is forbidden.

3.3 Obligatory equipment

This chapter features a presentation of the equipment which is required by law and is obligatory on board of the vessel, as well as the recommended equipment. It is very important to regularly check the equipment on board and check the technical suitability of singular components.

According to the Maritime directorate of the Republic of Slovenia, the obligatory equipment for the navigation in the inshore and sheltered coastal area for vessels without cabins over 5m and vessels with cabin of up to 7m in length is:

- an anchor with a rope or chain for anchoring of at least 30m in length,
- three ropes for tying with the collective length of at least 40m and suitable strength,
- an auxiliary propulsion (motor or sails) or VHS radio station or three red parachute rockets,
- bailer of hand pump,
- lights and day signals according to the regulations on avoiding collisions at sea,
- a concave mirror (for speedboats used for water skiing),
- three red torches,
- a compass,

- life jackets of the same number as the persons on board the boat.

For more informations about rules and obligatory equipment, please consult your local authorities (Port authority, Ministry of Maritime Affairs).

3.3.1 Life jackets

If the boat is equipped with life jackets, their number and size must correspond to the number and sizes of the persons on board. Only life jackets with an adequate certificate can be used.

3.3.2 Portable fire extinguisher

The vessel can be (or, if required by law or local jurisdiction, it must be) equipped with a portable dry powder fire extinguisher, which needs to be periodically checked by an authorized person or organization.

3.3.3 Whistle, horn

On board the vessel you must keep a sound tool, such as a whistle or horn, in order to warn others of your presence when the visibility is reduced.

3.3.4 Visual warning tools

If you are navigating at sea, you must keep three warning tools on board, which can be used during the day or at night (three red torches or signal rockets). The signal tools must feature a suitable certificate, they must not be expired and they must be kept in a dry and dark space.

3.4 Recommended equipment

Along with the obligatory equipment required by law, it is recommended to keep on board the vessel the following objects:

- a first aid kit,
- maps of the planned navigational route,
- a compass,
- a GPS,
- a marine VHF radio,
- an emergency position indicating radio beacon (EPIRB),
- a hand pump,
- a mosquito repellent,
- several ropes,
- waterproof battery lights,
- replacement batteries for lights,
- replacing keys for the vessel's motor,
- the manual for the vessel's motor,

- motor oil,
- a toolbox with:
 - combined pliers,
 - a selection of open end spanners,
 - an electrical tape (insulating tape),
 - a hammer,
 - several replacement components (fuses, light bulbs, screws, etc.),
 - a replacement propeller.

3.5 Rescue equipment

Even very good swimmers can become quickly tired and drown due to exhaustion, hypothermia or both. Thanks to the rescue equipment, the person who fell into the water can keep himself above the surface of the water with considerably less effort and unnecessary use of body temperature. This raises the chances of survival significantly. The conductor of the vessel must make sure that there is one life jacket for each person on board. Before each navigation, he must also indicate to the passengers on board where the life jackets are and how to use them properly. The life jackets must be on easy reach. The best option would be if the life jackets would be worn by the passengers during the navigation. Before purchasing the life jackets, make sure that they feature all the certificates of suitability. It is also necessary to check at least once a year their floatation and look for any damages.



3.6 Emergency situations

In order to avoid navigating into dangerous areas, sunken wreckages, shallows, dangerous currents and similar, it is necessary to **plan a navigational route**, by using adequate nautical maps and navigational tools properly and by taking into account the guidelines of experienced conductors and sailors as well as the weather changes and the tide. If you navigate in unknown waters, reduce the speed of the navigation and pay attention to the surroundings in order to avoid collision with another vessel or any dangers in the water.

Important safety guidelines:

Before departure, inform your family and friends of the following:

- the planned direction of your navigation,
- the envisaged date and time of your return,
- the description of your vessel,
- the number of passengers on board.

In case of emergency, such information can be provided to the coastal station, for example, the harbour office, which would increase the chances of a prompt rescue.

A. First aid kit:

You must keep a complete first aid kit on board. During the navigation you will be situated a long distance from an ambulance station, therefore there should be at least two trained rescue workers on board, who have completed the first aid course.

B. Water rescue:

If a person falls into the water with below 20°C, there is a great chance that the person will drown due to hypothermia. Therefore it is very important to pull the person onto the vessel as soon as possible.

This can be done in the following ways:

- by returning to the person in the water,
- by calling the person in the water,
- by pulling the person out of the water and on board the vessel.

Returning to the person in the water

- inform everyone on board about the accident,
- carefully observe the person in the water,
- carefully navigate towards the person in the water,
- if the rescue takes place at night, make sure to direct as much light as possible towards the person in the water to maximise the person's visibility,
- throw a rescue ring to the person in the water, even if this person is already wearing a life jacket.

Calling the person in the water

- reduce the speed and navigate around the person in the water,
- approach the person in the water so that the person is on the windward side of the vessel,
- when you are close to the person in the water, switch off the motor to avoid any injuries of the person with the propeller.

Pulling the person in the water on board

- try to pull the person in the water towards the vessel with a paddle or rope,
- do not swim towards the person in the water, unless necessary,

- help the person in the water to get on board (the easiest way is across the stern),
- if the person in the water is injured or cannot reach the deck by himself, someone on board must put on a life jacket which is attached to the vessel with a safety rope and the said person picks up the injured person in the water,
- while the pulling the person on board, be extremely careful as the said person might have suffered injuries to the spine or other parts of the body.

C. Fire

Fire is a very serious accident which can occur on board, as the vessel can burn down quickly. If you do not manage to put out the fire in a few minutes, focus on your rescuing instead of on extinguishing the fire. Abandon the vessel. Keep the portable fire extinguishers at hand as the starting small fires can be put out quickly and easily. It is also important that the portable fire extinguishers on board are of a suitable type.

- Extinguish all smoking objects,
- switch off the motor, the fans, the ovens,
- if possible, throw the burning objects out of the vessel,
- if possible, direct the squirt of the extinguishing agent into the source of the fire and not the top of the flame,
- if the vessel features an automatic fire extinguishing system for its motor, wait for 15 minutes after the system's activation before you lift the cover of the motor. Keep the portable fire extinguisher at hand.
- Call for help,
- activate the digital call for help (GMDSS), if you have the necessary equipment on board,
- put on a lifebuoy and prepare to abandon the vessel.

D. Sinking, capsizing of the vessel

In case of sinking or capsizing of the vessel:

- try to switch off the motor and the electrical equipment before leaving the vessel,
- check if everyone on board is wearing properly fastened life jackets,
- check if all passengers managed to save themselves from the sinking vessel,
- if the vessel is sinking, stay near the vessel, try to board it and activate the help signal (signal rockets),
- in extreme cases, try to swim towards the shore. Do not forget that the shore is further than it seems and there is the possibility of drowning due to exhaustion during swimming.

E. Collision and flooding

In the event of collision with another vessel or object in the water or in the event of flooding:

- lower the speed of navigation to reduce the amount of water breaking into the vessel,
- switch on the water pump,

- use also the manual water pump,
- check if all passengers are on board and if anyone is injured,
- all passengers must put on the life jackets,
- activate the call for help,
- in the event of flooding, put a large cloth, clothing or similar into the hole from which the water is breaking into the vessel in order to stop the flooding. The best option is to put the cloth into the hole from the exterior side of the vessel.
- In the event of collision, it is necessary to file a report on the accident and notify the nearest coastal station.

F. Running aground

In the event of the ship running aground:

- check if the water is breaking into the vessel. In this event, put a cloth or piece of clothing into the hole before you try to push the vessel back into the water.
- Check for any visible damages to the body, the propulsion system or the system for turning the vessel.
- Determine if the water current and the wind will push the vessel further into land or if they will help to return the vessel into the water.
- Verify the depth of the water around the vessel and the type of floor (sand, stone). Move the vessel away from the spot of collision or running aground towards deep water, but only if this can be anywhere done safely without exposure to danger.
- Your vessel should be pulled only by a crew experienced in towing or by a vessel of adequate organizations and institutions (the harbor office, coastal station, marine police, military etc.). Recreational and sports vessels are not intended for towing other vessels.

G. Breakdown of the motor or the manoeuvring system

In the event of a breakdown of the motor or of the system for manoeuvring the vessel:

- switch off the vessel's motor immediately,
- anchor the vessel in order to prevent an uncontrolled navigation (with the current),
- check if you can fix the error by yourself. Consult the adequate manuals for descriptions on how to repair the breakdown.
- If you are not sure on how to repair the error on your own, activate the call for help.

3.7 Phone numbers for emergency calls

In the event of accidents, an emergency call can be made through the radio station, if you have it on board, or by phone on the following phone numbers:

- **080 10 88 ... contact centre for emergencies at sea**
- **112 contact centre for calls in distress 112**
- **113 police**

3.8 Problems with manoeuvring the vessel

The use of illegal drugs and/or alcohol hampers the safe conduction of the vessel and is also the most common cause of accidents with severe and tragic injuries. The influence of these substances increases in the strong sun, wind and waves, as well as other weather features and leads to irrational and too slow reactions to the dangers on water, resulting in an inevitable accident.

Therefore, it is very important that the person conducting the vessel is fully focused, sober, has had enough rest and is entirely concentrated on the navigation.

4 TECHNICAL INFORMATION ABOUT THE VESSEL

4.1 Dimensions

As can be seen from the following pictures, the dimensions of the vessel Energy 18 are:

- entire height with open roof 2.3 m
- entire height with closed roof 1.4 m
- height from the water line to the top of open roof 1.85 m
- height from the water line to the top of closed roof 1 m
- height from the water line to the top of the hull 0.82 m
- length 5.4 m
- width 2.25 m
- depth* 0.4 m
- max number of persons on board** 8 (but not over 700 kg)

* can change depending on the number of passengers and load on board the vessel.

** the carrying capacity is not only limited to the number of persons on board, but also to the collective weight of the passengers and the load on the vessel.

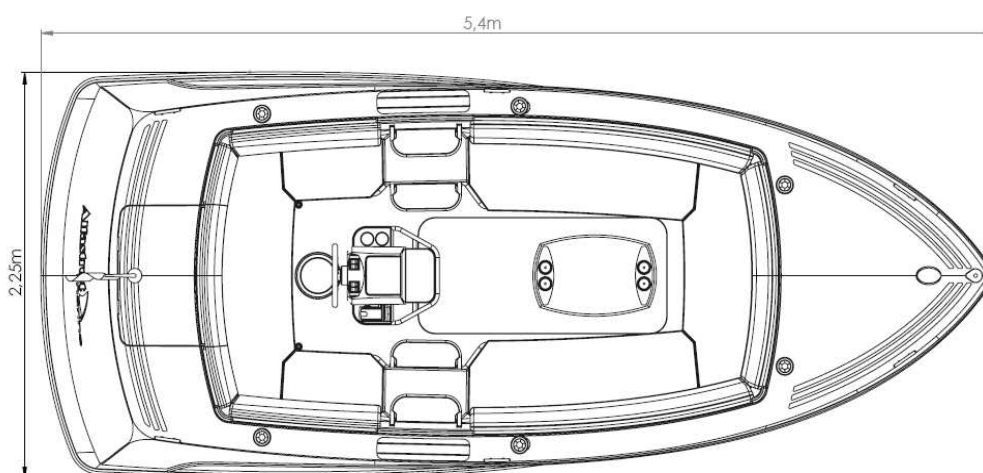

Picture 3: Dimensions – ground plan

Energy 18 – User Guide

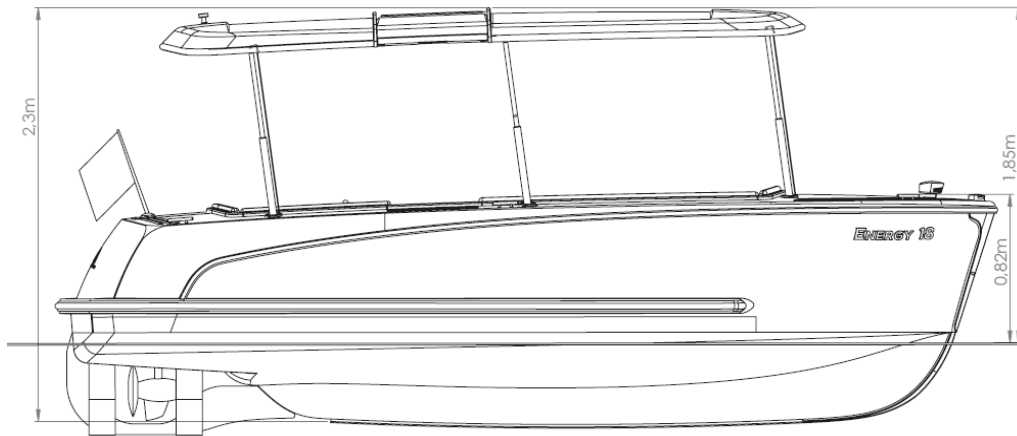

Picture 4: Dimensions – side with open roof

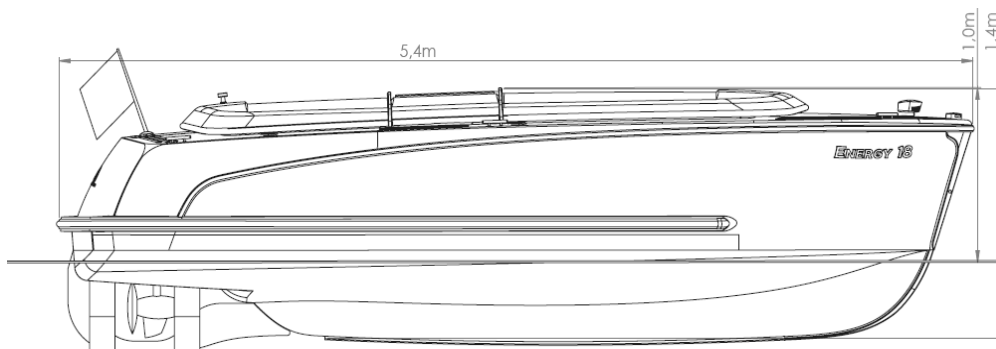

Picture 5: Dimensions – side with closed roof

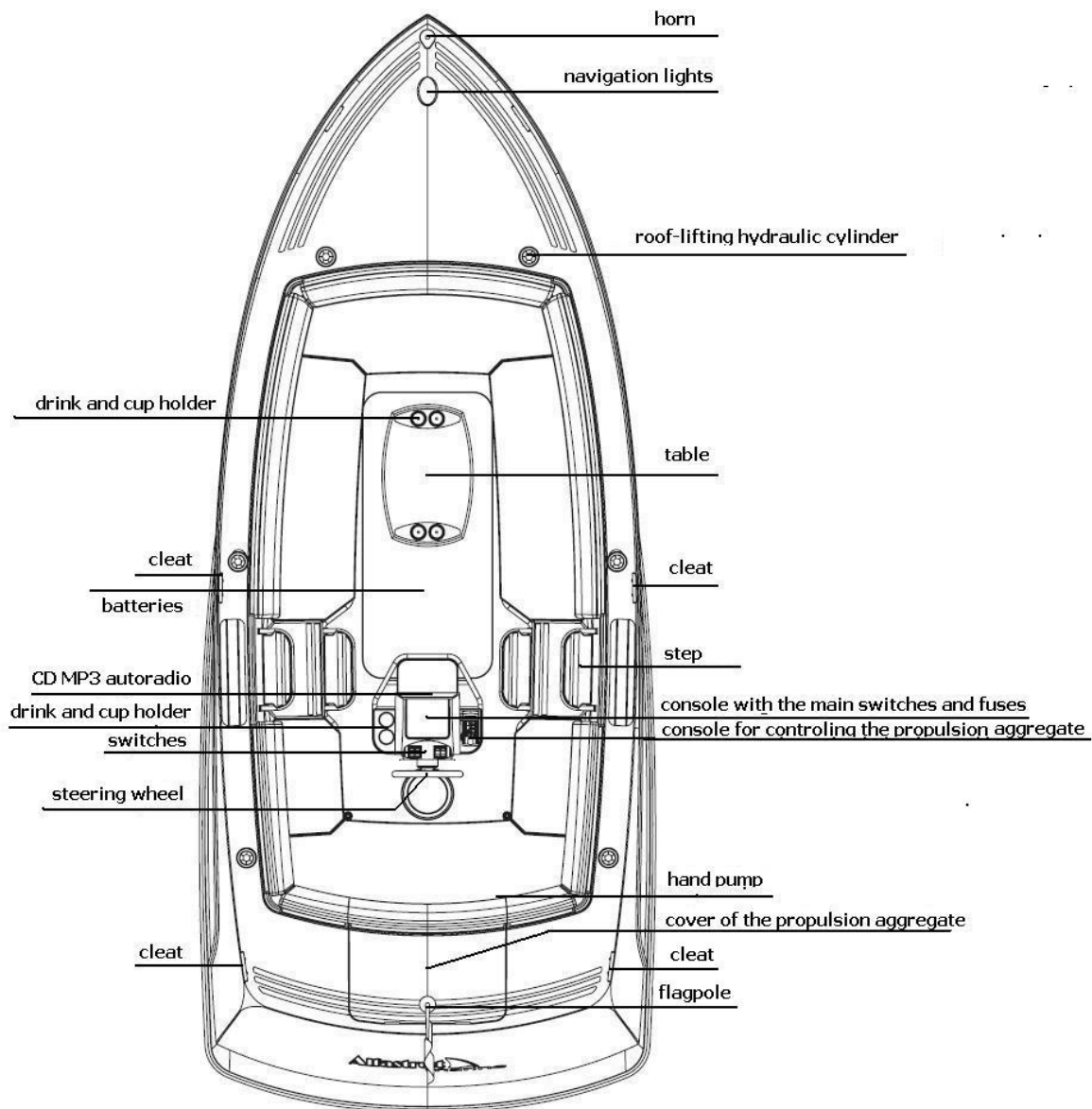

Picture 6: Ground plan with parts of the vessel

4.2 Speed and autonomy

- Max speed of the vessel : 8 knots
- Cruising speed of the vessel: 5 knots
- Autonomy of navigation at max speed: 3.5 hours
- Autonomy of navigation at cruising speed: 10 hours x 5 knots = 50 nautical miles

The speed and autonomy data is informative and measured in ideal conditions. The actual value can differ from the envisaged ones due to environmental factors (weather

conditions, battery status, load on the vessel, the condition of the vessel below the waterline, algae growth and dirt on the hull), the water current ...

4.3 Carrying capacity

The vessel Energy18, is registered for 8 adults, in other words, its carrying capacity is 700 kg, which includes all persons on board, the motor and the luggage or load. It is very important to take this into account, as, in the event of overloading, the stability of the vessel would be considerably reduced, making the navigation dangerous.

4.4 Stability

Your vessel was built in accordance to all regulations and standards related to the stability and navigational characteristics of the vessel determined in the certificate. Each overloading of the vessel can put the stability and navigational characteristics at risk, which could result in the non-stability of the vessel and/or its sinking.

Additional guidelines:

- the stability of the vessel is reduced if the load is put over the edge of the vessel,
- the stability of the vessel is reduced with the breaking of water into the hull or by adding load to the hull. Make sure that water will not break into the vessel's hull.

4.5 Motor power

The types of motor offered by the manufacturer have been carefully chosen to maximize the navigational capacities of the vessel. Therefore, do not install more powerful or bigger motors than the ones we offer. By installing a larger motor than the offered one, you would put in danger the safety of the navigation and the navigational characteristics of the vessel.

Moreover, the choice of the propeller installed to the vessel Alfastreet Energy18 is also the result of various tests and calculations, in order to suite the navigational characteristics of the vessel and guarantee its optimal functioning for its purpose and characteristics. Consult the vessel manufacturer before changing the propeller. If you intend to change the propeller, take into account the maximum recommended revolution, as described in the user guide for the motor. The revolutions must never be higher than the recommended ones!

In order to achieve the given motor power, the propeller must:

- be without damages on its blades,
- have no obstructions when rotating (rope or fishnet caught in the blades, or any other deformation to the propeller's axis, etc.).

If you notice any of the indicated damages to the propeller, it needs to be immediately checked by an authorized service centre. It is also recommended to keep a spare propeller on board, in order to change it immediately in case of damages.

4.6 Hull identification number

The hull identification number is located on the right side of the stern. It is the most important identification information about the vessel and it needs to be inserted in all documents, as well as in the order of the vessel. Absence of this information can lead to delays and inconveniences. Other important data include the motor's serial number and the serial numbers of other motor components. Consult the motor's user guide to know the locations of the said serial numbers.

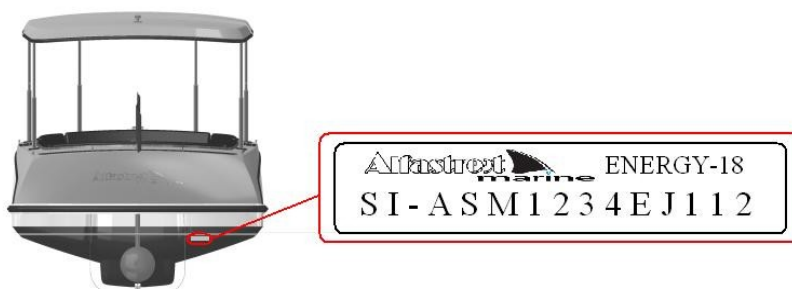

Picture 7: The vessel's identification number

The information on the indicated manufacturer's plate are just as important. The plate is located under the conductor's seat and features information on:

- the vessel's model,
- the vessel's category,
- the maximum number of passengers on board,
- the vessel's carrying capacity,
- the motor's maximum power.

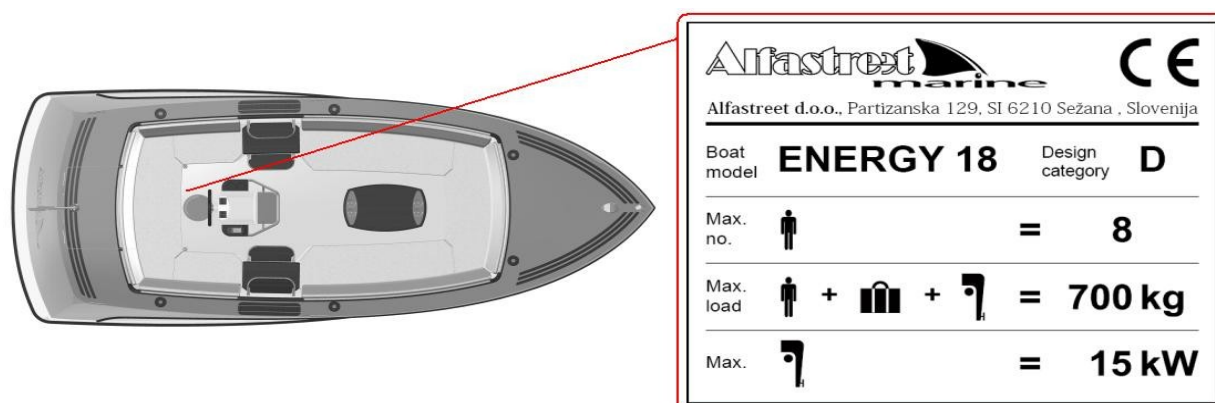

Picture 8: Manufacturer's plate

4.7 Manufacturer's certificates

Alfastreet Marine respects all the provisions of the CE regulation during the construction process of its vessels. As these vessels are sold all over the world, they respect all the standards based on the customer's country.

The most common standards are:

- ISO, which in Europe includes the CE regulation,
- NMMA certification in the USA.

4.8 International requirements

The vessel Energy18 was planned and built in accordance with various regulations and standards of the institutions indicated below and which were valid at the time of the vessel's construction.

- Ministere De La Mer – France
- Registro Italiano Navale – Italy
- Det Norske Veritas – Norway
- Securite des Nauires – Canada
- J.C.I. (Japan Craft Inspection) – Japan
- N.K.K. (Nippon Kaiji Kyokai) – Japan
- B.S.I. (British Standards Institute) – England
- Ministerio Obras Publicas YTransporters – Spain
- EC Recreational Craft Directive – European Community

4.9 Navigation and anchor lights

The vessel features a red and green navigation light in front on the prow (in one casing) and an anchor light on the roof. The navigation and anchor lights must be switched on whenever the visibility is reduced, the weather deteriorates or during the navigation at night.

When anchoring on a spot which could be on the navigational route of another vessel, switch on the anchor light located on the vessel's roof, which is visible 360° around the vessel.

5 ELECTRICAL INSTALLATION

The current-using equipment of the vessel works on a direct voltage, which, depending on the current-using equipment, can be 12V, 24V or 48V (volt). The source of the supply voltage is the lead-acid batteries with GEL electrolytes, installed in the hull. The batteries are 12V/ 210Ah. The number of batteries depends on the current-users and varies from 1 to 4. As with any other circuit, you must be careful not to cause any short circuits between the conductors on the vessel. You must also be careful during any interventions in the battery area. If a conductive object falls on the battery clamps and causes a short circuit between the poles of the battery, this causes a large current, sparkling and could result in a fire on board the vessel.

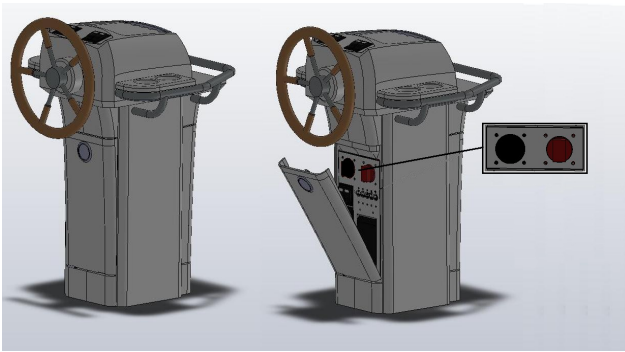

Picture 9: Main switches

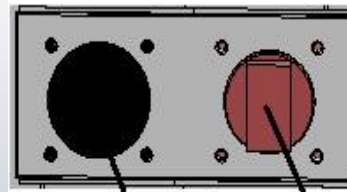

Main switch of the el. installation
Main ignition switch

Picture 10: Purpose of the main switches

5.1 Diagram of the vessel's electric circuits

This chapter features a presentation of the electrical circuits on the vessel.

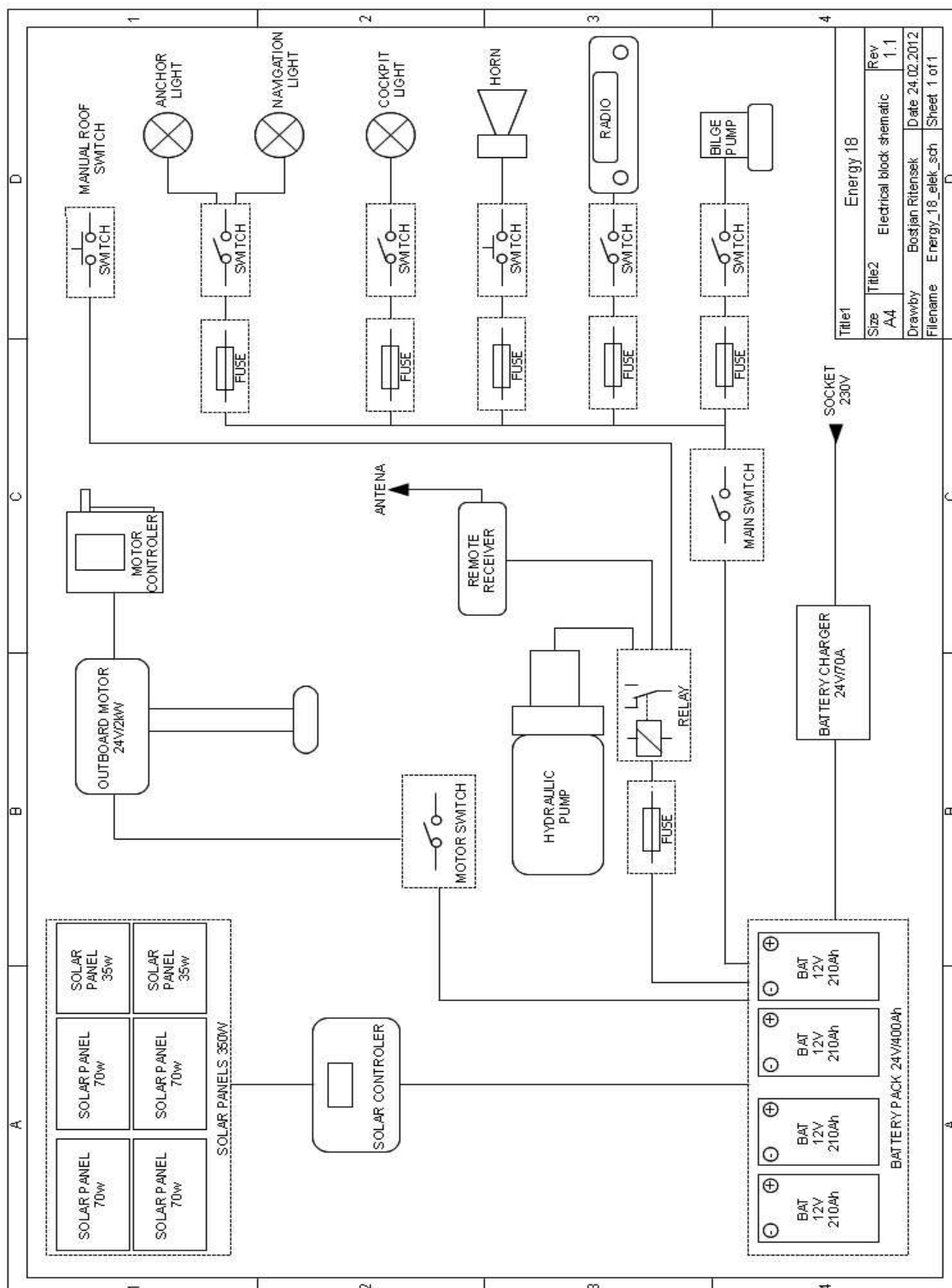

Picture 11: 5.1 Diagram of the vessel's electric circuits

5.2 Batteries

The vessel Energy 18 features four lead-acid GEL batteries, tested according to the EN 60254-1 standard with a closed construction of the cover, regulated with valves (VRLA) and a gel electrolyte. The advantages of such batteries are:

- no need for maintenance,
- clean and environment friendly,
- no leaks of the acid vapour,
- extremely low gas leak,
- safe use in closed spaces,
- minimal level of self-discharge (less than 3%/month),
- high number of charging cycles (600 cycles at 70% discharge),
- closed construction of the cover with valves and recombination,
- resistant to vibrations.

The GEL technology enables the recombination of gas. Thus, the hydrogen and the oxygen which are released during the battery charging and functioning, reunite and return into the battery in the form of water. During this procedure, 99% of gas returns into the battery. The recombination does not affect the reduced capacity of the battery or its lifespan.

Maintenance:

Thanks to the recombination of gas, the loss of water is very low. Therefore the battery does not need maintenance or refilling of distilled water or controls of the electrolyte level. This cannot be done without damaging the battery.

Safety discharge valve:

The battery features a safety discharge valve, which would open in the event of a pressure build-up in the battery caused by a too large quantity of gas. However, this cannot occur during normal charging and by taking into account the guidelines issued by the manufacturer of the battery and the charger.

Self-discharge:

The average level of self-discharge at the room temperature of 20°C is less than 3% a month. This means that a battery, which is out of use for approximately 16 months, maintains 50% of its capacity.

Disconnecting the batteries:

In the event of changing the batteries or if the batteries must be disconnected due to other reasons, this should be done in the following steps:

- first, disconnect all current-using objects on the vessel,
- remove both negative battery leads,
- remove both positive battery leads.

5.3 Battery charge with the system voltage of 220V

The procedure of charging the batteries with the energy coming from land requires special caution. As we know, using electricity is dangerous and by doing this near the water or wet surfaces, it becomes increasingly dangerous and requires a higher amount of caution than on land. Only a charger approved by the manufacturer should be used to charge the batteries. If the charger breaks down or stops working for other reasons, consult the manufacturer or supplier of the vessel before purchasing a new one. The use of a wrong charger can lead to the overloading of the batteries or the charger, which can result in a fire on board or other accidents.

During the charging of the batteries, pay special attention to the following:

- the vessel must be firmly tied to the pier or anchored,
- all electric current-users on board the vessel must be switched off (the main switches of the current-users and the motor are positioned on „OFF“),
- make sure that the feeder cable which connects the vessel to the electric current is not damaged,
- the feeder cable must not touch water,
- the feeder cable must not hinder the movement around the vessel (it should not be tightened across walking surfaces, thus posing a danger to pedestrians).

5.4 Battery charge with solar cells

The vessel Energy 18 can also feature solar cells. These are installed on the roof of the vessel and serve for charging the batteries. Of course, this does not mean that it is possible to navigate only with the help of the energy produced with the solar cells, as a full recharge of the batteries would require approximately 5 sunny days. A correct functioning and adequate charge of the batteries is provided by the regulator PR2020, which is located on the control console, next to the fuses.

Solar Charge Controller STECA 2020

The latest charging technologies, combined with a Steca- AtonIC state of charge determination which has been significantly improved once again, result in optimal battery maintenance and control of the module output of up to 900 Wp which can be connected to it. A large display informs the user about all operating modes with the aid of symbols. The state of charge is represented visually in the form of a tank display. Data such as voltage, current and state of charge can also be displayed digitally as figures on the display. In addition, the controller has an energy meter which can be reset by the user.



Picture 12: Solar Charge controller

Electronic protection functions:

- Overcharge protection
- Deep discharge protection
- Reverse polarity protection of load, module and battery
- Automatic electronic fuse
- Short circuit protection of load and module
- Overvoltage protection at module input
- Open circuit protection without battery
- Reverse current protection at night
- Overtemperature and overload protection
- Battery overvoltage shutdown

Technical data:

- System voltage: 12V
- Open circuit voltage solar module: <47V
- Solar modul current:20A
- Load current:20A
- End of charge voltage: fluid 13.9V; GEL 14.1V
- Ambient temperature: -10°C ... +50°C

Display windows:

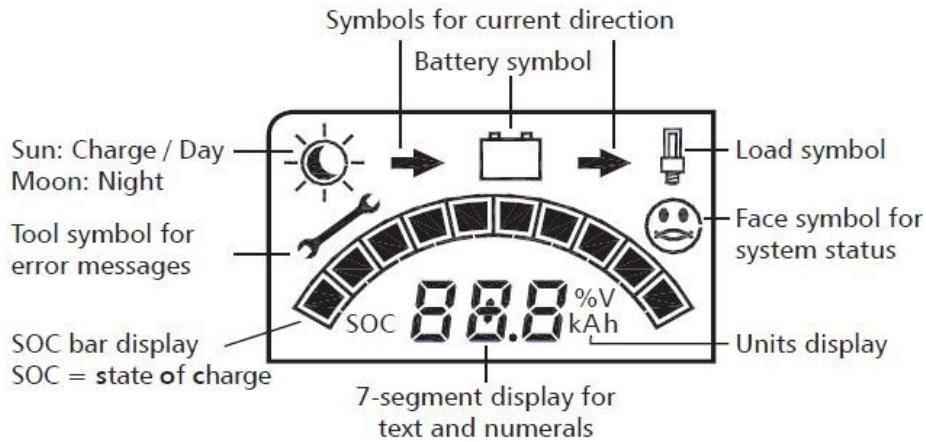

Picture 13: Solar Charge controller LCD display

The display windows contain different types of system information. The left button can be used to switch between the different display windows. After the last window, the first window is displayed once more. The following figures show examples of system information in the *SOC control* operating mode. The following differences exist in the *Voltage control* and *Voltage control with bar display* operating modes:

- **Voltage control:** The windows do not contain any SOC bar display. The SOC window shows the battery voltage instead of the SOC.
- **Voltage control with bar display:** The bar display shows the battery voltage in all windows. The SOC window shows a numerical value for the battery voltage instead of the SOC.

Notes:

Note that the accuracy of the bar display cannot be compared with the accuracy of a measuring device!

SOC window

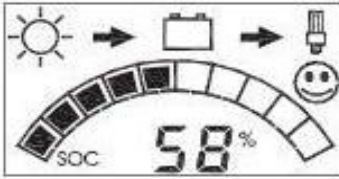

Displays the charge state, day / night status and load on / off status.

In the *Voltage control* operating mode, the battery voltage is displayed instead of the SOC value.

In the *Voltage control with bar display* operating mode, the battery voltage is displayed both alphanumerically and as a bar display.

Voltage window



Displays the battery voltage measured by the controller.

Module current



Displays the solar module output current.

Charging current

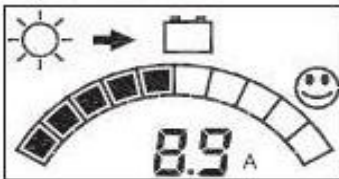

Displays the charging current into the battery.

Load current

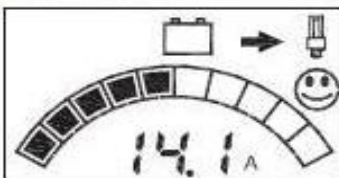

Displays the current being consumed from the load output.

Ah – Battery charge meter

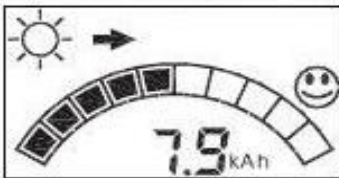

Displays the total Ah charged into the battery since initial installation or the last reset of the meter. Pressing and holding both buttons for 3 seconds resets the meter to 0. The value is retained when the battery is disconnected. After reaching a value of 99.9 kWh, the meter jumps back to 0 Ah.

Ah – Battery discharge meter



Displays the total Ah discharged via the load output since initial installation or the last reset of the meter. Pressing and holding both buttons for 3 seconds resets the meter to 0. The value is retained when the battery is disconnected. After reaching a value of 99.9 kWh, the meter jumps back to 0 Ah.

Deep discharge protection advance warning

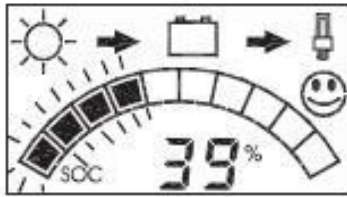

The following symbols flash in the various operating modes to provide advance warning of deep discharge.

- SOC bar (*SOC with bar display*)
 - Voltage value (*Voltage control*)
 - Voltage value and voltage bar display (*Voltage control with bar display*)
- The face symbol still looks happy.

Load disconnection



The following symbols flash when the deep discharge protection is active:

- Bar display (not in *Voltage control* mode)
- Battery symbol
- Right arrow
- Load symbol
- Alphanumeric value

The face symbol remains sad until the switch-on threshold is reached.

Notes:

For detailed informations please refer to Solar Charge Controller STECA 2020 user guide.

5.5 Battery maintenance

As mentioned in the previous chapter, the batteries on your vessel do not require special maintenance.

However, it is important that the batteries are:

- clean and dry,
- the clamps must be covered with silicone grease to prevent the oxidation of the lead contacts,
- if the vessel is not used for a longer period of time, especially during winter, remove the batteries from the vessel and keep them in a warmer and dry place (garage, boathouse, etc.),
- stick to the correct procedure of charging the batteries.

5.6 Fuses

Every circuit on the vessel is protected with automatic fuses. They are located on the control panel under the vessel's steering, under the seat in the prow and on the battery closest to the steering console. The fuses have different values, depending on the current on the user which they are protecting. If the fuse disconnects due to an increased current on the user, it is not necessary to change the fuse, but only to switch it on. Before switching it on again it is necessary to repair the error on the circuit. If, however, the fuse

does need to be changed, it is necessary to take into account its value and substitute it with a fuse of the same value.

5.6.1 Fuse for moving the roof

The fuse is located under the seat in the vessel's prow (as indicated in the picture below). You can reach it by removing the seat's pillow in the prow and the drawer under the pillow. The fuse is on the right and is automatic, which means that when it disconnects, there is no need to replace it, just put it back into its working position. Before doing this, you must find out the reason for the overload and the disconnection. Only then the fuse can be put into the working position (as shown in the picture – position „ON“).

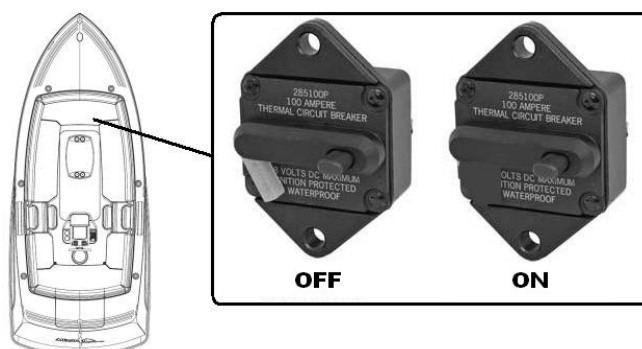

Picture 14: Location of the fuse for moving the roof

5.6.2 Fuses of other current-using components

The fuses of other current-using equipment are located on the control panel of the control console under the steering wheel. They are reachable by opening the cover. These fuses are also automatic, therefore they do not need to be replaced when disconnected, it is enough to put them back into the working position. Before doing this, it is necessary to find out the reason for the overload and the disconnection of the fuse. Only then the fuse can be placed back into the working position.

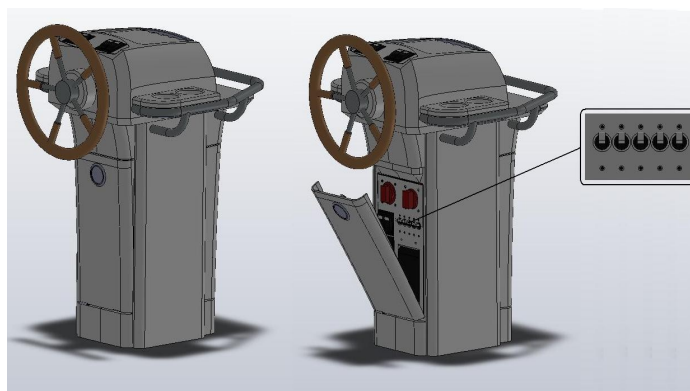

Picture 16: Fuses location

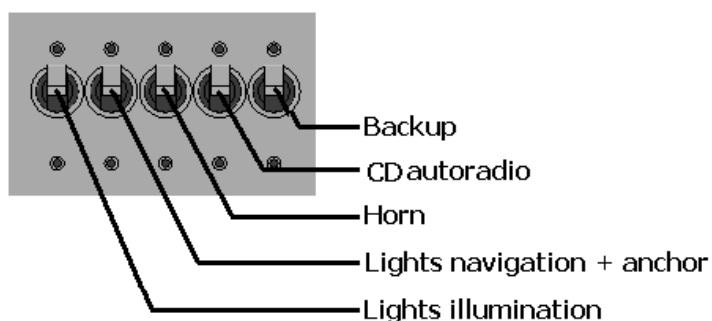

Picture 15: Purpose of the fuses

5.7 Switches for the current-using components

The control console features all the switches to switch on the electric current-using components and the fuses. All the switches are watertight, so you can be carefree about the water breaking into the control console. All the current-using components are connected through the fuses, which, in case of an error in the circuit or flooding of the electricity network, disconnect the electrical current, thus preventing an accident or even a fire. If the fuses need to be changed, be careful to replace them with a fuse of the same current value.

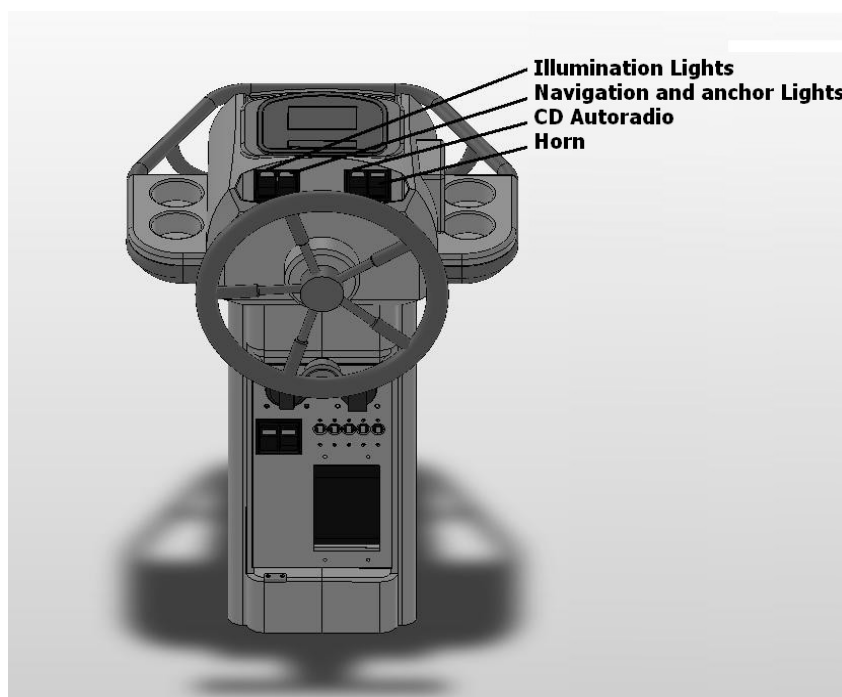

Picture 17: Switches

6 MOTOR

6.1 Electrical motor

As for every other component and equipment installed into your vessel, it is also necessary to read the user guide for the motor before its first ignition. The most important guidelines

and instructions are collected in this chapter, whereas more detailed instructions for use are enclosed to this manual.

The vessel Energy18 features the electrical motor Torqeedo 2.0R or 4.0R.

6.1.1 Protection of the electric motor

As every other current-using component on the vessel, the electric motor also has its own main switch and fuses. It is very important to put the main ignition switch into the position „OFF“, when leaving the vessel. By doing so, we prevent any fire or other inconveniences caused by an error to the electricity system during our absence. The current value of the motor's fuse was carefully chosen, just as with all other current-using components. Therefore, it is forbidden to install a fuse with a higher current value or even to short circuit a damaged fuse! There is always a good reason for an automatic fuse to disconnect or burn out. That is why a replacement with a higher current value would create a great potential for causing a fire and putting the persons on board in danger.

6.1.2 Torqeedo Cruise 2.0R technical data

Model	Cruise 2.0R	Cruise 4.0R
Moč (W)	2000	4000
Napajalna napetost (V)	24 – 25,9	48 – 51,8
Pogonska moč	1120	2240
Moč v primerjavi z bencinskim motorjem (KS)	5	8
Napetost akumulatorjev pri kateri se motor avtomatsko izključi (V)	Litij-Ion akumulatorji 21V Svinčevi akumulatorji 18V	Litij-Ion akumulatorji 42V Svinčevi akumulatorji 36V
Največji izkoristek moči (v%)	56	56
Teža (kg)	16	17
Dolžina gredi (mm)		
Dimenzije vijaka (mm)	304,8 x 254	304,8 x 254
Največje število vrtljajev vijaka	1300	1300

6.1.3 Plan of operating elements

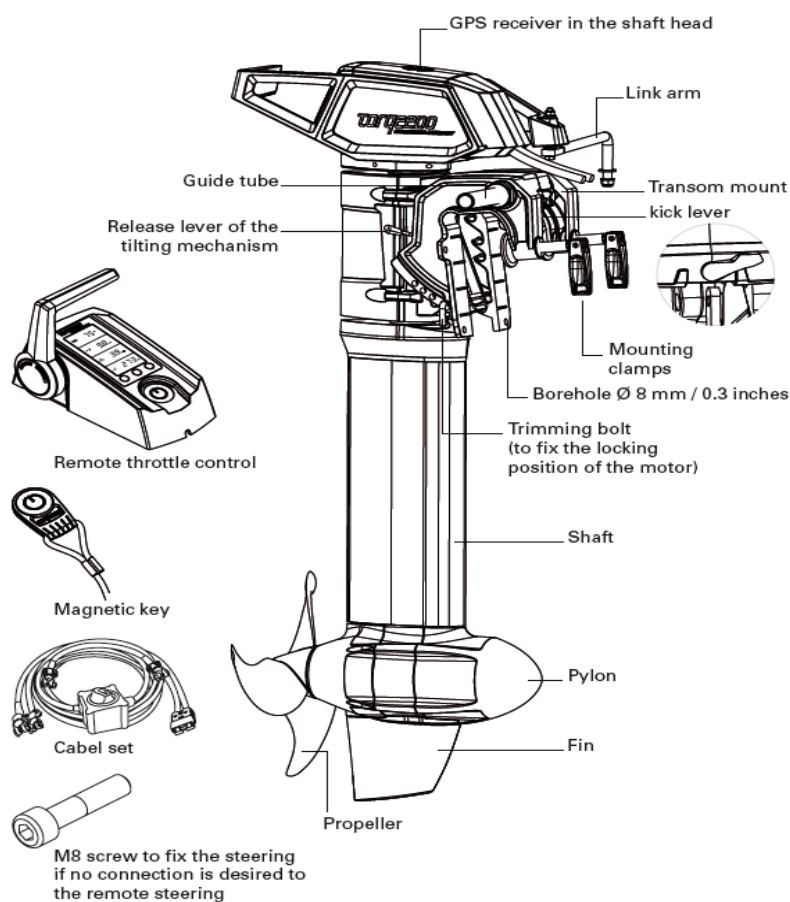

Picture 18: Operating parts

6.1.4 Remote throttle with integrated display and magnetic key

Control the drive power - propeller speed and direction - by adjusting the remote throttle. Forward movement of the remote throttle means the boat moves forward, backward movement of the remote throttle means the boat moves in reverse. Please note that the output is restricted when reversing. The central position is the stop position.

The remote throttle control is equipped with a magnetic key with an on/off function. The motor only works if you place the magnetic key supplied on the proper recess on the remote throttle control (see drawing). If the magnetic key is removed the motor stops. You can only start the motor again if you first replace the magnetic key and then move the remote throttle to the central position (stop position).

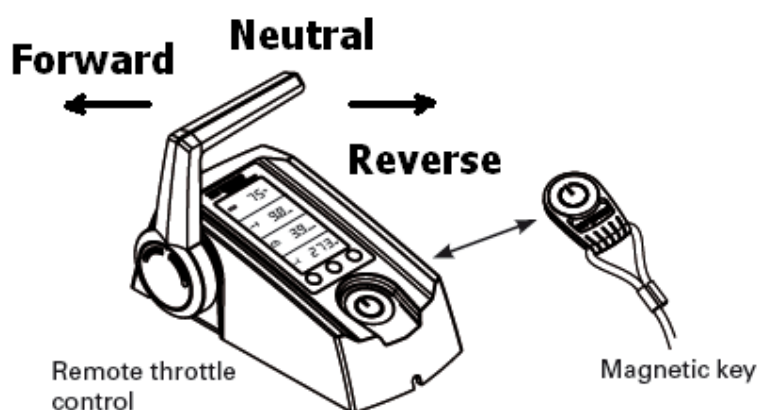



Picture 19: Remote control throttle with magnetic key

The remote throttle control is equipped with an integrated display and three buttons. If you press the "on/off" button for 1 second while the magnetic pin is placed on the throttle you switch on the motor. Pressing the button again for 3 seconds switches the motor off again. You can switch the motor off in any operating mode. If there is no activity for 1 hour the motor switches off automatically. Press it again to switch it back on.

6.1.5 Setting up the battery charge indicator

1. To enter the setup menu press the "setup" button for 3 seconds.
2. Select the units in which the remaining range is displayed. Push the button in the center of the display to select between kilometers, miles, nautical miles, and hours. You confirm your selection by pressing "setup" again.
3. Now, enter the speed indicator setting. You can choose between kilometers per hour, miles per hour, and knots. Again you select the units with central button. Confirm your selection by pressing "setup" again.
4. Then, choose whether the battery status shall be displayed in percent or in volts.
5. The next step is to supply the on-board computer with information about the batteries. Start with entering whether the motor is connected with lithium batteries from the Torqeedo power series or with lead-gel or AGM batteries. Select "Li" for lithium or "Pb" for lead-gel or AGM batteries. Confirm your selection by pressing "setup" again.
6. Enter the size of the battery bank with which the motor is connected. For this enter ampere-hours (Ah) for the battery bank. Please use the throttle lever to select the correct number of ampere-hours. Pushing the "setup" button will confirm your selection and exit the setup-menu. Please be aware that for example a battery bank consisting of two 12 Volt batteries with a capacity of 200 Ah each connected in series will give you a 24 Volt battery bank with a capacity of 200 Ah, not 400 Ah. For a more detailed explanation please read Section 8 in this operating manual (basic information on battery supply).

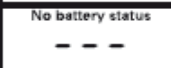



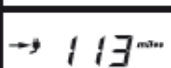
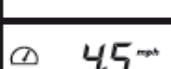
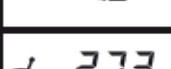

Display example in normal operation when setup has not been completed:

	Battery voltage (flashing below 11.2 V per lead battery)
	Can not be shown
	Speed
	Input power consumption

Display example in normal operation:

	Battery charge (flashing below 50 % of capacity)
	Remaining range at current speed
	Speed
	Input power consumption

Other indications:

	Drive slowly: Is displayed if the battery capacity is < 50 % or if the voltage falls below a value that could damage the battery.
	No battery status: Is displayed if setup was not completed.
	 : The GPS module integrated into the shaft head searches for satellite signals to determine the position and speed. If no GPS signal is received within 5 minutes, the remaining duration in the second field from the top changes from distance to time information. In addition, a clock icon is displayed. If the remaining duration is more than 10 hours it is indicated in whole hours. If it is less it is shown in hours and minutes.
	
	

 **Stop**: This icon is displayed if the remote throttle must be placed in the central position (stop position). This is necessary for safety reasons before starting off.

: Is displayed if the motor has overheated. The motor controls the power independently.

Error: If an error occurs, the error icon and a two-digit code are displayed in the bottom field. The code shows the component causing the error and the error itself. You will find details about the error codes in the following table.

The following table contains a list of possible error codes:

Fault codes		
Display	Cause	What to do
E02	Stator over-temperature (engine overheating)	Motor can be used again after a short waiting period of 10 minutes. Contact Torqeedo Service.
E05	Motor/propeller blocked	Loosen blockage and turn propeller one revolution by hand.
E06	Voltage in the motor too low	Low battery charging status. Motor can be used again slowly from the stop position.
E07	Motor overcurrent	Continue at low output. Contact Torqeedo Service.
E08	Circuit board overheating	Motor can be used again after a short waiting period of 10 minutes. Contact Torqeedo Service.
E21	Remote throttle calibration defective	<ul style="list-style-type: none"> • Re-calibrate: • Press "cal" button for 10 seconds. • The display shows "cal up": Press remote throttle control forward to full gas then press the "cal" button. • The display shows "cal stp": Return remote throttle control to central position then press the "cal" button. • The display shows "cal dn": Press remote throttle control revers to full gas then press the "cal" button.
E22	Magnetic sensor defective	Re-calibrate (refer to E21).
E23	Value range false	Re-calibrate (refer to E21).
E30	Motor communication error	Check the motor cable's plug-in connection. Check the motor cable for damage.
E32	Remote throttle communication error	Check the remote throttle cable's plug-in connection. Check the cable.
E33	General communication error	Check the plug-in connections and cables.

Fault codes		
Display	Cause	What to do
E36	Input voltage too high	The input voltage is higher than the 35 V (Cruise 2.0 R) or 65 V (Cruise 4.0 R). Check the battery connection as per Section 8.
E45	Battery overcurrent	The electronics measure unusually high power consumption. Motor can continue to be used slowly. Contact Torqeedo Service.
E46	Overtemperature on the electronics	Can occur with extremely high external temperatures, high output and low battery charging status. The motor can continue to be used after the temperature has stabilized.
Other error codes	Defects	Contact Torqeedo Service and notify them of the error code.

6.1.6 Trouble shooting

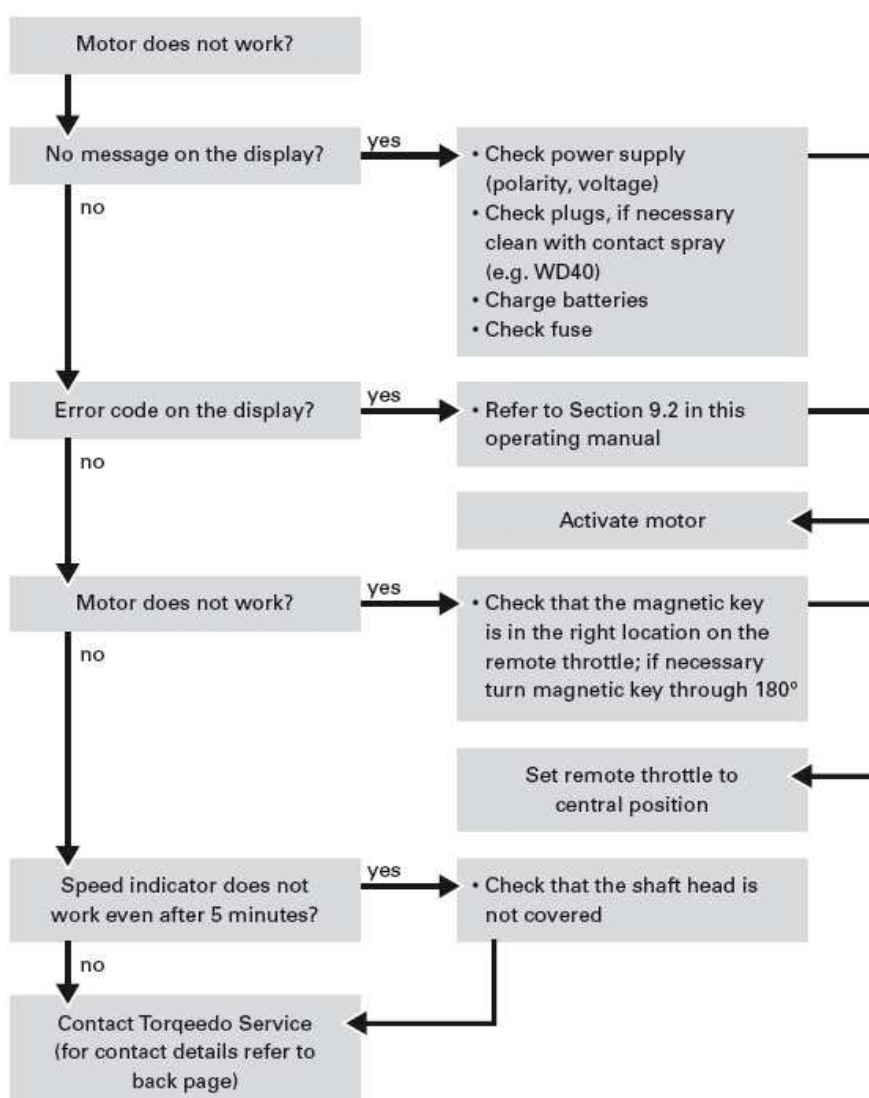

6.1.7 Pylon

The motor and **electronic control system** are located in the pylon. They generate the propulsion. In addition, several protective functions are integrated:

1. **Temperature protection:** If the motor overheats, the motor control system reduces the output of the drive until a temperature equilibrium is established between generated and disposed heat. Above a critical temperature the motor stops and the display shows error code E02 or E08.
2. **Under-voltage protection:** If the voltage falls below 16 V (Cruise 2.0 R) / 36 V (Cruise 4.0 R), the electronic controller switches the drive off to prevent over-discharging the batteries. The display shows error code E06.
3. **Blocking protection:** If the propeller is blocked or stuck, the motor would normally take in too much power. In this case, the motor is switched off within a few hundredths of a second to protect the electronics, motor winding and propeller. After removing the blockage you can switch the motor on again. If there is a blockage the display shows error code E05.
4. **Cable break protection:** If the connection cable is damaged, i.e. if the connection to the remote throttle is broken the motor will not start, respectively it will stop. An error code is shown on the display.
5. **Throttle control:** The speed at which the propeller adjusts to a changed tiller position is limited in order to protect mechanical drive parts and to avoid short-term peak current.

6.1.8 Changing the propeller

1. Set the main battery switch to the "off" position.
2. Loosen and unscrew the self-locking hexagon nut on the propeller.
3. Pull the propeller with the external disk from the motor shaft.
4. Pull the cylinder pin from the motor shaft and remove the internal disk from the motor shaft.
5. Set the main battery switch to the "on" position. Allow the motor to run slowly and check whether the shaft is turning unevenly at the shaft sealant ring. Contact Torqeedo Service if the shaft is damaged or uneven.
6. Set the main battery switch to the "off" position. Insert the new cylinder pin centrally to the motor shaft and insert the internal disk onto the motor shaft.
7. Place the propeller onto the motor shaft and turn the propeller until the cylinder pin fits into the groove of the propeller.
8. Place the external disk over the motor shaft and screw the self-locking hexagon nut onto the shaft.

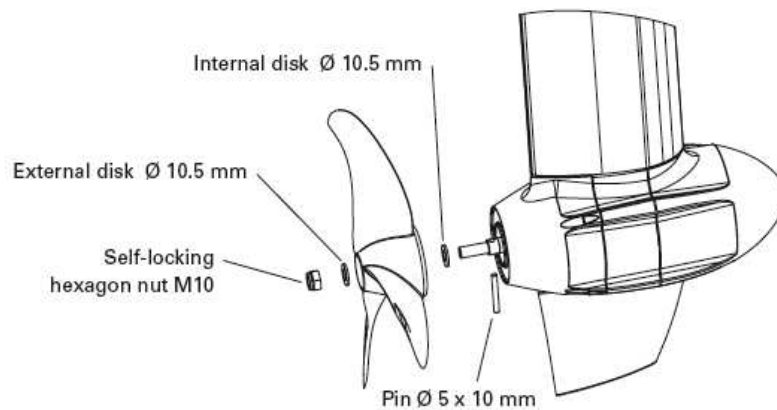

Picture 20: Parts of propeller

Notes:

For detailed informations please refer to Torqeedo Torqeedo Cruise 2.0R user guide.

7 HYDRAULICS

7.1 Construction

The hydraulic system for lifting the roof is composed of four hydraulic cylinders and an oil pump, which are connected with high-pressure pipes. The levelled lifting and lowering of the roof is ensured by the balancing mechanism with the wire ropes.

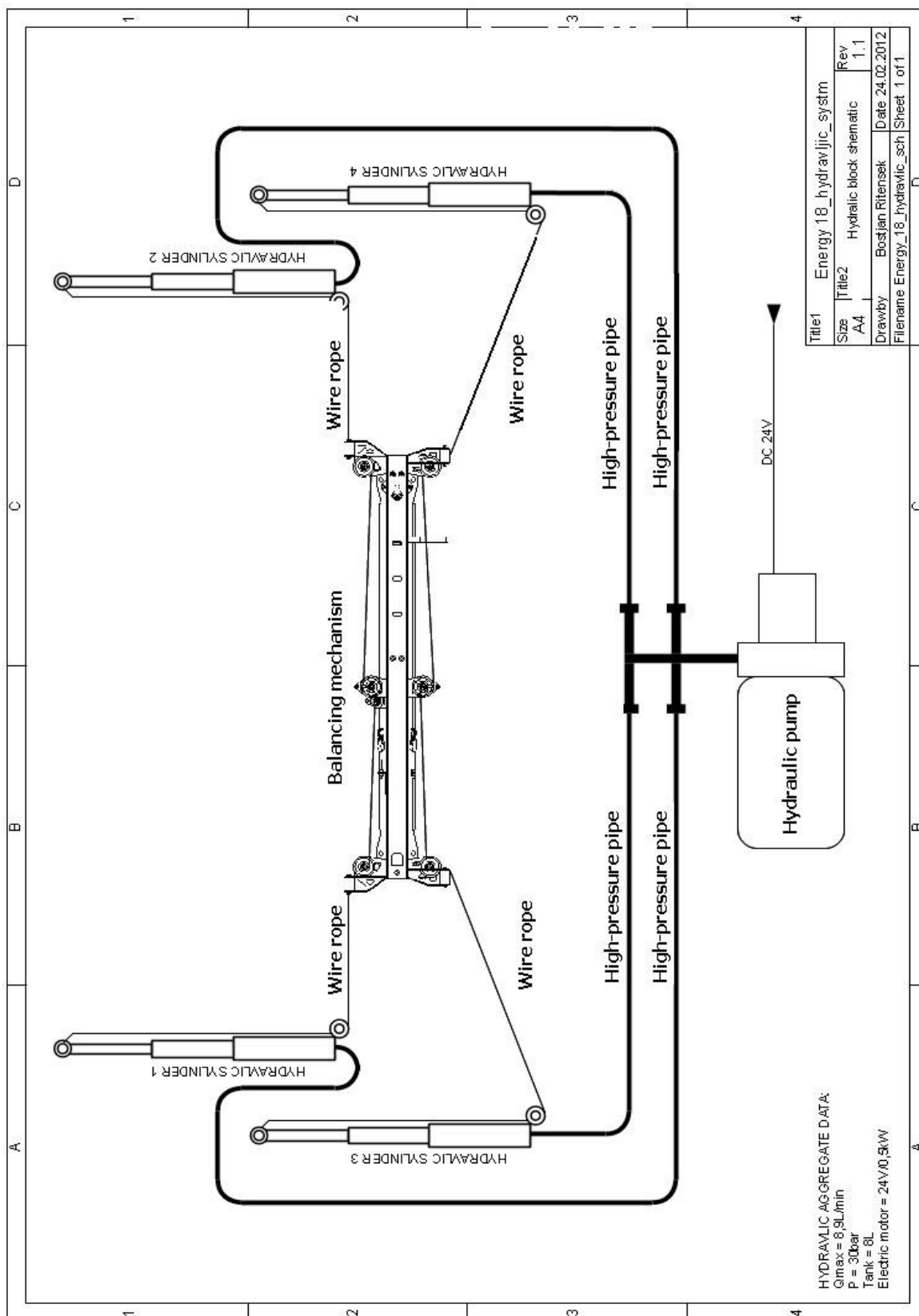

7.2 Hydraulic aggregate

The hydraulic aggregate is intended for the propulsion of the hydraulic cylinders for lifting the roof of the vessel Energy 18. The hydraulic aggregate is located in the front part of the prow and is reachable through the prow's service opening.

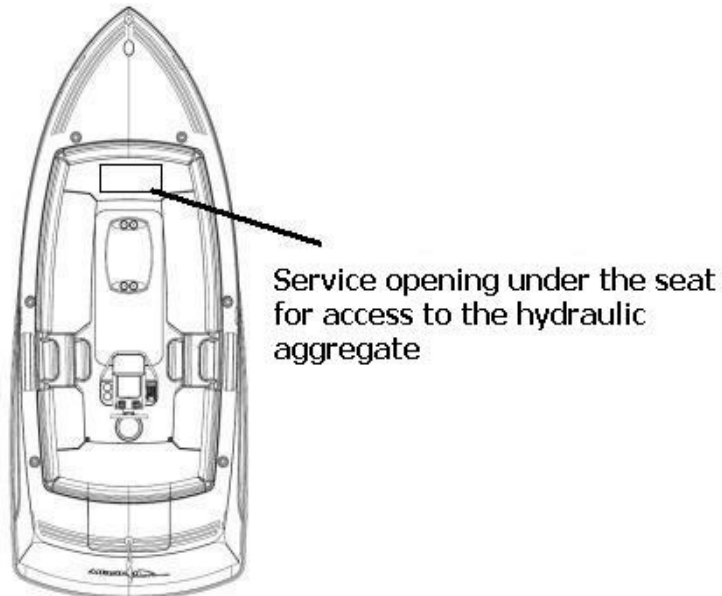

Picture 22: Service opening of the hydraulics

The hydraulic aggregate is composed of:

- the hydraulic pump,
- the electric motor for the propulsion of the hydraulic pump,
- the reservoir for the hydraulic oil.

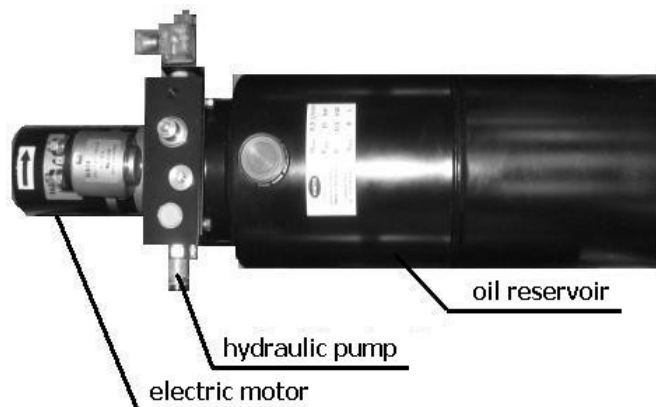

Picture 23: Hydraulic aggregate

Technical data of the aggregate:

Hydraulic pump: $Q_{max} = 8,9L/min$, $P_{max} = 30bar$

Reservoir: $V = 8L$

Electric motor: $24V/0,5kW$

Maintenance of the hydraulic aggregate.

- Hydraulic oil, oil level
Only the hydraulic oil with the viscosity of VG46 can be used. Using other oils or mixing with oils with various viscosities is forbidden! The reservoir of the hydraulic oil has the capacity of 8L. the oil level needs to be regularly checked and refilled when necessary. Oil level and opening on (picture).
- Electric motor for the propulsion of the hydraulic pump
The electric DC 24V motor is charged directly through the battery block and it is connected through the power fuse 80A, located on the right side of the hydraulic aggregate (picture). If the fuse disconnects, place it back in its position by pressing the on it.

7.3 Hydraulic telescopic cylinders

There are four active hydraulic cylinders, whose purpose is to lift the roof of the vessel Energy 18, that is two in front on the prow and two at the back on the stern. The central hydraulic cylinders are passive and serve as the lead (picture). The hydraulic cylinders do not require special maintenance, except for a possible de-aeration if the air occurs in the entire system.

The de-aeration procedure goes as follows:

- Lift the roof to its maximum height (see the chapter „Lifting and lowering the roof“, on page 34).
- Loosen the screw at the end of the piston rod right under the attachment of the piston rod to the roof. Loosen it enough to allow the air to escape out of it.
- When oil starts coming out instead of air, retighten the screw.
- Repeat the procedure on all four active hydraulic cylinders.
- Wipe the escaped oil with a clean cloth.

7.4 Return mechanism

The return mechanism enables a balanced movement of the roof. It is located under the steering console and can be reached through the opening of the batteries. **WARNING!** Danger of large forces of the gas spring's pressure!

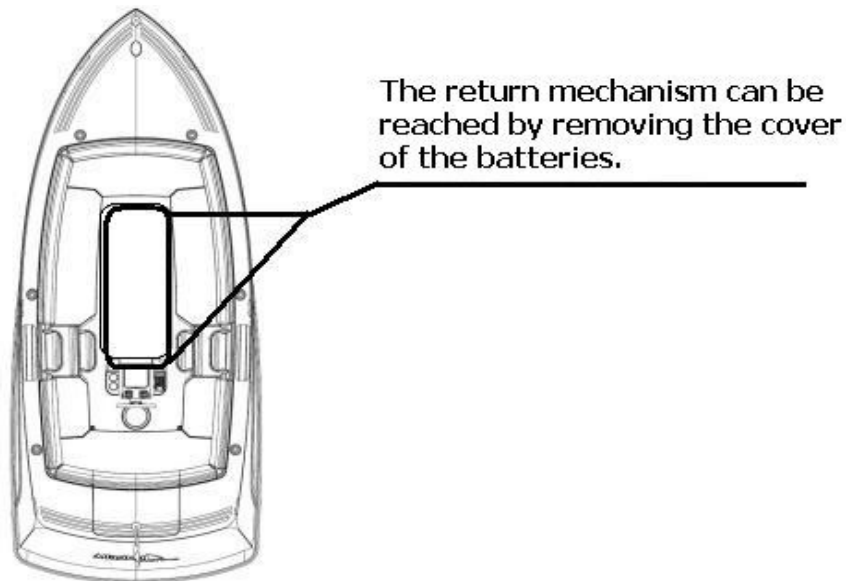

Picture 24: Access to the return mechanism



7.5 Steering mechanism

The vessel's steering mechanism is realized so that the steering wheel is connected through the motor to the wire rope, which, according to the conduction of the wheel, turns the motor left-right, thus conducting the vessel left or right.

The functioning of the control mechanism must be checked at least twice a year.

8 BEFORE THE NAVIGATION

8.1 Transport and lifting of the vessel

The vessel Energy18 can be transported on a trailer for the transport of vessels, pulled by a car. The vessel's towing dimensions do not require a larger vehicle or lorry. However, consult the vessel's manufacturer or representative before purchasing a trailer.

8.1.1 Lifting the vessel

Lowering the vessel into the water with a lift requires caution. It is very important to attach the lifting strap to the right spot. An incorrect attachment of the lifting straps could lead to the slipping of the vessel to the ground and its ruining. The straps must not be attached to the cleats. Their sole purpose is to tie the vessel to the pier and the positioning of the fenders. The spots where the lifting straps can be attached are indicated with a warning sticker. The lifting straps should be positioned as in the picture below.

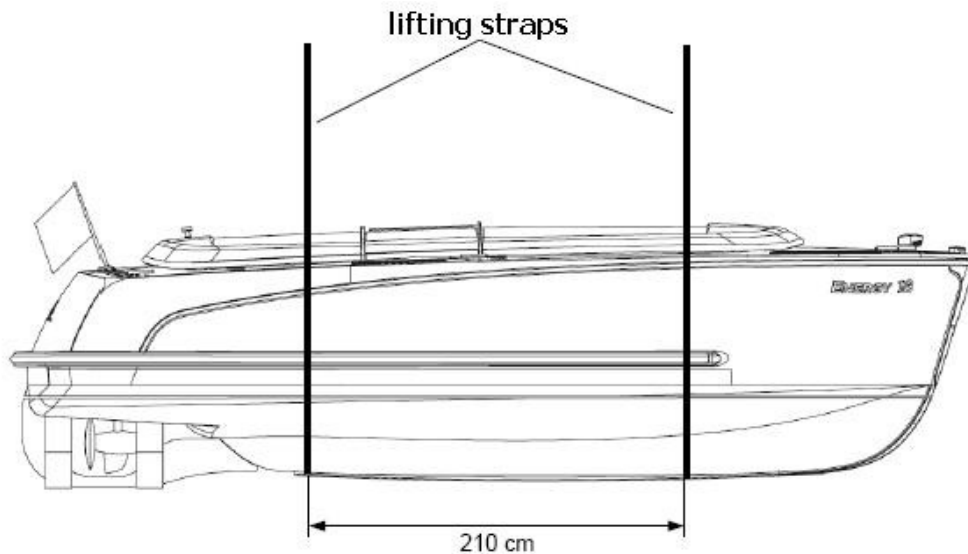

Picture 25: Lifting the vessel

8.1.2 Towing the vessel

If the vessel must be towed by another vessel due to a breakdown or if you run out of petrol, empty the batteries or for any other reason, carefully choose where to attach the vessel. Attaching it to the cleats is forbidden! The towing rope can be tied through the opening on the prow.

8.2 Lifting and lowering the roof

If your vessel features a sliding roof, its movement is enabled by the hydraulic mechanism. The movement of the roof can be switched on by pressing the button on the remote control or by pressing the button on the control console. When the roof is in its top position, the passengers can embark the boat more easily by additionally opening a part of the roof.

While lifting and lowering the roof, make sure that no one is standing in the area of the movement of the roof!



Picture 26: Remote control for the lifting and lowering of the roof

Lifting the roof:

- press the button to switch on the remote control (the blue control light is flashing),
- press the button on the left (indicated above with an upward triangle) and keep pressing until the roof is lifted to the upper point. If you stop pressing the button while the roof is lifting, its movement also immediately stops.

Lowering the roof:

- press the button to switch on the remote control (the blue control light is flashing)
- press the button on the right (indicated above with a downward triangle) and

keep pressing until the roof is completely lowered. If you stop pressing the button while the roof is lifting, its movement also immediately stops.

Both procedures can be done by pressing the button on the control console.

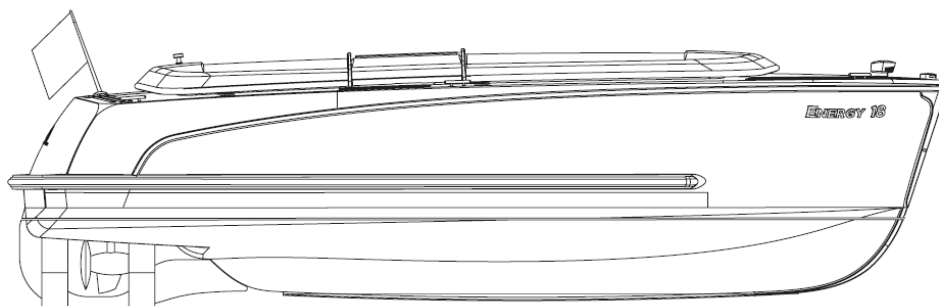

Picture 27: The vessel Energy18 with the lowered roof

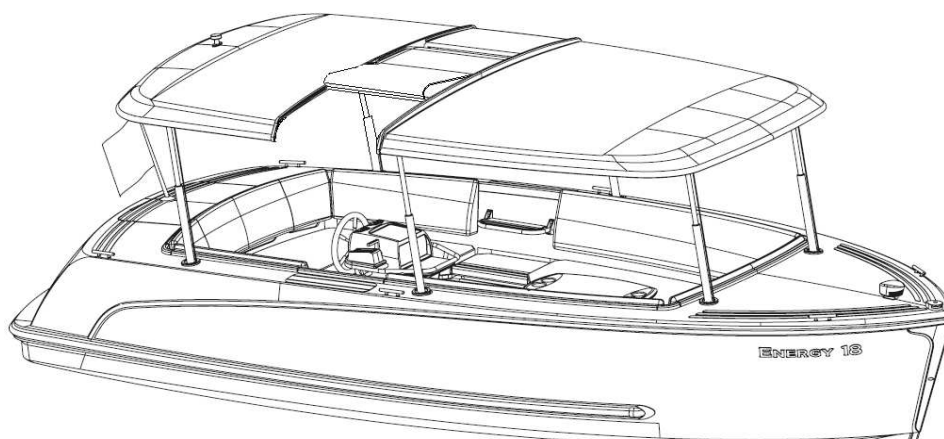

Picture 28: the vessel Energy18 with the lifted roof and the opened cover for an easier embarking

8.3 Embarking the vessel

While embarking the vessel, ensure the following:

- do not overload the vessel,
- one person can embark the vessel at the same time,
- help children, the elderly and anyone, who might need assistance while embarking the vessel,
- while loading objects from land onto the vessel, be very careful as you might lose your balance and fall into the water injuring yourself.
- Arrange the objects on board the vessel as evenly as possible not to endanger the stability of the vessel.

The object on the vessel should be at reach to the passengers and carefully stored in the intended storing surfaces. This is especially important when you navigate in turbulent waters or bad weather.

8.4 Fuel quantity and navigational length

ALWAYS check that you have enough fuel for the planned route or if the batteries are enough charged, before your departure. Otherwise, you might not be able to return to the shore which could be dangerous.

8.5 Navigation plan

The planned navigational route should be kept by a relative, a friend or someone you trust. Keep in touch with this person and inform him of your position. In the event that you do not contact the person you trust in the determined time, he will assume that something went wrong and contact help or organize a rescue operation.

8.6 Nautical charts

The nautical charts are important as the view from the lake is often different from the view from land, therefore the conductor can easily lose orientation. The nautical charts help him with the orientation and indicate the type and location of limits/obstacles on the lake.

8.7 Weather forecast

Check the weather forecast before departure, as the weather is unpredictable and can change quickly. To increase your safety and to prevent any unpleasant surprises, check for any coming storms, the current blowing wind and the condition of the waves. Bad weather, too large waves and strong wind can be dangerous or even deadly.

8.8 Measures before departure

Every conductor must ensure the following before the departure:

- all passengers know the location of the life jackets and how to use them,
- children and non-swimmers are wearing the life jackets during the entire navigation,
- advise your passengers to put on the life jackets anyway, especially in bad weather,
- if the passengers are not wearing the life jackets, the conductor takes them out of the compartments, so that they are ready for use immediately,
- all rescue equipment and tools are reachable and ready for use during the entire navigation,
- the conductor knows how to react in emergencies.

9 DURING THE NAVIGATION

9.1 Position of the passengers during the navigation

During the navigation, all passengers including the conductor of the vessel must be seated. They should not sit on the roof, the motor's cover, the deck and other inappropriate places on the vessel, but in the areas designed for sitting. The sitting areas on the vessel are indicated in the picture below (indicated by „SEAT“). Sitting on other areas can be dangerous.

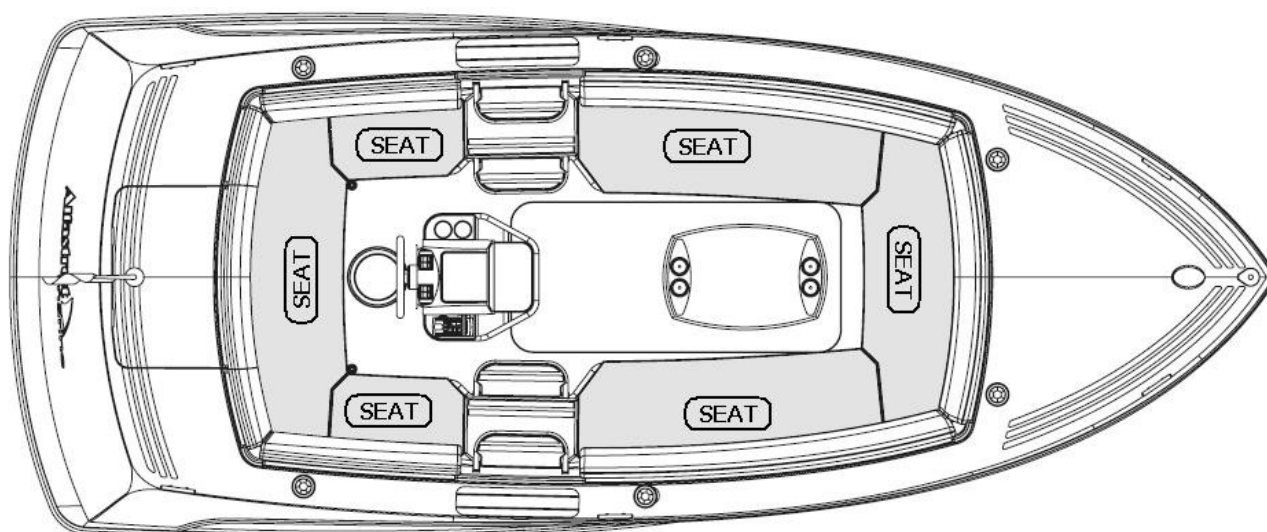

Picture 29: Areas for sitting during the navigation

The conductor is responsible for the passengers' supervision during the entire navigation. If necessary he needs to warn them about any inappropriate behaviour, adapt the speed of navigation or even stop the vessel, if he reckons that any of the passengers' behaviour is putting him or other passengers in danger.

9.2 Motor angle

The electric and the gas outboard motors on the vessel Energy 18 feature a manual positioning of the motor's angle (trim). The manufacturer's or distributors' installation is ideal, therefore it should not be modified. In the event of changing the angle, this should be done only for the increase the efficiency of the propulsion (the result is lower consumption and/or higher speed).

9.3 Safety switch for shutting down the motor

The vessels with the electric motor Torqeedo are especially safe, as they feature a safety mechanism which shuts down the motor if the conductor leaves the motor's control console. This can happen in the event of the conductor's sickness, passing out, falling over the deck due to turbulent water, strolling around the vessel under the influence of forbidden substances, or if he wanted to shut down the motor for safety reasons. This safety mechanism can prevent a serious accident. A vessel moving without control can present a serious danger to the passengers on board as well as the people in the water around the vessel. Of course, the correct functioning of the mechanism largely depends on the vessel's conductor. As mentioned before, the conductor must attach the string of the safety key to himself. If he does so, in the event of an accident, by leaving the control console, he will pull the safety key out of the key hole and cause the motor to shut down. After the safety shut down, position the handle for direction and speed into the neutral position and then insert the safety key into the console (as shown in the picture below).



Picture 31: Correct placement of the safety key

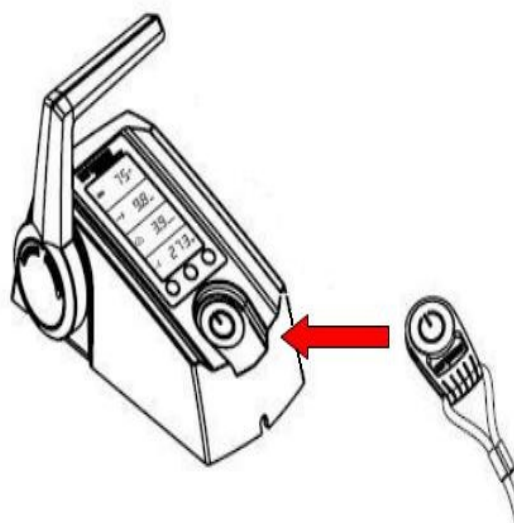

Picture 30: Correct placement of the direction handle and the safety key

9.4 Ignition

When all passengers are safely seated on board, you can begin the ignition process. This is done in the following steps:

- untie the vessel,
- put the main switch of the motor into the „ON“ position,
- check the battery charge on the control console of the motor,
- position the direction handle into the desired direction of navigation.

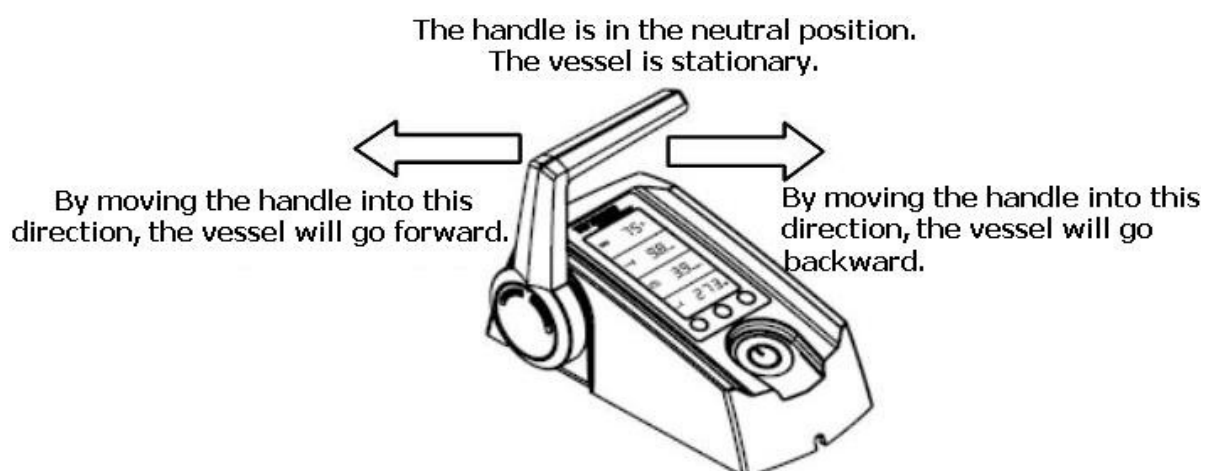

Picture 32: Position of the direction handle

9.5 Observing the surroundings during navigation

When on board the vessel, you should always be aware of your surroundings. Accidents can occur very quickly, therefore you must never leave the vessel uncontrolled, especially when the motor is running. When conducting the vessel, pay attention to what is happening in front of the vessel and be ready to shut down the motors immediately. If an unexpected event/accident occurs, shut down the motors IMMEDIATELY and call for help. Moreover, pay attention to the passengers during the navigation, as they are your responsibility. If any of the passengers fall into the water, shut down the motor immediately and throw the person in the water a rescue ring or any other floating object.

9.6 Passenger safety

During the navigation, the passengers must ALWAYS stay in their places. Any large movements can distract the conductor, who is no longer fully aware of the surroundings and the safety of everyone involved. In order to ensure bigger safety, the passengers should wear the life jackets. Do not forget that you are not only in charge of your safety, but also the safety of everyone around you.

9.7 Autonomy of the batteries

Regularly check the charge level of the batteries during the navigation. When the level is reduced, immediately head towards your destination or the nearest marina for a stop and recharge the batteries with the electricity from the distribution system.

9.8 Awareness and environment care

Disposal of waste

As for the land, the same regulations and moral ethics apply for the disposal of waste on water. Therefore, we kindly ask you to collect the waste which gathered during the navigation in the intended bags and to dispose of them after the completion of the navigation into the designated containers in the marina or wherever you tie the vessel. Throwing the waste over the deck would be very irresponsible and immoral. At the same time we would like to remind you to collect the waste separately.

Noise

Some areas have specific regulations about noise, which you need to respect. Nevertheless, it would be appropriate and polite not to cause too much noise with music, hooting or screaming. Your vessel is not soundless, therefore try to create an appropriate level of noise.

10 AFTER THE NAVIGATION

As for the time before and during the navigation, the time after the navigation requires the application of some guidelines.

10.1 Arrival notice

Inform the family members, to whom you trusted the information about your navigation that you have safely reached your destination. Failure to do so could result in an unnecessary call for help or rescue action as they would think that something happened to you!

10.2 Stopping the motor

After the finished navigation, place the handle of the control console into the neutral position. By doing so, you stop the rotation of the propeller.

10.3 Vessel equipment care

After the finished navigation, all the equipment must be dried (including the life jackets, the ropes, the fenders, paddles and anything else you might want to keep in the storage compartments on the vessel). When the equipment is dry, store it in the compartments on board the vessel, otherwise the humidity on the stored objects will create mould, the objects will oxidise and become useless.

10.4 Switching off the current-using equipment

Make sure you switched off all the current-using equipment before you leave the vessel, but most importantly, both main switches must be in the „OFF“ position. Failure to switch off the equipment could lead to an error on the electrical installation and provoke a fire on the vessel.

10.5 Vessel protection

Once you have completed all of the above mentioned guidelines, all that remains to be done is to lower the roof with the remote control in order to protect the vessel from the weather and unwanted visitors. Before you actually leave the vessel, check another time that the vessel is correctly and firmly tied to the pier or firmly anchored. If the vessel is anchored, check the position of the vessel regularly, so that if the anchor is „plowing“ the floor, the vessel will not go too far from the anchoring spot.

11 MAINTENANCE

11.1 Cleaning and servicing the vessel

The vessel Energy18 requires regular maintenance in order to work as long as possible. The basic tasks can be carried out by you, without any special knowledge.

It is very important that:

- you regularly clean the vessel. Use mild cleaning products, similar to those used for washing cars. Do not use any aggressive cleaning products or acids. If you need any advice, please turn to the vessel's manufacturer, representative or the nearest shop which sells nautical equipment.
- The pillows should be maintained with the adequate means, otherwise, they will lose their firmness and become damaged due to sun radiation and humidity.
- Check the vessel regularly in order to find any damages to the hull, the propeller or the equipment on board in time.
- Before charging the batteries, check the feeder cable for any damages.
- Before charging the batteries, check if the battery clamps are oxidised. If they are, you need to clean them and recover them with silicone grease.

11.2 Lifting the vessel

When lifting the vessel, you need to be careful that the lifting straps are attached to the designated areas, which are indicated with special markings on the vessel's hull. In the event of an inadequate attachment of the lifting straps, the vessel could lose balance and slip off the lifting straps. As a result, the vessel would fall to the ground and be ruined.

11.3 Vessel and equipment protection

Most of the time your vessel is in water and exposed to humidity and bad weather, therefore, the vessel and its equipment are also exposed to oxidation, algae, dirt and other inconveniences. This chapter describes how to prevent these inconveniences.

Algae on the hull

The gathering of algae on the vessel under the waterline presents a great resistance and therefore it reduces the vessel's autonomy. If this occurs, it is necessary to lift the vessel out of the water and clean the hull. In order to prevent the growth of algae in the hull, you can use special products and paints. Before deciding on this procedure, consult the manufacturer or authorized service centre about choosing the right protective substance and procedure. Inadequate protective substances or procedures can ruin the hull and therefore create more damages than benefits!

Metal parts

Because the vessel is most of the time in water and moisture, is very important, that all metal parts mounted on vessel (eg. hydraulic cylinder, cleat, flagpole) are regularly

inspected and cleaned. If you see any damage, it is necessary to immediately replace it with a new one. If you find traces of corrosion, you need to clean the metal part with soft cloth and polishing paste which you received with the vessel.

Metal equipment can't in any way be cleaned with any scrapers, metal brushes or meshes.

Stainless surfaces

Even the stainless and chrome surfaces are not entirely resistant to corrosion and can damage during a prolonged exposure to water and especially hoarfrost. It is possible to prolong the lifespan of the mentioned parts with regular cleaning and adequate maintenance. When you notice any damage, replace the damaged component with a new one. Damaged components and equipment on the vessel can present a danger for the passengers and other participants in traffic.

Cleaning the vessel

As mentioned before, a prolonged exposure to water, dirt and weather damages the vessel and its equipment. Therefore, it is very important to regularly clean all the components of the vessel with adequate mild cleaning products and freshwater. The carpets and pillows must be cleaned with a vacuum cleaner. The vessel is made of reinforced fiberglass, which means that its maintenance and cleaning are not difficult. After cleaning the vessel, it is also important to apply to the components adequate products (protective creams for leather, wood, plastic, rubber etc.). Maintaining the vessel is similar to maintaining your car. It requires regular cleaning.

Never use aggressive cleaning products, such as acids or diluters. In the event of a warranty claim, for which it would be determined that the components or the equipment were damaged due to an inadequate maintenance or use of inadequate cleaning products, the warranty shall not be allowed. The warranty conditions do not apply for such circumstances.

11.4 Regular servicing

The vessel Energy18 does not require special servicing, it only needs regular cleaning and maintenance. The same does not apply for the motors and batteries. To know which regular servicing are needed and in which intervals, please consult the user guides issued by the manufacturers of the mentioned components.

11.5 Storing the vessel in winter

Storing the vessel in winter, when the vessel is not used for a prolonged time, requires special preparations. This is also the period when you have the chance to lift the vessel out of the water and carry out thorough checks and maintenance of the vessel and its equipment. If the said period is longer, it is also advisable to remove the batteries from the vessel and store them in a warmer place, where it would also be easier to recharge them, thus reducing the level of discharge. Before exposing the vessel to the temperatures below

freezing point, it is necessary to check that the vessel does not contain any water (in pumps, reservoirs, storing surfaces etc.), as it would damage the said parts in the event of freezing. Damages of the vessel's components, caused by freezing water is not included in the warranty conditions. You also need to take into account the guidelines on storing during winter, which are mentioned by the manufacturers of the motor and other installed equipment in their user guides.

The most important tasks before the winter storage:

- pump out all the water from the hull,
- empty the water pump which you used to remove the water from the hull,
- clean the hull thoroughly,
- clean the deck thoroughly,
- clean the interior of the vessel thoroughly,
- air and leave to dry the vessel and its equipment for a few days,
- apply the protective wax to the hull,
- if possible, remove the batteries from the vessel and keep them in a dry and dark place (storage or garage), recharge them,
- make sure that the roof is completely lowered. For a better insulation, you can apply between the roof and the hull an insulation foam with the diameter of 5 cm, which is also used for insulating the heating pipes. .

11.6 After the winter storage

What you need to do after winter and before the first navigation:

- check that the batteries are fully charged,
- check that the control system is working properly,
- follow the guidelines of the motor manufacturer about the first ignition after the winter storing. As this requires special skills, you can ask for assistance or advice the authorized service centre or the vessel's manufacturer.
- Check all the storing surfaces, the motor and battery area, as well as other similar hidden parts of the vessel, to make sure that any parasites or other animals did not inhabit these parts during winter.
- Check the oil level of the motor,
- check for any damages to the motor, the water pump and the sliding roof due to freezing,
- check the attachment of the cleats and other parts used for tying and anchoring the vessel,
- check that the propeller and its rotation are flawless.

12 SERVICING

In the event of damages or if servicing is necessary due to other reasons, please turn to the manufacturer of the vessel Energy18 or the store where you bought the vessel. In order to find the nearest store, visit the website www.alfastreet-marine.si, call the number +386 5 70 72 100, or send us and email to the address info@alfastreet.si.

If you are not satisfied with the servicing:

- consult the person authorized for servicing at the place where the vehicle was repaired on matters related to the warranty,
- if the authorized service centre does not repair the error in the determined period of time, or if you are not satisfied with the service, turn to the manufacturer.

Every owner of the vessel must be aware that regular servicing and maintenance are necessary to guarantee a long lifespan of the vessel and, most importantly, to guarantee a safe navigation. Ask the manufacturer or supplier for an offer on regular services or maintenance of your vessel. If you own a large number of vessels and you have your own service team, the manufacturer or its representative can organize a training course for your colleagues in order to enable them to undertake almost all service tasks on their own.

Alfastreet Marine also offers “on-line” support for any questions about maintenance and servicing of the vessel Energy-18:

Service centre Alfastreet-marine:

Dejan Ravbar

Partizanska 129, 6211 Sežana Si (Slovenia)

tel. n.: +386 5 7072 115

email: dejan.ravbar@alfastreet.si