



# High-Voltage Circuit-Breakers 3AP1/2 72.5 kV up to 550 kV

Answers for energy.

**SIEMENS**



# The 3AP1/2 High-Voltage Circuit-Breakers Now Applicable for 550 kV

Decades of our experience in high-voltage switching technology go into the design and production of the 3AP1/2 circuit-breakers which set an international trend. We are a powerful partner for our customers and a competent supplier of attractive products and solutions at competitive prices with the high standard of quality that Siemens is known for. We comply with our customers' demands for reliability, safety and cost-effectiveness and serve them throughout the world. No matter what your application is, the 3AP1/2 circuit-breakers provide the best solution for your requirements every time.

**Our standard is reliability and safety at all times**

The 3AP1/2 circuit-breaker family is available for rated voltages from 72.5 kV up to 550 kV. The latest development of our well established circuit-breakers completes our 3AP product range for rated voltages up to 550 kV. For the application of 362 kV to 550 kV the circuit-breakers can be equipped with optional closing resistors. The circuit-breakers feature approved technology and ensures efficient operation. Based on our well proven modular design, we manufacture all of the core components ourselves, which include the stored-energy spring mechanism and the arc-assisted interrupter unit.

More than **50,000 3AP-circuit-breakers** have been **delivered to over 120 countries** around the world in all climatic areas, proving on a daily basis the value and the reliability of the 3AP high-voltage switchgear. The 3AP1/2 high-voltage circuit-breaker operates safely and is capable of withstanding high mechanical loads. Particularly strong porcelain insulators and a circuit-breaker design optimized by using the latest mathematical techniques, give it very high seismic stability whilst in operation enabling it to perform to its full potential during its entire service life.



**3AP2 FI 420 kV**  
Live-tank circuit-breaker  
in operation at a major  
power transmission and  
distribution company

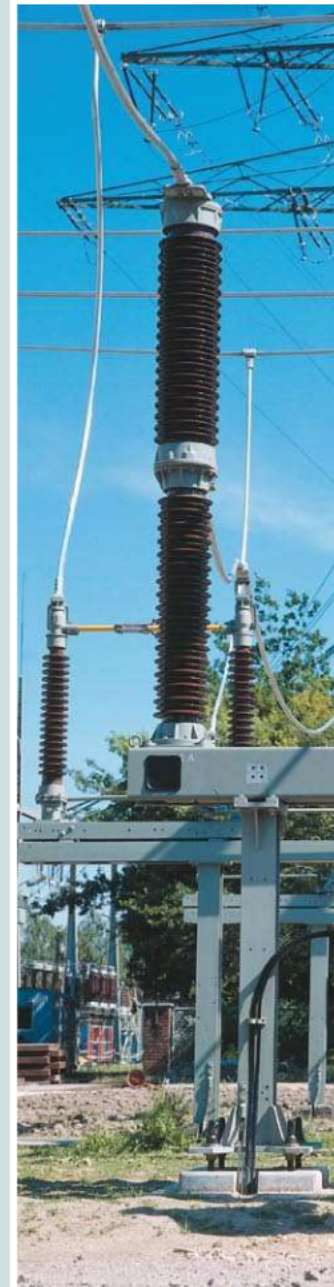



# With High-Voltage Circuit-Breakers from Siemens you are always on the Economically Safe Side



3AP1 FG 145 kV Live-tank circuit-breaker

## Great demands for highest quality

Our quality management system, certified in accordance with DIN EN ISO 9001, confirms that our quality always remains at the same high level. We carry out regular management reviews, internal audits in every department and the continuous development and maintenance of documentation for all processes. Most modern manufacturing technologies and investments in our worldwide production sites, assure reliable and **long-lasting products and process quality** according to Siemens' well-proven high standards.

The high quality, as well as excellent operating experience, is inherited by the 3AP series. The result is very high SF<sub>6</sub> tightness of our switchgear: **The SF<sub>6</sub> leakage rate is less than 0.5% per year.** This not only increases reliability and decreases operating costs as a result of long maintenance intervals, but also has a positive impact on the environment, indicating our sense of responsibility. Our switchgear will fulfill your demands for low life-cycle-costs with highest availability and economical and continuous operation. We use strong materials under low mechanical loads in the construction of individual switchgear components, therefore **maintenance is not needed for 25 years or 10,000 operating cycles.** By standardizing our internal processes and systematically implementing module strategies for our 3AP product series, we can offer minimal **delivery times.**

The results are low service and investment costs which provide our customers competitive advantages worldwide, which equates to greater success for their own businesses.

# The Modular Design



**The self compression arc-quenching principle is applied in our 3AP circuit-breakers.**

The arc-assisted interrupter unit of the 3AP circuit-breaker utilises the energy of the arc during opening for an optimal arc quenching, allowing to reduce the operating energy to a minimum. Our circuit-breakers for the voltage range 72.5 kV up to 300 kV have one interrupter unit per pole and up to 245 kV the circuit-breakers are available with a common or a single-pole operating mechanism. 3AP high-voltage circuit-breakers from 362 kV up to 550 kV are equipped with two interrupter units per pole.

**The stored-energy spring mechanism**

The compact design of this operating mechanism allows to place the stored-energy spring mechanism within the control cubicle. The main components such as the interrupter unit and the operating mechanism of our 3AP1/2 high-voltage circuit-breakers, are identical to the ones in our 3AP deadtank circuit-breaker family. By applying this proven modular design we can fulfill the highest expectation with regard to availability, reliability, as well as economical performance. This results in continuously high customer satisfaction.

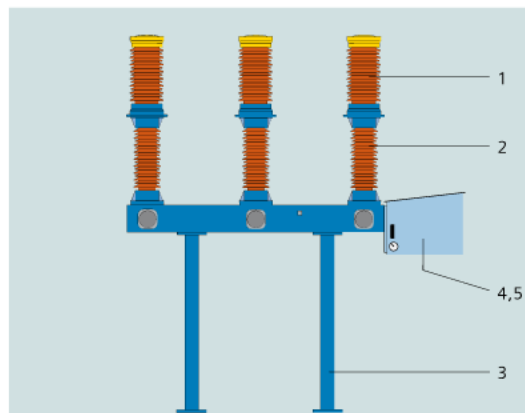

**3AP1 FG up to 72.5 kV**  
One interrupter unit per pole.

Laterally stored-energy spring mechanism, circuit-breaker with common breaker base for three-pole operation

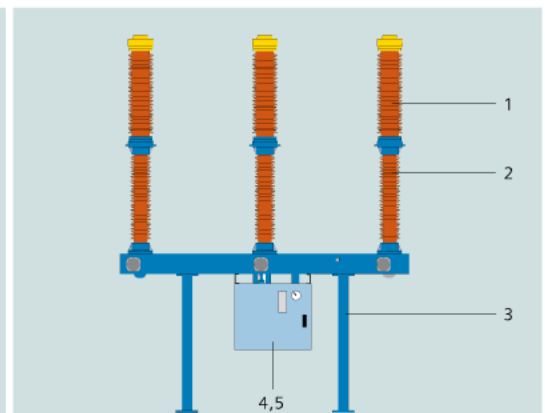

**3AP1 FG up to 245 kV**  
One interrupter unit per pole.

Stored-energy spring mechanism, circuit-breaker with common breaker base for three-pole operation

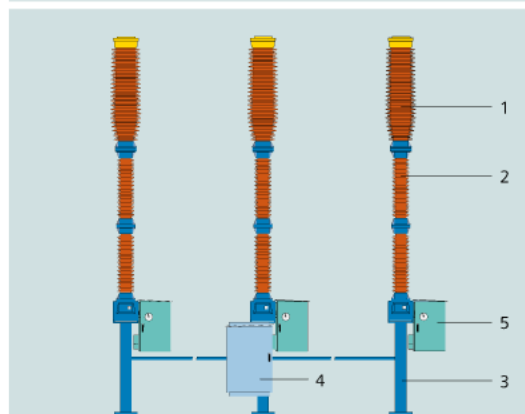

**3AP1 FI up to 300 kV**  
One interrupter unit per pole.

Stored-energy spring mechanism, three-pole breaker with separate breaker base for one or three-pole operation

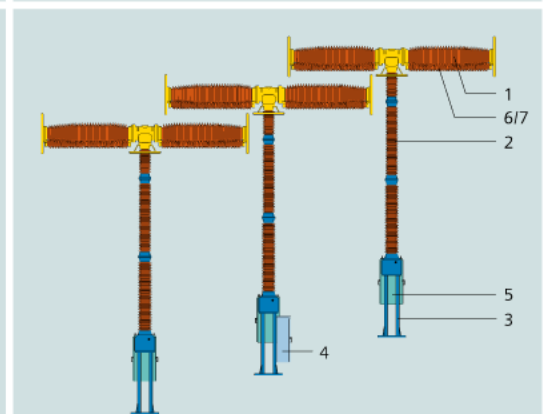

**3AP2 FI up to 550 kV**  
Two interrupter units per pole.

Stored-energy spring mechanism, circuit-breaker with separate breaker base for one or three-pole operation

3AP circuit-breakers are available in different designs

- 1 Interrupter unit
- 2 Post insulator
- 3 Pillar
- 4 Control cabinet
- 5 Operating mechanism cubicle
- 6 Grading capacitor
- 7 Closing resistor (optional)



# The Quenching Principle

## The conducting path

The current conducting path of the interrupter unit consists of the contact carrier (1), the base (6) and the moveable contact cylinder (5). In the closed position, the current flows via the main contact (2) and the contact cylinder (5).

## Breaking operating currents

During the opening operation, the main contact (2) opens first, and the current commutates to the still closed arcing contact. During the further course of opening the arcing contact (3) opens and an arc is drawn between the contacts. At the same time, the contact cylinder (5) moves into the base (6) and compresses the SF<sub>6</sub> gas located there. This gas compression creates a gas flow through the contact cylinder (5) and the nozzle (4) to the arcing contact extinguishing the arc.

## Breaking fault currents

In the event of interrupting high short-circuit breaking current, the SF<sub>6</sub> gas is heated up considerably at the arcing contact due to the energy of the arc. This leads to a pressure increase in the contact cylinder. During the further course of opening this increased pressure initiates a gas flow through the nozzle (4) extinguishing the arc. In this case, the arc energy is used to interrupt the fault circuit breaking current. This energy needs not to be provided by the operating mechanism.

## The interrupter unit of the 3AP circuit-breaker is very efficient

A fixed arcing contact is used for rated voltages up to 145 kV. This results in a reduced number of mechanical parts in the interrupter unit.

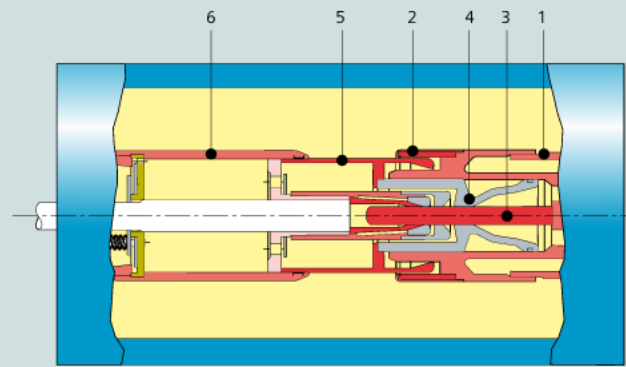

Closed position

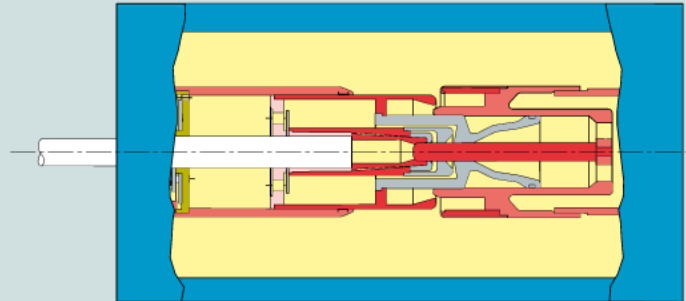

Opening: main contact in open position

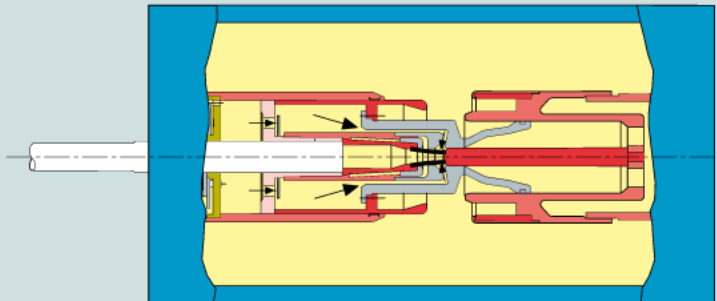

Opening: arcing contact in open position

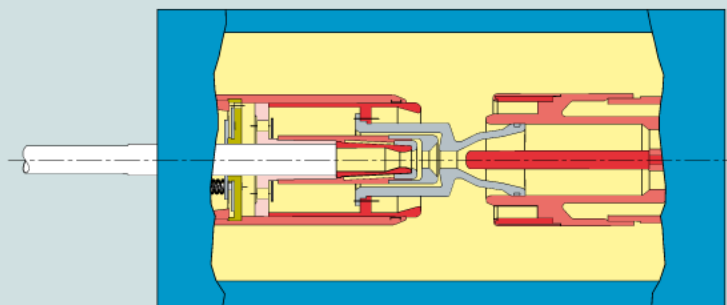

Open position

- 1 Contact carrier
- 2 Main contact
- 3 Arcing contact
- 4 Nozzle
- 5 Contact cylinder
- 6 Base

# The Stored-Energy Spring Mechanism

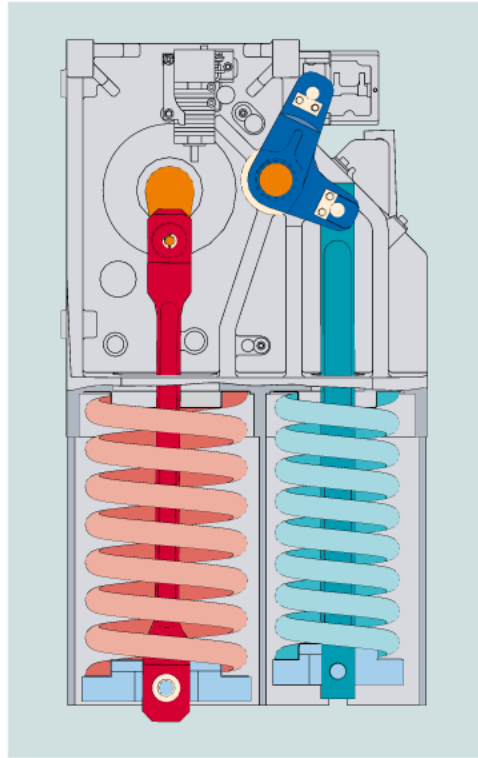

The advantages of the stored-energy spring mechanism:

- Same principle for rated voltages from 72.5 up to 550 kV
- High reliability thanks to low operating energy
- Simple principle of operation
- Controllable switching state at all times
- Low maintenance, economical and long lifetime
- Low environmental impact

## There are a number of advantages to our stored-energy spring mechanism

Compact housing can be utilized by applying the most modern production techniques. Since the closing and opening springs are housed in the operating mechanism, a compact and sturdy structure is achieved.

This design results in a small number of moving parts. The use of roller bearings and the maintenance-free spring mechanism are a prerequisite for decades of reliable operation. Proven design principles such as vibration-isolated latches and load-free isolation of the charging mechanism are retained.

- 1 Trip coil CLOSE
- 2 Cam plate
- 3 Corner gear
- 4 Connecting rod
- 5 Connecting rod for closing spring
- 6 Connecting rod for opening spring
- 7 Closing spring
- 8 Emergency hand crank
- 9 Charging gear
- 10 Charging shaft
- 11 Roller lever
- 12 Damper (for closing)
- 13 Operating shaft
- 14 Damper (for opening)
- 15 Trip coil OPEN
- 16 Drive mechanism housing
- 17 Opening spring

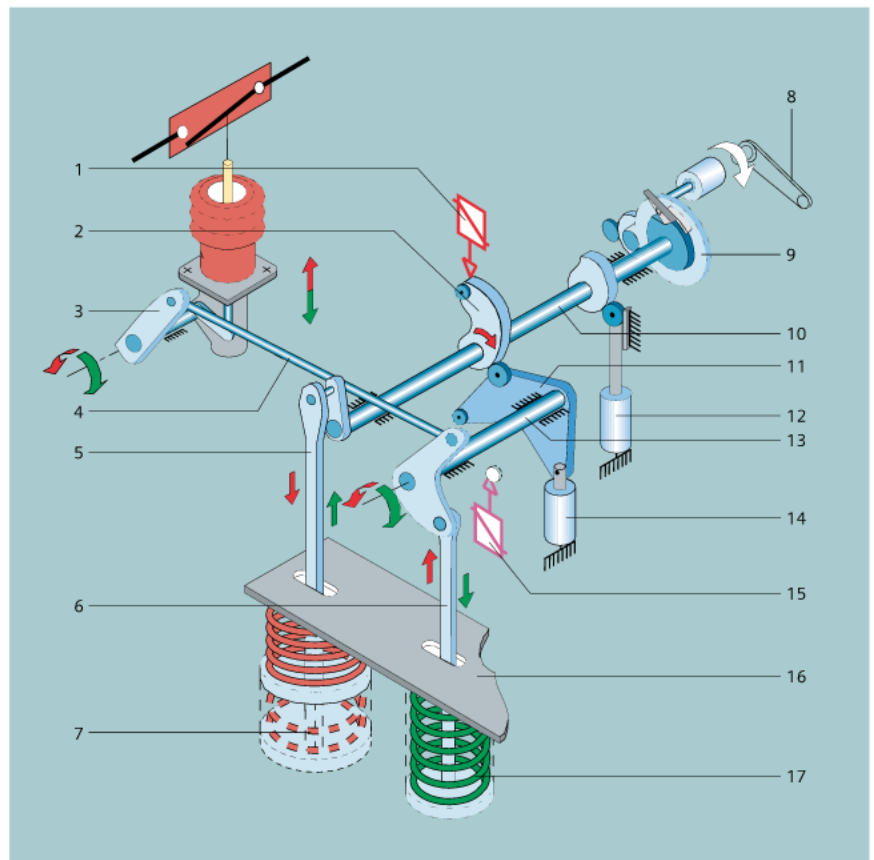



# The Control

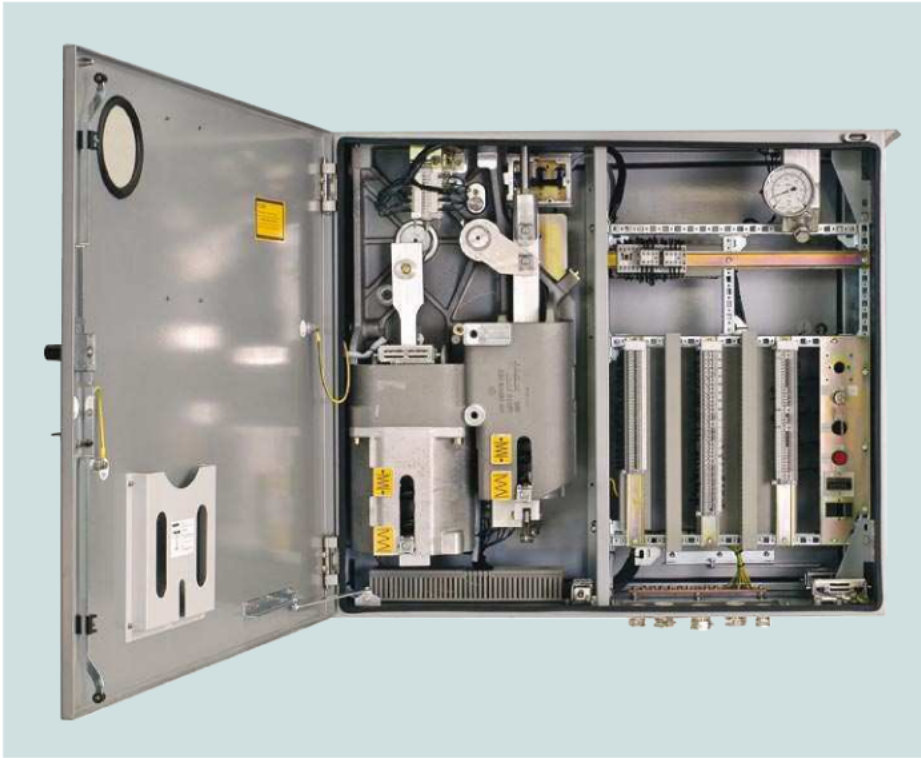

Control cabinet with the stored-energy spring mechanism

The control system includes all the secondary components required for operating the circuit-breaker, most of them are located in the control cabinet. The control, tripping, motor and heating power supplies are, to a great extent, selectable. Depending on customer requirements, two standard control variants are available.

## Basic variant

The basic variant includes all control and monitoring elements that are needed for operation of the circuit-breaker. In addition to the elementary actuation functions, it includes:

- 19 auxiliary switch contacts (9 normally open, 9 normally closed, 1 wiper contact)
- Switching operation counter
- Local actuator

## Compact variant

In addition to the basic variant, this variant includes:

- Spring monitoring by motor run time monitoring
- Heating monitoring (current measuring relay)
- Light and socket with a common circuit-breaker
- Overvoltage attenuation
- Motor circuit-breaker
- Heating circuit-breaker

## Special features

Above and beyond these two standard variants, a great number of further components and options are at our customers' disposal. Every control configuration of a circuit-breaker can therefore **be designed individually**. All control components have been type-tested for use on our circuit-breakers and are all located in a weatherproof cubicle (IP 55 degree of

protection). They are resistant to switching vibrations, and meet the requirements for electromagnetic compatibility (EMC).

The circuit-breaker documentation includes the wiring diagram of the control configuration. This diagram comprises the following documents:

- Location diagram
- Circuit diagram
- Technical data equipment part list
- Connection diagram

The circuit diagram documentation is bilingual in one common customer specific language and in German.

# Quality Right from the Start



3AP2FI 550 kV Live-tank circuit-breaker in our high-voltage testing laboratory

## Development

The foundation for the quality of Siemens high-voltage circuit-breakers is laid down right from the beginning of the development of a new product. Switching performance, high-voltage stability and performance under mechanical loads (wind and short circuits) and during an earthquake are simulated and optimized in the outline design phase using computer-aided calculations.

The use of common parts and assembled units in a large number of breaker types such as live-tank, dead-tank, as well as in the GIS means the production of a large number of the same type of main components. Steady and regular quantities of produced units allow a continuous production process and ensure the highest quality standards. Statistic quality control is based on large quantities. This results in a higher achieved validity.

All 3AP1/2 circuit-breakers can be used in earthquake areas up to 0.5 g without additional fittings.

## Testing laboratories

Our Berlin circuit-breaker plant has the most modern testing laboratories and offers all required facilities:

- Physics laboratory
- High-voltage testing laboratory
- Switching performance testing laboratory
- Mechanical testing laboratory
- Temperature rise testing laboratory

The testing laboratories are certified by the German accreditation body Technik e.V. in accordance with DIN 45001. With the society for electrical high-power tests (PEHLA), the testing laboratories are part of the European network of independent testing organizations (STL). The 3AP1/2 circuit-breakers are fully type tested in accordance with the new IEC 62271-100 and ANSI-Standard.

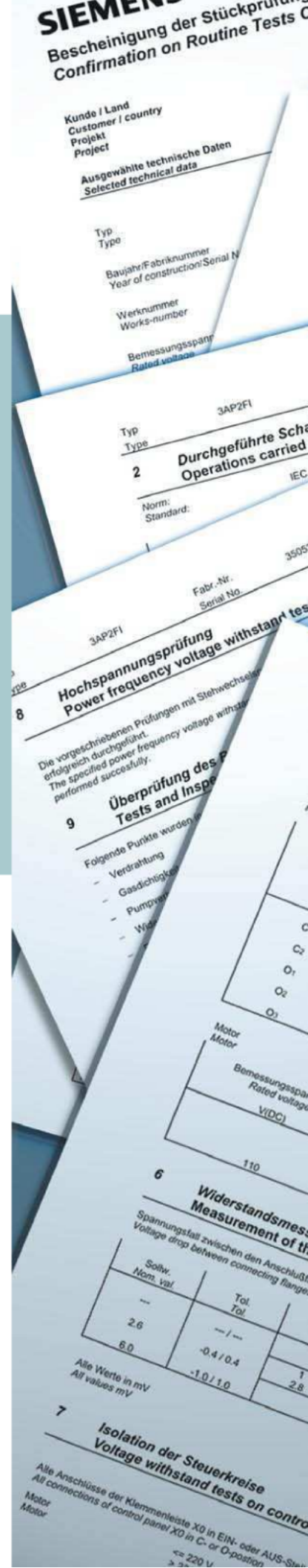





### Routine testing

The main components of the circuit-breakers are subjected to complete pre-acceptance testing before assembly. Based on this quality level, it is possible to confirm a leakage rate of less than 0.5% per year for the circuit-breaker. Each circuit-breaker is completely assembled in the test bay. The product specific inputs for computer-assisted routine testing are imported automatically from the order processing tools. This ensures that in addition to the standard test procedure the fulfillment of every customer requirement is checked before delivery.

Routine testing is performed in accordance with the IEC- or ANSI-standards and it includes at least the following operations and measurements:

- Series of 100 mechanical switching cycles
- Switching time determination
- Release and motor currents
- Gas monitoring
- Testing of control circuits in accordance with the circuit diagram
- Voltage drop of the main conducting path
- High voltage tests

# Installation – Simply Easy

## Installation and commissioning

The circuit-breaker is dismantled into few subassemblies for transportation. Transportation costs are minimized by using a very compact transport unit and by packing several circuit breakers together into one transportation unit. The subassemblies can be quickly assembled into a complete circuit-breaker on site.

The 3AP circuit breakers can be installed by a single installation fitter.

No special tools are required.

## Service offered by the manufacturer to the operator

Throughout the entire service life of the circuit-breaker we provide installation and commissioning and any other services on request.

The first visual inspection of the circuit-breaker is not necessary within 12 years, and the first **maintenance** is recommended **after 25 years**.

Depending on customer requests, different diagnostic tools can be offered.

A worldwide **24 hours service** is available, which immediately sends out service personnel and/or delivers spare parts as needed.

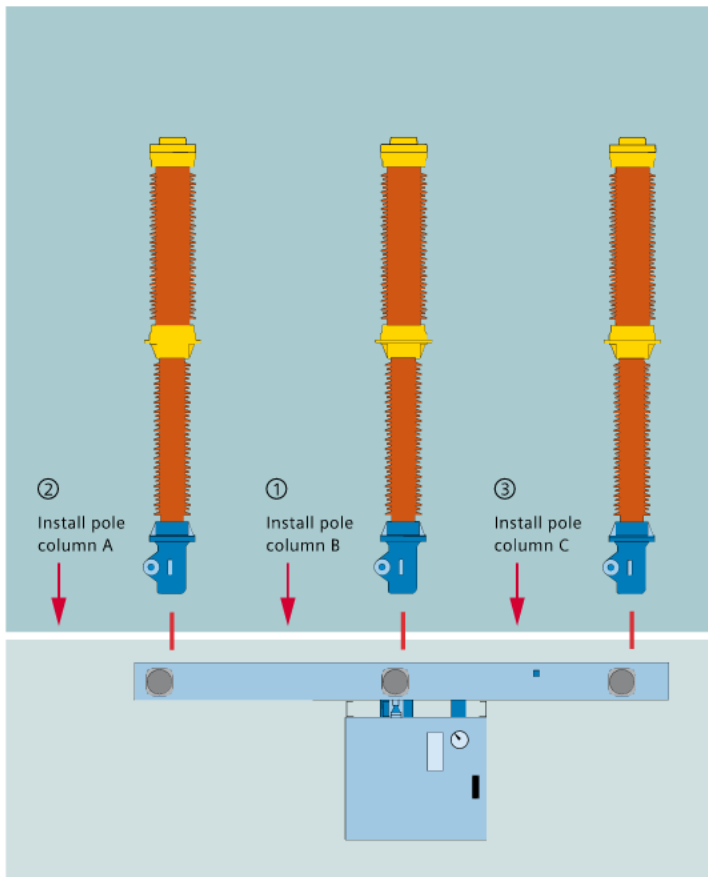

■ 3AP1  
one working day

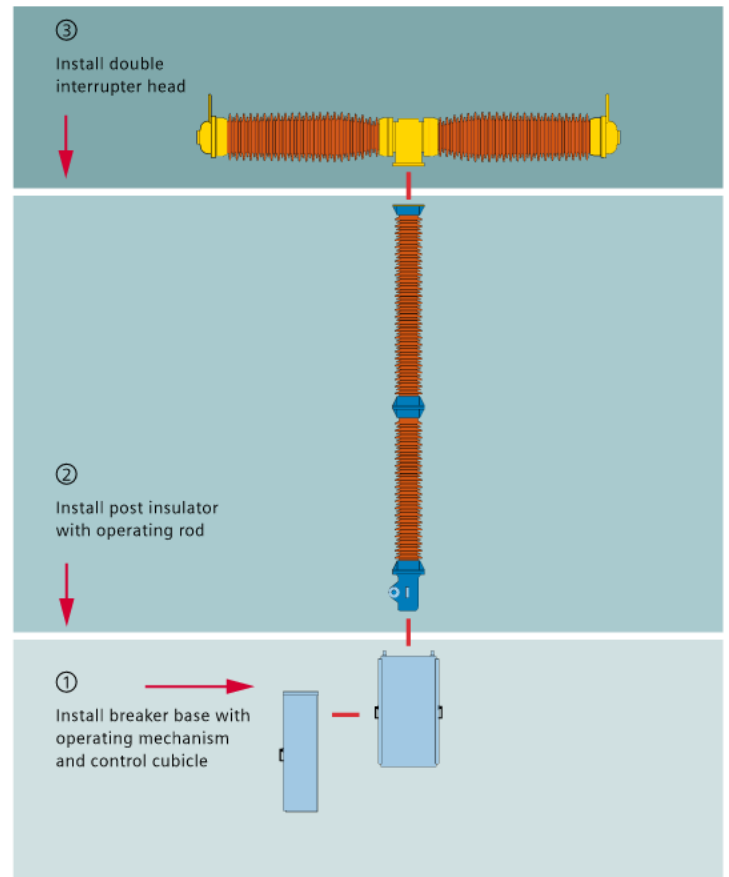

■ 3AP2  
two working days



# Technical Data

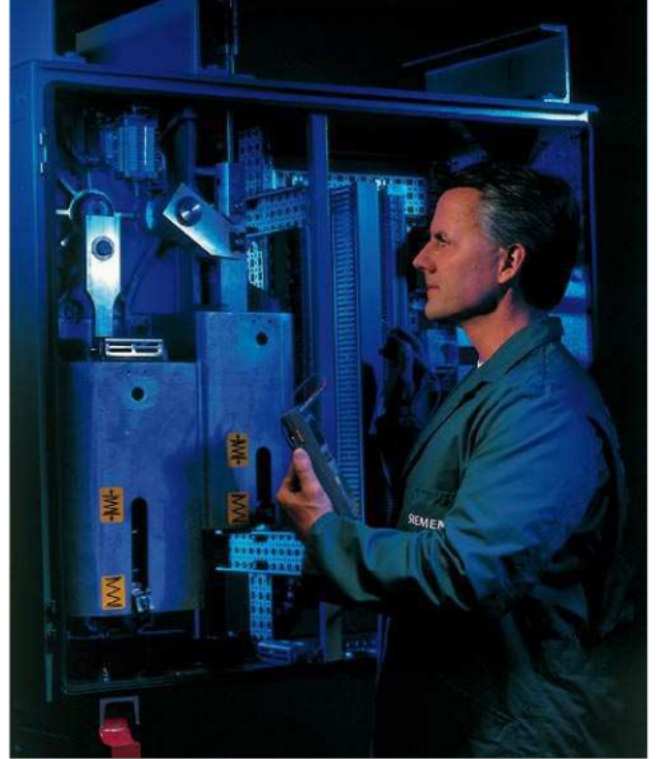

Type		3AP1						3AP2			
Rated voltage	kV	72.5	123	145	170	245	300	362	420	550	
Number of interrupter units per pole		1						2			
Rated power frequency withstand voltage/min	kV	140	230	275	325	460	460	520	610	800	
Rated lightning impulse withstand voltage/min	kV	325	550	650	750	1050	1050	1175	1425	1550	
Rated switching impulse withstand voltage	kV	850						950	1050	1175	
Rated normal current, up to	A	4000	4000	4000	4000	4000	4000	5000	5000	5000	
Rated short-time withstand current (1 s - 3 s), up to	kA <sub>(rms)</sub>	40	40	40	40	50	40	63	63	63	
Rated peak withstand current, up to	kA <sub>(peak)</sub>	108	108	108	108	135	108	170	170	170	
Rated short-circuit breaking current, up to	kA <sub>(rms)</sub>	40	40	40	40	50	40	63	63	63	
Rated short-circuit making current, up to	kA <sub>(peak)</sub>	108	108	108	108	135	108	170	170	170	
Temperature range	°C	-30 or -40 ... +40 or +50									
Rated operating sequence		0-0.3 s-CO-3 min-CO or CO-15 s-CO									
Rated break time		3 cycles						2 cycles			
Rated frequency	Hz	50/60									
Type of drive mechanism		Stored-energy spring mechanism									
Control voltage	V <sub>DC</sub>	48...250									
Motor voltage	V <sub>DC</sub>	48/60/110/125/220/250									
	V <sub>AC</sub>	120...240, 50 Hz; 120...280, 60 Hz									
Flashover distance	phase/earth	mm	700	1250	1250	1500	1900	2200	3400	3400	3800
	across open breaker	mm	1200	1200	1200	1400	1900	2200	3200	3200	3800
Min. creepage distance	phase/earth	mm	2248	3625	3625	4250	6125	7626	10375	10375	14450
	across open breaker	mm	3625	3625	3625	4250	6125	8575	10500	10500	15126
Dimensions	height	mm	3810	4360	4360	4810	6050	6870	6200	6200	7350
	width	mm	3180	3880	3880	4180	6640	8235	8847	9847	13050
	depth	mm	660	660	660	660	880	880	4380	4380	5050
Phase spacing (min.)	mm	1350	1700	1700	1850	2800	3600	4000	4500	6000	
Circuit-breaker mass	kg	1350	1500	1500	1680	2940	3340	5370	5370	7160	
Maintenance after		25 years									

Values in accordance with IEC, other values available on request

# For further Information

Please fax this page  
to the following number:

Fax **+91 240 2554 701**

or send us an e-mail:

**circuit-breaker@siemens.com**

Name

Position

Company

Street

Postcode/City/Country

Phone/Fax

**Please send me more information on the following topics:**

- High-voltage circuit-breakers for outdoor installation
- Live-tank and dead-tank high-voltage circuit-breakers technology
- High-voltage compact switchgear 3AP1 DTC for 145 kV and 245 kV
- Eliminate stress: Controlled switching of high-voltage circuit-breakers
- SF<sub>6</sub> in power engineering – acting responsibly
- Ruhrtal – Disconnectors and Earthing Switches
- Further copies of this brochure

Published by and copyright © 2009  
Siemens AG  
Energy Sector  
Freyeslebenstrasse 1  
91058 Erlangen, Germany

[www.siemens.com/energy](http://www.siemens.com/energy)  
[www.hv-circuit-breaker.com](http://www.hv-circuit-breaker.com)

Siemens Ltd  
Energy Sector  
High Voltage Breakers

E-76, Waluj MIDC,  
Aurangabad - 431 136  
Maharashtra - India

For more Informations please contact our  
Customer Support Center.

Email: [support.energy@siemens.com](mailto:support.energy@siemens.com)

Order No. E50001-G630-A132-X-4A00-XX  
Mu. PA 0309X.X

Printed on elementary chlorine-free bleached paper.

All rights reserved.  
Trademarks mentioned in this document are the property of  
Siemens AG, its affiliates, or their  
respective owners.

Subject to change without prior notice.

The information in this document contains general descriptions  
of the technical options available, which may not apply  
cases. The required technical options should therefore be  
specified in the contract.