

Important Information



WARNING

This User's Manual contains safety information and instructions for your trailer. You must read this manual before loading or towing your trailer. You must follow all safety precautions and instructions.

Loss of control of the trailer or trailer/tow vehicle combination can result in death or serious injury. The most common causes for loss of control of the trailer are:

- Driving too fast for the conditions (maximum speed when towing a trailer is 60 m.p.h.);
- Overloading the trailer or loading the trailer unevenly;
- Trailer improperly coupled to the hitch;
- No breaking on trailer;
- Not maintaining proper tire pressure;
- Not keeping lug nuts tight; and
- Not properly maintaining the trailer structure.

A user's manual that provides general trailer information cannot cover all of the specific details necessary for the proper combination of every trailer, tow vehicle and hitch. Therefore, you must read, understand and follow the instructions given by **the tow vehicle** and trailer hitch manufacturers, as well as the instructions in this manual.

Trailer Components

Our trailers are built with components produced by various manufacturers. Some of these items have separate instruction manuals. Where this manual indicates that you should read another manual and you do not have that manual, call 1-800-348-7530 for a free copy.

Commitment to Quality

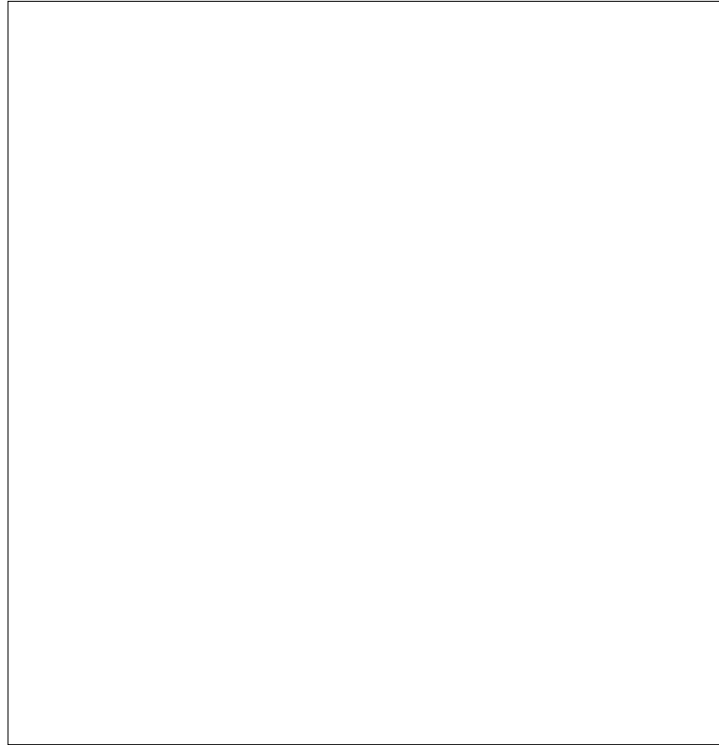

For over twenty years Haulmark has constructed the best-built trailers in America. We recognize and value the importance of strength, durability and quality and strive to give our customers nothing less.

We realize that in addition to receiving a quality product, you expect good service after the sale. That is why in addition to receiving a high-quality product, you are given a 3-year limited warranty that's unmatched by any other trailer manufacturer.

At Haulmark, our well-trained warranty and service department is always available to provide customers with quick, courteous and reliable service. Another reason why Haulmark is "the best name behind you for the long haul."

Mike Arnold
President
Haulmark Industries, Inc.

Important Information

Haulmark Industries, Inc. provides you with a 3-year warranty which gives you specific legal rights. Please be sure that you read and understand our Warranty.

Limited Warranty

Haulmark Industries, Inc., P. O. Box 281, Bristol, IN 46507 (Warrantor) warrants to the ORIGINAL CONSUMER PURCHASER (PURCHASER) for a period of THREE (3) YEARS from the date of purchase by PURCHASER (WARRANTY PERIOD), that its trailer (the PRODUCT) shall be free of DEFECTS in materials and workmanship attributable to Warrantor.

Excluded from this three year Warranty are electrical, plumbing, windows, doors, seals, sealant, paint, undercoating and fiber-glass parts which are warranted for a ONE (1) YEAR period from the date of purchase by the Original Purchaser.

THINGS EXCLUDED FROM WARRANTY

Warrantor is not responsible for claims relating to the following: (1) trailer rental; (2) defacing: scratches, dents, chips, tears and defacing on any surface not caused by Warrantor; (3) routine maintenance; (4) damage from unauthorized repairs, abuse, misuse or neglect; (5) damage caused by improper hitch ball or tow vehicle hook up; (6) vibration, water damage, freezing, breakage, or other damage to the contents of any trailer, regardless of cause. (7) component parts covered by separate Supplier Warranty such as warranties of the manufacturer of tires, axles, jacks, couplers, windows, light fixtures, etc. These warranty claims must be presented to their respective component manufacturer for warranty service. Haulmark Industries, Inc. reserves the right for final determination whether or not the product has been abused or misused by the Purchaser.

WARRANTOR'S OBLIGATION-HOW TO GET WARRANTY SERVICE

Warrantor shall elect to remedy defects in materials and workmanship caused by Warrantor by repair, replacement or refund, if replacement or repair is not possible. All defective products shall be delivered to Warrantor's address listed above unless prior written approval is obtained from Warrantor. Warrantor may, as its option, select another qualified location for the repair to be completed. Warrantor will not be obligated, in any way, to pay for any repairs made without its specific approval. All costs incurred in shipping or delivered the products for warranty service shall be borne by the Purchaser. Warrantor shall remedy defects within a reasonable time, not to exceed sixty (60) days after delivery by Purchaser.

PURCHASER'S OBLIGATIONS

Purchaser must notify the Warrantor, at the above address, of any defect within fifteen (15) days after it is , or should have been, discovered. Purchaser must complete and return to Warrantor the attached Warranty Card within fifteen (15) days of purchase to obtain warranty service. Purchaser must pay all service, towing and transportation charges incurred to obtain warranty service.

DISCLAIMER OF CONSEQUENTIAL AND INCIDENTAL DAMAGES

THE ORIGINAL PURCHASER OF WARRANTOR'S PRODUCT AND ANY PERSON TO WHOM THE PRODUCT IS TRANSFERRED, AND TO ANY PERSON WHO IS AN INTENDED USER OR BENEFICIARY OF THE PRODUCT SHALL NOT BE ENTITLED TO RECOVER FROM WARRANTOR ANY CONSEQUENTIAL OR INCIDENTAL DAMAGES RESULTING FROM ANY DEFECT IN THE PRODUCT. DAMAGES INCLUDE LOSS OF USER OF TRAILER, LOSS OF USE OF TRAILER, DAMAGE TO CONTENTS OF THE TRAILER, LOSS OF REVENUES OR ANY OTHER COMMERCIAL LOSSES, SUBSEQUENT USE OF RENTAL EQUIPMENT, LOSS OF TIME AND INCONVENIENCE.

Some states do not allow for the exclusion or the limitation of incidental or consequential damages, so the above limitation or exclusion may not apply to you.

LIMITATION AND DISCLAIMER OF IMPLIED WARRANTIES

WARRANTOR EXPRESSLY LIMITS THE DURATION OF ALL IMPLIED WARRANTIES OF MERCHANTABILITY, ALL IMPLIED WARRANTIES OF FITNESS FOR A PARTICULAR PURPOSE AND OTHER IMPLIED WARRANTIES TO THE WARRANTY PERIOD OF THREE (3) YEARS. THE WARRANTOR EXPRESSLY DISCLAIMS ALL IMPLIED WARRANTIES OF MERCHANTABILITY AND ALL IMPLIED WARRANTIES OF FITNESS FOR A PARTICULAR PURPOSE AFTER EXPIRATION OF THE WARRANTY PERIOD. There is no warranty made by Purchaser beyond that contained in this warranty. No person has the authority to enlarge, amend or modify this Warranty.

DESIGN CHANGES

Warrantor reserves the right to change the design of its products from time to time without notice and with no obligation to make corresponding changes in its products previously manufactured.

LEGAL REMEDIES OF PURCHASER

THIS WARRANTY GIVES YOU SPECIFIC LEGAL RIGHTS, AND YOU MAY HAVE OTHER RIGHTS WHICH MAY VARY FROM STATE TO STATE. No action to enforce this Warranty shall be commenced later than six (6) months after the discovery of any defect or after the expiration of the Warranty Period.

About Your Manual

Although your Haulmark trailer was built to be "the best name behind you for the long haul", there are several maintenance steps you must take to ensure that your trailer looks and pulls as well as the day you brought it home.

This manual outlines the basic components of your trailer as well as provides you with guidelines to follow for proper maintenance. Simple instructions are given for the care of electrical systems, brakes, wheels, bearings and hitches. If you have any questions about your trailer contact either your dealer or Haulmark.

Please keep this booklet in your tow vehicle and refer to it often.

Contents

Warnings - Instructions	6-12
First Trip Checklist	13
How to Check Your Trailer	14-18
Routine Maintenance Checklist	19
General Trailer Maintenance	20-21
Electrical Information	22
Loading Information	23
Warnings	24-26
Maintenance Record	28
Contact Information	29

Warnings - Instructions

Check your Haulmark trailer for the warning and instruction labels on the following pages. Many of those listed are mandated by the U. S. government and others will help you in the safe operation of your trailer. The following information is provided in the event that any of the labels are missing.

Federal I.D. plate mounted on side wall of trailer

MANUFACTURED BY / FABRIQUE PAR:		DATE:	
Haulmark Ind., Inc.			
P.O. Box 281 Bristol IN 46507-0281 (219) 825-5887			
GVWR/PNEU	KG	(LB)	
GVWR/PNEU	KG	(LB)	TIRÉS/PNEU
FRONT/ AVANT	KG (LB)		RIMS/AMTE
INTERM/ INTERM	KG (LB)		COLD INFL. PRESS./PRESS. DE GONFL. A FROID
REAR/ ARRIÈRE	KG (LB)		KPA SINGLE DUAL PSI/LPC <input type="checkbox"/> <input type="checkbox"/>
			KPA SINGLE DUAL PSI/LPC <input type="checkbox"/> <input type="checkbox"/>
			KPA SINGLE DUAL PSI/LPC <input type="checkbox"/> <input type="checkbox"/>
THIS VEHICLE CONFORMS TO ALL APPLICABLE U.S. FEDERAL MOTOR VEHICLE SAFETY STANDARDS IN EFFECT ON THE DATE OF MANUFACTURE SHOWN ABOVE. THIS VEHICLE CONFORMS TO ALL APPLICABLE STANDARDS PRESCRIBED UNDER THE CANADIAN MOTOR VEHICLE SAFETY REGULATIONS IN EFFECT ON THE DATE OF MANUFACTURE. - CE VEHICULE EST CONFORME A TOUTES LES NORMES QUI LUI SONT APPLICABLES EN VERTU DU REGLEMENT SUR LA SECURITE DES VEHICULES AUTOMOBILES DU CANADA EN VIGUEUR A LA DATE DE SA FABRICATION.			
V.I.N./N.I.N.:		TYPE/TYPE: TRAILER	HA2099

Located on tongue of trailer.

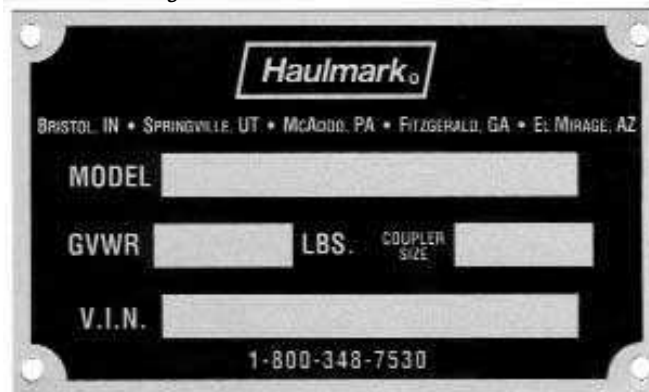

Warnings - Instructions

Located on side wall of trailer

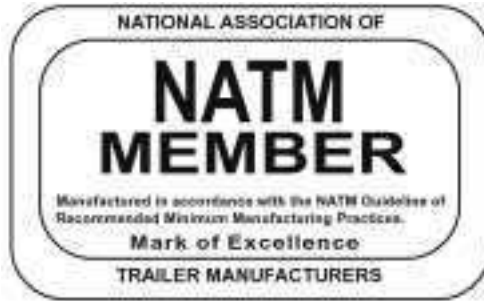

At transfer switch or junction box

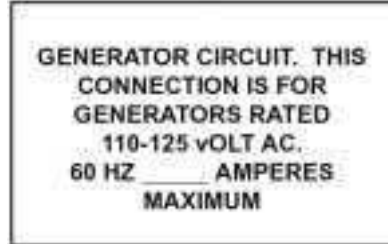

Located outside power supply



At transfer switch or junction box

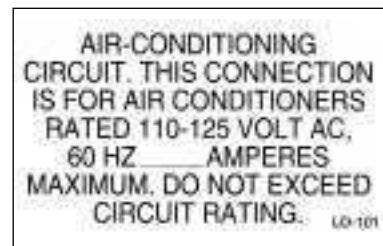

Located outside power supply



Located outside power supply

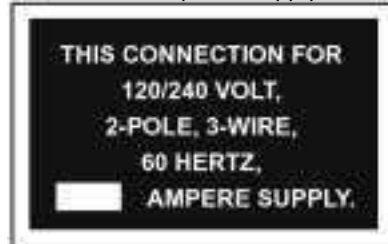

Located outside power supply



Located outside power supply

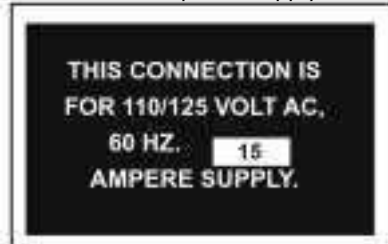

Warnings - Instructions

Located on battery box

THE SUPPLIED BATTERY IN YOUR KIT IS RECHARGEABLE AND MUST BE MAINTAINED FOR PROPER USE

FOR USE SINGLE, TANDEM AND TRI-AXLE TRAILERS

NOTICE:

- * CHECK CONDITION OF BATTERY AND CHARGE PRIOR TO TRIP.
- * CHARGE BATTERY PER ENCLOSED INSTRUCTIONS.
- * DO NOT EXCEED 1.2 AMPS MAXIMUM CHARGE.

Haulmark

INLINE CHARGER IS AVAILABLE THROUGH HAULMARK

HAZD19

Located on battery box

Each Trip:
Disconnect electrical plug.
Pull breakaway pin.
Bright light-battery o.k.
No light-charge battery.
Try to pull forward,
brakes should be on.
maximum charge-1.2 amps

Located above fuel filler door/cap on trailers with tank for diesel fuel

**DIESEL
FUEL ONLY**

Located on marine battery

BATTERY HOOKUP
(+) POSITIVE TO BLACK WIRE
(-) NEGATIVE TO WHITE WIRE

LD-101

Located above fuel filler door/cap on trailers with tank for gasoline

**GASOLINE
ONLY**

Located on breakaway switch

SAFETY BREAK-AWAY SWITCH WILL NOT OPERATE
unless connected to a power source equivalent to or greater than an automotive type 12 volt, 12 amp hour wet-cell battery.

LD-101

Located over side door

EXIT

LD-101

Warnings - Instructions

Located at LP tank on trailers with LP systems



Mounted on round-top caps



Located next to tongue tag at front side

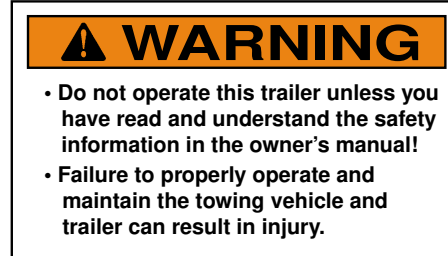

Located above stove



Located above stove

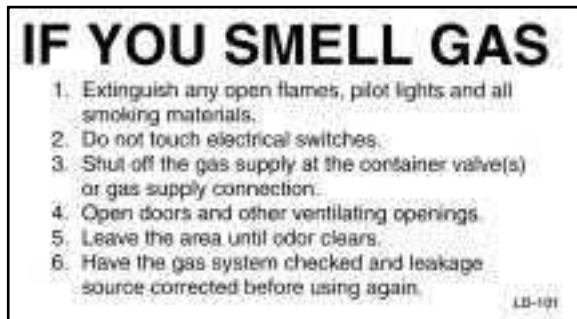

Warnings - Instructions

Located on walk-on roof platform



Roadside location inside trailer



Roadside location inside trailer indicating slippery ramp door



Located on all trailers with ladder racks and all Edge trailers



Located above doors with low openings



Warnings - Instructions

Located near all ramp doors



Located on or near generator



Located near awning door



Located on all ramp doors

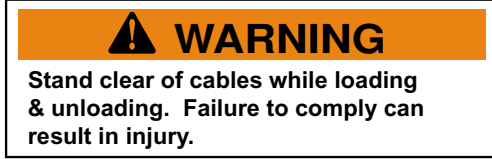

Located on or near slideout generator



*Located above water inlet on exterior,
 for trailers with city water connections*

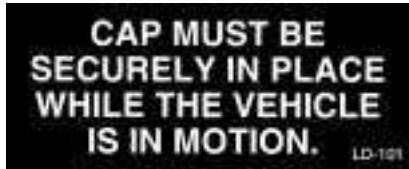

Located on roadside exterior



Located next to smoke detector

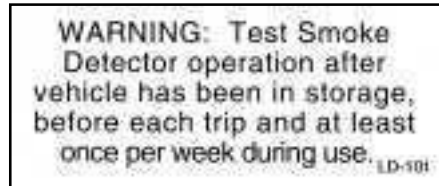

Located on roadside exterior



Warnings - Instructions

Located on luggage rack



Located on roof rack



Located on all roof and luggage racks

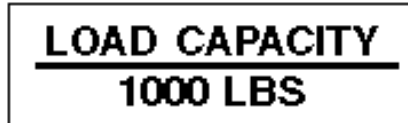

Located on roof rack



Located on electrical box cover of trailers with electrical connections



Located on interior sidewall of trailer

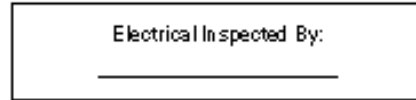

Located on swing-out lamp arm



Located inside closet door

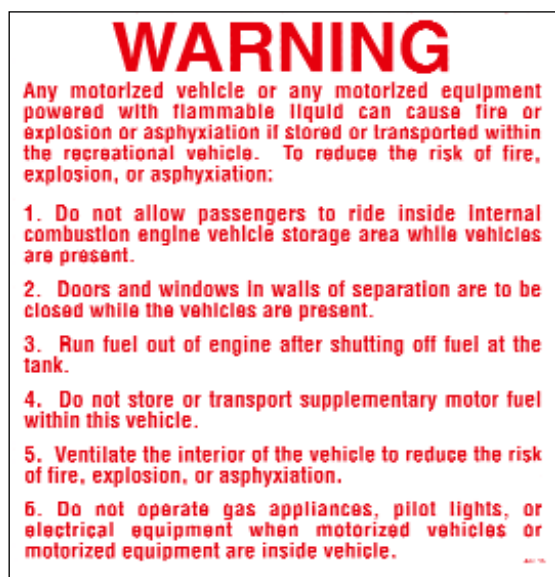

First Trip Checklist

Your Haulmark dealer has checked the following before you took delivery of your trailer, but these are things which you should recheck before towing your trailer for the first time. A description of how these parts work and how they should be properly checked is included on the following pages of this manual.

First Trip Checklist

Wheel Lugs*	<input checked="" type="checkbox"/>
Brakes/Brake Controllers	<input checked="" type="checkbox"/>
Bearing Lube & Tightness	<input checked="" type="checkbox"/>
Running Lights/Turn Signals	<input checked="" type="checkbox"/>
Safety Chains	<input checked="" type="checkbox"/>
Tire Condition & Tire Pressure	<input checked="" type="checkbox"/>
Hitch	<input checked="" type="checkbox"/>
Breakaway Battery Charge (for trailers with electric brakes) Test for Proper Operation	<input checked="" type="checkbox"/>
Doors, Windows, Roof Vents Closed & Locked	<input checked="" type="checkbox"/>
All Jacks are Up in Travel Position	<input checked="" type="checkbox"/>
Load Distribution & Security	<input checked="" type="checkbox"/>

*Also check at 10, 25, 50 miles and recheck every 3,000 miles or 3 months.

How to Check Your Trailer

Specifications

Axle system	2500# **	2500# **	2980#	7000# ***	7000#	10000#
Wheel Size	12"	13"	15"	14"	15#	15"
Bolt Pattern	5	5	5	5	5	6
Steel Wheel	50-75	50-75	90-120#	90-120#	90-120#	90-120#
Aluminum Wheel	n/a	n/a	90-120#	90-120#	90-120#	90-120#

All Wheels are Trailer Rated

Axle system	12000#	14000#	15000#	18000"	21000#	24000#
Wheel Size	16"	16"	15"	16"	16"	17.5"
Bolt Pattern	8	8	6	6	8	8
Steel Wheel	90-120#	90-120#	90-120#	90-120#	90-120#	190-210#
Aluminum Wheel	90-120#	n/a	90-120#	90-120#	n/a	190-210#

All Wheels are Trailer Rated

*Depending on Model
 ** Transport
 ***V-track/Snow-Tow

Wheel Bearings: Proper maintenance and inspection of wheel bearings is very important in the care of your trailer. Wheel lug nuts should be tightened with a torque wrench and checked every 10, 25 and 50 miles. Recheck them every 3,000 miles or 3 months thereafter. Please refer to the chart above for the proper torque of your trailer. You must also check the lube and tightness of bearings. This should be done on the first trip and then every 12, 000 miles or 12 months. Refer to the Dexter Axle owner's manual for complete instructions. Balancing is recommended.

Wheels: Check wheels for shape retention. If wheel is not round, this may be due to the lug nuts being loose or too tight. **Be careful to avoid chuck holes, curbs and other hazards in the road. Periodically checking your tires can help you avoid problems. Replace any wheel that is bent.

Brakes: Haulmark trailers are equipped with several types of brake options. Repair and service information for each available type of brake can be found in the Dexter Service Manual. Please follow all Dexter instructions concerning brakes to be eligible for

How to Check Your Trailer



WARNING

An improperly coupled trailer can result in death or serious injury.

Do not move the trailer until:

- The coupler is secured and locked to hitch;
- The safety chains are secured to the tow vehicle; and
- The trailer jack(s) are fully retracted.

Do not tow the trailer on the road until:

- Tires and wheels are checked;
- The trailer brakes re checked;
- The breakaway switch is connected to the tow vehicle;
- The load is secured to the trailer; and
- The trailer lights are connected and checked.



WARNING

Never crawl underneath your trailer when coupling or changing a tire! You risk severe injury or death.

Be sure that breakaway device is connected and working before use.

warranty provisions. Brakes on new trailers may tend to "pull" or pulsate. Don't worry, this is normal. To alleviate the situation, pull your trailer a short distance with the brakes slightly engaged.

Tire Pressure: The proper air pressure for your tires is printed on the tire. Air pressure should be checked while tires are cold. Be sure that you do not raise or lower pressure to meet your load. Excessive wear and tire failure will result if recommended pressure is not met.

Breakaway Battery: Before each trip, be sure to check and test the battery and break for proper charge and operation. Disconnect the electrical plug and pull breakaway pin. Light will indicate charge of battery. Maximum charge for the battery should not exceed 1.2 AMPS. **Breakaway cable must be connected to the tow vehicle; NOT to any part of the hitch or chains.**

Safety Chains: Be sure to always cross your safety chains when hooking to your trailer. Crossing your safety chains will make stop-

**Check lights and brakes before every trip!

How to Check Your Trailer



WARNING

Proper selection and condition of the coupler and hitch are essential to safely towing your trailer. A loss of coupling may result in death or serious injury.

- Be sure the hitch load rating is equal to or greater than the load rating of the coupler.
- Be sure the hitch size matches the coupler size
- Observe the hitch for wear, corrosion and cracks before coupling. Replace worn, corroded or cracked hitch components before coupling the trailer to the tow vehicle.
- Be sure the hitch components are tight before coupling the trailer to the tow vehicle.



Safety chains must be crossed while you are towing the trailer! Inspect for wear or damage!



The safety pin must always be used on a coupler hitch when towing.



25000# Hitch

◀ *Safety Pin must be in the closed position when towing.*

Hitch is shown in the open position for coupling only. ▶



ping your trailer easier if the trailer hitch is dragging on the ground. **(Crossing your safety chains is required by law.)** Chains which are too long should be shortened and chains which have been stressed should be replaced.

Stabilizer Jacks: Always remember to block tires before using stabilizer jacks! Not blocking tires may result in the failure of your stabilizer jacks, property damage and personal injury.

How to Check Your Trailer



WARNING

Recommended Care for New Hitches:

1. Always keep hitch ball greased.
2. Replace worn hitch balls or locking lugs promptly.
3. Replace worn hitch pins and 5th wheel jaws promptly.
4. When in doubt, consult either tow vehicle manufacturer, vehicle owner's manual, dealership or hitch specialist.



Adjustable height king pin 5th wheel hitch



Adjustable ball coupler gooseneck hitch. Make sure latch is closed before towing.



Gooseneck hitch shown with safety chains and breakaway cable affixed to the tow vehicle. Always tow with the safety pin locked as shown. (5th wheel must have safety chains attached to vehicle also!)

The Hitch: It is your responsibility to correctly match your tow vehicle to your trailer. To do this, here are some steps to follow:

1. Match the GVWR of your trailer to the maximum trailer weight allowed for your tow vehicle.
2. Match the hitch weight carrying capacity of your tow vehicle with the loaded tongue weight of your trailer.
3. Match the size of the brake controller to the number of braking wheels on your trailer.
4. Match the electrical wiring of your tow vehicle to the wiring on your trailer. Be sure to check that your tow vehicle has a ground wire running from the receptacle to the frame.
5. Match the ball size to the coupler size.

****If you have any questions regarding your hitch, call a specialist!**

Gooseneck/5th Wheel Trailers:

Your trailer will be equipped with one of the hitches shown above. Be sure that the king pin or ball coupler on tow vehicle is rated for at least as much weight as the GVWR on your trailer. The adjustable height king pin requires an S.A.E. 2" 5th wheel hitch and the adjustable height ball coupler hitch requires a 2 5/16" hitch ball. (Some special order goosenecks are equipped with a 3" gooseneck ball.) **Always check your gooseneck ball or fifth wheel for cracks or wear before towing!**

How to Check Your Trailer

Hitch Balls: Hitch balls come in a variety of diameters and capacities, the GVWR is always stamped on the ball. Depending on the GVWR, your trailer is equipped with either a 2" or 2 5/16" ball. Be sure that the ball matches or exceeds the GVWR of your trailer and the diameter of the ball matches the coupler on the trailer!

Never tow your trailer with an improper size ball!

Walk-on Roof Platform: If you have a trailer with a walk-on roof platform, you must make sure that the safety locks are securely in place while in use and when it is not in use. Please refer to the pictures at right to see the proper locked positions.



42" railing locked in "down" position.



42" railing locked in "up" position.

Routine Maintenance Checklist

Routine maintenance must be performed on your trailer to ensure its safe and economical use. On the following pages you will find some simple steps that you may find useful. If you have any questions regarding trailer maintenance, call your dealer or Haulmark.

Check	How	Every Trip	Every 3000 mi or 3 mo.	Every 6000 mi or 6 mo.
Tire Pressure	Inflate to Pressure Indicated on Tire	✓		
Wheel Lugs, Nuts & Bolts*	Tighten to Proper Torque Specifications	✓		
Coupler Ball or 5th Wheel & Pin	Check for Unusual Wear, Sufficient Lube and Lock Mechanism	✓		
Safety Chains & Hitch Ball	Check for Unusual Wear on Chain Links and Hitch Ball	✓		
Coupler	Check Safety Pin for Proper Fastening	✓		
Brakes	Check General Operation and Proper Adjustment	✓		
Breakaway Battery	Check Charge Light by Pulling Switch Pin	✓		
Doors, Windows & Vents	Close and Lock all Doors, Windows and Vents before Travel	✓		
Welds	Check Welds for Cracking or Separations			✓
Hinges	Check for Proper Operation, Lubricate with Light Oil		✓	
D-ring Tie Downs, E-Track	Check for Fractures, Loose Anchor System		✓	
	Check for Proper Operation and Replace Burned Bulbs	✓		
Load Distribution	Check and Secure Load Distribution	✓		
	Check Door Latches	✓		

**Check first trip and after 10, 25, 50 miles. Then check after every 3,000 miles or 3 months.*

***Please refer to corresponding manufacturer's owner's manual.*

General Trailer Maintenance

Roof: Inspect your roof at least once a year. If there is any loose material, clean and follow with a roof coating. (This coating is available through a recreational vehicle dealer.) If you have any questions about your roof, contact Haulmark.

Frame: Normal road use will eventually chip away at the factory-protected underside of your trailer frame. Check the underside of your frame at least once a year and repair any chips with an automotive undercoating or matching paint. This protection can help prevent rust and deterioration of the trailer.

Floor: To protect your floor, promote long life and make cleaning easier, Haulmark recommends painting the floor with an oil-based enamel. This added protection will help with cleaning up spills and routine cleaning.

Exterior Skin: Your trailer should be treated with the same care as your car. To clean, use a mild soap and protect with an automotive-type wax.

Steel Edges: EXPOSED STEEL EDGES MAY BE SHARP TO TOUCH! Take extra precautions when touching exposed steel

edges. When cut, steel edges sometimes have burrs which can cause injury. Use a file to get rid of burrs or cut them off with a wire cutter.

Aluminum Rims: Your aluminum rims are clear-coated so they may protect the finish and give you ease in cleaning. Be sure to use a gentle cleaning agent for your rims. Never use any cleaner which contains a lye or is acid-based. These cleaners will damage the finish of your rims.

Screws: If you should need to replace exterior screws, use a #2 square drive bit. These can be found at any hardware store.

Welds: We recommend that you check all welds every 6 months or 6,000 miles for cracks or fractures. Also check steel surfaces for cracking. If you detect any cracking or fractures, contact your dealer or Haulmark immediately.

Brakes: Your trailer brakes must be inspected and serviced at yearly intervals, or more often as use and performance requires. Consult your Dexter Maintenance Service Manual for more information.



WARNING

A spring and cable counterbalance can inflict serious injury if it breaks, or if incorrectly adjusted. Always stand clear of the door when opening.

Inspect the cable and cable ends for wear each time the door is operated.

Do no attempt to service the counterbalance. Take the trailer to your dealer for service.

General Trailer Maintenance



WARNING

Gas springs on vending doors lose their lifting capability with age and cold weather; and can cause the door to fall, resulting in injury.

Always hold the door open until the prop rods are in place.

Always use prop rods to hold vending or accessory doors open.

Be prepared to hold the weight of the door when removing the prop rod.

Ramp Door: Ramp door hinges must be lubricated with Lithium grease. And the ramp door extension must be lubricated periodically.

Tires: Improper tire pressure can result in a blowout and loss of control, which can lead to death or serious injury. Be sure tires are inflated to pressure indicated on side wall before towing trailer. If a tire has a

bald spot, bulge, cuts is showing any cords, or is cracked, replace the tire before towing.

Huck Bolts: May be at various locations on the sub-frame. Huck bolts are not user serviceable. If you detect a loose huck bolt fastener, do not tow the trailer. Call your dealer for instructions.

Electrical System

Wiring: Your tow vehicle must have the correct plug at the rear and must be connected to the correct tow vehicle circuits for the vehicle to correctly tow the trailer. Trailers not equipped with brakes will have a 4-way flat plug and all other trailers will have a larger 7-way round plug.

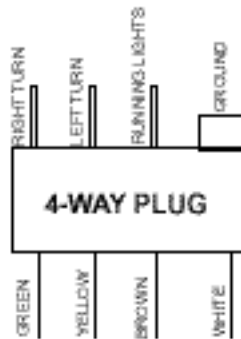

Receipt

WHITE	1	GROUND
BLUE	2	BRAKES
GREEN	3	RUNNING LIGHTS
BLACK	4	HOT LINE
RED	5	LEFT TURN SIG
BROWN	6	RIGHT TURN SIG
YELLOW	7	AUXILIARY

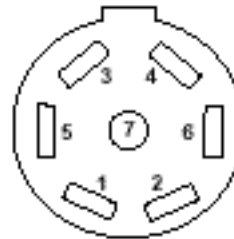

**7-WAY PLUG
for tow vehicle**

It is very important that you have a ground wire running from the plug to the frame of your tow vehicle. Hitches, safety chains and couplers are not adequate grounds for your trailer. If an auxiliary battery is added to your trailer, there must be a fuse installed between the battery and the trailer. If you have any questions regarding the wiring of either your tow vehicle or your trailer, contact either your dealer or Haulmark.

Loading Your Haulmark

Proper loading of your haulmark trailer is imperative! Uneven loading and insufficient hitch weight of your trailer can cause your trailer to be unstable and result in serious bodily injury. Be sure to follow these instructions when loading your trailer.

**Be sure to check the towing capacity of your tow vehicle before towing your trailer.

**Light-weight cargo trailers are not designed to be pulled by trucks larger than a 1-ton capacity.

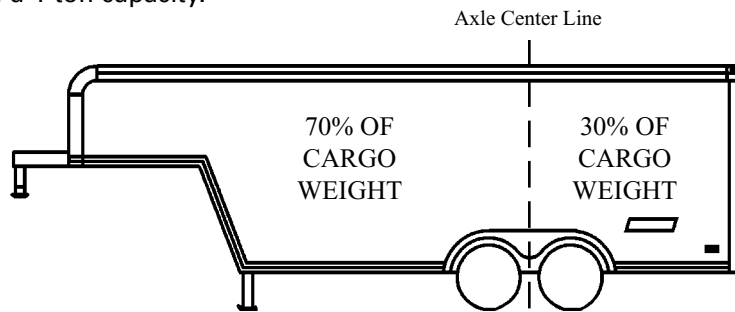

WARNING

Damaged or loose "D"-rings can break, allowing cargo to become loose inside the trailer. Loose cargo can shift the center of gravity, and result in loss of control of the trailer.

Inspect "D"-rings, and test them for looseness before loading cargo.

Do not use a damaged or loose "D"-ring to secure cargo.

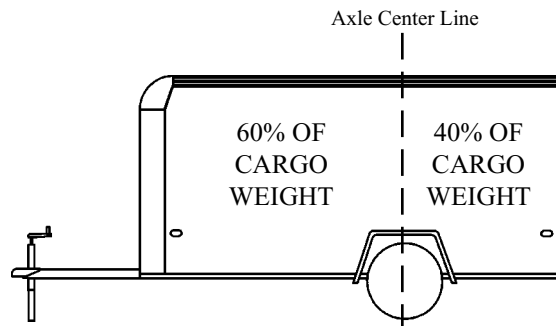

**Improper use of weight distributing hitch can cause damage to your trailer. Read all hitch instructions before use.

**You must secure your cargo so that it does not shift while the trailer is being towed.

Warnings - Transporting



WARNING

Do not transport people inside the trailer, even if it has living quarters. The transport of people puts their lives at risk and may be illegal.



WARNING

Do not transport flammable explosive, poisonous or other dangerous materials in your trailer.

Exceptions:

- Fuel in the tanks of vehicles that are being towed
- Fuel stored in proper containers used in trailer living quarters for cooking
- Fuel stored in the tank of an on-board generator

Accessories - Warnings

Generator:

If your trailer is equipped with a gasoline or diesel generator, you must have and follow the generator manufacturer's instructions. You must also have one or more carbon monoxide detectors in the trailer's accommodation spaces.

Carbon Monoxide is an odorless gas that can cause death. Be certain exhaust from a running generator does not accumulate in or around your trailer, by situations such as:

- **Being drawn in by fans or ventilators operated in a trailer.**
- **Prevailing wind**
- **Being trapped between your trailer and other trailers, vehicles or buildings;**
- **Being trapped between your trailer and, or in a snow bank, or other nearby objects**



WARNING

Accumulation of hazardous fumes can cause death or serious injury. Do not block access to ventilation ports.

Warnings



WARNING

Operating gasoline and diesel generators can lead to death or serious injury by:

- Carbon monoxide
- Fire and Explosion
- Electrocutation

Have a working carbon monoxide detector in the accommodation spaces before operating a generator.

Do not refuel a running generator or refuel near ignition sources.



WARNING

Shore power poses a risk of death due to electrocution or fire

Always use an electrical cord specifically designed for shore power connection. Never use an ordinary extension cord.

Always connect the electrical cord to a grounded source of shore power.

Do not remove the "third prong" from the shore power plug.

Connect only to source of proper voltage.

Make certain polarity is correct.

Do not overload electrical circuits.

Always replace fuses or circuit breakers with correct rating.



DANGER

You can die or be brain damaged by Carbon Monoxide.

Make certain the exhaust from LP appliances is directed to the outdoors.

Have a working carbon monoxide detector in the accommodation spaces of your trailer before operating any LP gas appliance.

Do not operate portable grills or stoves inside the trailer.



WARNING

Risk of fire or explosion

Never use a flame, heat lamp or hair dryer to thaw an LP gas regulator. Use an incandescent light bulb.

Do not remove the regulator cover or attempt to service the LP gas regulator.

Warnings



WARNING

Risk of fire or explosion

If LP gas is detected (by smell or by the LP gas detector):

- Do not touch electrical switches
- Extinguish flames and pilot lights
- Open doors for ventilation
- Shut off LP gas supply at the LP tank
- Leave the area until odor clears.

Correct the source of LP gas leakage before using LP appliances.

Do not use a flame to locate the source of an LP gas leak.



WARNING

Risk of death due to fire or explosion.

Only connect an LP gas system to supply of LP gas, NOT natural gas.

Do not store LP gas tanks inside the trailer.

Only fill an LP gas tank 80% full

Only fill the tank with LP gas (butane or propane).

Overfilled tanks can release gas and cause an explosion.



NOTICE

Use butane only when the temperature is above freezing (32 degrees F)

Propane gas will operate at temperatures as low as minus 44 degrees Fahrenheit (-44F).

Contact Information

Haulmark Industries, Inc.

(corporate offices)
P. O. Box 281
14054 C. R. 4
Bristol, IN 46507
1-800-348-7530
Phone: 219-825-5867
Fax: 219-825-9816

Haulmark Industries of Pennsylvania, Inc.

P. O. Box 8
Kline Road
McAdoo, PA 18237
1-800-800-1664
Phone: 717-929-3761
Fax: 717-929-2141

Haulmark of Georgia, Inc.

P. O. Box 1286
122 Glen Bass Rd.
Fitzgerald, GA 31750
1-800-270-8421
Phone: 912-423-2202
Fax: 912-423-2330

Haulmark Industries, Inc.

Special Products
P. O. Box 281
19224 C. R. 8
Bristol, IN 46507
1-800-645-2374
Phone: 219-848-4448
Fax: 219-848-4074

Haulmark Industries of Utah, Inc.

1650 North and 1350 West
Springville, UT 84663
1-800-828-4285
Phone: 801-377-8503
Fax: 801-491-7033

Haulmark Industries of Arizona, Inc.

8320 N. El Mirage Rd.
El Mirage, AZ 85335
1-877-335-4620
Phone: 623-535-7700
Fax: 623-535-7702

**Look for us on the Internet at: www.haulmark.com
Our e-mail address is: sales@haulmark.com**

**FOR THE NAME OF THE NEAREST SERVICING
DEALER OR MANUFACTURING FACILITY CALL**

1-800-348-7530