

Corcraft
PRODUCTS

SPECTRA

CHROME FRAME

SEATING GROUP



OFFICE/ CONFERENCE/

Seating



NYS
DEPARTMENT
OF
CORRECTIONAL
SERVICES

SPECTRA

SWIVEL/TILT CHAIRS

SEATING GROUP

Contemporary styling complemented by swivel/ tilt controls are important features found in the Spectra Executive and Deluxe Executive group. Additional options include pneumatic height adjustment paddles or heavy-duty swivel/ tilt units.

Corcraft
PRODUCTS

For maximum comfort and adjustability, choose Spectra for your office or conference seating.

FEATURES

Frame

Chromed tubular 16 gauge steel, 1" diameter .

Seat

Polyether foam on plycurve, upholstered.

Back

Polyether foam on plycurve, upholstered.

Arm

Padded armrest, upholstered.

Swivel Base

- Cast aluminum, polished chrome plated.
- 5 star, 25" diameter base on swivel chairs.

Casters

- 2½" plastic polished chrome hooded, twin soft urethane wheels.



**** Complete the code indicating your Corcraft fabric covering choice by including the data in the spaces provided to the right of the item code.

Note: Cannot be made in vinyl or with Crypton fabrics.

F54-105300-3630

Corcraft is your NYS preferred source vendor — place your order today!

SEATING ADJUSTMENT CONTROLS

- Standard duty swivel tilt chair control with adjustable tilt tension and overall height.
- Optional pneumatic height adjustment available.
- Heavy-duty Spectra Executive Swivel/Tilt units feature reinforced chair controls and heavier gauge collar components.

(1) Seat Height Adjustment

- Raise** – Turn Retaining Collar Clockwise
- Lower** – Turn Retaining Collar Counterclockwise

(2) Tilt Tension Adjustment

- Raise Tension** – Turn Control Knob Clockwise
- Lower or Loosen Tension** – Turn Control Knob Counterclockwise

(3) Pneumatic Seat Height Adjustment Paddle

Raise body weight off seat, pull paddle up to raise seat height. To lower seat height, raise paddle up until seat lowers to desired height.

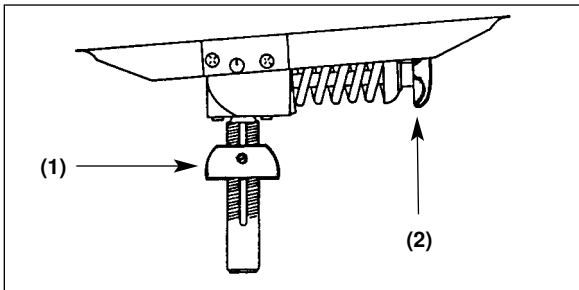

F54-105300, F54-105400, F54-105000 Side View

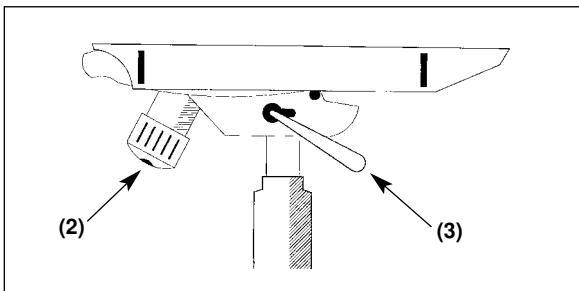

With pump: F54-1053WP, F54-1050WP

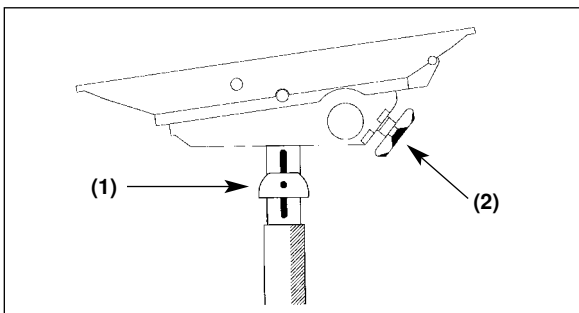

Heavy duty: F54-1053HD, F54-1054HD, F54-1050HD

DELUXE EXECUTIVE SWIVEL/TILT



Deluxe Executive Swivel/Tilt w/Arms†

F54-105300-_*_*_*_*_*
25W X 26D X 42H
Weight 35 lb

Deluxe Executive Swivel/Tilt w/Arms, Heavy-Duty

F54-1053HD-_*_*_*_*_*
25W X 26D X 42H
Weight 35 lb

Deluxe Executive Swivel/Tilt w/Pump/Arms

F54-1053WP-_*_*_*_*_*
25W X 26D X 42H
Weight 35 lb

EXECUTIVE SWIVEL/TILT



Executive Swivel/Tilt Armless†

F54-105400-_*_*_*_*_*
25W X 26D X 32H
Weight 32 lb

Executive Swivel/Tilt Armless, Heavy-Duty

F54-1054HD-_*_*_*_*_*
25W X 26D X 32H
Weight 32 lb

Executive Swivel/Tilt w/Arms†



F54-105000-_*_*_*_*_*
25W X 26D X 32H
Weight 33.5 lb

Executive Swivel/Tilt w/Arms, Heavy-Duty

F54-1050HD-_*_*_*_*_*
25W X 26D X 32H
Weight 33.5 lb

Executive Swivel/Tilt w/Pump/Arms

F54-1050WP-_*_*_*_*_*
25W X 26D X 32H
Weight 33.5 lb

† Shown on cover

SPECTRA

CONFERENCE AND SIDE CHAIR

SEATING GROUP



F54-1052SB-3254

The Spectra conference and side chairs offer good looks and contemporary flair with a chromed tubular steel frame and sled base construction. The upholstered seat, back and arms are available in a wide choice of fabrics and colors, to coordinate with your design scheme.



Spectra conference and side chairs are designed for carpeted floor applications only.

F54-1051SB-3254

Conference Chair

F54-1051SB- * * * * *
25W X 26D X 33H
Weight 27 lb

Side Chair

F54-1052SB- * * * * *
22½W X 26D X 33H
Weight 22 lb

**** Complete the code indicating your Corcraft fabric covering choice by including the data in the spaces provided to the right of the item code.

Note: Cannot be made in vinyl or with Crypton fabrics.

Corcraft is your NYS preferred source vendor — place your order today!

All Corcraft customers can get assistance from a Corcraft Sales Representative. They provide detailed information on the more than 300 Corcraft products and can help in selecting the best solution and in placing orders. If you have not been contacted by Corcraft, please call our Sales Unit list to the right. To place an order directly to our headquarters, FAX or mail your purchase order using the contact information at the right. *If you FAX your purchase order, please do not mail a duplicate.*

Corcraft
PRODUCTS

**NYS DEPARTMENT OF CORRECTIONAL SERVICES
DIVISION OF INDUSTRIES**

550 Broadway
Albany, New York 12204-2802

Order Services Mail to above address
Order Services FAX 800-898-5895 (In NYS) or 518-436-6007
Sales Unit Voice 800-436-6321 ext. 200 (In NYS) or
518-436-6321 ext. 200
Web <http://www.corcraft.org/>

Corcraft accepts the American Express® Corporate Purchasing Card. 