



CITY OF
West Linn

Shane Boyle, Information Technology Manager
Invites Qualified Candidates to Respond to a
Council Chamber Audio/Visual Technology Modernization
Request for Quotation

Date Issued: Wednesday, April 01 2015
Date Due: Wednesday, April 15, 2015
Time Due: 4:00PM, Pacific Time Zone

SUBMIT QUOTATIONS TO:

Shane Boyle
Information Technology Manager
Information Technology Department
Sboyle@westlinnoregon.gov
City of West Linn City Hall
22500 Salamo Road,
West Linn, OR 97068

Request for Quotation

Council Chamber Audio/Visual Technology Modernization

City of West Linn invites qualified firms or individuals to submit quotations to provide a modernization of the city's council chamber Audio/Visual infrastructure. The City of West Linn council chamber technology environment requires improved reliability and effortless usability. City of West Linn is expecting to receive quotations for hardware, software, and installation service from qualified organizations based upon the scope of work contained in this request for quotation. The intent is to select one firm to provide all services.

Quotations, in written or digital format, will be received by Shane Boyle, Information Technology Manager, City of West Linn, 22500 Salamo Road, West Linn, OR 97068, until Wednesday, April 15, 2015 at 4:00 P.M. pacific. Late Quotations will be retained but not considered for award.

The complete Request for Quotation is on file with and may be obtained from Shane Boyle, Information Technology Department, 22500 Salamo Road, West Linn, OR 97068, 503-722-5506, sboyle@westlinnoregon.gov. Information about the request for quotation can also be found at the City of West Linn website: <http://www.westlinnoregon.gov>

Published Wednesday, April 01, 2015

SECTION I BACKGROUND AND SCOPE OF WORK

1 Background and Scope of Work

1.1 Description of the Scope of Work

The City of West Linn invites qualified individuals or firms to submit Quotations to provide the services described in this Request for Quotation (RFQ).

1.2 Background Information

City of West Linn is seeking an experienced and qualified individual or organization to procure, program and install new audio/visual equipment in the City's council chamber located at city hall. The installation of the new equipment will require removal of most existing equipment. Specific existing equipment will be retained and required to be integrated into the new technology platform. The quotation for services will need to fit the City of West Linn supplied design requirements contained within this request for quotation. Deviations from the specified requirements will not be acceptable and may disqualify a submission.

1.3 Statement of the Bidders Role and Desired Qualifications

The City is seeking an individual or firm to provide a fixed fee bid for the procurement of hardware/software/labor to complete the council chamber audio/visual technology modernization. Change orders will be allowed for the selected individual or firm but will not be allowed to exceed 5% of fixed fee bid value.

The selected individual or firm must have following qualifications to be deemed a subject matter expert and qualify for bid consideration.

- Vendor sponsored certification in hardware/Software being quoted in submitted bid.
- Five years as a going concern with minimum two years in Audio/Visual technology project implementation.
- Provide availability for ongoing labor warranty support and non-warranty support.

1.4 Project Goals

1.4.1 Hardware (Procurement)

- Bid Tier 1 digital audio/visual hardware (Crestron/Extron).
- Bid 3 year next business day support warranty.
- Bid all special use connectors, cables, and mounting sundries.
- Bid hardware with minimum 5 years of vendor supportability.

1.4.2 Software (Programming)

- Bid software programming for all supplied hardware.
- Bid configuration support for city supplied tablets, computers, and miscellaneous.

- Bid supplemental software required that is not supplied by hardware manufactures.

1.4.3 Labor (Implementation)

- Procurement and delivery of all hardware and software specified
- Project management planning and implementation support
- Installation of hardware/software to specification
- Configuration of hardware/software to specification
- Installation of cabling to support hardware/software
- Other labor required for project success

1.5 Definition of Project Success

The selected vendor will implement all hardware/software/configuration within the City of West Linn's specifications within the agreed upon timelines. Successful integration with the municipal court system and public broadcasting is required. A maximum of 5% over specified bid price in change orders may be authorized.

1.6 Significant Issues

City of West Linn is a year round government body downtime is limited to very specific windows. Equipment implementation will require adherence to strict time windows. The project involves overall architectural changes which requires hardware configuration to be correct the first time. The labeling, documenting and testing of equipment configuration is required prior to live deployment.

The council chamber is a multi-use room requiring the integration of our existing municipal court system and our MACC/TVCTV public broadcasting systems. Communication with these vendors and systems will be required to facilitate a successful project.

1.7 Time Period for Completion of the Project

- April 20, 2015 RFQ award & contract execution completed.
- April 30, 2015 – Project planning and equipment procurement completed.
- May 21, 2015 – Project hardware/software and labor installation completed and tested.
- May 22, 2015 – Staff system use and administrative training.
- May 29, 2015 – Project close meeting.

SECTION II QUOTATION PROCESS

2 Quotation Process

2.1 Schedule of RFQ Events

Event	Event Date
RFQ Released	April 01, 2015
RFQ Response Due	April 15, 2015
RFQ Vendor Interviews*	April 16, 2015
RFQ Award Announcement	April 20, 2015
Project Install Started **	April 30, 2015
Project Install Completed**	May 21, 2015
Project Close Meeting**	May 29, 2015

* The need for vendor interviews will be determined by the City.

** Dates are approximate and City of West Linn reserves the absolute right to approve vendor requested changes to established dates.

2.2 Pre-Quotation Conference

Not required for this project. Vendors may request and schedule a facility walk through during the RFQ response development period April 1, 2015 through April 15, 2015.

2.3 Quotation Due Date

One (1) copy of the quotation must be delivered to no later than Wednesday, April 15, 2015 by 4:00 P.M. Pacific time. Late Quotations will be retained but not considered for award.

City of West Linn
Information Technology Department
22500 Salamo Road
West Linn, OR 97068

Quotations must be clearly addressed and marked with the RFP number and title. Digital submissions preferred. Quotations may be mailed to the City, but must be received by the information technology manager no later than the above stated date and time. It is the responsibility of the proposer to ensure the quotation is received in a timely manner. Hand delivered quotations will be received at the front desk in the main lobby of City of West Linn City Hall.

2.4 Quotation Handling and Public Record

The City will not disclose publicly or share vendor quotations with non-City of West Linn staff.

2.5 Solicitation Protest

A person may protest or request a change of a solicitation provision, evaluation criteria, scope of work, specification or contract term no later than Fourteen (14) calendar days prior to the Quotation due date. No protest of the selection of an individual or firm award of a contract because of a solicitation provision, evaluation criteria, and scope of work, specification or contract term will be considered after such time. The protest or request for change shall include the reason for the protest or change, any proposed language, and why the proposed language would benefit the City. The City shall consider the protest or request for change and may reject the protest or request for change, issue an addendum or cancel the RFQ. The protest must be submitted to the Information Technology Department at the following address:

Shane Boyle
Information Technology Manager
City of West Linn City Hall
22500 Salamo Road
West Linn, OR 97068
503-722-5506
Sboyle@westlinnoregon.gov

2.6 Official Contacts

Questions regarding the scope of services, site visits and other facilitations must be directed to the Information Technology Manager:

Shane Boyle
Information Technology Manager
City of West Linn City Hall
22500 Salamo Road
West Linn, OR 97068
503-722-5506
Sboyle@westlinnoregon.gov

SECTION III QUOTATION FORM AND CONTENT

3 Quotation Form and Content

3.1 General Information

Quotations shall be prepared simply and economically, providing a straightforward, concise description of the proposer's capabilities to satisfy the requirements of this RFQ. Emphasis should be on completeness and clarity of content and cost effectiveness of the Quotation.

Provide one easily reproducible original of the Quotation. Quotations shall be easily recyclable; plastic and wire bindings are discouraged. The Quotation shall not exceed Twelve (12) pages in length; consecutively number all pages of the Quotation. Organize the Quotation in accordance with RFQ Section 3.2 through 3.8.

3.2 Letter of Transmittal

All Quotations must include a cover letter addressed to the City's Information Technology Manager and signed by a duly constituted official legally authorized to bind the proposer to its Quotation. The cover letter may summarize the key provisions of the Quotation. The cover letter must include the name, address, email address and telephone number of the proposer and the name, title, address, email address and telephone number, of the person authorized to represent the proposer and to whom the City should direct correspondence.

3.3 Project Understanding

The proposer shall include a detailed statement to demonstrate its understanding of the project, including but not limited to:

- The City's goals in pursuing the project.
- The role of the proposer.
- Key project milestones, which are most important, and the ramifications of missing milestones.
- The key deliverables required by the project.

3.4 Qualifications

Quotations shall demonstrate the qualifications and experience of the personnel who will work directly with the City rather than describing the general experience and qualifications of the firm. The City will not consider promotional literature of a general nature. The focus should be on recent and local project experience within the last two years that is relevant to the scope of work outlined in this RFQ. Include the following information:

3.4.1 Qualifications of the Firm

- Describe the firm’s capabilities and experience.
- List recent experience working with similar projects.
- List recent experience working with government clients
- Describe how the firm is legally qualified in the State of Oregon to perform the work requested.

3.4.2 Project Manager Qualifications

- The project manager is the person who will be assigned by the proposer to provide day-to-day management of this project.
- List the qualifications of the project manager who will work on this project. Include a description of the relevant education and training, certificates and licenses, professional background, and years of experience with work relevant to the scope of this RFQ.
- Describe the experience of the project manager, particularly similar projects with similar entities. Identify the project manager’s specific role in relevant projects; do not include projects where the project manager had a minor or no active role. The City will only consider projects that include a client contact name and phone number.
- If submitting a resume, only include project experience relevant to the scope of work outlined in this RFQ.

3.4.3 Key Technical Personnel Qualifications

- Provide information about the qualifications and experience of key personnel. (See Project Manager Qualifications)
- If submitting a resume, only include project experience relevant to the scope of work outlined in this RFQ.

3.4.4 Subcontractor Qualification

If a subcontractor will be used in this project:

- Provide information about the qualifications and experience of any subcontractor(s). (See Project Manager Qualifications)
- Describe the experience of the project manager and key personnel working with the subcontractor(s).

3.5 Project Approach and Schedule

The proposer shall include a detailed statement of its approach to the project and schedule. Include the following information.

- An overview explanation of proposer’s approach to the work, the techniques the proposer expects to use, and the use of key personnel. This should include an explanation of any modifications of the work items and scope of work presented in this RFQ.
- Describe how proposer would use City personnel, if at all, to assist during the project and indicate the approximate time requirement.
- Describe the projected workload of the project manager, key personnel and subcontractors and demonstrate their availability to timely provide the services requested in this RFQ.
- Describe your approach to the overall management and integration of all activities required by the scope of work, including quality assurance, responsibility, and cost control.
- Outline a work plan and related time schedule for each significant segment of the work. This may include a GANT or PERT chart.
- Include an estimate the amount of hours each staff will spend per task substantially in the following format:

Tasks	1- Title	2 - Title	3 - Title	Hours
	1			1
		1		1
			1	1
	1	1	1	3
TOTAL	2	2	2	6

- Provide any additional information about proposer’s project approach that would be beneficial to the selection committee.

3.6 Additional Information

Provide any other information that the proposer feels applicable to the evaluation of the Quotation or of their qualification for accomplishing the project. Use this section to address those aspects of your services that distinguish your firm from other firms. Additional information shall be considered when evaluating the proposer’s Project Approach and Schedule.

Proposers are encouraged to improve upon the tasks, work items, or other elements described in this RFQ. However, prior to basing a Quotation on those improvements, proposers should check with the City’s Information Technology Manager to ensure that the City views the changes as desirable improvements.

If there is no additional information to present, state, “There is no additional information we wish to present.”

3.7 Cost Schedule

The proposer's cost schedule shall be submitted with the Quotation. All costs are to be contained in this section. For each project category (hardware, software, labor), include a cost and state a grand total for all project categories. This section shall also include payment terms required for services rendered.

The cost schedule shall include:

Proposer's fee for the requested work as follows:

- Using the amount of hours estimate from section 3.5, state the fee by phase, task, and total hours.
- Total hours by staff classification multiplied by the hourly billing rate.
- Cost and personnel should be clearly tied to the project specific tasks (including subcontractor personnel and costs).
- All out-of-pocket costs.
- Any other anticipated fees or costs.
- A fee for each phase of the project.
- Proposed or preferred schedule of billing dates and payment terms.
- The method used to charge for any special requests, Changes orders that broadening of the scope of the work beyond that described in this RFQ or mitigate a risk factor identified.

3.8 Certification Statement

All Quotations must contain a signed certification statement (See Section VII Forms & Requirements).

SECTION IV EVALUATION / SELECTION OF QUOTATIONS

4 Evaluation / Selection of Quotations

4.1 Clarifications

The City reserves the right to seek written clarification of each quotation submitted. The City also reserves the right to require other evidence of minimum qualifications, technical, managerial, financial, or other abilities prior to selection.

4.2 Evaluation Criteria

The City will make a selection based on the evaluation of the written quotations and interviews (if required). The City may elect to interview all proposers or only the highest ranked proposers. The City reserves the right to make a selection based only on the evaluation of the written quotations. Written quotations and interviews will be evaluated based on the following criteria:

- Project Understanding – 10 points
- Organization Qualifications – 30 points
- Project Management Approach– 30 points
- Cost Schedule - 30 points

Information gained during an interview if scheduled will be considered during the evaluation of the written quotation.

4.3 Method of Selection

A selection committee will evaluate each submitted written quotation and each interview, when applicable, to determine whose quotation is the most advantageous to the City based on the evaluation process and evaluation criteria outlined in this RFQ. The City will award the contract to the highest ranked responsive proposer.

4.4 Single or Multiple Contracts

One firm will be selected to provide all services.

4.5 Notice of Intent to Award

Upon completion of the evaluation process, the selection committee will advise all proposers as to if they were selected or not selected.

4.6 Selection Protest

Proposers who disagree with the City's selection decision may protest that decision. The judgment used in the scoring by individual evaluators is not grounds for appeal. No protest because of a solicitation provision, evaluation criteria, or scope of work, specification or contract term that could have been raised as a solicitation protest will be considered. The selection protest must be submitted in writing within five (5)

calendar days of the Notice of Intent to Award. The protest shall be submitted to the Information Technology Manager at the following address:

City of West Linn City Hall
Information Technology Department
22500 Salamo Road
West Linn, OR 97068

The selection protest must state all the relevant facts that establish that all higher ranked proposers were ineligible for selection. A written decision will be sent to the protester.

4.7 Agreement

The City reserves the right to negotiate a final contract that is in the best interest of the City.

The contract will define the extent of services to be rendered, method and amount of compensation. The contract will be negotiated with the number one ranked proposer for the project. If an agreement is not reached, negotiations will be terminated. Negotiations will then begin with the selection committee's second choice for the project.

When an agreement is reached, a contract for the work will be prepared and executed with City Manager approval.

The successful proposer will enter into a contract with the City by April 22, 2015.

4.8 Term

The contract term will end on June 01, 2015, or a date negotiated as part of the contract.

4.9 Compensation

The final contract will be negotiated based on FIXED FEE PRICE with 5 % allowed for unforeseen change orders.

SECTION V GENERAL INFORMATION

5 General Information

5.1 Compliance with the Rules

Proposers responding to this RFQ must follow the procedures and requirements stated in the RFQ document. Contracting with City of West Linn shall be subject to City public contracting rules except as otherwise provided in the City governing charter. Adherence to the procedures and requirements of this RFQ will ensure a fair and objective analysis of your quotation. Failure to comply with or complete any part of this RFQ may result in rejection of your quotation.

5.2 Quotation Withdrawal

Any quotation may be withdrawn at any time before the quotation due date and time, by providing a written request for the withdrawal of the quotation to the issuing office. A duly authorized representative of the firm shall execute the request. Withdrawal of a quotation will not prejudice the right of the proposer to file a new quotation.

5.3 Addenda

The City may modify the RFQ at any time at least five (5) days prior to the RFQ due date, by issuance of an electronic addendum to all proposers who are participating in the process at the time the addendum is issued. Verbal modifications to the RFQ specifications shall not be binding upon the City.

5.4 Cancellation, Delay or Suspension of Solicitation; Rejection of Quotations

The City may cancel, delay, or suspend this solicitation if in the best interest of the City as determined by the City. The City may reject any or all quotations, in whole or in part, if in the best interest of the City as determined by the City.

5.5 Irregularities

The City reserves the right to waive any non-material irregularities or information in the RFQ or in any quotation.

5.6 Incurred Costs

The City is not liable for any costs incurred by a proposer in the preparation and/or presentation of a quotation.

5.7 Ownership of Documents

Any material submitted by a proposer shall become the property of the City. Materials submitted after a contract is signed will be subject to the ownership provision of the executed contract.

5.8 Confidentiality of Information

All information and data furnished to the proposer by the City and all other documents to which the proposer's employees have access during the preparation and submittal of the Quotation shall be treated as confidential to the City. Any oral or written disclosure to unauthorized individuals is prohibited.

5.9 Public Record

Any portion of a quotation that the proposer claims constitutes a "trade secret" or is "confidential" must clearly identify such material, keep it separate, and provide separate notice in writing of the status of this material to the official RFQ contact.

All quotations and information submitted by proposers are open for public inspection.

Clearly marked sample work or documents illustrating previous work experience will be returned to proposers after the evaluation and award process upon written request.

5.10 Equal Opportunity Policy for Contractors

The City of West Linn requires all proposers to comply with equal opportunity policies. The City of West Linn's programs, services, employment opportunities, and volunteer positions and contracts are open to all persons without regard to race, religion, color, national origin, sex, sexual orientation, age, marital status, handicap, or political affiliation. A copy of the City's policy is available upon request.

5.11 Miscellaneous Licenses/Permits

The selected proposer will be required to obtain a business license if work is performed within the City of West Linn.

5.12 Minimum Qualifications

The firm and all applicable personnel must be legally qualified in the State of Oregon (i.e. be appropriately licensed or certified) to practice the work proposed to be performed.

5.13 Recyclable Products

Proposers shall use recyclable products to the maximum extent economically feasible in the preparation of the Quotation and in the performance of the work set forth in this RFQ. Quotations shall be easily recyclable. Plastic and wire bindings are discouraged.

SECTION VI EXHIBITS

6 Exhibits & Design Specifications

6.1 Exhibit 1 – Defined Scope of Work

Purpose of System Design

The Client needs an upgrade to their existing chambers AV system. The redesign shall allow for digital signal transmission, as well as digital recording while allowing for wide screen aspect ratio on the presentation screen. The system shall also be capable of audio conferencing and full automated control that is accessible via LAN. Voting and Request to speak functions for the dais location shall be present as well.

The Awarded Contractor shall provide a complete and working system for the price submitted REGARDLESS of any design flaw, missed equipment, or any issue missed in this design. All submissions design completeness and functionality are to be confirmed by the bidding party BEFORE submission and are the sole liability of the awarded Contractor. If a design/functionality change is suggested, it shall be stated in the submitted bid package. There are to be NO equipment substitutions. Awarded Contractor assumes ALL liability for system functionality

The completed system shall have an easy to understand and use “Quick Start” Guide. This final system design document and associated materials have come about through multiple Client meetings and discussions in which system design functionality and overall room layout were agreed upon.

Inclusions

This Statement of Work includes the following:

1. Scope of Work to be Performed by Contractor:
 - Video System
 - Program Audio System
 - Control System
 - Projection Screen System
 - Equipment Rack System
 - Voting/Request To Speak System
 - Low Voltage Cabling/Install/Removal

6.2 Exhibit 2 – Video System

Part 1: Video System

The Contractor shall provide the labor and materials necessary to install one (1) video/data projector as well as one (1) digital video/audio systems switcher for the transportation of video presentation content. The switcher shall be capable of 1280x800 pixel computer resolution as well as 720p video resolution.

The Contractor shall mount one (1) 5000 lumen multimedia projector with an appropriate lens and digital input. This device shall be mounted using a standard suspended 1.5” NPT and flange with a custom projector ceiling mount. The current projection location shall be reused as well as the existing cable path

The Contractor shall provide the labor and materials necessary to install one (1) digital scaling audio/video switcher capable of passing and scaling resolutions up to 4k computer resolutions and 2K video resolution. The system shall be capable of analog VGA as well as fully digital HDMI input. The locations for input shall be at the clerk/staff location (clerk PC located in the head end A/V rack, with DUAL output card), testimonial location (one (1) VGA and one (1) HDMI input transmitted via CAT5 transmission balun) and at the Clerk/Staff location (one (1) VGA and one (1) HDMI input transmitted via CAT5 transmission balun). The switcher shall also get one (1) digital input from the in house TV facility, one (1) Apple TV input (**Apple TV PROVIDED BY OTHERS**) one (1) Judge PC input (provided by client) one (1) court clerk PC (provided by client) and one (1) Crestron Airmidia appliance. DVD playback shall be via the clerk computer. A feed of the video projection on the in room electric screen shall also be fed to the TV studio in the back of the room for broadcast. There shall be no resolution degradation from the transmission source and the content shall transmit and be received digitally.

The Contractor shall provide two (2) 4” deep cut-in floor boxes to house ten (10) mic inputs as well as one (1) HDMI and one (1) VGA with Audio input as well as client provided data and power **ALL PENETRATIONS CONCRETE CUTTING AND CONDUIT BY OTHERS.**

6.3 Exhibit 3 – Audio System

Part 2: Audio System

The Contractor shall provide the labor and materials necessary to install two (2) compact line array speakers for audience sound re-enforcement. Speakers shall be located on the left and right soffit locations just forward of the testimonial location. Exact placement shall be confirmed on site. Placement shall allow high gain before feedback. Speakers shall be wired as parallel and use channel one of the OFE Crown X1000 audio amplifier. KTAV shall also provide two (2) wall mount speakers mounted behind the compact line array speakers for dias and testimonial coverage. Speakers shall be wired in parallel and utilize channel 2 of the OFE audio amplifier.

The Contractor shall provide that labor and materials needed to install seven (7) new goose neck microphones with individual mute switches into the dias. New audio wiring shall be installed as well as request to speak and voting buttons.

The Contractor shall provide the labor and materials necessary to install one (1) 12 x 12 automated mic mixer with telephone hybrid and echo cancelling per channel capability, one (1) 12 x 12 automated mic mixer with echo cancelling capability and one (1) 12 channel mic/line extender. This will control twenty (20) hardwired mic channels in the floor boxes, two (2) combination HH/Lav mic systems and the audio input from the switching system.

The Contractor shall provide the labor and materials necessary to install twenty (20) hard wired microphone connections. There will be ten (10) located in the testimonial floor box location and ten (10) located in the clerk/staff location. These shall be via custom plate. See plate elevation from specifics.

The Contractor shall provide the labor and materials necessary to install one (1) wireless microphone antenna distribution system. The amplifier shall reside in the head end rack system with the wireless receivers. The antennas shall be remotely located within the dias chambers.

6.4 Exhibit 4 – Control System

Part 3: Control System

The Contractor shall provide the labor and materials necessary to install and configure the following control system components and programming:

1. Points Of Control:

One (1) iPad touch panel surface (**iPad and iTunes account PROVIDED BY OTHERS**)
iPad to be mounted desk top stand

One (1) virtual X-Panel for IP based remote control.

2. One (1) system controller capable of controlling the A/V system components and communicating with its associated touch panel. This control processor is a hybrid unit that is embedded with the audio/video switcher/scaler. The Control System shall control the following items:

- a. Display – Power and Input Selection
- b. System Switching
- c. Audio level control – Graphical Feedback, Speaker Mute, Microphone Mute
- d. System Power
- e. Audio Conferencing – Dial, Hang-up and Flash
- f. Screen Up/Down

6.5 Exhibit 5 – Projection Screen System

Part 4: Projection Screen System

The Contractor shall provide one (1) 69" x 110" tab tensioned on wall electric screen. This screen shall be 16:10 aspect ratio with matte white fabric. The screen shall be mounted to the beams located over the dias location and drop in front of the existing

6.6 Exhibit 6 – Equipment Rack System

Part 5: Equipment Rack System

The Contractor shall reuse all existing rack enclosures, wire management, and power distribution. Equipment location within the existing rack shall be coordinated with TVCTV as to not cause issue with the existing TV system. Locations to be confirmed on site at time of install.

6.7 Exhibit 7 – Request to Speak/Voting System

Part 7: Request to Speak/Voting System

The Contractor shall provide the labor and materials to install one (1) Alzatex voting system. The system shall utilize the existing request to speak/mic mute buttons. Project management/direction of the installation of the voting system to be overseen by Alzatex. Refer to drawings for connection.

Control of the voting system shall be through its proprietary remote. The existing count down timer currently located in the chambers shall be reused.

6.8 Exhibit 8 – City Supplied Goods/Services

The following items are NOT considered to be within the Scope of Work for The Contractor.

- Provision of any additional AV components other than noted in the proposal.
- PC or lap top computers are to be furnished by client only.
- The Contractor will not do, or be liable for, any structural construction, furniture modification or painting.
- All telcom, internet, and cable TV (Comcast etc.) connections are solely the responsibility of the client.
- All alteration of existing flooring or ceiling structure to accommodate cable paths are the client's responsibility.
- Any/all needed conduit or electrical line voltage supply to be the responsibility of the client

6.9 Exhibit 9 – Additional Considerations

The Contractor shall ensure that there are no defects in either the audio or video signal quality and, to the extent that The Contractor has control over the physical and electrical conditions that affect that quality of signal, shall correct any conditions to bring the signal to an acceptable level and quality.

The Contractor is not responsible for correcting audio signal quality and system control interference caused by other facility sources. Examples include, but are not limited to, Infrared control interference caused by florescent lighting and errant radio signals from communication equipment. The Contractor may, at an additional cost, troubleshoot and recommend necessary modifications to the Client's existing system in order to improve any unforeseen audio or system control issues. These recommended modifications may be in the form of system changes, shielding or facility modifications.

The Contractor is not responsible for correcting improper facilities electrical conditions (dirty power) that may contribute negatively to the audio or video reproduction quality nor shall The Contractor be responsible for any damage to the equipment caused by Client or any of their other contractors The Contractor may, at an additional cost, troubleshoot and recommend necessary modifications to the Client's existing system in order to improve any unforeseen problems with audio or video signal quality due to facilities wiring issues. These recommended modifications may be in the form of facility electrical wiring modifications or the addition of ground isolation devices.

All material is guaranteed to be as specified. All work is to be completed in a workmanlike manner according to standard practices. Any alteration or deviation from written specifications involving extra costs shall be executed upon written Change Order, and shall be subject to an additional cost over and above the stated cost set forth in this document. All agreements and schedules are contingent upon strikes, weather delays, accidents or other delays beyond the Contractor's control.

6.10 Exhibit 10 – Video System Hardware Specifications

VIDEO SYSTEM			
DESCRIPTION	BRAND	MODEL	Qty
Video/Data Projector	Eiki	LC-WXL200AL	1
1280x800 Native Resolution, 5500 ANSI Lumens			
Custom Lens for	Eiki	AH-24771	1
Inverted Projector Mount	Eiki	0173-4343	1
Council Monitor HDMI DA6	Extron	60-999-01	1
6' HDMI Cables	Liberty	E-HDSEM-M-02	6
33' HDMI Cables	Liberty	E-HDSEM-M-10	7
6' VGA Cable With Audio	Liberty	E-MVGAM-M-6	4
HDMI to SDI Converter (Switcher to TV)	APPENTEK	DA-HDTV-SDI	1
Cut In floor Box, 4" deep	FSR	FL-600P-4-B	2
Top for cut in floor box	FSR	FL-600P-BLP-C	2
Custom Clerk Panel	Panel Crafters	WQ368341	1
Custom Floor Box Panel	Panel Crafters	WQ368342	1

6.11 Exhibit 11 – Program Audio System Hardware Specifications

PROGRAM AUDIO SYSTEM			
DESCRIPTION	BRAND	MODEL	Qty
Mic Mixer/Phone Hybrid	Clear One	880T	1
Mic Mixer	Clear One	880	1
Mic Mixer Extender	Clear One	8I	2
VoiP Dialer	Clear One	VH20	1
18" Goose Neck Mic with Mute Switch	Shure	MX418S/C	7
18" Goose Neck Table Top Mic	Shure	MX418D/C	12
Wireless Hand Held /LAV System	Shure	SLX124/85/SM58-H5	2
Wireless Mic Distribution	Shure	UA844SWB	1
1/2 Wave Antennas	Shure	UA820D	2
Audio Amplifier	Crown	X1000	1
Digital Audio Recorder	Denon	DN-700R	1
Compact Line Array/House Speaker	TOA	HX-5	2
Compact Line Array/House Speaker Wall Bracket	TOA	HY-Cw1B	2
Dias Monitors	Soundtube	SM400i-WH	2
72 mhz ADA Receivers	Genther	910-402-003	4

6.12 Exhibit 12 – Control System Hardware Specifications

CONTROL SYSTEM			
DESCRIPTION	BRAND	MODEL	Qty
Digital System Switcher	Crestron	DM-MD 16x16	1
4K HDMI Input Card	Crestron	DMC-4K-HD	4
DM Input Cards	Crestron	DMC-C	2
HD-SDI Input Card	Crestron	DMC-SDI	1
DM Output Cards	Crestron	DMC-4K-CO-HD	6
PoE Power Injector	Crestron	DM-PSU-16	1
DM HDMI/VGA Baluns	Crestron	DM-TX-201-C	2
Mainframe Processor	Crestron	CP-3	1
HMDI DA and Audio De-Embedder	Crestron	HD-DA-2	1
Remote System Baluns	Crestron	DM-RMC-100-C	5
iPad Cradle	Peerless	PTM-400	1
AV Sharing Device Air Media	Crestron	AM-100	1

6.13 Exhibit 13 – Timer/Request to Speak/Voting System Hardware Specifications

TIMER/REQUEST TO SPEAK/VOTING SYSTEM			
DESCRIPTION	BRAND	MODEL	Qty
Button Re-Label	Alzatex	TBD	7
Queuing Station Controller	Alzatex	QUE119B	1
Queuing/Voting System Controller	Alzatex	VTO12A07	1
TBD	Alzatex	DCB410B	1
8 Port Ethernet Switch	Alzatex	TBD	1
Four Digit Display	Alzatex	DSP254B-OAK	1
Vote Results to HDMI Output Adaptor/Council Display	Alzatex	VT301A	1
Vote Results to HDMI Output Adaptor/Audience Display	Alzatex	VT301A	1
Control Room Display	Alzatex	DS512B	1
Microphone Mute Interface Module	Alzatex	MM08A	1
24VDC, 9A Power Supply	Alzatex	PSYM04-120	1
On Site Project Management	Alzatex	Custom	1
Customer Training	Alzatex	Custom	1

6.14 Exhibit 14 – Projection Screen System Hardware Specifications

PROJECTION SCREEN SYSTEM			
DESCRIPTION	BRAND	MODEL	Qty
On Wall Tensioned Electric Screen	Da-Lite	34492	1
69x110" Matte White Fabric 16:10 Aspect			
Low Voltage Control	Da-Lite	40793	1

6.15 Exhibit 15 – Hardware Programing Flow Specifications

Council Chambers

Sources:

- Testimonial VGA
- Testimonial HDMI
- Staff VGA
- Staff HDMI
- Clerk PC (DVD Player in PC)
- Judge PC
- Court Clerk PC
- AirMedia
- TV Cable Feed

Equipment to be controlled:

- Eiki Projector LC-WXL200AL (On, Off, Input)
- Clear One 880T Dialer (source volume up, down, mute, audio conferencing, Mic Up, Down Mute)
- Denon DN-700R Digital Recorder (Record, Pause, Stop, Basic Transport)
- Screen up, down

Control Equipment:

- Crestron CP-3 (In main AV rack)
- Crestron DM-MD 16x16
- Crestron DM-TX-201-C (One at testimonial, one at staff location)
- Crestron DM-RMC-100-C (one for projector, one for dias monitors)
- iPad Touch Screen
- X-Panel

Control/Switching inputs: (See AV1 for port assignments)

Startup:

- Touch panel to wake up.
- “Touch here to begin”
- “What would you like to do?” “Court” “Council”
- Select “Court” and the system un-mutes. Clerk PC routes to monitor 5. Judge PC Routes to Monitor 4

If “Council” is chosen

- “Would you like to use the Projector? Yes, No”
- If “No”, Audio system unmutes for audio only (Audio conferencing, mics.)
- If “Yes”, Projector fires on, screen drops, audio system unmutes and switcher goes to dead input to await system choice.

Sources across the top:

- “ Testimonial VGA”
- “ Testimonial HDMI”
- “Clerk VGA”
- “Clerk HDMI”
- “Clerk PC”
- “TV”
- “Voting”
- “Audio Conference”
- “Air Media”
- “Apple TV”
- “Tech Page”

When a source is selected you have the option to “Send to Projector” or “Send to Dias Monitors”

There will need to be an icon in the upper right of the touch panel of a projector and a flat screen. Under each text will track with the live source being displayed.

Volume controls:

“Program” volume bar on left
“Mic (Global) on right

Sources:

“Testimonial VGA” is chosen

“Send Source to desired location” appears.

User can select “Projector” or “Dias Monitors”

Where ever the source is sent, the text under the icon in the upper right hand corner will reflect the source sent.

Audio shall follow the source sent to the main projection screen

Switcher switches to the testimonial VGA input and associated audio.

“Testimonial HDMI” is chosen

“Send Source to desired location” appears.

User can select “Projector” or “Dias Monitors”

Where ever the source is sent, the text under the icon in the upper right hand corner will reflect the source sent.

Audio shall follow the source sent to the main projection screen

Switcher switches to “testimonial HDMI” input and associated audio.

“Clerk VGA” is chosen

“Send Source to desired location” appears.

User can select “Projector” or “Dias Monitors”

Where ever the source is sent, the text under the icon in the upper right hand corner will reflect the source sent.

Audio shall follow the source sent to the main projection screen

Switcher switches to “Clerk VGA” input and associated audio.

“Clerk HDMI” is chosen

“Send Source to desired location” appears.

User can select “Projector” or “Dias Monitors”

Where ever the source is sent, the text under the icon in the upper right hand corner will reflect the source sent.

Audio shall follow the source sent to the main projection screen

Switcher switches to “Clerk HDMI” input and associated audio.

“Clerk PC” is chosen

“Send Source to desired location” appears.

User can select “Projector” or “Dias Monitors”

Where ever the source is sent, the text under the icon in the upper right hand corner will reflect the source sent.

Audio shall follow the source sent to the main projection screen
Switcher switches to “clerk PC” input and associated audio.

“TV” is chosen

“Send Source to desired location” appears.

User can select “Projector” or “Dias Monitors”

Where ever the source is sent, the text under the icon in the upper right hand corner will reflect the source sent.

There will be no audio associated with this input.

Switcher switches to “TV” input.

“Audio Conference” is chosen

Audio Conference Controls (10 key, On-Off Hook, Flash Etc.) appear in the middle of the screen.

Audio conference volume bar appears to right of controls.

Switcher stays on last selected input and associated audio.

“Air Media” is chosen

“Send Source to desired location” appears.

User can select “Projector” or “Dias Monitors”

Where ever the source is sent, the text under the icon in the upper right hand corner will reflect the source sent.

Switcher switches to “Air Media” input.

“Apple TV” is chosen

“Send Source to desired location” appears.

User can select “Projector” or “Dias Monitors”

Where ever the source is sent, the text under the icon in the upper right hand corner will reflect the source sent.

Switcher switches to “Air Media” input.

Arrow keys, Menu Key, Play/Pause key pops up in center of touch panel.

“Tech Page” is chosen.

Controls for Projector (on, off, lamp hours)

Screen (Up, Down)

Mic Button (pop up page with graphic of the dias and mic positions). Hit a position and a volume bar pops up with Mute. Mute status will track on touch panel as well as LED on mic base.

6.16 Exhibit 16 – Video and Control Diagram (AV1)

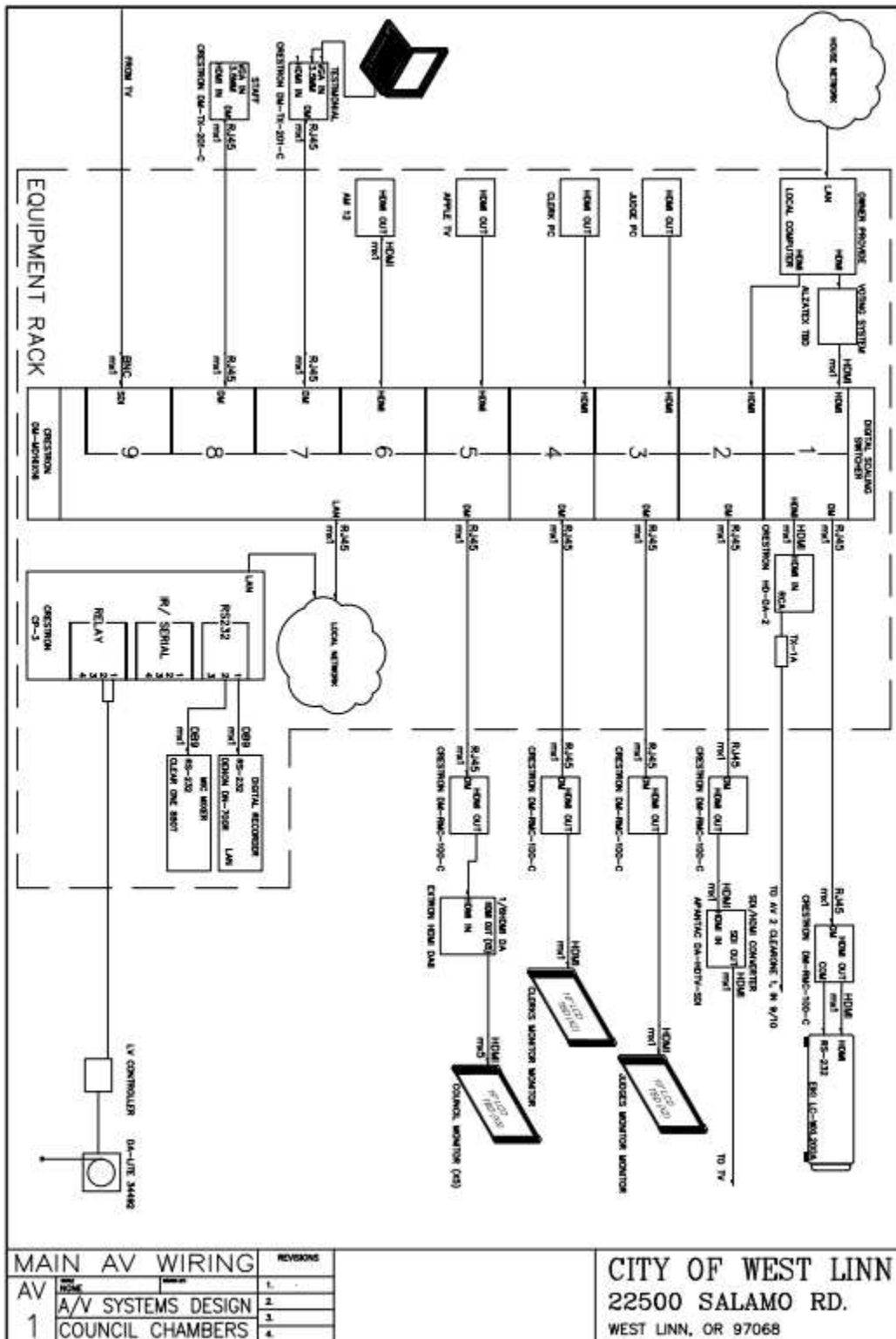

6.17 Exhibit 17 – Audio Control Diagram (AV2)

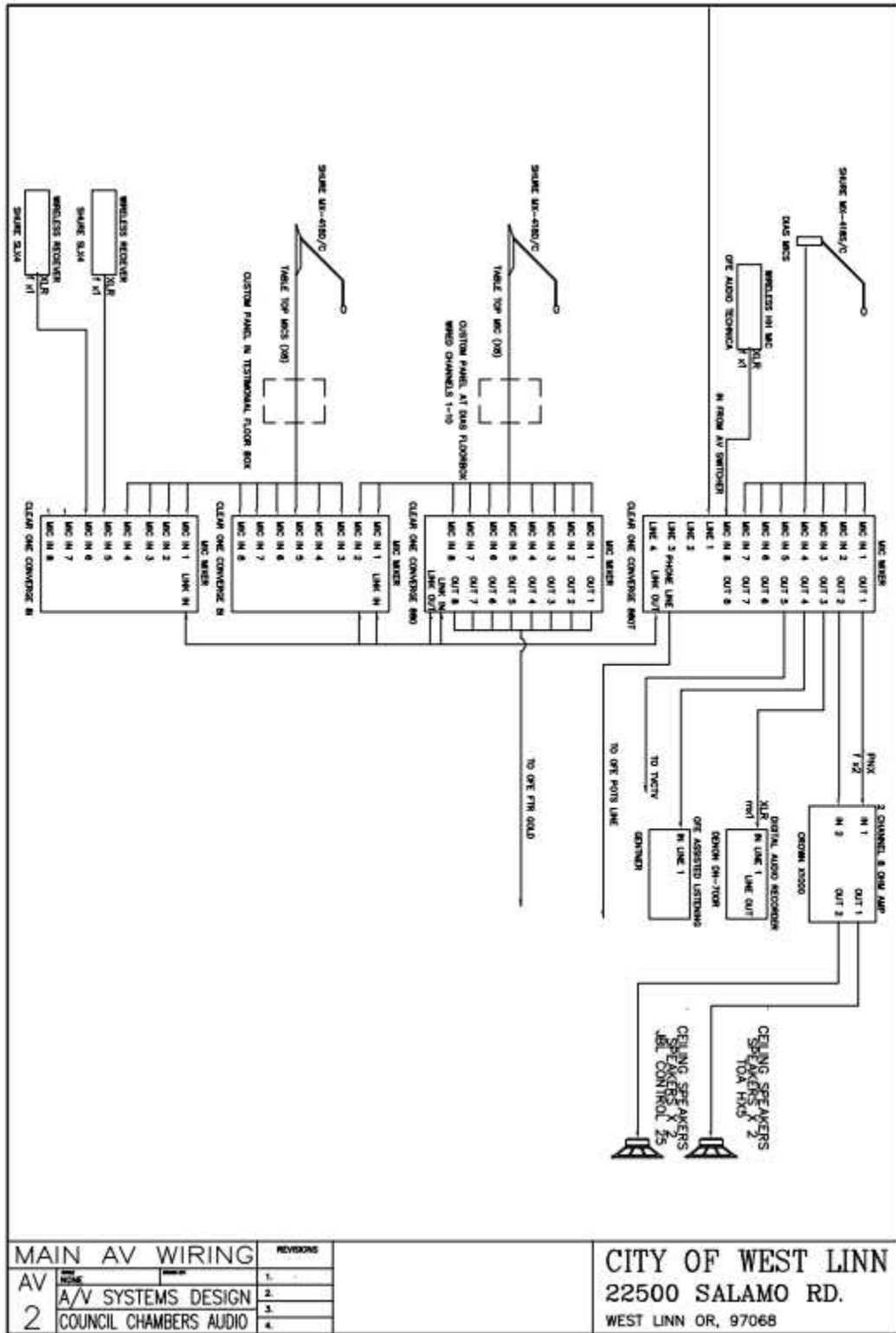

MAIN AV WIRING		REVISIONS
AV	1	1.
2	2	2.
	3	3.
	4	4.

CITY OF WEST LINN
 22500 SALAMO RD.
 WEST LINN OR, 97068

SECTION VII FORMS AND REQUIREMENTS

INSURANCE REQUIREMENTS

To: Proposer. Please provide Certificates of Insurance to the Information Technology Manager. During the term of the contract, please provide Certificates of Insurance prior to each renewal.

During the term of this contract, Contractor shall maintain in force at its own expense all insurance noted below:

Workers Compensation The Contractor, its Subcontractors, if any, and all employers providing work, labor, or materials under this Contract that are subject employers under the Oregon Workers' Compensation Law shall comply with ORS 656.017, which requires them to provide workers' compensation coverage that satisfies Oregon law for all their subject workers. Out-of-state employers must provide Oregon workers' compensation coverage for their workers who work at a single location within Oregon for more than 30 days in a calendar year. Contractors who perform work without the assistance or labor of any employee need not obtain workers' compensation coverage. All non-exempt employers shall provide Employers Liability Insurance with coverage limits of not less than \$500,000 each accident.

Commercial General Liability If Contractor will be installing or testing the goods, or otherwise performing services on City's premises, Contractor shall provide a certificate indicating that Contractor has commercial general liability insurance covering bodily Injury and Property Damage on an "occurrence" form. This coverage shall include Contractual Liability insurance. Coverage will include \$1,000,000 per occurrence and \$2,000,000 general annual aggregate. Said insurance shall name City as an additional insured and shall require written notice to City thirty (30) days in advance of cancellation. If Contractor hires a carrier to make delivery, Contractor shall ensure that said carrier complies with this paragraph.

Commercial Automobile Liability If Contractor will be delivering the goods, Contractor shall provide City a certificate indicating that Contractor has business automobile liability coverage for all owned, hired, and non-owned vehicles. The Combined Single Limit per occurrence shall not be less than \$2,000,000. Said insurance shall name City as an additional insured and shall require written notice to City thirty (30) days in advance of cancellation. If Contractor hires a carrier to make delivery, Contractor shall ensure that said carrier complies with this paragraph.

Notice of Cancellation or Change. There shall be no cancellation, material change, reduction of limits or intent not to renew the insurance coverage(s) without 30 days written notice from the Contractor or its insurer(s) to the City. This notice provision shall be by endorsement physically attached to the certificate of insurance.

Additional Insured. For general liability insurance and automobile liability insurance the City, and its agents, officers, and employees will be Additional Insured's by endorsement, but only with respect to Contractor's services to be provided under this contract. This coverage shall be by endorsement physically attached to the certificate of insurance.

Certificates of Insurance. Contractor shall furnish insurance certificates acceptable to City prior to commencing work. The certificate will include the deductible or retention level and required endorsements. Insuring companies or entities are subject to City approval. If requested, copies of insurance policies shall be provided to the City. Contractor shall be responsible for all deductibles, self-insured retention's, and/or self-insurance.

Quotation Certification Statement

All Quotations must include this certification statement signed by a duly constituted official legally authorized to bind the applicant to both its Quotation and cost schedule.

- A. Any proprietary information has been clearly marked.
- B. Quotation and cost schedule shall be valid and binding for forty five (45) days following the Quotation due date or any revised quotation submission date, whichever is later, and will become part of the contract that is negotiated with the City.
- C. The proposer has not and will not discriminate against a subcontractor in the awarding of a subcontract because the subcontractor is a minority, women, or emerging small business enterprise.
- D. The proposer certifies that this Quotation has been arrived at independently and has been submitted without collusion designed to limit independent bidding or competition.

Proposer's Signature

Date

Print Name

Title

Proposer's Federal Taxpayer Identification number: _____

This certification statement must be signed and submitted with the Quotation.

CERTIFICATION STATEMENT FOR INDEPENDENT CONTRACTOR

I. INDEPENDENT CONTRACTOR STANDARDS

As used in ORS chapters 316, 656, 657, 671 and 701, "independent contractor" means a person or business entity that provides services for remuneration and who, in the provision of the services, meets the following criteria of ORS 670.600.

II. BASIC REQUIREMENTS

1. The Contractor is free from direction and control over the means and manner of providing the services, subject only to the right of the City to specify the desired results;
2. The Contractor is customarily engaged in an independently established business;
3. The Contractor is licensed under ORS chapter 671 or 701 if the person provides services for which a license is required under ORS chapter 671 or 701; and
4. The Contractor is responsible for obtaining other licenses or certificates necessary to provide the services.

III. ADDITIONAL REQUIREMENTS

For purposes of Section II above, a person is considered to be customarily engaged in an independently established business if any three of the following requirements are met. **(Check three or more of the following:)**

_____ The Contractor maintains a business location:
(a) That is separate from the business or work location of the person for whom the services are provided; or
(b) That is in a portion of the person's residence and that portion is used primarily for the business.

_____ The Contractor bears the risk of loss related to the business or the provision of services as shown by factors such as:
(a) The person enters into fixed-price contracts;
(b) The person is required to correct defective work;
(c) The person warrants the services provided; or
(d) The person negotiates indemnification agreements or purchases liability insurance, performance bonds or errors and omissions insurance.

_____ The Contractor provides contracted services for two or more different persons within a 12-month period, or the person routinely engages in business advertising,

solicitation or other marketing efforts reasonably calculated to obtain new contracts to provide similar services.

_____ The Contractor makes a significant investment in the business, through means such as:

- (a) Purchasing tools or equipment necessary to provide the services;
- (b) Paying for the premises or facilities where the services are provided; or
- (c) Paying for licenses, certificates or specialized training required to provide the services.

_____ The Contractor has the authority to hire other persons to provide or to assist in providing the services and has the authority to fire those persons.

IV. INDEMNIFICATION

If any action is taken by a person or enforcement agency relating to the independent contractor status of Contractor or Contractor's subcontractors in connection with this contract, Contractor shall defend, hold harmless and indemnify the City of West Linn, its elected and appointed officials, employees, volunteers and agents from any such action, claim, judgment, fine, penalty, or order to pay. Contractor shall pay any additional costs incurred by the City in defending such action or incurred as a result of such action. This indemnification is in addition to any indemnification otherwise in this agreement.

V. CERTIFICATION

Contractor and Project Manager certify that the above statements are true and correct.

Contractor Signature

Date

Project Manager Signature

Date