

# Boatswain's Pipe

State University of New York  
**Maritime College**

# “Boatswain’s Pipe” 2013 Edition of the MUG Book

Cadet’s Name \_\_\_\_\_

Room No. \_\_\_\_\_

Key No. \_\_\_\_\_

Indoctrination Section \_\_\_\_\_

Platoon \_\_\_\_\_

Company \_\_\_\_\_

Student ID No. \_\_\_\_\_

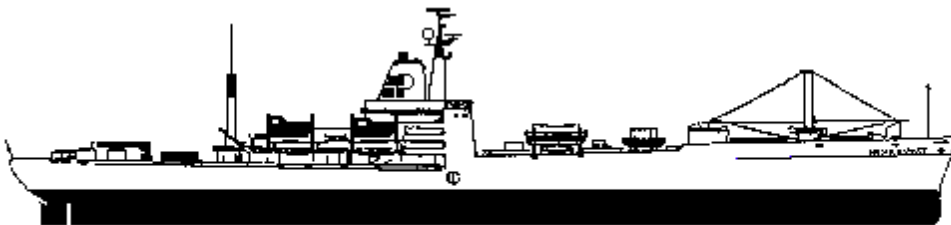

This book was created by the efforts of many Maritime College Cadets, past and present, and is dedicated to help incoming MUGs make their transition to Maritime College and the Regiment of Cadets.

**"One Hand"**

# Introduction

## President's Welcome

As the 10<sup>th</sup> President of the State of New York Maritime College, it is my privilege to welcome you to our nation's First and Foremost such institution. Steeped in more than 125 years of tradition and a proud history that runs deep and strong, the Maritime College remains a premier institution and a global leader in the field of maritime education and training. We intend to maintain such leadership through a continuing process of strategic improvement of our programs and facilities as well as key engagements and focused outreach to leading industries and academic institutions across a variety of fronts, both nationally and internationally.

I can state without reservation that few colleges offer you the combination of such a highly respected academic degree with a strong, hands-on practical component (including Summer Sea Terms onboard our training ship Empire State VI), the opportunity to obtain a Merchant Marine officer's license, a commission in the armed services if you choose, and the unsurpassed leadership opportunities available in the Regiment of Cadets. Indeed few such opportunities in life allow you to grow so rapidly and develop both leadership and technical competencies, which are in high demand in today's globally integrated and complex environment.

As a new cadet entering the regiment at SUNY Maritime College, you join a highly distinguished group of men and women who have lived and carried forward the ideals, strong character and sense of purpose and traditions of this great institution.

You are now a brand new "MUG" and it may appear that the path to graduation is a long and difficult one. However, when you can envision the end result and what you will ultimately be able to achieve by overcoming the challenges that lie ahead, you will appreciate that the effort and energy required to successfully complete this program is well worth it.

Successful completion of the program is a daunting task, which demands inner character and mental toughness. You will be tested fully and not everyone will meet the demands of that test. It is incumbent upon you to take full responsibility now for your success and understand the path upon which you are embarking, as well as the commitment to the Regimental life and core values with integrity being the bedrock.

I urge you to take full advantage of all the opportunities available here at Maritime. Work actively to mature socially, develop physically and excel in the academics and team experiences that are woven into the life of the Regiment and the Maritime College environment. You will be sharing experiences and overcoming challenges that will result in relationships that will span your lifetime and pay dividends you cannot imagine.

Congratulations on choosing New York Maritime and the Regiment of Cadets for your college experience. Life is about choices and making the most of opportunities. You have made a choice that will open many doors of opportunity to you both now and in the future, and equip you to succeed in an ever-changing world. It will not be easy, but when you graduate from New York maritime College, your opportunities will be unlimited!

Welcome Aboard!

WENDI B. CARPENTER  
Rear Admiral, USN (Ret.)  
President

STATE UNIVERSITY OF NEW YORK  
**MARITIME COLLEGE**  
Fort Schuyler, Bronx, NY 10465-4198

**To:** Fourth Class Cadets  
**From:** Chief Indoctrination Officer  
**Subject:** *Boatswain's Pipe*

The *Boatswain's Pipe* provides general information for the orientation of fourth-class cadets. This publication, in conjunction with the Rules and Regulations and information provided by Indoctrination Officers, should direct the daily routine of a fourth class cadet.

The Rules and Regulations Manual for the Regiment of Cadets is the final reference for all policies governing cadet conduct. The *Boatswain's Pipe* is only a supplement to these Rules. All cadets are required to be aware of their responsibilities and will adhere to all regulations.

Questions concerning the specific meaning of anything found in this publication are to be directed to your Indoctrination Officers or Squad leaders.

## The Mission of the Maritime College

### Mission:

- Maritime College educates leaders to excel in the global maritime environment through an interdisciplinary approach to undergraduate and graduate studies in engineering, maritime studies, global maritime business, security and supply chain management, and environmental science; specialized programs are offered as pathways to US Coast Guard licensing or military accession and training.

### Vision:

- Be “First and Foremost”: SUNY Maritime College is a premier institution recognized internationally for its expertise in global maritime research, development, education, and training. Towards that end, the College delivers exceptional quality learning worldwide to meet the “*any time, any place*” needs of the maritime community.

### Guiding Principles:

- Inspire the pursuit of excellence in all things, developing the SUNY Maritime nation to seek the highest standards of intellectual inquiry, scholarly achievement, ethics and integrity, built on the foundation of strong character and a philosophy of service before self.
- Equip all students with the necessary function to reach their fullest potential, whether through participation in the Regiment of Cadets or the Civilian student experience.
- Challenge our students to develop analytical and communication skills that will enable them to dissect complex patterns in emerging issues render reasoned judgments and make wise decisions.
- Develop a community characterized by outstanding leadership, responsible citizenship and self-discipline.
- Foster an innovative, hands-on learning environment directed by a faculty empowered and devoted to creatively seeking new discoveries.
- Promote the development of an internationally recognized resource of maritime expertise that spans all the disciplines associated with the maritime industry and environment.
- Remain grounded in proven traditions and a unique heritage while embracing the opportunities and transformation required by an evolving and increasingly complex global maritime environment.

## Professional Development

Throughout history, the professions of law, theology, medicine, engineering, education, etc. have been distinguished from other vocations or occupational pursuits by their requirement for specialized education and skills, particularly intellectual skills, and their high standards of performance and conduct. The confidence that the public has placed in these professionals has risen or fallen depending on the ability, or willingness, of these professionals to maintain their distinguishing characteristics. Certainly, the decline in illiteracy throughout the modern world has diminished the exalted position of teachers, and scholars who once were distinguished by their rare ability to read and write. Scandals have undermined the public's support in some professions.

The academic records and past achievements of Maritime College applicants underwent close and rigorous scrutiny during the selection process. As you read these paragraphs and pursue your career in the years ahead, it will do you well to remember those things that have set the professional apart from all the others. The specialized skills and high professional standards you will gain over the next four years will be the keys to your future success as a “Domer”, enabling you to overcome the many challenges which lay ahead.

## Leadership

Why lead? As a ship's officer, a foreman, a manager, or a Naval or Marine Corps officer, subordinates will naturally turn to you for decisions, advice, solutions, and leadership. The responsibility for providing leadership is yours. It goes hand-in-hand with the position so be prepared to assume responsibility when it comes.

At other times you may find yourself as one of the many faces in the crowd: an employee, a student, or a citizen. Why lead? If you are like most people, you will have your own opinions about the right and wrong way of doing things. You will believe your methods offer the way to success. Only if you can influence, persuade, and lead others to your way of thinking will your plans be implemented. Even from a follower position you can still exercise leadership ability.

Douglas Southall Freeman, biographer of Robert E. Lee and author of *Lee's Lieutenants*, said that leadership essentially boils down to three fundamentals, "knowing your job, being a strong, capable person, and looking out for the welfare of

your subordinates." Peers and subordinates alike will follow you willingly and confidently as long as they believe you know what you are doing, you are known for your honesty and moral courage, and you care about their welfare. Violate any of these three precepts and you will have difficulty in getting the job done. Although organizations and institutional styles differ, your ability to harness the talents and efforts of your subordinates and wield them effectively in achieving your goals will rest on how well you can develop your leadership ability. There are no "born leaders." Although some leaders have "natural" physical and mental attributes, leadership ability is mainly acquired by observation, emulation, and practice. The following are important leadership traits. Study them, evaluate yourself, and work to improve your gaps.

1. **INTEGRITY:** Be truthful in word and deed. Maintain high moral standards. It is a way of life. When you give your word, all that know you as possessing integrity will take it at face value.
2. **KNOWLEDGE:** Know your job. The more you know, the more faith others will put in you. When you know your job, you can also educate your subordinates so that they will learn their jobs as well.
3. **COURAGE:** Say what you mean and mean what you say. Admit mistakes! Stand up for what you believe in at all times and learn to say, "no, that is not right" to improper behavior. Real courage is moral courage.
4. **ENDURANCE:** Develop your ability to withstand physical and mental stress. Force yourself to work and study even when you are tired. Push yourself to the limit. Remember that what you get out of something is equal to what you put into it.
5. **UNSELFISHNESS:** Give credit to those who deserve it. Share hardships equally with subordinates. If your subordinates are cold, wet, and hungry, then you also should be that way.
6. **LOYALTY:** Loyalty is a two way street. Back-up your superiors. Avoid criticism. Back your subordinates as well. If they are right, then say so.
7. **JUDGMENT:** Judgment comes with experience. Seek advice from others when you need it, but keep the responsibility for your decisions to yourself. Lean hard on those who continually flaunt the law, but be compassionate and forgiving of a good person who has erred.

## **Traditions and Duties**

The SUNY Maritime College has long maintained a military standard which the Regiment, Staff, and Faculty can be proud of. Accordingly, Fourth Class Cadets must observe the deepest respect for the traditions of this institution. These standards and traditions are maintained not only to instill self-discipline, provide leadership, experience, and training, but also to continue the tradition of the Merchant Marine, as it was when the Maritime College was founded in 1874.

# Table of Contents

	<b>Page No.</b>
History of Fort Schuyler	1
History of New York Maritime College	1
Administrative Officers	2
Organization of Cadet Officers	3
Indoctrination Officers and Squad leaders	4
Military Courtesy	6
Military and Social Etiquette	10
Uniforms	12
MUG Path	20
Cadet Quarters	22
MUG Responsibilities	27
The Commercial Maritime Industry- “Our Business”	30
Nautical and Maritime College Terminology	36
MUG Knowledge	40
The Training Ship	47
Telephone Numbers	54



# History of Fort Schuyler

Fort Schuyler, constructed between 1833 and 1845, was named in honor of the Revolutionary War hero, Major General Philip John Schuyler. Schuyler commanded the Northern Army in 1777, and later served as a United States Senator. Built of Connecticut granite in the shape of an irregular pentagon, Fort Schuyler is considered the finest example of French-type fortification in the United States.

Fort Schuyler, along with Fort Totten at Willet's Point, was intended to protect New York City from a naval attack from the east. Fort Schuyler's five-sided design, coupled with three full bastions to the east and two demi-bastions to the west, allowed its defenders to fire from any angle. The fort could accommodate a garrison of 1250 men and support an armament of 452 guns.

Conversion to a land-based home for the New York State Merchant Marine Maritime College began in 1934. The Works Project Administration (WPA) was responsible for restorations. Millions of pounds of earth and sod were removed from the original roof and a new concrete roof and mezzanine deck were constructed. The fort's interior was equipped with classrooms, laboratories, and living spaces. Cadets continued to occupy the fort until the completion of Vander Clute Hall in 1961. Today the Fort is listed as both a New York City and National Historic Landmark.

# History of New York Maritime College

The history of the State University of New York Maritime College is a chronicle of progressive development in answer to the changing needs of the maritime industry. During America's first period of growth, between the Revolutionary and Civil Wars, the wealth of the nation depended greatly on its shipping and commerce. American ships, crewed by American seamen, slowly began to challenge England's traditional supremacy on the sea. However, the Civil War (1861-1865) reversed this commercial and maritime growth such that by the end of the war, America's merchant fleet, including coastal shipping, was approximately six percent of its prewar size.

In 1875, only twenty-eight percent of America's imports and exports were carried in American bottoms. As another period of growth began in the post-Civil War period, it became clear that the United States maritime industry needed improvement. American crews generally worked considerably harder, were subject to harsher discipline, and were often in greater physical danger than their foreign counterparts. Such conditions caused many seamen or potential seamen to leave the maritime industry and choose other careers. For the young man who still did want to pursue a life at sea, there was no way to prepare for a seafaring career except by gaining experience on board a ship as a cabin boy, cargo worker, or seaman.

A number of people saw this way of training seamen as far too haphazard and inefficient, and they pointed to European school ships and to the United States Naval Maritime College as far better means of creating a group of competent sailors. One of the groups particularly interested in establishing a nautical school was the New York State Chamber of Commerce. Unable to raise funds from private donors, the Chamber of Commerce petitioned the New York City Board of Education and the State Legislature to pass a bill authorizing the establishment of a maritime school.

On April 24, 1873, the Legislature passed an act empowering New York City, the nation's great seaport, to "provide and maintain a nautical school in said city, for education and training of pupils in the science and practice of navigation." With the advice of Captain (later Rear Admiral) Stephen B. Luce, USN, the foremost expert in the United States on maritime education and training, a curriculum was developed, and the New York Nautical School was thus established in 1874.

The United States Congress approved "An Act to Encourage the Establishment of Public Marine Schools" in June 1874, and shortly thereafter, the 985 ton sloop-of-war *St. Mary's* was assigned to the New York City Board of Education as the Nautical School's first school ship. The first entering class was received on the *St. Mary's* on January 11, 1875, and fifty-eight cadets graduated on November 20, 1876. In 1913, responsibility for the school's operation was transferred from New York City to New York State.

The College has continually responded to the needs of both the maritime industry and the nation. Since the school's inception, Fort Schuyler graduates have served in the Navy and Merchant Marine during every war that saw American involvement. During World War II the academic program was suspended and the curriculum reduced to an eighteen-month program; approximately 2,000 Naval Reserve Officers and 500 Merchant Marine Cadets were then training at Fort Schuyler.

In 1948, the New York State legislature passed a series of acts creating the State University of New York, and the

Maritime College became one of the thirty-two original colleges to join the University System. Today, cadets receive baccalaureate degrees in a number of fields including Naval Architecture, Marine Engineering, Mechanical Engineering, Facilities Engineering, Marine Environmental Science, Marine Transportation, and the Humanities.

Adapted from "A History of the Growth of SUNY Maritime College," by Captain Gerald J. Nolan.

## **Administrative Officers**

President

Master TSES & Commandant of Cadets

Vice President for Operations

Provost & Vice President for Academic Affairs

Dean of Students

Associate Provost & Academic Dean

Dean of Admissions

Director of Waterfront

Director of Campus Ministries

Director of Student Activities

Director of Health Services

Director of Housing and Residential Life

Athletic Director

Chief of University Police

Registrar

RADM Wendi Carpenter USN (Ret.)

CAPT Richard Smith

Elizabeth Praetorius

Dr. Michael Cappeto

Dr. Irene Delgado

Dr. Gilbert Traub

Yamiley Saintvil

Rob Crafa

Peter Pomposello

Ariane Romeo

Cortney Worrell

Travis Killian

Heather MacCollugh

Myron Pryjmak

Sarah Grady

### **Commandant's Staff**

Deputy Commandant of Cadets

Regimental Assistant

First Battalion Officer

Second Battalion Officer

Third Battalion Officer

Regimental Duty Officer

Regimental Operations Officer

Regimental Command Master Chief

Regimental Operations Chief

Regimental Training

CAPT Catie Hanft USN (Ret.)

Joann Sprague

LT Charlie Belmonte

LT COL Mike Stroud

LT Kyle Cridland

LT Andria Thornton

Master Chief Jim Testor

Chief Jason Rodriguez

MSGT Dave Giddens

### **Department Chairs / Directors**

Marine Transportation

Engineering

Science

Humanities

Global Business and Transportation

Professional Education and Training

Naval Science NROTC CO

Library

CAPT Walt Nadolny

Dr. Richard Burke

Dr. Kathy Olszewski

Dr. Karen Markoe

James Drogan

CAPT Ernie Fink

CAPT Matthew Loughlin

Constantia Constantinou

# Organization of Cadet Officers

In order to provide practical training in the command and staff functions of a military organization and to provide leadership and administrative experience during the academic year, the Regiment of Cadets is organized to consist of the Regimental Executive Staff, Specialty Rates, Ship Rates, and three Battalions. Cadet Officers' rank is indicated by sleeve, shoulder board, and collar insignia (shown in parentheses).

## Regimental Executive Staff

Regimental Commander (6 Stripes/Bars) \_\_\_\_\_  
Regimental Chief of Staff & Training Officer (5) \_\_\_\_\_  
Regimental Executive (4) \_\_\_\_\_  
Regimental Operations Officer (4) \_\_\_\_\_

## Specialty Rates

Regimental Logistics & Liaison Officer (4) \_\_\_\_\_  
Regimental Assistant Logistics Officer (3) \_\_\_\_\_  
Regimental Admissions Liaison Officer (3) \_\_\_\_\_  
Regimental Assistant Admissions Liaison Officer (2) \_\_\_\_\_  
Regimental Security Officer (3) \_\_\_\_\_  
Cadet Chief Hospital Corpsman (3) \_\_\_\_\_  
Assistant Chief Hospital Corpsman (2) \_\_\_\_\_  
Cadet Regimental Band Leader (3) \_\_\_\_\_  
Honor Guard Commander (3) \_\_\_\_\_  
Honor Guard Executive Officer (2) \_\_\_\_\_

## Ship Rates

Cadet Chief Officer (4) \_\_\_\_\_  
Cadet Second Officer (3) \_\_\_\_\_  
Cadet Third Officer (3) \_\_\_\_\_  
Cadet Chief Engineer (4) \_\_\_\_\_  
Cadet First Assistant Engineer (3) \_\_\_\_\_  
Cadet Second Assistant Engineer (3) \_\_\_\_\_

## First Battalion

Battalion Commander (5) \_\_\_\_\_  
Company Commander (4) \_\_\_\_\_

**Alpha Company**

**Bravo Company**

Co. Executive Officer (3)	_____	_____
Co. Operations Officer (3)	_____	_____
1st Platoon Commander (2)	_____	_____
2nd Platoon Commander (2)	_____	_____
3rd Platoon Commander (2)	_____	_____

**Second Battalion**

Battalion Commander (5) \_\_\_\_\_

**Charlie Company**

**Delta Company**

Company Commander (4)	_____	_____
Co. Executive Officer (3)	_____	_____
Co. Operations Officer (3)	_____	_____
1st Platoon Commander (2)	_____	_____
2nd Platoon Commander (2)	_____	_____
3rd Platoon Commander (2)	_____	_____

**Third Battalion**

Battalion Commander (5) \_\_\_\_\_

**Echo Company**

**Foxtrot Company**

Company Commander (4)	_____	_____
Co. Executive Officer (3)	_____	_____
Co. Operations Officer (3)	_____	_____
1st Platoon Commander (2)	_____	_____
2nd Platoon Commander (2)	_____	_____
3rd Platoon Commander (2)	_____	_____

**Indoctrination Officers and Squad leaders**

Chief IDOs	Name	Rm. No.
<b>Chief Indoctrination Officer</b>	_____	_____
Chief Deck Indoctrination Officer	_____	_____
Chief Engine Indoctrination Officer	_____	_____
Chief PT Indoctrination Officer	_____	_____
Chief Academic Indoctrination Officer	_____	_____

Chief Squad Leaders	Name	Rm. No.
<b>Chief Squad Leader</b>	_____	_____
Chief Deck Squad Leader	_____	_____
Chief Engine Squad Leader	_____	_____

Chief PT Squad Leader \_\_\_\_\_  
 Chief Academic Squad Leader \_\_\_\_\_

Section _____	Name	Rm. No.
SC IDO	_____	_____
IDO	_____	_____
IDO	_____	_____
SC SL	_____	_____
SL	_____	_____
SL	_____	_____
SL	_____	_____
SL	_____	_____
SL	_____	_____

**Chain of Command**

The Chain of Command defines the authority, responsibility and accountability delegated to each organizational element. It extends from the President of the College to the individual forth class cadet. It is the formal path for information flow in both directions, top down and bottom up. The Chain of Command should be followed as best as possible in the Regiment.

Problems of a personal nature may be taken to any person with whom the cadet feels comfortable. This could be a Squad leader, an IDO, a Chief IDO, a Regimental Duty Officer, Student Life staff, the chaplain, etc.

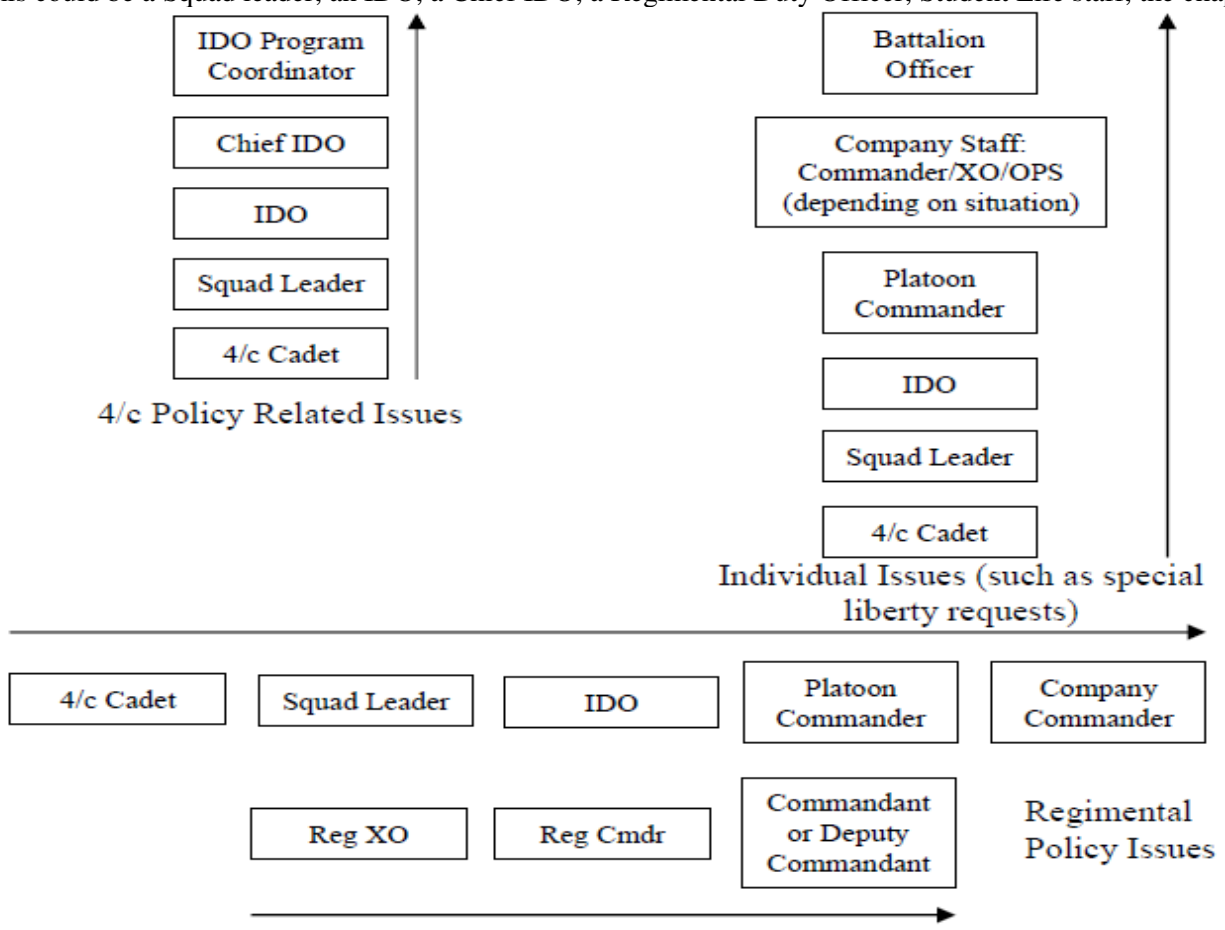

# Military Courtesy

## Position of Attention

The position of attention is the basic military position from which most other drill movements are executed. There are no counts, however, there are seven steps in describing the position:

1. Smartly bring your left heel against the right.
2. Turn your feet out equally to form an angle of 45 degrees. Keep your heels on the same line and touching.
3. Your legs should be straight, but not stiff at the knees.
4. Keep your hips and shoulders level and your chest lifted.
5. Your arms should be straight, but not stiff at the elbows; thumbs along the trouser seams, palms facing inward toward your legs, and fingers joined in their natural curl.
6. Keep your head and body erect. Look straight ahead. Keep your mouth closed and your chin pulled in slightly.
7. Stand still and do not talk.

## Hand Salute

The purpose of the hand salute is to demonstrate mutual respect and courtesy between members of military organizations and to show respect to national colors. A military organization is marked by its efficiency, smartness, bearing, and adherence to honors and ceremonies. Visiting officers and guests of all categories take away an impression formed by the collective total of these various marks of military competency. One mark of importance, which always impresses the visitor, is the hand salute. If the hand salute is rendered properly with respect and deference to the senior individual, then a favorable impression is made. The opposite is achieved by rendering a sloppy salute or no salute at all.

The hand salute is the long established form of greeting and recognition between persons in the Services. It is one of the main aspects of military courtesy and the traditions regulating it are founded on military etiquette and are deeply rooted in the traditions of the Naval and Merchant Services and the Regiment of Cadets. It is emphasized that the salute to a person in uniform is not rendered to the person, but to the uniform the individual wears and the authority represented. The initiation of the hand salute comes from the junior.

Fourth Class Cadets are required to salute all Officers and Cadet Officers of 5-bar rank and higher. All other cadets shall salute all Officers.

A senior Officer passing in an automobile is entitled to a salute, which will be returned when conditions permit. If driving, he will not return a salute when safety is involved. The salute is rendered only once if the senior remains in the immediate vicinity, and no conversation except the greeting takes place. If a conversation does take place, the junior again salutes the senior on departing, or when the senior leaves.

If you are in conversation with an Officer, do not interrupt the conversation to salute another Officer. If the Officer to whom you are talking salutes a senior, then salute.

If in an overtaking situation, the junior shall slow to a walk and salute as he comes abreast of the senior and say, "By your leave, Sir/Ma'am?" The senior shall return the salute and acknowledge the request.

The hand salute is executed in one count when halted at attention, marching at quick time, or seated in a vehicle. The command is "**Hand, SALUTE.**" To return to the position of attention the command is "**Ready, TWO.**"

When "**SALUTE**" is given, raise your right hand smartly in the most direct manner until the tip of your forefinger touches the lower part of the headdress above and slightly right of your right eye. Your fingers should be extended straight and joined with the thumb along the forefinger. You should be able to see your entire palm when looking straight ahead. Your upper arm should be parallel with the deck with the elbow in line with the body and your forearm at a 45-degree angle. Your wrist and hand should be straight, a continuation of the line made by your forearm. At the same time, if not in ranks, turn your head and eyes toward the person or colors you are saluting.

At the command "**TWO,**" return to attention. Move your hand smartly in the most direct manner back to its normal position by your side. To ensure simultaneous execution of the second movement of the hand salute when troops are in formation, the preparatory command "**Ready,**" will be used prior to the command of execution "**TWO.**"

You may salute without command from attention, while walking, or while seated in a vehicle. When walking, it is not necessary to halt to salute. Keep walking, but at attention. If the need arises to salute while double timing, come to a

walking pace before saluting. The salute is rendered when the person or colors to be saluted is at a 6-pace distance, or at the nearest point of approach if it is apparent that the person or color is not going to approach within 6 paces. The salute will not be rendered if the person (color) to be saluted does not approach within 30 paces. Hold the first position of the salute until the person (color) saluted has passed, the salute is returned, or a verbal acknowledgment of the salute is given, then execute the second movement of the hand salute.

If a junior approaches a group (two or more) of Officers, the junior will salute and give the proper greeting. When the command **“Present, ARMS”** is given, if not armed, you execute the hand salute on the command **“ARMS.”** Stay at that position until the command **“Ready, TWO”** or **“Order, ARMS”** is given.

When in doubt, salute. Saluting can never be wrong, whereas not saluting can be construed as disrespectful, slovenly, and unprofessional.



## Greetings

Salutes are usually accompanied by an exchange of greetings, depending upon the time of day. When passing an upper-class cadet that does not warrant a salute, a greeting should be given. The following are standard greetings used throughout the day:

- From morning until 1159: "Good Morning, Sir/Ma'am"
- From 1200 until 1759: "Good Afternoon, Sir/Ma'am"
- From 1800 until turning in: "Good Evening, Sir/Ma'am"

During the Indoctrination period, when time is unknown, the following rules will be used for greetings:

- From morning until before lunch: "Good Morning, Sir/Ma'am"
- From eating lunch until before dinner: "Good Afternoon, Sir/Ma'am"
- From eating dinner until turning in: "Good Evening, Sir/Ma'am"

When greeting a group of officers or cadets, the following greetings are used:

- "Good Morning, Gentlemen"
- "Good Morning, Ladies"
- "Good Morning, Ladies and Gentlemen" or any other necessary combination of Sir, Ma'am, gentlemen, and ladies.

## Honors to the National Anthem

Whenever the National Anthem is played, all cadets not in formation shall stand at attention and face the national ensign. In the event that the national ensign is not displayed, they shall face the source of the music. When covered, they shall come to attention and salute at the first note of the anthem, and shall remain at the salute until the last note of the anthem. Cadets in formation are brought to order arms or called to attention as appropriate.

## Morning and Evening Colors

Morning and Evening Colors (the raising and lowering of the national ensign) are conducted by the Regimental Honor Guard.

Morning Colors are conducted during morning formation. Eight bells are rung on the bell to signify that all is well, and the flag is hoisted up the flag pole at the first sounding of "To the Colors". Cadets not in formation shall come to attention, face the flag, and if in uniform and covered, salute at the ringing of the first bell, holding the salute until the last note of "To the Colors" is sounded. Cadets in formation are brought to order arms or called to attention as appropriate.

Evening Colors are conducted at sunset, typically between 1700 and 2000. The colors detail may command "**Attention to colors**" or may play "Retreat". Upon hearing the command "**Attention to colors**" or the first note of "Retreat", all cadets shall come to attention, face the flag, and if in uniform and covered, salute, holding the salute until the last note of "Retreat" is sounded (which should be when the flag is lowered completely) or until the order "**Carry on**" is given.

## Personal Honors

When personal honors are rendered, military personnel present a salute at the first note of the music and hold the salute until the completion of the ruffles and flourishes march. When a gun salute is rendered, military personnel being saluted and other persons in the ceremonial party will render the hand salute throughout the firing of the gun salute.

## War Memorial

The War Memorial, located in the center of the Fort, honors the Cadets and graduates of the SUNY Maritime College who made the supreme sacrifice in the service of their country during war. In honor of them, a salute is rendered to the War Memorial.

When entering and leaving the flagstone square upon which the War Memorial is located, Cadets and uniformed guests will come to attention and salute the War Memorial.

Cadets will request that their guests, both civilian and military, render the appropriate honors when approaching and leaving the War Memorial.

## Boats, Cars and Aircraft

The procedures for getting in and out of a boat, car and aircraft are similar. Normally, the Senior Officer will enter last and the junior will enter first. This procedure may be reversed in entering a car at a left-hand curb. Then the senior may enter first in order that he or she may sit to the right of the Junior Officer. In a boat, the Junior Officer sits forward and the senior sits aft. In getting out of the boat, car or aircraft, the Senior Officer disembarks first, and the Junior last. However, if a car draws up to a left-hand curb, it may be more appropriate for the Junior to step out first.

## "Attention on Deck"

The first person to notice an officer or senior cadet enter the room will command "**Attention on deck! Billet and/or Rank, Name**" (Example: "**Attention on deck! Commandant of Cadets, Captain Smith**" or "**Attention on deck! Chief IDO, Mr. Jones**") in a sufficiently loud and clear tone. At the command of "attention on deck", all persons in the room or area will come to the position of attention and wait for another command, such as "**seats**", "**carry on**", "**at ease**", etc., or for the officer to leave the room. When the officer leaves the room, the command "**Attention on deck**" (no billet, rank, or name is given when departing) will again be given, and all persons in the room will come to the position of attention until the officer exits.



When more than one person rating an “attention on deck” enters a room, “attention on deck” is only given for the most senior Officer or Cadet.

“Attention on deck” is to be called for the following people:

- All Officers
- Cadet Officers
- Chief IDOs

## **Sounding Off**

When identifying oneself or when ordered to sound off, a fourth class cadet will reply: “Sir/Ma’am, Cadet \_\_\_\_\_ (last name only), Fourth Class, Sir/Ma’am.”

## **General Responses**

During the Indoctrination Period or unless otherwise directed, fourth-class cadets will give the following general responses as appropriate.

"Sir, yes, Sir" *or* "Ma’am, yes, Ma’am"\*

"Sir, no, Sir" *or* "Ma’am, no, Ma’am"

"Sir, no excuse, Sir" *or* "Ma’am, no excuse, Ma’am"

"Sir, I will find out, Sir" *or* "Ma’am, I will find out, Ma’am"

"Sir, I do not understand, Sir" *or* "Ma’am, I do not understand, Ma’am"

\*For a saltier affirmative response, one may reply "Sir, aye, Sir" or "Ma’am, aye, Ma’am" this means that the person being ordered understands and will obey that order.

# **Military and Social Etiquette**

The rules of military and social etiquette are founded on customs and tradition, and their strict observance forms an important factor in the maintenance of discipline. It must be thoroughly understood that respect and courtesy are to be shown equally by all Officers, Cadets and staff of the Maritime College. The junior is the one who should take the initiative. Cadets shall use the information and instructions contained in the book Service Etiquette as a guide for behavior and conduct at all social affairs.

## **General**

The place of honor is always on the right when two people in uniform are walking together; the junior always walks to the left of the senior.

A Junior Officer opens a door for his senior. Junior Officers stand aside for seniors to pass through doors, and then follow.

A man should offer a woman his arm only to give assistance when needed, or as an escort at a formal function. You never grasp or take hold of a woman's arm unless an accident is to be avoided. When you offer your right arm at a formal function, bend your arm slightly at the elbow with your forearm parallel to the floor. Your partner will hold your arm lightly.

At The Maritime College, it must be remembered that Class Rank has precedence, and as such, the customary gender related courtesies are suspended except at formal occasions.

## **Relations With Seniors**

On all occasions, a Cadet shall display toward his senior a spirit of deference and courtesy. It is not practical to define all occasions on which courtesy should be extended. However, every Cadet should be governed by a desire to pay that respect to age and seniority, which pertains to official and social interaction among officers, gentlemen, and ladies. Showing an officer-like and self-respecting demeanor while extending respect and courtesy is invariably noticed and commended such actions are characteristic of good manners and proper training.

## **Relations with Subordinates**

Cadets shall exercise proper professional courtesy and justice in their relations with subordinate Cadets. Gaining, or giving the appearance of gaining, unfair benefits, by the junior from the senior, or vice versa is the definition of fraternization and will not be tolerated.

## **Telephone**

You should always be courteous when talking on the telephone. When answering or placing a call, identify yourself. "Hello" may be used in answering at home, but in an office or on an official occasion, Cadets should answer the telephone saying: "SUNY Maritime College, Location, Cadet Last Name, Class" (example: "SUNY Maritime College, Quarter deck, Cadet Smith, fourth class"). You must always be courteous when making phone calls. Unless necessary, do not call a private residence before nine in the morning or after ten o'clock in the evening. Avoid calling at meal hour. When abused, the telephone is a nuisance. Cadets particularly should remember that it is inconsiderate to engage in lengthy chitchat when others may urgently need to call in. Therefore, conduct your business quickly, and allow others to use the telephone.

## **Email**

Email is an efficient and heavily used way of communication at Maritime College. All cadets are issued an email address upon entering the college.

To access your email account, go to the college home-page, under the "Current Students" tab, go to "Email", and then "OWA." At the login page, enter your username and password.

Example: Name: John Doe  
Social Security Number: 123-45-6789  
Username: johndoe.11  
First Name First 3 Letters of Last Name . 11  
Password: JD-6789  
Initials – Last 4 Numbers of SSN

Maritime College Email is used as an official method of communication, therefore, cadets should be mindful of the emails that they send to officers, professors, and other cadets and keep the email professional and courteous in nature. The proper format for an email is as follows: A proper subject should also be included in the “Subject” field of the email. Subjects should give the person receiving the email an idea of what the email is going to be about, but should be kept short.

The diagram shows an email format with annotations. On the left, the text reads: "Dear Addressee ,", followed by an arrow pointing to the right towards the text "→ Body of the email goes in this area.". Below this is "¶ Very Respectfully," and another "¶" followed by "Cadet First Name Last Name , 4/c". On the right, a box contains the text: "The “addressee” is the person you are sending the email to. If you do not know the name of the person the email is being sent to, replace “Dear Addressee” with “To Whom it May Concern”." An arrow points from this box to the "Dear Addressee ," text.

### Courtesy at Lectures

Lecturers invited to speak to Cadets are generally experts in their field and are highly respected among their colleagues. Inattention by Cadets, as evidenced by sleeping, carrying on a conversation, reading, using a cell phone, or causing any other form of distraction is inconsiderate, and evidence of a lack of self-discipline. Each Cadet is responsible not only for his own conduct, but also for the decorum and attentiveness of the Cadets in the immediate vicinity.

If a Cadet is unable to keep their eyes open during a lecture, it is appropriate to quietly get up, move to the back or side of the room, and remain standing until the conclusion of the lecture. It is more respectful to get up and stand to the side than to fall asleep.

### Good Grooming

A good first impression depends to a great extent upon your personal grooming and may be one of the most valuable assets of your life. It is impossible to foresee which day, what hour, may be that most important event, or what casual meeting may lead to your being accepted or rejected by a person solely based on the first impression you create.

# Uniforms

The uniforms worn at Maritime College are similar to those worn by the United States Navy, the only difference typically being the insignia on the collar or on the sleeve, and the buttons on the Pea Coat and Service Dress Blue Jacket, which say “USMS” (standing for United States Maritime Service). As MUGs, you will be in uniform at all times while on campus, except on the weekends.

The Plan of the Day (POD) or Plan of the Week will dictate which uniform is to be worn. On most days, the uniform of the day will be “standard issue” (Poly-Wool) Khakis. On some days (Admissions Open Houses, Career Fairs, etc.) the uniform of the day will be the in season dress uniform.

## **Poly-Wool Khakis**

This uniform consists of the following items:

1. Poly-Wool Short Sleeve Khaki Shirt
2. Poly-Wool Khaki Dress Pants
3. Poly-Wool Garrison Cap
4. Khaki Poly-Wool Belt
5. Brass Belt Buckle
6. Plain White Undershirt
7. Black Dress Socks
8. Black Leather Shoes
9. Black Shirt-Stays

Optional items authorized for wear with the Poly-Wool Khakis include:

1. Black “Relaxed Fit” Jacket
2. Pea Coat
3. Black Wool Sweater
4. Black Leather Gloves (only to be worn when wearing a jacket)
5. Plain Black Scarf (only to be worn when wearing a jacket, scarf not issued by school)
6. Black Wool Watch Cap (only to be worn when wearing the pea coat)

Care of the Poly-Wool Khakis:

Although the tag on the shirt and pants directs to wash using the “Permanent Press” cycle, over time this will shrink the uniform. Therefore, it is best to wash the poly-wool khaki uniform using the “Cold Water” cycle and drying on the “Low Heat” setting. The poly-wool garrison cap may also be washed using the “Cold Water” cycle and dried on the “Low Heat” setting. After washing and drying, the shirt, pants, and cap should be ironed using the “Polyester” setting on the iron. It is best to test a small, inconspicuous area of the uniform with the iron first, as too hot of an iron will burn the uniform. Spray starch may be used to retain a crisp appearance between ironings. Alternatively, the shirt, pants, and cap may be dry-cleaned.

## **Service Dress Blues (SDB)**

This uniform consists of the following items:

1. Combination Cover
2. Service Dress Blue Jacket
3. Service Dress Blue Pants
4. Long-Sleeve White Dress Shirt
5. Black Poly-Wool Belt
6. Brass Belt Buckle
7. Plain White Undershirt
8. Black Dress Socks
9. Black Leather Shoes
10. Tie, Black (Males only, tied using a Double Windsor knot)
11. Tie Clip (Males only)
12. Tie, Black, Crossover Type (Females only)

Optional items authorized for wear with the Service Dress Blues include:

1. Pea Coat
2. Black Leather Gloves (can be worn with or without the pea coat)

Care of the Service Dress Blues:

The SDB Jacket and SDB Pants should only be dry-cleaned. The Long-Sleeve White Dress Shirt may be washed and dried as per the instructions on the tag. The white cover of the Combination Cover may be removed and washed. Instructions for taking apart the cover are included when it is issued, read and save the instructions.

## **Dress Whites**

This uniform consists of the following items:

- |   |                           |
|---|---------------------------|
| 1. Combination Cover                                    | 6. Plain White Undershirt |
| 2. Certified Naval Twill (CNT) Short-Sleeve White Shirt | 7. White Dress Socks      |
| 3. CNT White Dress Pants                                | 8. White Leather Shoes    |
| 4. CNT White Belt                                       | 9. White Shirt-Stays      |
| 5. Brass Belt Buckle                                    | 10. Soft Shoulder Boards  |

Optional items authorized for wear with the Dress Whites include:

1. Black “Relaxed Fit” Jacket

Care of the Dress Whites:

The CNT Shirt and CNT Pants may be washed and dried as per the instructions on the label. Alternatively, they may be dry-cleaned. The White Leather Shoes will become discolored with use, in order to restore the white color, a leather shoe whitener should be used on the sole and the leather. The white cover of the Combination Cover may be removed and washed. Instructions for taking apart the cover are included when it is issued, read and save the instructions.

## **Boiler Suit**

This uniform consists of the following items:

- |                           |                          |
|---------------------------|--------------------------|
| 1. Blue Bump Cover        | 4. Black Steel Toe Boots |
| 2. Boiler Suit            |                          |
| 3. Plain White Undershirt |                          |

Optional items authorized for wear with the Boiler Suit include:

1. Black Zip-Up Work Jacket
2. Black Wool Watch Cap

Care of the Boiler Suit:

The Boiler Suit will shrink significantly the first few times it is washed, make sure that it is slightly larger than required before washing. Each additional wash will shrink the boiler suit slightly, which should stretch again during wear. Washing using the “Cold Water” cycle and drying using the “Low Heat” setting will help reduce shrinkage of the boiler suit.

## **PT Uniform**

This uniform consists of the following items:

1. Blue-Collar Maritime Shirt
2. Blue Maritime Shorts
3. Blue Maritime Ball Cap
4. White Socks
5. Sneakers

Optional items authorized for wear with the PT Uniform include:

1. Black Wool Watch Cap
2. Grey Maritime Hooded Sweatshirt
3. Grey Maritime Sweatpants
4. Stenciled White-Collar PT Shirt

Care of the PT Uniform:

All uniform components should be washed and dried as per the instructions on the tag.

## **Salt and Peppers**

The “Salt and Peppers” uniform is typically the dress uniform authorized for wear during Summer Sea Term. This uniform consists of the following items:

1. Combination Cover
2. CNT Short-Sleeve White Shirt
3. Service Dress Blue Pants
4. Black Poly-Wool Belt
5. Brass Belt Buckle
6. Plain White Undershirt
7. Black Dress Socks
8. Black Leather Shoes
9. Black Shirt-Stays
10. Soft Shoulder Boards

Optional items authorized for wear with Salt and Peppers include:

Black “Relaxed Fit” Jacket

## **Poly-Cotton Kahkis**

The Poly-Cotton Khaki uniform is the working uniform authorized for wear during Summer Sea Term and is similar to the Poly-Wool Khaki uniform. This uniform consists of the following items:

1. Poly-Cotton Short-Sleeve Khaki Shirt
2. Poly-Cotton Khaki Dress Pants
3. Blue Maritime Ball Cap
4. Nylon Khaki Belt
5. Brass Belt Buckle
6. Plain White Undershirt
7. Black Dress Socks
8. Black Leather Shoes

Optional items authorized for wear with the Poly-Cotton Khakis include:

Black “Relaxed Fit” Jacket

## Miscellaneous Uniform Notes

Brass Belt Buckles: The issued belt buckle has a lacquer coating that protects the belt buckle from tarnish. The lacquer is to be removed by soaking the belt buckle in ammonia. Once the lacquer is removed, the buckle can be polished using Brasso or a similar metal polish. The buckle will need periodic re-polishing and should not be worn with the uniform if it is tarnished. Fourth Class Cadets are not authorized to wear the 24k Gold (“anodized”) brass belt buckles.

Belts: Belts should be cut to size such that the cut end does not extend beyond the underside of the buckle. The cut end of the belt should then be sealed to prevent fraying. This can be done a number of ways, either by burning the end of the belt, coating the end with clear nail polish, or by sewing the end of the belt together using a thread that matches the belt. Belts shall be adjusted in a manner such that only the metal tab is visible from the end of the buckle.

Boiler Suit Sewing: Patches are to be secured to the boiler suit according to the diagram provided. Stitching is to be done neatly in thread that matches the patch being sewn. Machine stitching is the preferred method, although neat hand-stitching is acceptable.

Black Leather Shoes: Leather shoes are to be highly polished at all times while in uniform. There are a number of different methods to polish shoes which can be found on the internet. One of the easiest ways is to use a soft cloth with Kiwi Black “Parade Gloss” Polish and a few drops of water in a buffing motion to obtain a shine. Applying multiple layers of polish will create a mirror-like shine. “Instant Shine” liquids or similar products will deteriorate the leather over time and should not be used to shine your shoes.

Dress Whites Undergarments: Undergarments must be solid white when worn with the Dress Whites, any other colors or patterns will show through the uniform.

Combination Cover: The brim of male covers should be kept dust and fingerprint free, use a soft cloth to buff out any fingerprints. Buttons securing the gold strap shall be rotated to face upwards. The cap device shall be mounted as per the provided diagram, use a marlin spike to make a hole in the mounting band.

Jewelry: Cadets in uniform may not wear conspicuous or garish items of jewelry or adornments, which detract from the uniform. Religious medals may be worn on a neck chain long enough such that the medal is not shown. Other authorized items include watches and Maritime College rings. Only Female cadets may wear earrings. Earrings are limited to a single gold post .25" or less in diameter.

## Manner of Wearing Uniforms

The following is a list of general guidelines to wearing uniforms, more detailed information will come from your IDOs and Squad Leaders in time:

- The prescribed uniform shall be worn at all times in a strictly military manner; jackets and overcoats shall be fully buttoned, and covers shall be worn squarely on the head at all times, under no conditions may uniform shirt sleeves be rolled up.
- Cadets will dress neatly and smartly at all times. Uniforms shall be scrupulously clean.
- All buttons, snaps, zippers, etc. shall be fastened at all times. This includes the "neck button" on all jackets and the boiler suit and pocket buttons.
- Nothing shall be protruding from shirt pockets; all pens and pencils should be stowed completely within. Pants pockets are for stowing necessary items only they should never be overstuffed. The only time a Cadet should put their hands in their pockets is to retrieve an item; if your hands are cold, wear gloves.
- Covers shall be worn squarely on the head with absolutely no backward tilt.
- Articles of clothing shall be legibly marked with the owner's last name, first initial, and class year. Black permanent marker shall be used for light colored clothing and white ink for dark colored clothing. Markings shall be applied neatly with small capital print, preferably on the lower seam of shirts (inside or out) and in the waistband of trousers. Blue-collar PT shirts, white-collar shirts, and boiler suits are to be stenciled with the issued kit ONLY. Freehand labeling of these items looks sloppy and is not uniform.

Uniforms shall be worn according to the following guidelines:

- The uniform of the day: During morning formation; during the academic day; while on watch (except ship watch); when on the Mess deck; when attending MUG Meetings; when attending other official meetings which do not involve work or physical activity.
- Boiler suit: As required while attending lab classes that meet aboard the ship or on the pier area; when on ship watch; when performing Saturday ship work; when on extra duty.
- Maritime issued PT gear: This is optional after 1600. Only issued PT gear is authorized for wear. PT gear may be worn during the day only to a physical education class, the gym, or to the barber.

## Uniform Diagrams

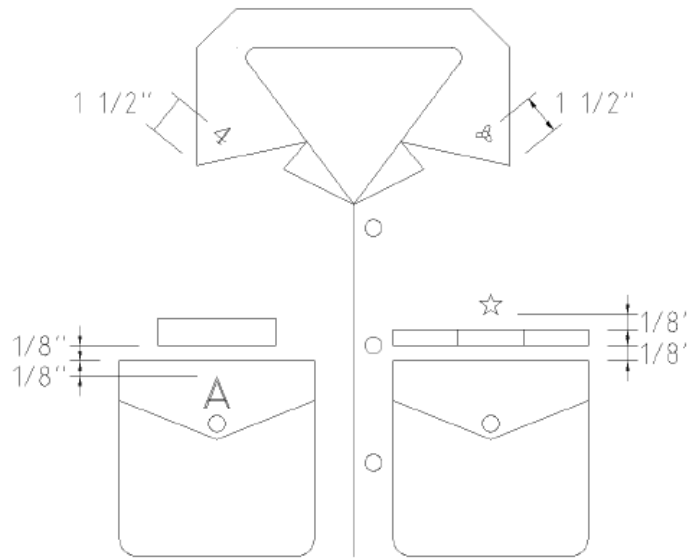

Khakis (Poly-Wool and Poly-Cotton) and Dress Whites (sans collar insignia)

Device is centered on shoulder board

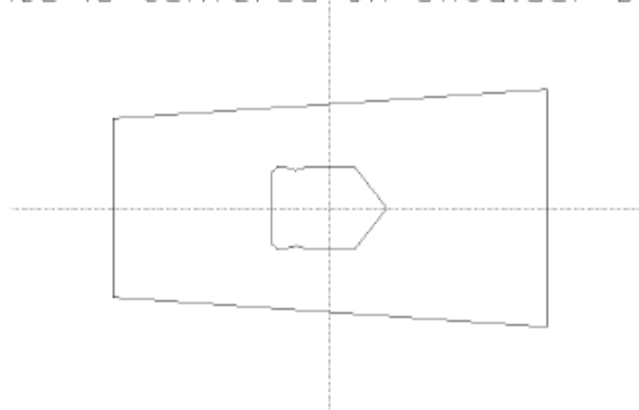

Should Board (point of device towards outboard side of shoulder)



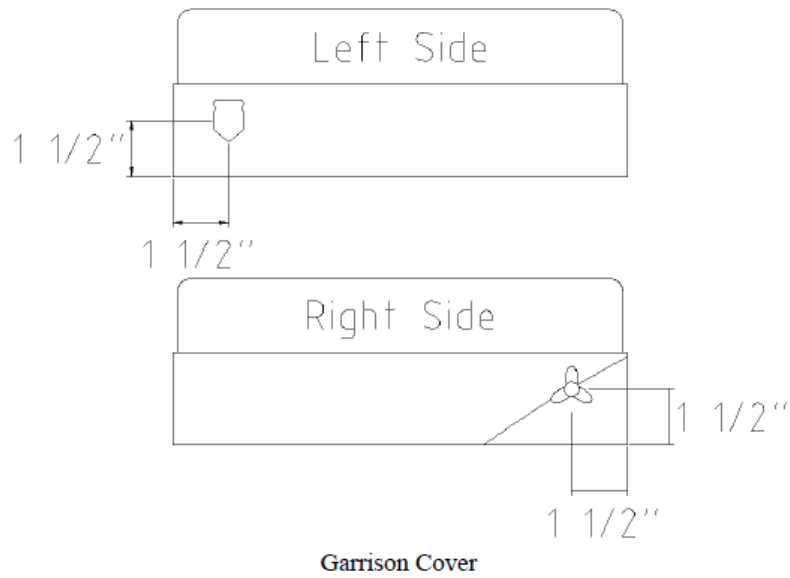

Device is centered with anchor tips touching the mounting band

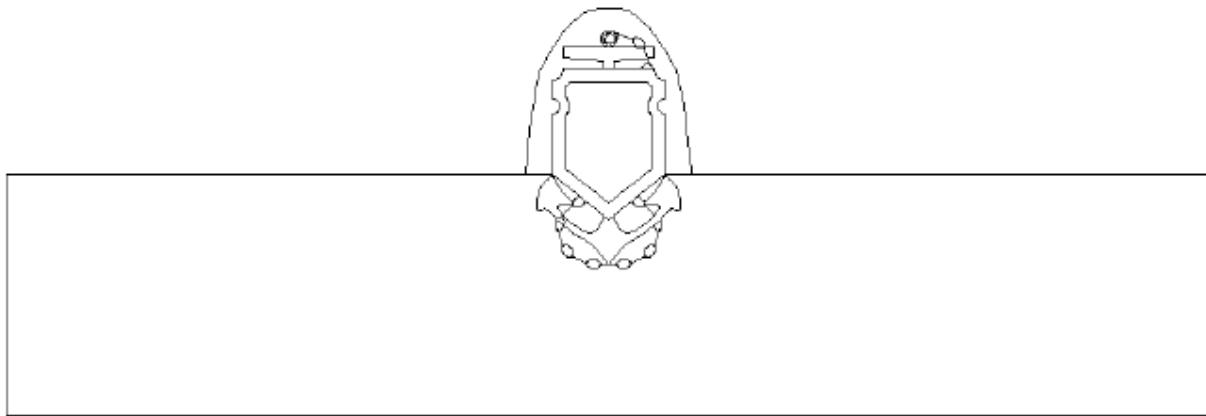

**Combination Cover**



Service Dress Blue- Male

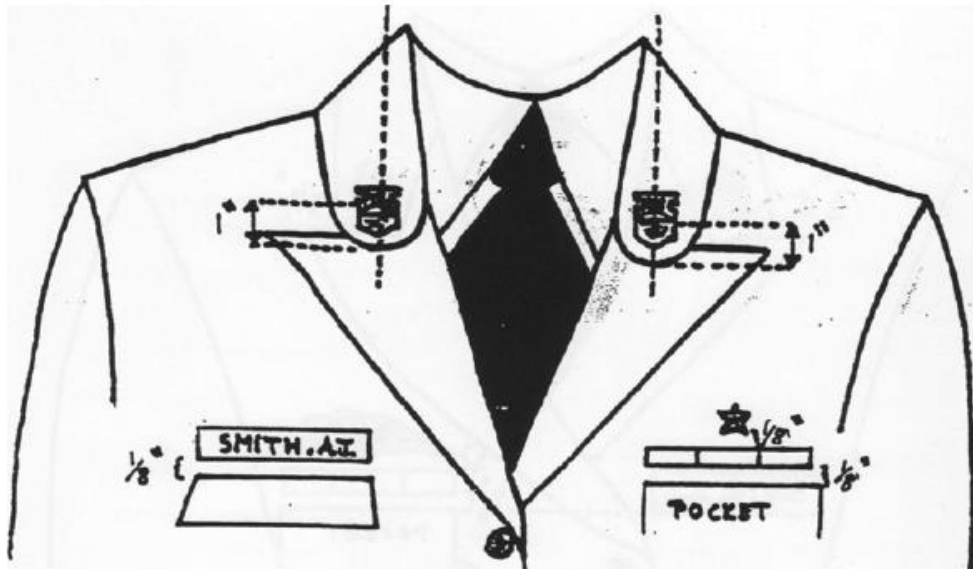

Service Dress Blue- Female

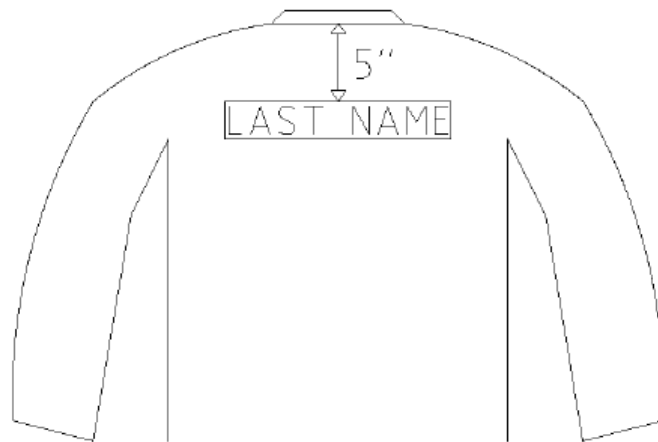
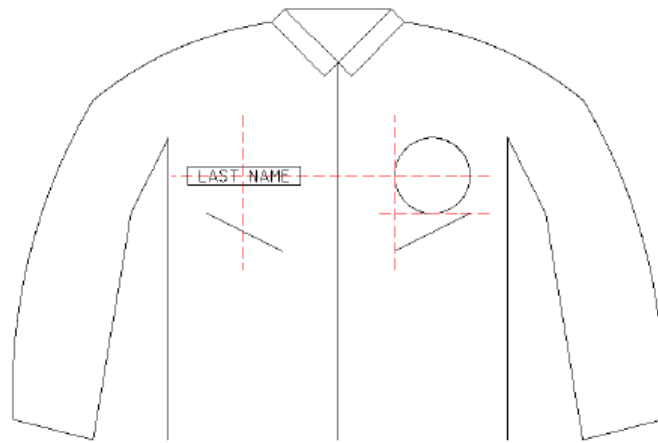

Boiler Suit

## Pocket Rates

While wearing the uniform of the day or the boiler suit, fourth-class cadets shall carry pocket rates on their person at all times. Except as noted, rates are to be carried in a ziploc type plastic bag.

Pocket rates consist of the following items:

- Four quarters
- One pin backing
- Black ink pen
- Mug knife
- Maritime College ID card
- Dormitory room key (on issued lanyard, around neck during Indoc.)
- The *Boatswain's Pipe* (Back right trouser pocket)

While wearing the boiler suit, in addition to the normal pocket rates, the following are also required:

- Blue Bump Cover
- Flashlight
- Eye Protection
- Ear Protection
- Gloves
- TWIC Card (only required if the cadet has a TWIC card and if he/she is going on the training ship)

Pocket rates are not required while wearing a dress uniform, PT uniform, or civilian clothing. Monday through Thursday, when outside during the hours of darkness, and when on watch, a fourth class will carry the issued flashlight.

## MUG Path

The MUG Path is the route taken by MUGs while transiting between buildings on campus and while indoor Regimental Buildings.

The following are the basic "Rules of the Road":

- Square all corners, except when in academic buildings, Reisenberg Hall (Gym), sickbay, and while on the second deck of the Mess deck. Squaring corners will be suspended if there is snow or ice on the deck; this is done as a safety precaution, so do not abuse it.
- Double time in the vicinity of the dormitories, i.e., west of McGowen Street, north of Shepard Avenue, and east of Crowninshield Street. The dotted line outlines this area in the diagram below. Double timing will be suspended if sidewalks are wet, icy, or snowy; again, do not abuse this. To prevent ruining a dress uniform, never double time while wearing one.
- Travel in single file on the inboard side of each sidewalk and walk on the cobblestones between the gym entrance and Marvin-Tode Hall (S&E).
- Do not stop, converse, eat, drink, or use a cell phone along any of these walks.
- Use only the center inboard entrances to the First and Second Battalions of Vander Clute Hall. While in the Battalion Buildings, use only the outboard ladder wells (Furthest from the Quad). Walk on the inboard side of all passageways and square all corners.
- Use only the front entrances to the Mess deck.
- Follow only that route which crosses under the overhang of the Mess deck. Cutting across any part of the Quad is prohibited.
- Enter the Fort only through the Sallyport. After saluting the War Memorial, proceed to the left along the underclass walk. Inside the Fort, use only the spiral ladder wells and the straight ladder just inside the Sallyport leading up to the Humanities Department, classrooms, Personnel Office, and Bursar's Office.
- Gangway and brace near, but not in contact with, the inboard bulkhead whenever an officer or upper-class cadet passes in the dormitory passageway. Although upperclassmen may request fourth-class cadets not to gangway, all fourth classmen are still required to gangway.



# MARITIME COLLEGE STATE UNIVERSITY OF NEW YORK

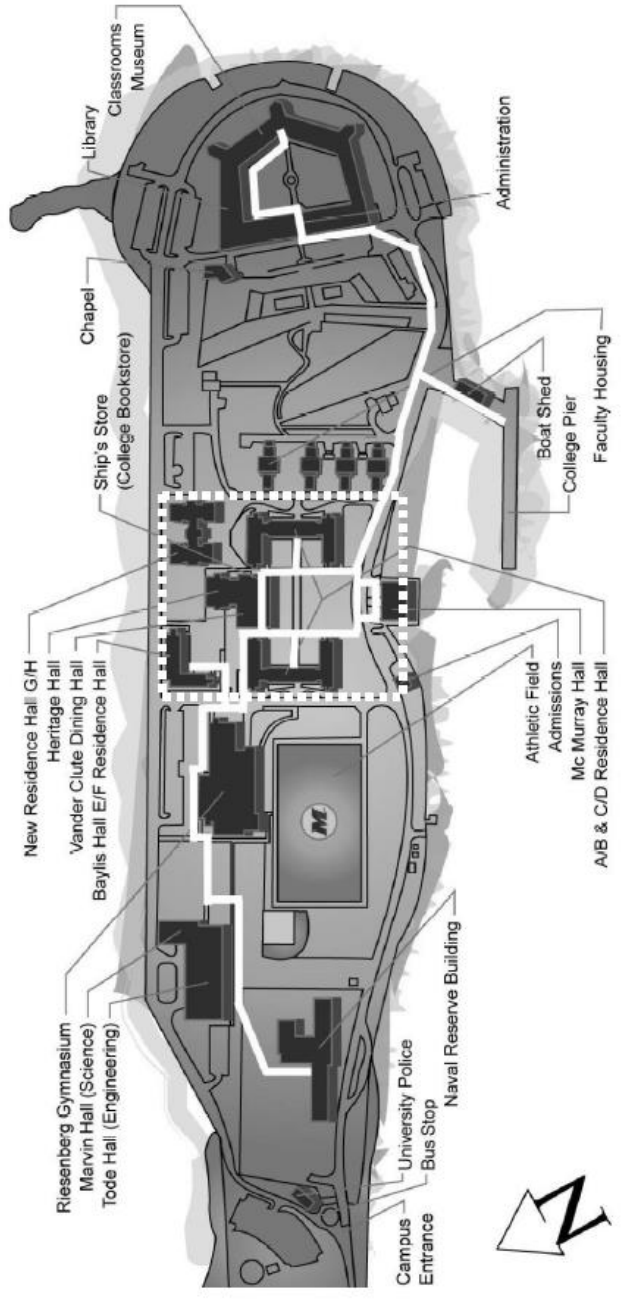

# CAMPUS MAP



# Cadet Quarters

Fourth-Class rooms will be prepared and maintained for inspection in accordance with all policies and procedures listed in the *Boatswain's Pipe* and in the *Rules and Regulations*. Rooms shall be kept in inspection-ready status from 0700 to 2300, Monday through Thursday, and from 0700 to 1600 on Friday. Additionally, rooms shall be prepared for random Health and Safety inspections performed by the Office of Student Housing. Rooms and all furnishings and equipment therein shall be neat, orderly, and thoroughly clean.

If there is a discrepancy between the Office of Student Housing rules ("Guide to Campus Housing"), and those outlined in the *Boatswain's Pipe*, the Office of Student Housing rule supersedes those found in this publication.

## Arrangement of Room Furnishings

Double occupancy rooms are to be arranged according to the diagram and guidelines below:

- Racks and dressers must be pushed as close to the bulkhead as possible without causing damage to paint or electrical plugs.
- Desks will have one side against the bulkhead and chairs will be fully pushed in.
- Dressers will be positioned on opposite sides of the room, against the bulkhead and adjacent to the closets.

If in a triple occupancy room, the room is to be arranged as per the Section Chief IDO.

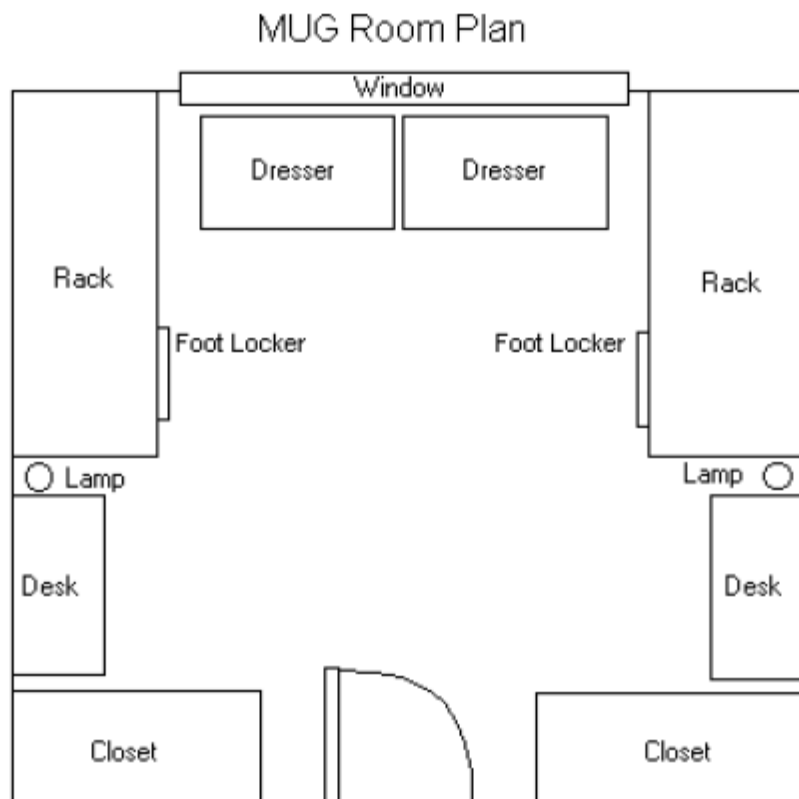

## Racks

Beds are called racks. Racks shall be made in the manner described below, and shall be so maintained from 0700 to 2300 Monday through Thursday and from 0700 to 1600 on Friday. Fourth-class cadets are permitted to sleep above the khaki bedspread during the day. Racks must be immediately returned to inspection-ready status when not in use.

The following guidelines apply to racks:

- The foot locker is stowed under the rack towards the aft end.
- Only plain, unadorned, white sheets and pillowcases are authorized. Sheets must be flat, fitted sheets are not authorized.
- All corners of the bedding shall be arranged in 45-degree angles (hospital corners).
- The top sheet is to be folded over the khaki bedspread so as to form a collar, the width of which shall be six inches. This collar shall be arranged so that twelve inches of the bottom sheet are exposed at the head of the rack. See diagram.
- When not in use, the issued blanket (Spank Blanket) shall be neatly folded at the foot of the rack.
- If required, additional comforters, blankets, or sleeping bags may be used. When not in use, additional bedding is to be folded and stowed neatly on the top shelf of the closet.
- Space underneath the racks is not to be used for storage of personal effects unless directed to do so by your Section Chief IDO.
- The top of the rack is not to be used as a storage place for clothes, or laundry waiting to be folded, the tops of racks shall be clean at all times.

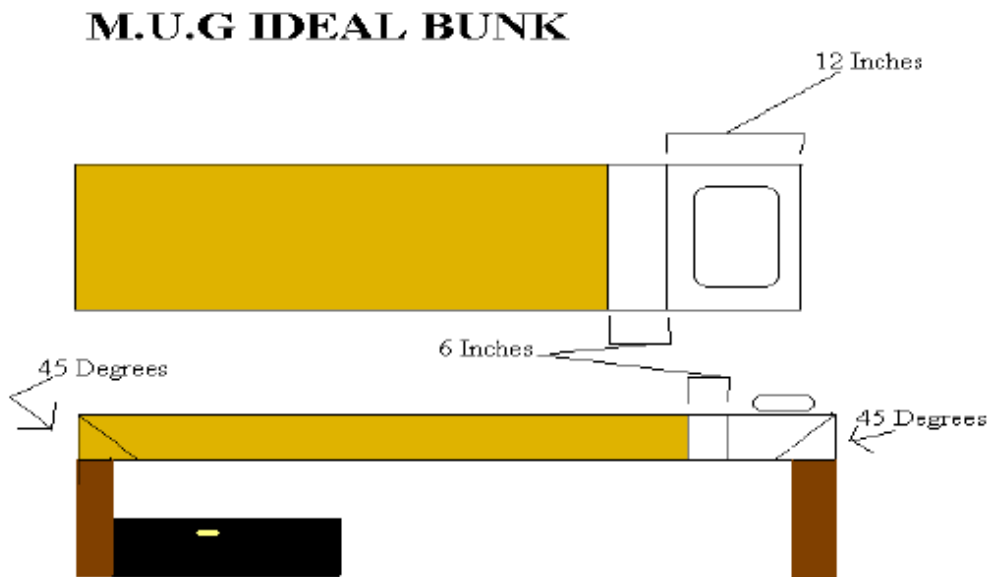

## Clothing and Gear Stowage

The following guidelines cover the stowage of clothing and gear in your room:

- All garments shall be fully buttoned, snapped, tied, fastened, zippered, etc.
- Uniforms not being worn shall immediately be hung on a hanger and put in the closet.
- Uniform articles shall never be hung from the back of your desk chair, thrown on your rack, thrown on the deck, or stuffed into a drawer.
- All shoes and boots shall “toe a line” in the closet, with toes facing outward and with laces fully tied.
- Hangers shall be two finger-widths apart. The space between the inner side of the closet and the first hanger shall be one fist-width.
- The front side of all garments hung in closets shall face in the direction of the door. Closets will thus be symmetrical about the entrance to the room.

- Drawers in desks and dressers shall be tiered for inspection, i.e., the top drawer opened two finger-width; second drawer opened two finger-width beyond the top drawer, continuing for all drawers.
- All clothing stowed in the third and fourth drawers of the dresser shall be rolled.
- Boiler suits and blue work jackets shall be stenciled on the outside, in two-inch tall white block lettering. The top edge of the letters shall be five inches below the bottom edge of the neckband; letters will be centered horizontally. See boiler suit diagram. When soiled, boiler suits must be washed before being returned to the dresser.
- Towels will be folded neatly and hung from the towel racks (if authorized).
- All linens shall be washed regularly and kept white. Laundry shall accumulate for no longer than one week.

## Closet Stowage

As you face your closet, the following items are to be hung in succession, starting from the side closest to the door:

- |                                |  |
|--------------------------------|--|
| 1. Poly-Wool Khaki Uniform     | -Long-sleeve white shirt   |
| 2. In-Season Dress Uniform     | 3. Poly-Cotton Khaki Uniform   |
| -Summer (Whites) Dress Uniform | 4. Out-of-Season Dress Uniform                                       |
| -Winter (SDB) Dress Uniform    | 5. Black Sweater   |
| 6. Black "Relaxed Fit" Jacket  | 10. Civilian Clothing (pushed off to outboard side)                  |
| 7. Pea Coat                    | 11. Sea Bag, hung by strap, buckle facing inboard to the passageway. |
| 8. Black Work Jacket           |  |
| 9. Issued Sweat Suit           |  |

Items to be stowed on the lower closet shelf, starting with side closest to the door:

- |  |  |
|--|--|
| 1. Combination Cover, kept in plastic bag  | 5. Work Gloves, under bump cover           |
| 2. Black Leather Gloves, under dress cover | 6. Shower Kit                              |
| 3. Garrison Cap                            | 7. Additional Toiletries, organized neatly |
| 4. Blue Bump Cover                         |  |

Items on the upper closet shelf:

1. Telephone connections (if applicable)
2. Stencil kit and shoe shine items
3. Issued Maritime College ball cap
4. Extra sheets, pillow cases, towels
5. Extra blankets, sleeping bag
6. Extra books
7. Miscellaneous items not specified above

Items in the front row of the closet deck:

- |                              |                            |
|------------------------------|----------------------------|
| 1. In-Season Dress Shoes     | 5. Casual and shower shoes |
| 2. Out-Of-Season Dress Shoes | 6. Laundry bag, in corner  |
| 3. Black Leather Dress Shoes |                            |
| 4. Sneakers                  |                            |

Items in the back row of the closet deck:

- |   |                                  |
|---|----------------------------------|
| 1. Work boots   | 3. Brass polish                  |
| 2. Bucket, with cleaning supplies, rags, and sponges inside | 4. Brooms, swabs, dustpans, etc. |
|   | 5. Sports equipment, in corner   |



## **Dresser Stowage**

Items in top dresser drawer:

1. Small personal items
2. Belts and tie
3. Shoulder Boards
4. Uniform Insignia
5. Scarf

Items in second dresser drawer:

1. Boiler suit
2. Black watch cap
3. Other work clothes and items (tools, MUG light, etc.)

Items in third dresser drawer: (rolled)

1. White T-shirts
2. Underwear
3. Socks

Items in fourth dresser drawer: (rolled)

1. Issued PT shorts
2. Issued PT shirt
3. Issued swimsuit
4. Thermal underwear
5. Non-issued athletic clothing

Items in fifth dresser drawer:

1. Civilian clothing, other than that covered above

All complete uniforms should be hung on the same hanger, for example, khaki shirt and trousers, SDB Jacket and SDB trousers, sweatshirt and sweatpants, etc.

Any articles not identified in this section shall be stowed in accordance with each deck's established policies. These policies may vary slightly from deck to deck, but rooms on the same deck shall be uniform.

## **Computers**

Personal computers are authorized after the Indoctrination Period. Requirements for computer set-up may vary. The IDO's on deck will approve your particular set-up. Whatever the installation, power cords will be neatly arranged and the equipment shall be kept clean. Cadets will not use computer programs such as audio-stations, television cards, DVD players, video games, etc., which replicate equipment not otherwise authorized for their respective class.

## **Posters and Wall Hangings**

No wall hangings are authorized during the Indoctrination Period. Following completion of the Indoctrination Period and upon authorization, each room will be allowed two posters/wall hangings not to exceed 3 x 4 feet each. Each room may then also affix one official school calendar to the wooden frame around the window.

All posters/wall hangings shall be in good taste. No nudity, vulgarity, explicit sexuality, or offensive material of any type will be tolerated. No decorations depicting or promoting alcohol are permitted. Any flags or items that may be offensive to others will not be permitted.

## **Stereo and Sound Equipment**

Until authorized, the use of stereo or sound equipment (iPods, computer speakers, etc.) is prohibited. Any such equipment found in a cadet's room is considered contraband.

The Regimental Commander in association with the Chief Indoctrination Officer will grant the use of stereo/sound equipment privileges. Stereo/sound equipment must conform to applicable housing or regimental policies and regulations.

Music playing, regardless of the above statement, is prohibited during study hours and after taps. Stereo/sound equipment will be played only at a reasonable level so that the sound remains within the room. Be considerate if your roommate is studying, sleeping, or otherwise occupied.

## **Room Visitation**

Fourth class shall enter upper-class rooms for official reasons only. If studying with an upper-class cadet, do so in a study lounge or in the Library. Loitering in upper-class rooms at any time is a violation of fourth-class privileges.

Except for official purposes, i.e., room inspections, upper-class cadets will not loiter in fourth-class rooms.

## **Bulletin Boards**

The information posted on bulletin boards concerns all hands. You will be responsible for reading all information posted thereon daily. The most important bulletin boards are the "T-Boards" at the "T" intersection of each deck in the company buildings. These bulletin boards will contain information such as watch bills, the plan of the week, and any other special pertinent information. Make it a habit of checking the board as you walk by.

## **Shower**

Mugs will proceed to and from the showers in the prescribed PT gear. Mugs will NOT travel to or from the showers with just a "towel wrap" or bathrobe.

## **Laundry**

When using the company's laundry facilities, consideration should be shown for other Cadets. If the washer to be used is full, advance the load therein to a dryer. If the dryer to be used is full, the load therein (if completely dry) should be removed and neatly placed on top of the dryer. Everyone is responsible for his or her own laundry. Never throw someone else's clean laundry on the floor or into dirt or water.

Make it a habit of cleaning the lint trap after you have used the dryer and throwing it in a trash can. The number one source of shipboard fires is dirty lint traps.

# MUG Responsibilities

## Regimental Watch Standing

The seagoing profession, which operates on a continuous basis, is organized on the “watch” system to ensure the safety and proper operation of the ship; thus, the Regiment of Cadets is likewise organized on a structured watch system that operates on a continuous basis. Proper watch standing is an essential element of the maritime profession.

In order to develop the proper sense of watch responsibilities, and to ensure the safety of the campus facilities and the training ship, all cadets participate in the watch system according to their level of experience and professional development.

Fourth class cadets will report to the watch station thirty minutes before the top of the hour. (e.g., arrive prior to 2330 for the 0000-0400 watch) While going to and from watch, all fourth class rules are to be followed. After reporting to, and while standing watch, fourth classmen are not required to double time or square corners and may use the most direct route. Cadets shall wear a cover and carry a flashlight when on a round.

Cadets reporting for watch shall first read the Standing Orders for that particular watch station. Being familiar with the Standing Orders is the first step towards understanding how to stand a proper and vigilant watch. A round is the visual inspection of a place or area in the Regiment.

Rounds are made at the direction of the Cadet Watch Officer (CWO) ashore, and the Cadet Quartermaster (QM) aboard the ship. The following guidelines apply to rounds:

- Rounds are to be conducted three (3) or four (4) times throughout a watch or at the discretion of the upperclass on watch to insure that quiet/study hours are being observed and to note/report any property damage, fires, floods, etc.
- Inspect all firefighting equipment, including extinguishers, hoses, pull boxes and fire bells during rounds and report all deficiencies.
- Aboard ship it will consist of a “Detex” round and is covered in more detail in other publications.

## Log Procedures

The College follows the Navy's guidelines for properly keeping a ship's log for all watchstations, whether on ship or on land. This guideline is OPNAVINST 3100.7B, but is modified for appropriate application to the regiment and a merchant vessel. Some of the key aspects of this instruction that apply are:

- Record all events of the day. Use succeeding lines when necessary to describe events. This includes (but is not limited to) rounds taken and results of the round, drafts read, accidents of any type or kind, unusual events, and special orders passed down from higher authorities or from previous watches.
- All logs will be filled out in CAPITAL letters in neat, block-letter style handwriting
- When a correction is considered necessary, draw a single line through the original entry so that the entry remains legible. Insert the correct entry to ensure clarity and legibility. Once a correction has been made, the person making the correction will put their initials in the lefthand margin of the page
- Occasionally, information may be received after events have already been recorded. In this case, make a "late entry" as follows: In the left-hand margin corresponding to where the entry should have been recorded, place an asterisk "\*". Enter the "late entry" on the next available line and put another asterisk in the left-hand margin. Example:

0745	4/C RETURNS FROM ROUND, ALL IS IN APPARENT GOOD ORDER*
0801	AMBULANCE ARRIVES ON CAMPUS TRYING TO FIND CADET DOE, 4/C
*0750	CADET DOE, 4/C FALLS DOWN STAIRS IN B COMPANY, BREAKS LEG
0820	AMBULANCE LEAVES WITH CADET DOE TO CALVARY HOSPITAL FOR TREATMENT

## Reporting a Fire

All cadets should take prompt action when a fire is detected. Anyone discovering a fire should immediately activate the nearest fire alarm pull box. If the fire is in an area not equipped with a pull box, that person should inform Public Safety at extension 7310.

## Fire Alarms

If the dormitory fire alarm sounds, evacuate the building via the most direct route. Follow the procedure as established by the IDOs on deck.

The deliberate setting of false alarms will not be tolerated. Fire pull boxes are furnished as lifesaving devices. Intentional misuse is a criminal offense.

## Typical Day for the Fourth Class

0630	Reveille
0615 – 0720	Breakfast
0720 – 0740	Morning Formation
0740 – 0750	Morning Room Inspection
0800 – 1615	Classes
1115 – 1300	Lunch
1615 – 1900	Sports or Free Time
1700 – 2000	Dinner
1900 – 2200	MUG Meetings or Deck/Engine Training; not held every night
1900 – 2200	Mandatory Study Hours.
2200 – 2230	Cleaning Stations
2230 – 2300	Taps
2300	Lights Out

Note: Exact times can change from year to year, pay attention to updated times from your IDOs and Squad Leaders.

## Dormitory Study Hours and Accountability

To provide a quiet atmosphere for studying, mandatory study hours are enforced on all decks from 1900 to 2200 Monday through Thursday. During study hours, fourth class are to be studying in their rooms, in company study rooms, the library, or the learning center. Doors to your room are to be open during this time. In the interest of accountability, fourth class cadets must sign out using the sign out sheet before leaving the deck. It is imperative that you develop good study habits and learn to manage your time wisely.

## Deck or Engine Training

Typically once per week throughout the academic year, deck and engine license cadets are required to attend Deck or Engine Training. During this time, you will be given training and information that helps you prepare for your first Summer Sea Term.

The CDIDO and CEIDO are in charge of the training programs with help from the CDSL and CESL. It is essential that you be present at every training session. More information will be given at the end of Indoc or within the first few weeks of class.

## Cleaning Stations and Taps

At 2200 every Monday through Thursday, "Cleaning Stations" commences with the deck captain calling "Cleaning Stations". Fourth-class cadets on watch will not be present. Those scheduled for 0000-0400 and 0400-0800 watches the following morning will be granted sleep-in through cleaning stations and taps. A note posted on the cadet's door shall make these situations known.

Fourth class will be assigned cleaning stations and be designated responsibilities in keeping their passageways, heads, and showers clean and free of litter. These “deck chores” also include keeping the deck bright work (brass) polished. It is particularly important to maintain clean living quarters on weekends. Treat college property as if it were your own.

One fourth-class cadet on each deck will be designated a deck captain, on a rotating basis. This is a chance to gain some valuable leadership experience and tactfully manage deck activities such as directing deck chores. Cleaning stations inspections will occur periodically throughout the semester to assess the level of cleanliness and can be random; inspectors are typically Chief IDOs or rates.

After cleaning station, taps are held in which the Section Chief IDO and his staff may do numerous activities with your deck; typically this includes going over tomorrow's POD or holding a discussion on pertinent campus events. Taps typically does not run later than 2300.

## **Physical Training**

Physical fitness is a crucial element of life at sea and should be a part of every sailor's life. Sailors who choose not to maintain a state of good physical fitness place themselves and their shipmates at risk, especially in emergency situations.

The principal goal of the Fourth Class Physical Training (PT) Program is to create a culture of fitness and promote good lifelong physical fitness habits. PT is integrated into a number of evolutions each Fourth Class Cadet participates in to further these objectives.

During Indoctrination, Fourth Class Cadets will be required to PT daily. This daily PT is designed to assist in preparing the class for the Physical Readiness Test (PRT), which is held at the end of the indoctrination period. The PRT determines a Fourth Class Cadet's level of participation in weekly PT throughout their MUG year. Participation in PT during the academic year will range from one (1) to three (3) times per week, depending on your individual PRT score. "Remedial PT" is the term used to describe the two (2) extra PT sessions per week held on Monday and Wednesday mornings. Remedial is assigned to cadets who do not achieve the minimum standards of the PRT. PRTs will be held throughout the year to ensure each Fourth Class Cadet is maintaining an acceptable level of physical fitness and to allow Cadets to test out of Remedial PT.

The PRT consist of three scored events: push-ups, sit-ups (also known as curl-ups), and a 1.5 mile timed run. The events are given in one session, a cadet must complete all three events in order to pass. The traditional standard for the PRT for men and women in the age group 17-19 is a "Good Low". The scoring will be calculated and a final score will be given as per the Chief PT IDO. This standard will be subject to change upon class performance and to enhance physical fitness objectives.

Male:

Curl-Ups: 62 Push-Ups: 51 1.5 Mile Run: 11:00

Female:

Curl-Ups: 62 Push-Ups: 24 1.5 Mile Run: 13:30

The Commandant of Cadets has the ability to appoint a Regimental PT Rate whose responsibility is to organize and execute Regimental Physical Training exercises. This position, as well as the responsibilities, are also subject to the needs of the school at the beginning of a new semester.

## **Extracurricular Activities**

There are numerous extracurricular activities offered at the Maritime College. Information about these activities are typically provided during the first or second week of classes. Club announcements and meeting times are usually posted on dormitory bulletin boards. Cadets are encouraged to join clubs and sports teams of interest to them. However, the fourth classmen are cautioned to not overly commit themselves, as free time is limited during the freshman year. Pursuit of academic success should be the highest priority.

# The Commercial Maritime Industry-“Our Business”

## U.S. Maritime Policy

- Admiralty is the body of laws which govern the business of carrying cargo and passengers over water.
- The Merchant Marine Act of 1936 allowed government provision for, among other things:
  - Provided for government support of a U.S. Flagged Merchant Marine.
  - Subsidized the U.S. construction of merchant ships. The Liberty ships of World War II, built under this act, were turned out at a rate of one per week.
- The Jones Act supports the U.S. Merchant Marine domestic water-borne commerce by mandating domestic trade to be done by U.S. flagged, built, and operated ships.
- A strong U.S. Merchant Marine supports the *economic security, defense security, and environmental concerns* of the United States.
- Cargo Preference Laws are laws which give government cargo preference over commercial cargo on those vessels which receive ODS subsidies.
- MARPOL of 1970 outlaws discharge of oily waste within 50 miles of any land or specified zones, such as the Mediterranean Sea.
- The Oil Pollution Act of 1990 was brought about by the Exxon Valdez marine casualty. The super tanker Exxon Valdez ran aground on Bligh Reef in Prince William Sound, Alaska. The accident was the largest to ever occur in U.S. waters before the *Deepwater Horizon* incident of 2010. OPA 90 now requires tankers to be double hulled, seamen to have 6 hours of rest for every 12 hours aboard, spill contingency plans, and prohibits the consumption of alcohol within 12 hours of a cargo watch or ship sailing.
- TEZ (Tanker Exclusion Zones) are areas where transiting tank ships are not permitted to cross unless the port of destination lies within that zone.
- The U.S. ranks 26<sup>th</sup> in the world's merchant fleet in number of ships under registry. The 2010 figures list the U.S. with 418 ships in its registry.
- The majority of the U.S. flagged merchant fleet is made up of container ships  
Foreign flagged ships carry 80% of U.S. waterborne imports and exports.
- The U.S. Merchant Marine and Maritime College Cadets have been involved in every U.S. armed conflict since World War II. Operation Desert Shield and Desert Storm, involving over 150 cadets, 95% of all U.S. equipment for Operation Desert Storm was carried on U.S. flagged commercial ships.
- The Panamanian Flag is the most common flag of registry for the world's commercial fleet.
- The cost of operating under U.S. registry is 6 times greater than operating under a foreign registry.
- In 1960 the United States had 100,000 active seafarers, since then that number has dropped to 77,500 in 2008.

## Types of Vessels

There are a large number of different types of merchant vessels plying the seas today. During your first cruise, you will come in contact with most, if not all, of these types. For your familiarization, the major categories are listed below.

### Break Bulk

The general day cargo carrier, or break bulk, is the "classic" cargo carrying ship. Virtually any, nonliquid cargo, whether packaged or in bulk, can be carried in the main cargo holds of this type of ship. In addition, most also have deep tanks for carrying small amounts of liquid cargo. Some also have special holds designed to carry refrigerated cargo. There are even some "heavy lift" ships, fitted with such equipment as extra ballast spaces and heavy lift cargo gear, designed for carrying such extremely heavy equipment as railway locomotives, tanks, and power plant generators. Break bulk is by far the most versatile breed of ship in use. They also use their own cargo gear to load and discharge cargo, and need no special equipment ashore. Their chief disadvantage is their slow and inefficient cargo handling; because of this, the break bulk is slowly losing ground to more efficient ships.

## **Container Ships**

The container ship is the answer to the problems of slow cargo handling and long turnaround times common with the break bulk ship. Standard shipping containers, either 8'x8'x40' or 8'x8'x20', are used to encase parcels of cargo. These containers (or just plain "boxes") are designed to fit directly on the back of a truck trailer. Huge shore side cranes are used to transfer the containers from the ship to the waiting trucks below. These ships are ideally designed for high volume, high-speed transport. They are without question the most efficient cargo ships in use today.

## **LASH Vessel**

The LASH, or Lighter Aboard Ship, was an attempt to take the container concept one step further. This ship was designed to be able to lighter, or take on cargo without docking. Tugboats would transport barges filled with cargo to the anchored ship

## **Bulk Carriers**

A bulk carrier, as contrasted with a break bulk ship, is designed exclusively for carrying bulk commodities such as grain or ore. An example of this type of ship would be the Great Lakes iron ore carrier. A subclass of this type of ship is the Oil-Bulk-Ore carrier (OBO carrier). This ship is designed to carry a bulk commodity on one leg of a voyage, and to carry oil (or other bulk commodity) on the return trip.

## **Tankers**

There are many types of tank vessels. The "supertankers", Very Large Crude Carriers (VLCCs) and Ultra-Large Crude Carriers (ULCCs), are the most popularly known. Smaller, but no less important, are the coastal "handy" size tankers which are designed to carry refined products. There are also the heavily subdivided "drugstore" tankers, designed for a large number of different petrochemical types. A major sub-type of tanker is the Liquefied Natural Gas (LNG) tanker. This type of vessel uses specially insulated storage tanks to keep the liquid at a cryogenic temperature. The ship is powered by the gas vapors evaporating off of the LNG.

## **RO-RO**

The Roll-On Roll-Off (RO-RO) is a ship specially designed for carrying vehicles. A stem ramp and/or side ramps are used to provide a direct drive into the cargo holds of the ship. Once in the hold, lashings are used to secure the vehicles in place for the voyage. RO-RO's can be either dedicated totally to vehicle transportation, or can also have facilities to handle containers or other cargo.

## **Integrated Tug and Barge**

This recent innovation allows tugboats to be actively used for coastal cargo transportation. The barge is designed with a notch on the centerline large enough to fit the bow of the tug. When needed, the tug will fit into the notch, and then extend a locking bar into sockets in the barge frame. The tug and barge are then locked into one single, composite unit. Fast turn around time is an advantage to this system. They are not as seaworthy as normal ships however, and are therefore mostly used in the coastwise trade.

## **Sailing Vessels**

- Sloop: A single masted, fore-and-aft rigged vessel that usually carries a forward staysail and one or more jibs. May be "cutter-rigged" with more than one staysail and is commonly used for yachting and racing.
- Cutter: A single masted, fore-and-aft rigged vessel with two or three headsails and a gaff-topsail. Has a deeper draft than a sloop. The term is also used for US Coast Guard vessels.
- Schooner: A vessel with two or more masts where the after mast is not shorter than the foremast(s). It is principally fore-and-aft rigged, but may have a gaff-topsail, a square topsail and/or a topgallant sail. Originating in Gloucester, it was a principal workhorse in the fishing and coastal cargo trades of the United States.

Brig: A two-masted, square rigged vessel having a fore-and-aft mainsail on the mainmast.  
Brigantine: A two-masted vessel square rigged on the foremast and fore-and-aft rigged (schooner rigged) on the mainmast.  
Ship: A vessel with three or more masts, all square rigged.  
Bark: A vessel with three or masts, square rigged, with the aftermost fore-and-aft rigged  
Barkentine: A vessel with three or more masts, the foremast square rigged and all other masts fore-and-aft rigged

## Notable American Merchant Ships

### *Clermont*

*Clermont* being a misnomer, the *North River Steam Boat* was built in New York for service on the Hudson River between New York City and Albany. She was 130 feet long and was propelled by a 24 horsepower Boulton and Watt steam engine connected to two paddle wheels.

The first voyage from New York City to Albany (150 miles) took two days, including a 20 hour stopover at Robert Livingston's estate. The average speed for the voyage was 5 miles per hour. Robert Fulton and his partner Robert Livingston began regular steamboat service in 1807 and eventually expanded to three boats.

Although not the first steamboat built or successfully tested, the *Clermont* is the first commercially successful steamboat.

### *SS United States*

Keel laid on 08 February 1950, launched and named on 23 February 1951 at Newport News Shipbuilding and Dry-dock Company (the same shipyard which built the *TS Empire State*). The ship was built to Navy standards in order to be converted to a troop ship capable of carrying 14,000 troops during times of war. Owned by the United States Lines, she is 990 feet in length, 53,000 gross tons, and was the Blue Ribband Trophy holder for eastbound and westbound trans-Atlantic crossings. The westbound record is still unbroken.

Eastbound Passage 03 July 1952:

Ambrose Lightship (NY) to Bishop Rock (England): 2,942 nautical miles in 3 days, 10 hours, and 40 minutes. Average speed: 35.59 knots.

The ship enjoyed a successful 17-year career before declining revenue (due to the introduction of jet airplane service between the United States and Europe) forced the ship into Reserve Fleet in 1969.

Every permanent Master of the *SS United States* was an alumnus of the Maritime College. Her last Master was Commodore Leroy J. Alexanderson, Class of '30. The ship is currently berthed at a pier in Philadelphia, PA with an uncertain future.

### *NS Savannah*

The first and only nuclear powered merchant vessel under US Flag. It was launched in 1959 as a joint project of the former Atomic Energy Commission (AEC) and the Maritime Administration (then part of the U.S. Department of Commerce). Among its primary purposes were to demonstrate the peaceful uses of atomic power; to demonstrate the feasibility of nuclear-powered merchant ships; and to develop the maritime infrastructure (e.g., liability and insurance, port security and emergency response, shipyard maintenance and repair, etc.) necessary for subsequent nuclear-powered merchant ships. It accomplished these objectives, and all others that were laid out for it, very satisfactorily.

The ship remained in experimental cargo service until 1970, when its nuclear fuel was removed. Currently, the ship is docked under a long-term laybirth contract in Baltimore, MD.

## Ship's Measurement Using Tonnage

Thirteenth century merchant vessels carried wine in 250 gallon wooden barrels called *tuns* which when full, occupied 57 cubic feet of space and weighed 2,240 pounds. This capacity and weight for a *tun* was established British law in the fifteenth century. Port taxes at the time were paid in actual barrels or *tuns* and this payment came to be known as *tonnage*.



## Gross Tonnage/Gross Registered Tonnage (GRT)

The total internal cubic volume of a vessel divided by 100; e.g. 150,000 cubic feet / 100 = 15,000 Gross Tons. It is important to remember Gross Tonnage is a measurement of *cubic capacity*, *not weight*.

## Net Tonnage (NT)

The gross tonnage of a vessel, minus exempted non-revenue earning spaces. This is a measure of a ship's earning capacity and is also used as a basis for taxes, lighthouse dues, wharfage, pilotage, and canal / lock fees.

## Deadweight Tonnage (DWT)

The total amount of weight a ship can carry including cargo, bunkers, stores, spare parts, passengers, crew, and their effects.

## Displacement

The total weight of a ship afloat is equal to the weight of the water displaced. This is expressed in cubic feet of water or long tons

1 cubic foot of seawater: 64 lbs.

1 cubic foot of fresh water: 62.5 lbs.

1 long ton: 2,240 lbs. 35 cubic ft of seawater 35.9 cubic feet of fresh water

## Diesel Engines

Diesel Engines are the most common main propulsion engine found on modern merchant ships and can be broken down into two (2) major categories, four stroke and two stroke. In a four stroke engine, four (4) strokes of the piston are required to complete one cycle; this consists of the intake, compression, expansion, and exhaust strokes. A two stroke engine completes a cycle every two (2) strokes with every down stroke being a power stroke. Intake, combustion, and exhaust are combined in a single stroke, the remaining stroke is compression.

The following are terms that apply to diesel engine:

Bore:	The diameter of an engine cylinder
Piston:	Cylindrical part connected to the connecting rod by the piston pin. The force of the exploding fuel against the closed end of the piston forces the piston down in the cylinder causing the connecting rod to rotate the crankshaft
Cylinder:	A round hole in which the piston reciprocates. Also known as the engine bore
Cylinder Head:	A detachable portion of an engine which covers the upper end of the cylinder bores and includes the combustion chamber and, in the case of overhead valve engines, also includes the valves
Crankshaft:	The main shaft of an engine, which, together with the connecting rods, changes the reciprocating motion of the pistons to a rotary motion
Fuel Injector:	A device used for injecting fuel oil into the combustion chamber of an engine against the pressure of air within the chamber
Top Dead Center:	The position of a vertical reciprocating piston at its uppermost point of travel
Bottom Dead Center:	The position of a vertical reciprocating piston at its lowest point of travel.
Governor:	A device designed to control the speed of an engine within specified limits.
Turbocharger:	Takes the exhaust gas from the engine to run a turbine and impeller on a common shaft to increase the flow of scavenging air.
Crosshead:	Located between the piston rod and the connecting rod, the crosshead transmits the motion from the piston rod to the connecting rod, this is in turn connected to the crankshaft. The crosshead takes the side thrust usually taken by the piston

Piston Rod:	In a crosshead engine, connects the piston itself with the crosshead bearing and has a straight reciprocating motion.
Connecting Rod:	The connecting link between the piston and the crankshaft
Camshaft:	Shaft containing lobes or cams, which operate engine valves.
Slow Speed Diesel:	Engines whose crankshaft speeds are a suitable match for direct connection to a ship's propeller without reduction gearing, and so tend to have crankshaft speeds below 300 RPM.
Medium Speed Diesel:	Engines whose speeds range from 300 RPM to 1200 RPM and require reduction gearing to drive the ship's propeller at a suitable speed.
High Speed Diesel:	Engines whose speeds are in excess of 1200 RPM and require reduction gearing to drive the ship's propeller at a suitable speed.
"V" Type Engine:	The pistons are tilted at an angle to alternating sides of the engine
In-Line Type Engine:	All of the pistons are in a straight line with each other
Port Scavenging:	Exhaust gas and scavenging air enter and exit through ports in the cylinder lining opened when the piston is near BDC
Valve Scavenging:	A type of engine where the exhaust gases are expelled through valves in the cylinder head
Heavy Fuel Oil (HFO):	Also called Bunker C, the crude fuel oil used in most marine diesel propulsion plants because of its low cost
Marine Diesel Oil (MDO):	It has a lower ignition point, burns cleaner, and is lighter than HFO. It is also interchangeable with HFO in marine diesel plants
British Thermal Unit (BTU):	The quantity of heat needed to raise the temperature of one pound of water 1°F

## Steam Engines

### Boiler Types:

Drum or Bent Tube:	This boiler has a steam drum and mud/water drum connected by bent tubes. Also called a D-Type, it is an accelerated type, natural circulation boiler. The advantage of this type of boiler is the reduction in weight and space requirements. The drum-type is the better-suited boiler for the high-powered Merchant Marine and Navy applications.
Sectional Header:	A horizontal boiler in which tubes are assembled in sections into front and rear headers; the latter, in turn, are connected to the boiler drum by vertical tubes. Advantages of the <i>sectional</i> header type of boiler is that there are only a few straight tubes, which means fewer parts, so it is less expensive to maintain. It is also easy to make adequate checks on these types of boiler.

### Superheater Types:

Convection:	Heated by convection from the furnace gases passing over them
Separately Fired:	Heated by a separate furnace, used for that sole purpose
Desuperheater:	Cool water absorbs heat from superheated steam as it passes through the coils of the desuperheater. Used when saturated or only slightly superheated steam is required for auxiliaries.
Radiant:	Heated by flame, hot brickwork, or the fuel bed.

### Condenser Types:

Jet or Barometric Surface:	Steam and cooling water are directly mixed Cooling water passes through, tubes around which exhaust steam is directed. The transfer of heat from the steam to the water, taking place through the tube wall, condenses the steam. As the exhaust steam condenses to water, it is collected and drained off by a condensate pump.
----------------------------	---

## Phonetic Alphabet

A – Alpha  
 B - Bravo  
 C - Charlie  
 D - Delta  
 E - Echo  
 F - Foxtrot  
 G - Golf  
 H - Hotel  
 I - India  
 J – Juliet  
 K – Kilo  
 L - Lima  
 M - Mike

N - November  
 O - Oscar  
 P - Papa  
 Q - Quebec  
 R - Romeo  
 S - Sierra  
 T - Tango  
 U - Uniform  
 V - Victor  
 W - Whiskey  
 X - X-Ray  
 Y - Yankee  
 Z – Zulu

## Morse Code

A	-	• –	N	-	– •	0	-	– – – – –
B	-	– • • •	O	-	– – – –	1	-	• – – – –
C	-	– • – •	P	-	• – – •	2	-	• • – – –
D	-	– • •	Q	-	– – • –	3	-	• • • – –
E	-	•	R	-	• – •	4	-	• • • • –
F	-	• • – •	S	-	• • •	5	-	• • • • •
G	-	– – •	T	-	–	6	-	– • • • •
H	-	• • • •	U	-	• • –	7	-	– – • • •
I	-	• •	V	-	• • • –	8	-	– – – • •
J	-	• – – –	W	-	• – –	9	-	– – – – •
K	-	– • –	X	-	– • • –			
L	-	• – • •	Y	-	– • – –			
M	-	– –	Z	-	– – • •			

## Distress Signals

When a vessel is in distress and requires assistance, she shall use or exhibit any of the following signals (Ref. Pub. No. 102 International Code of Signals):

### Red Star Shells/Rockets

- A gun or other explosive signal fired at intervals of about one minute
- Continuous sounding of any fog- signaling apparatus
- Signal made by radiotelegraphy or by any other signaling method consisting of the group:  
 •••– – –•••(SOS) in Morse Code
- A signal sent by radiotelephony consisting of the spoken word "Mayday" or "Pan Pan." The format for sending a distress call is as follows:  
 "Mayday, Mayday, Mayday" or "Pan Pan, Pan Pan, Pan Pan;"  
 Vessel's Name and Call Sign, repeated three times; Distress Message.
- A "Mayday" distress call is given when the vessel is threatened by grave and imminent danger.  
 A "Pan Pan" distress call is given when the safety of a person on board or man over board is urgent, but not immediately dangerous.
- A signal consisting of a square flag having above or below it a ball or anything resembling a ball.
- Flames on board the vessel
- Rocket parachute flare or hand flare showing a red light
- Smoke signal giving off orange-colored smoke

- Slowly and repeatedly raising and lowering arms outstretched to each side
- The radiotelegraph alarm signal
- The radiotelephone alarm signal, transmitted on 2182 kHz and 156.8MHz.
- Signals transmitted by Emergency Position Indicating Radio Beacons (EPIRB); there are five types (A, B, C, S, and Category 1), transmitting on 121.5 Hz, 243 Hz, or to a satellite.
- Other approved signals transmitted by radio communication systems

# Nautical and Maritime College Terminology

## Hull Terminology

Aft:	Toward, at or near the stem
Abaft:	Behind; towards the stern or back end of the vessel
Abeam:	On the side of the vessel, perpendicular to centerline; 90 degrees from dead ahead
Aboard:	To be on a ship
Adrift:	Afloat but neither made fast to moorings nor at anchor; anything that is not secure or stowed in its proper place
Amidships:	The middle part of the ship, halfway between bow and stern
Ballast:	The seawater or any other substance carried in the deepest holds/tanks to keep positive stability.
Base Line:	A fore and aft datum line from which vertical heights are measured
Beam:	An athwart ship horizontal member supporting a deck or flat; the extreme width of the ship
Binnacle:	The stand that holds the ship's compass.
Bow:	The forward end of a ship
Bridge:	The elevated platform above the main deck from which the ship is navigated.
Bulkheads:	Walls that divide the ship into compartments.
Bulwarks:	Low metal walls built around the main and upper decks, they prevent waves from breaking over the decks; and people or objects from being washed overboard.
Camber:	The rise or crown of a deck, measured athwart ship in inches per foot of breadth
Centerline:	The fore and aft middle line of the ship from stem to stem
Companionway:	The steps which lead from one deck to another.
Dead rise:	The rise or slant up athwart ship of the bottom of a ship from the keel to the bilge
Depth:	The distance from the keel to the freeboard deck at the side
Draft:	The depth of the lowest point of the ship below the surface of the water when she is afloat
Forecastle: (foc'sle):	A raised deck near the bow.
Forward:	Means toward the front of the ship.
Forward Perpendicular:	A line perpendicular to the baseline, intersecting the forward edge of the stem at the designed water line
Freeboard:	Distance between the waterline and the uppermost continuous deck (main deck).
Funnel:	The smokestack.
Hatch:	Opening in the deck through which cargo is lowered into or hoisted out of a hold; or a salty name for a conventional door.
Helm:	The ship's steering wheel.
Holds:	Areas below deck in which cargo is stored.
Hull:	The body of a ship, indicating shell plating, framing decks and bulkheads
Inboard:	Inside the ship; toward the centerline
Keel:	The principle fore and aft member of a ship's frame, running along the bottom and connecting the stem and the stern; to which the frames of the ship are attached
Length on the Water Line:	Line of the surface of the water on a ship when loaded to maximum allowance in salt water in the summertime

Length Overall:	The length of a ship measured from the forward-most point of the stem to the after-most point of the stem
Keel:	The backbone of a ship. It is a ridge that runs along the lowest part of the hull from stem to stem.
Leeward Side:	The side of a ship away from the wind.
Moor:	To keep a ship in place with lines tied to a pier, to a buoy attached to an anchor, or to another ship.
Poop Deck:	A short raised deck at the rear of a ship.
Outboard:	Away from the centerline, toward the side of a ship
Propeller:	A revolving device that drives the ship through the water, consisting of three or more blades
Rudder:	A large heavy fitting, hinged to the stern frame, used for steering the ship
Shaft:	A long, round, heavy forging, connecting the engine and propeller or other rotating machinery to its parts
Sheer:	Fore and aft curvature of a deck
Stem:	A forged, casted or rounded plate forming the extreme bow of the ship, extending from the keel to the forecandle deck; also, the foremost part of a ship where the bow cleaves the water.
Stern:	The rear part of a ship.
Superstructure:	All the structures on a ship that rise above the main deck, a.k.a. the house.
Tween Decks:	Spaces above the holds of general cargo ships in which additional cargo may be stored.
Waterline:	The point on the hull that the surface of the water reaches.

### **Some Older Maritime College Terminology**

Bagged:	Being written up for a Class I or Class II offense.
Bug Juice:	The nectar served at mess during the warm months
Care Package:	A welcome change from mess hall chow
Century Club:	A group composed of present or future leaders who have "earned" 100 demerits
Channel Fever:	The feeling of anxiety one gets toward voyage's end
Chow:	Food
Chronometer:	An extremely accurate timepiece used in celestial navigation
Class System:	Just like a caste system, only with different reasons
Fudge Factor:	That mysterious consideration, which seems to make something always come out your way
Glory Bars:	Service ribbons
Gross:	Extremely poor; especially in reference to the appearance of something
Happy Hour:	Extracurricular courses in physical training
Holiday:	An area missed, as when painting
License Jitters:	That uneasy feeling among the first class when they realize that license exams are so very, very close
Mess:	A self-explanatory term joyously applied to the thrice daily gathering of the undernourished in Vander Clute Hall
Mixer:	An informal Maritime College dance attended by imported girls with the nicest personalities around
Over the Wall:	Unauthorized liberty
MUG Bible:	Boatswain's Pipe
Pony:	Old test or homework used as a study aid (pass on next year)
Probation:	Academic term used to denote a cadet who had better hit the books
Red Lead:	Catsup; special paint used at sea back in the old days as a primer.
Reg Head:	Someone who's tiny bit of power has gone to his or her head.
Reveille:	"Rise and shine for the maritime sailor"
Review:	A regimental stroll; good for breaking in liberty shoes
Room Captain:	A synonym for "it's your turn to clean the room and get stuck"

Scrambled Eggs:	Accumulation of gold on the hat of commanders and above
Sea Lawyer:	One that prefers to question rather than to obey orders
Sharp:	Being on the ball; good personal appearance
Shot Down:	To be completely demoralized, as after a test
Shove Off:	Exodus; get lost
Skivvies:	Under shorts, regulation of course
Skylarking:	Nautical daydreaming
Smoking Lamp is Lit:	Permission to smoke
Square Away:	"Straighten up", like a room
Statement:	A written reply to a Gold
Stuck:	To be placed on report
Tool:	Easily used cadet
Two-Block:	Hoist something all the way
Up the Hawespipe:	Obtaining a position of rank the hard way, by coming up through the ranks.
Wife:	Roommate (used mostly at Kings Point...go figure)

### **Today's Maritime College Terminology and Some Industry Terminology**

AB:	Able-Bodied Seaman; an unlicensed deck department rating
All hands:	A call that is made to the entire crew
Aloft:	In the upper rigging, masts, etc.
Amidships:	In the middle portion of the ship; having no angle on the rudder
ASAP:	As soon as possible
Ashore:	To be off a ship
Athwartships:	From side to side; across the ship; transversely
Aye:	To say "yes" or to reply in the affirmative
Ballast:	Dead weight material carried aboard ship to improve stability
Batten Down:	To cover up and fix down, especially to prepare for sea
Belay:	To make a rope or line fast or secure; to stop or cancel an action ("Belay my last")
Bilge:	The curved area of a ship where the sides and bottom join
Binnacle:	The stand enclosing the ship's magnetic compass
Blue Nose:	A sailor who has crossed the Arctic or Antarctic Circles
Boatswain:	"Bosun"; chief unlicensed rating in the deck department
Boatswain's Chair:	A seat or swing hung from a single line used for working aloft or over the side
Bow:	The front or forward part of a vessel
Box the Compass:	To repeat the 32 points of the compass rose in order (N, NxE, NNE, etc.)
Boxing Corners:	To square left, go right instead; to square right, go left instead
Bulkhead:	A vertical partition between compartments or spaces
Carry on:	To continue what you were doing
CAIDO:	Chief Academic Indoctrination Officer
CDIDO:	Chief Deck Indoctrination Officer
CEIDO:	Chief Engine Indoctrination Officer
CIDO:	Chief Indoctrination Officer
CPTIDO:	Chief Physical Training Indoctrination Officer
Deck:	The horizontal surface at the bottom of a space
Detail:	A special task; the number of people who perform this task
Dog:	To secure; as in "Dog a hatch"
Double time:	To move at 180 paces per minute, with 36-inch steps
Domer:	A Maritime College cadet or Alumnus. Refers to the white dome on top of the Fort.
ED:	Extra Duty; additional work as a result of receiving demerits
Eight Bells:	Eight rings of the ship's bell, signaling the end of the watch or signifying that all is well; also the Maritime College Yearbook.
Ensign:	The flag indicating a ship's nationality
Fantail:	The after-most part of the main deck; that section of deck which overhangs the sternpost

Field Day:	Clean up of an assigned area of the ship or dormitories
Fore and aft:	Along the length of the ship; longitudinally
Forward:	Towards the bow; at the forepart or front of a vessel
Fouled:	Entangled, jammed, not running clean
FWE:	Finished With Engines; a command on the Engine Order Telegraph, which indicates that maneuvering, is complete; a sign for cadets who have successfully passed their license exams
Galley:	The kitchen aboard ship
Gangway:	An order to make way or clear a path; a plank or ladder connecting the ship with the shore
Gold:	Cadet's copy of a Class I mast report.
Hatch:	Horizontal covering of an access between decks
Hawsepiper:	One who has achieved officer rank by advancing through unlicensed ratings
Head:	Latrine aboard a ship
House:	A ship's superstructure, enclosing living quarters, offices, the wheelhouse, etc.
IDO:	Indoctrination (Duty) Officer
Inboard:	Toward the centerline of a ship; toward the Quad side of the dorms
Irish Pennants:	Loose yarns or old rope ends hanging about that give a sloppy appearance; loose threads hanging from uniforms or uniform articles
Jack:	The national flag flown from the jack staff by a ship in port or at anchor
Jury rig:	A temporary fix or substitute solution
Keel:	The primary longitudinal strength member running along the bottom of a vessel; it is the foundation for a ship's frame;
Knock Off:	To end work for the day or to take a break
Ladder:	Access way between decks; shipboard stairs
Lanyard:	A short length of line used to secure gear or to attach a piece of equipment
Leeward:	The side of the ship opposite to that upon which the wind is blowing
Liberty:	Authorized leave to go ashore
Logbook:	A ship's journal into which is recorded all official activities and conditions
Mast:	A brief hearing to resolve disciplinary charges
MUG:	Cadet Under Guidance; slang for a fourth class cadet
Muster:	To assemble the crew for a roll call prior to resuming work
MO FO:	Morning formation
OS:	Ordinary Seaman; entry level rating in the deck department
Outboard:	Toward or outside the hull; away from centerline; the side of the dorms not facing the Quad
Overhead:	The horizontal surface above a space
Pink:	Cadet's copy of a Class II mast report
Pipe:	To summon or pass word via public address system
Police:	To tour an area for the purpose of cleaning up trash and debris
Pollywog:	One who has not sailed across the Equator
Port:	The left hand side of a ship when facing forward
QMED:	Qualified Member of the Engine Department; unlicensed seaman competent in the practical aspects of engine room operation
Rack:	The piece of furniture you rest your bones on
Rate:	A first class cadet who is a cadet officer; what is required of each class of cadet and what he/she is allowed
Restriction:	Requirement to remain on ship or on campus as a result of disciplinary infractions
Scuttlebutt:	Water fountains aboard ship; ship's gossip or rumors
Screw:	The propeller of a ship; something you figure out at Maritime.
Shellback:	A sailor who has crossed the Equator
Shipshape:	Seamanlike in appearance; organized and ready for service
Sickbay:	Space aboard a ship for the treatment of sick and injured
Square Away:	To make something neat and orderly

Starboard:	The right hand side of a ship when facing forward
STCW:	Standards of Training and Certification of Watchkeepers – the international standards to which every seafarer, both licensed and unlicensed, must comply. Based on your rating, it consists of a series of check offs which must be completed to achieve proficiency.
Stern:	The back end or after part of the vessel
Stow:	To put something in a secure place for future use
Squad Leader:	A third class cadet selected to assist IDOs in training the fourth class
Swab:	A mop; Coast Guard Academy 4/c
SWL:	Safe Working Load; a measurement of the tension a line can safely withstand
Tool:	A Cadet who excessively resorts to writing up cadets to solve his or her own problems.
Topside:	On or about the weather deck
Thwart:	Transverse seats in a lifeboat
Trooper:	A non-rated first class cadet
Windward:	The side of the ship upon which the wind is blowing

## MUG Knowledge

The fourth class shall commit to memory:

- Names and Titles of Administrative Heads
- Cadet Officers with 4 Stripes/Bars and Above
- Resident Company Rates
- The Maritime College Oath
- The Reisenberg Saying
- The Sally Port Saying
- “The Bells of *St. Mary’s*” (*Alma Mater of the Maritime College*)
- “Anchors Aweigh”
- “How Long Have You Been a Sailor?”
- Location of the Center of *St. Mary’s* Pentagon
- Nautical and Maritime College Terminology
- Ship’s Officers, *TSES VI*
- Ship’s Particulars
- Additional material as provided by IDOs

### The Maritime College Oath

I will conduct my personal and professional behavior, both on and off campus, in a manner which will bring credit to the Maritime College, myself, and the profession for which I am preparing.

I will observe those standards of honesty, integrity, moral courage, and personal honor which are expected of all professionals associated with the Merchant Marine.

I agree to abide by the Rules and Regulations for the Regiment of Cadets of the Maritime College.

### The Reisenberg Saying

“The sea is selective, slow at recognition of effort and aptitude, but fast in sinking the unfit.”

Felix Reisenberg, Jr.



## **The Sally Port Saying**

“...but men and officers must obey, no matter at what cost to their feelings, for obedience to orders, instant and unhesitating, is not only the life blood of armies, but the security of states, and the doctrine that under any conditions whatever, deliberate disobedience can be justified, is treason to the commonwealth.”

From the biography of *Stonewall Jackson and the American Civil War*, by Colonel G. Henderson.

## **“The Bells of *St. Mary’s*”**

*Alma Mater of the Maritime College*

The bells of *St. Mary’s* Ah! Hear! They are calling  
The old lads, the new lads who’ve gone to the sea;  
Our dear Alma Mater, we hear your voice calling,  
The ship’s bells shall ring out, ring out for you and me.

The bells of *St. Mary’s* at sweet even’ tide  
Shall call her beloved to come to her side;  
And dear Alma Mater in the sound of the sea,  
I know you have been waiting, yes, waiting for me.

The bells of *St. Mary’s*, Ah! Hear! They are calling  
The old lads, the new lads goin’ down to the sea;  
And so, my Beloved, when blue seas are calling,  
The ship’s bells shall ring out; ring out for you and me.

## **“Anchors Aweigh”**

Anchors aweigh my boys, anchors aweigh,  
Farewell to college joys, we sail at the break of day, day, day, day,  
On our last night ashore, drink to the dome,  
Until we meet once more, here’s wishing you a happy voyage home.

## **“How Long Have You Been a Sailor?”**

“All me bloomin’ life, Sir/Ma’am,  
Me father was King Neptune, me mother was a mermaid,  
I was born on ’de crest of a wave, and rocked in ’de cradle of ’de deep,  
Me eyes is stars, me teeth is spars, me hair is hemp and seaweed,  
And when I spits (pretending to spit), I spits tar,  
I’s tough, I is, I am, I are, Sir/Ma’am.”

## **The Heave Ho Song**

Heave-Ho! My Lads, Heave-Ho!  
It's a long, long way to go  
It's a long, long pull  
With the hatches full  
Braving the wind  
Braving the sea  
Fighting the treacherous foe  
Heave-Ho! My lads, Heave-Ho!  
Let the waves roll high or low  
We can cross any ocean  
Sail any river  
Give us the goods and we'll deliver  
Damn the submarine!  
We're the men of the Merchant Marine!

## **Fourteen Leadership Traits (JJ-DID-TIE-BUCKLE)**

**J**udgment  
**J**ustice  
**D**ecisiveness  
**I**ntegrity  
**D**ependability  
**T**act  
**I**nitiative

**E**ndurance  
**B**earing  
**U**nselfishness  
**C**ourage  
**K**nowledge  
**L**oyalty  
**E**nthusiasm

## **College Motto**



*LOYALTY and VALOR*

































## **Location of the Center of *St. Mary's* Pentagon**

Latitude: 40° 48.3' North  
Longitude: 073° 47.5' West

## US Navy and US Coast Guard Enlisted and Officer Rates and Ranks

The following tables show the rate/rank and insignia of enlisted and officers in the US Navy and US Coast Guard. You are expected to know enlisted and officer pay grades, rate/rank, and insignia. Note that the Ensign collar insignia is very close to that of a 1<sup>st</sup> Class Trooper. Also note the O-11 rank of Fleet Admiral; this rank is used only during times of a Congressionally Declared War.

Pay Grade	Rate	Abbreviation	Upper Sleeve	Collar and Cap
E-1	Seaman Recruit	SR	none	none
E-2	Seaman Apprentice	SA		none
E-3	Seaman	SN		none
E-4	Petty Officer Third Class	PO3		
E-5	Petty Officer Second Class	PO2		
E-6	Petty Officer First Class	PO1		
E-7	Chief Petty Officer	CPO		
E-8	Senior Chief Petty Officer	SCPO		
E-9	Master Chief Petty Officer	MCPO		

Pay Grade	Rank	Abbreviation	Collar	Shoulder	Sleeve
O-1	Ensign	ENS			
O-2	Lieutenant Junior Grade	LTJG			
O-3	Lieutenant	LT			
O-4	Lieutenant Commander	LCDR			
O-5	Commander	CDR			
O-6	Captain	CAPT			
O-7	Rear Admiral (lower half)	RDML			
O-8	Rear Admiral (upper half)	RADM			
O-9	Vice Admiral	VADM			
O-10	Admiral	ADM			
O-11	Fleet Admiral*	FADM			

# The Training Ship

## Training Ships of the Maritime College

1874 - 1908 *USS St. Mary's*  
1908 - 1931 *USS Newport*  
1931 - 1946 *Empire State I*  
1946 - 1956 *Empire State II*  
1956 - 1959 *Empire State III*  
1959 - 1973 *Empire State IV*  
1973 - 1990 *Empire State V*  
1990 - Present *Empire State VI*

## *TS Empire State VI*

The College's current training vessel was laid down as Hull #552 at the Newport News Shipbuilding and Dry-dock Co., of Newport News, Virginia.

Designed by the George C. Sharp Co. as a Mariner Class C4-S-IU break-bulk freighter, she was launched on September 16, 1961, and was commissioned in 1962 as the *SS Oregon* of the States Steamship Lines. She served in the Pacific trades through the 1960s.

The *Oregon* was purchased by Moore-McCormack Lines in the early 1970s and was renamed *SS Mormactide*. Moore-McCormack operated her on the South American run. Briefly under the ownership of United States Lines, the vessel was laid up at the James River Ready Reserve Fleet in December 1982.

In November 1988, the idle *Mormactide* was towed to Bay shipbuilding Corporation of Sturgeon Bay, Wisconsin, to begin training ship conversion. She was delivered to the College pier on December 31, 1989 and was recommissioned *TS Empire State VI* on May 5, 1990.

## Ship's Officers

Master	Richard Smith
Chief Mate	Matt Mahanna
Second Mate	Peter Vecchio
Third Mate	John Flannigan
Chief Engineer	Ed Robinson
First Assistant Engineer	William McCaney
Second Assistant Engineer	Dominick Valvo

## Ship's Particulars

Official Hull Number:	287875
Maritime Administration Classification:	Public Nautical School ship s5-5-MAIua
Call Sign:	KKFW (Kilo Kilo Foxtrot Whiskey)
Length, Overall:	565 feet or 172.2 meters
Length Between Perpendiculars:	528 feet
Beam:	76 feet or 23.16 meters
Depth:	44 feet 6 inches
Designer's Draft:	25 feet
Height of Radar Mast above Keel:	137 feet 11½ inches
Light Ship Tonnage:	12,116 Long Tons (LT)
Total Displacement: Normal:	17,160 LT
Maximum:	19,350 LT
Total Compliment:	791
Cadets:	684

Crew:	107
Anchors:	Baldr Stockless; 1 port, 1 starboard; 12,945 lbs each
Anchor Cable:	11 shots on each anchor
Cargo Gear:	
Hatch 1:	Two 52 ft. booms, 5 ton SWL at 31° from vertical
Hatch 2:	Two 60 ft. booms, 5 ton SWL at 31° from vertical
Hatch 6:	Crane, 22,000 lbs. SWL
Hatch Covers:	
Hatches 1 and 2:	Hydraulic
Hatch 6:	Manual
Propulsion:	Steam turbine, single screw
Main Engine:	Newport News geared turbine, cross-compounded
High-pressure turbine:	impulse type blading.
Low pressure turbine:	impulse/reaction type blading.
Boilers:	2 Foster Wheeler D-type steam generators; 600 psig at 860°F, with interdeck super heaters
Reduction Gears:	General Electric articulated double reduction gears
Generators:	2 General Electric Ship Service Steam TurboGenerators, 750 kW each
1 Caterpillar Diesel, Auxiliary, 1200 kW	
1 Caterpillar Diesel, Emergency, 250 kW	
Sustained Sea Speed:	20 knots
Cruising Range at 20 knots:	16,000 nautical miles
Horsepower:	
Normal:	17,250
Maximum:	19,250
Total Potable Water Capacity:	959 LT
Total Distilled Water Capacity:	238 LT
Total IFO 180 Fuel Oil Capacity:	2404 LT
Total Diesel Oil Capacity:	234 LT
Fresh Water Production:	2 Flash Distilling units, 8,000 gallons per day (GPD) each
1 Nirex Distilling unit, 25,000 GPD	
1 Reverse Osmosis unit,	
Propeller:	One 4-bladed, right-handed; nickel-aluminum-bronze alloy
Propeller Diameter:	22 feet
Propeller Pitch:	22 feet 6 inches

## Basic Steam Water Cycle

The Basic Steam Water Cycle gives a very basic idea of the different pieces of equipment involved in steam generation on the *Empire State* and how they fit together. One of the key points to note is that it is a cycle, number one (1) and twelve (12) is the same piece of equipment.

- |                          |                       |
|--------------------------|-----------------------|
| 1. Boiler                | 7. Air Ejector        |
| 2. Throttle Box          | 8. First Stage Heater |
| 3. High Pressure Turbine | 9. DC Heater          |
| 4. Low Pressure Turbine  | 10. Feed Pump         |
| 5. Condenser             | 11. Economizer        |
| 6. Condensate Pump       | 12. Boiler            |

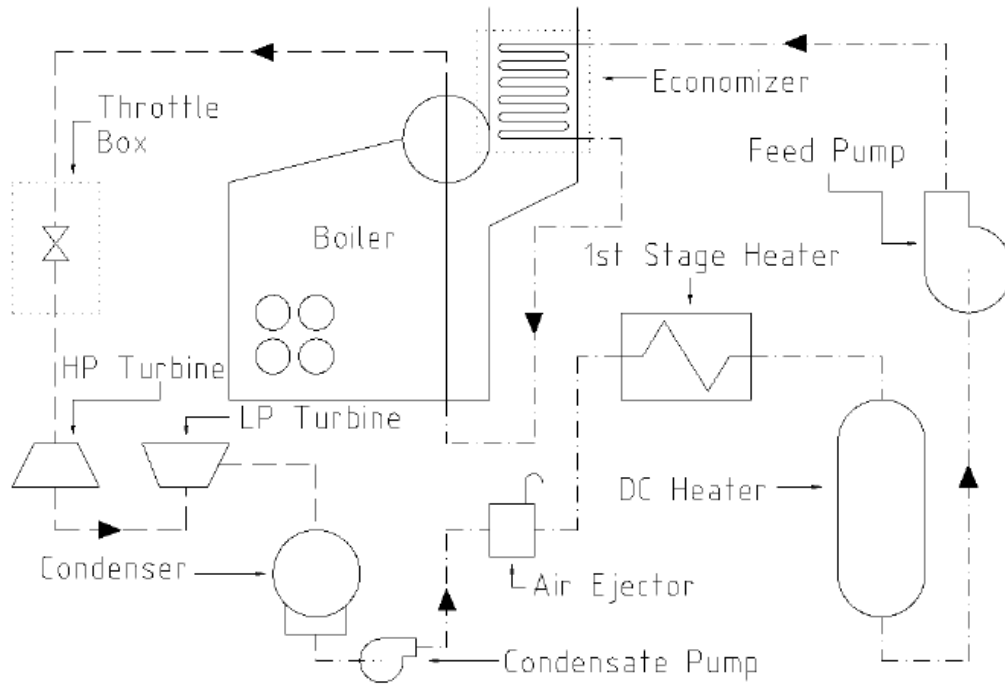

Dash lines represent steam, dot-dash lines represent water, arrows show flow through the cycle

### Point System

The "Point System" is commonly used by lookouts and other watch standers for referencing the direction or bearing objects are in relation to the ship.

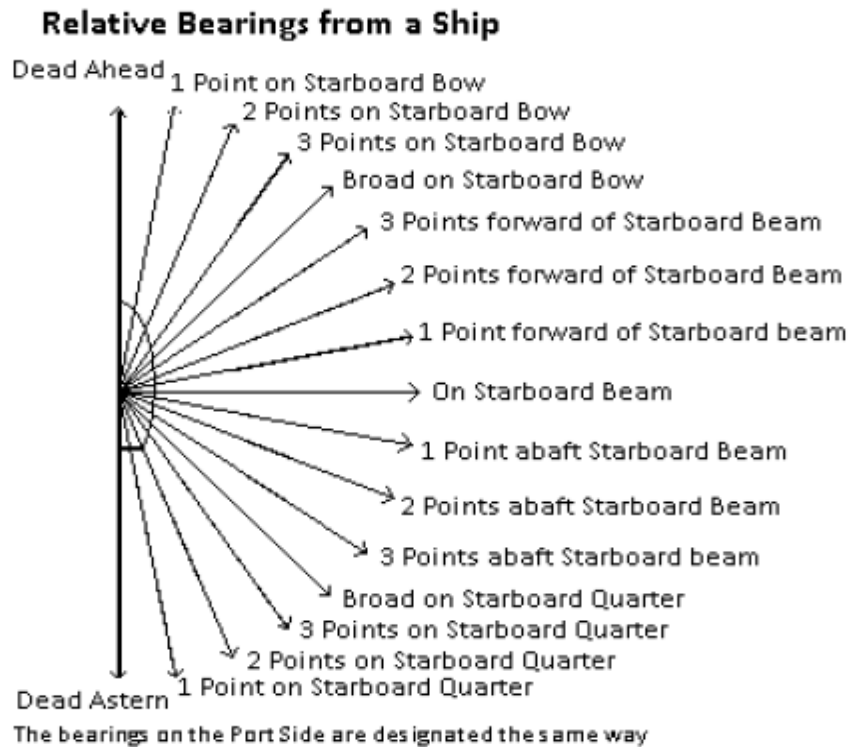

## Emergency Signals

The following signals are used on the *TS Empire State* and commercial vessels to inform the crew of an emergency or other situation on the ship. It is essential that all cadets memorize and be able to recognize these signals, it may save your life one day!

- **Fire and Emergency:** A continuous sounding of the ship's whistle and general alarm for more than ten (10) seconds  
-----
- **Man Overboard:** Three (3) prolonged blasts on the ship's whistle and general alarm  
-----
- **Abandon Ship:** More than six (6) short blasts followed by one (1) prolonged blast on the ship's whistle and general alarm  
.....-----
- **Lifeboat Orders :**
  - **Lower Boats:** One (1) short blast on the ship's whistle  
.
  - **Stop Lowering Boats:** Two (2) short blasts on the ship's whistle  
..
  - **Dismiss from Boat Stations/Drill:** Three (3) short blasts on the ship's whistle  
...  
...

## Nautical Conversions

1 fathom = 6 feet

1 shot = 15 fathoms = 90 feet

1 cable = 120 fathoms

1 nautical mile = 6076 feet = 1 minute of Latitude

1 knot = 1 nautical mile per hour

1 nautical mile = 1.151 statute miles

1 degree = 60 minutes

1 long ton (LT) = 2240 lbs = 35 cubic feet of seawater

1 short ton = 2000 lbs



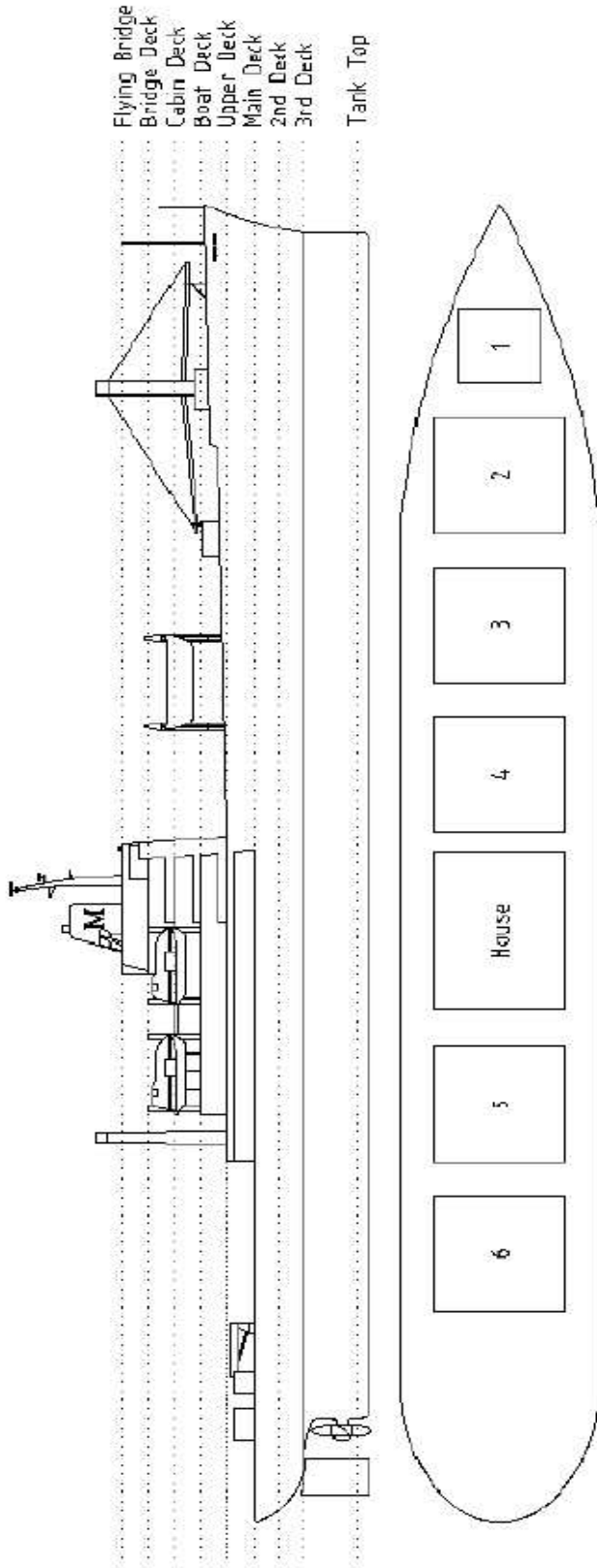

### Navigating the Ship

Accurately knowing where you are while onboard the training ship and knowing how to get to where you need to be is essential.

The *Empire State* is divided into nine (9) decks from top to bottom, and six (6) holds from bow to stern.

- Flying Bridge
- Bridge Deck
- Cabin Deck
- Boat Deck
- Main Deck
- 2<sup>nd</sup> Deck
- 3<sup>rd</sup> Deck
- Tank Top

The six holds are simply numbered from bow to stern, one through six, with one being closest to the bow and six closest to the stern. The "House", labeled above, contains the machinery space.

## Life Boats

Life Boat	Capacity	Location
Lifeboat #1: Open	145 persons	Foredeck, Stbd
Lifeboat #2: Open	145 persons	Foredeck, Port
Lifeboat #3: Enclosed	76 persons	Boat Deck, Stbd, outside C/M's office
Lifeboat #4: Enclosed	76 persons	Boat Deck, Port, outside C/E's office
Lifeboat #5: Enclosed	76 persons	Sun Deck, Stbd
Lifeboat #6: Enclosed	76 persons	Sun Deck, Port

## Life Rafts

Life Raft	Capacity	Location
Life Rafts: 7, 9, 11, 13	25 persons each	Upper Deck, Stbd Side, Aft
Life Rafts: 8, 10, 12, 14	25 persons each	Upper Deck, Port Side, Aft
Additional Life Rafts (2)	25 persons each	Cabin Deck, Port/Stbd Side

## Survival Craft (Lifeboat/Life Raft) Equipment- 46 CFR 199.175

Bailer	First Aid Kit	Oars/Paddles	Signal (Smoke, Hand, and Parachute Flare)
Bilge Pump	Fishing Kit	Painter	Sponge
Boathook	Flashlight	Provisions (Food)	Survival Instructions
Bucket	Hatchet	Radar Reflector	Table of Lifesaving Signals
Can Opener	Heaving Line	Rainwater Collection Device	Thermal Protective Aids
Compass	Jackknife	Repair Kit	Tool Kit
Dipper	Knife	Sea Anchor	Towline
Drinking Cup	Ladder	Searchlight	Water
Fire Extinguisher	Mirror, Signaling	Seasickness Kit	Whistle

## Emergency Gear Lockers (EGL)/Damage Control Lockers (DC Lockers)

EGL #1	Foredeck, After Doghouse, Port	(Bow)
EGL #2	Second Deck, Athwartship Passageway	(Side Ports)
EGL #3	Second Deck, 6-Hold, Stbd, Aft	(6-Hold)
EGL #4	Third Deck, 5-Hold, Stbd, Aft	(Classrooms)
EGL #5	Auxiliary Machinery Space	(AMS)

## Sample EGL/DC Locker Equipment:

All Purpose Fire Nozzles	Lifeline (O.A.T.H.)	Burn Kits
CO <sub>2</sub> Fire Extinguishers	First Aid Kits	Burn Blankets
Dry Chem. Extinguishers	Flashlights	Radios
Fire Applicators	Reducers	AFFF (Foam)
Fire Axes	Wye Gate Valves	Spanner Wrenches
Firefighter's Ensemble	Vary Nozzles	Litters/Baskets
SCBAs	Fire Hoses	
Spare Air Bottles	Fire Hose Couplings	

## Classes of Fire

- Class A: Common Combustibles (paper, rubbish, cloth); combated with water or soda acid
- Class B: Flammable liquids and gases (oil, grease, gasoline); combated with foam or carbon dioxide
- Class C: Electrically Induced (lighting, motors, circuitry); combated with carbon dioxide or dry chemical
- Class D: Burning Metals (sodium, aluminum, pyrotechnics); combated with dry powder

## Basic Ship Safety Information

*"Safety is the business of all hands. The consequences of neglect of safety can be tragic. More than 50% of all accidents aboard ship are caused by not following safety practices."*

-American Merchant Seaman's Manual

### Doors/Hatches:

- Secured Properly; "Dogged"
- Maintain control of heavy doors or hatches until they are secured or controlled by another person

### Tools:

- Ensure they are in good condition prior to use (no rust or corrosion on the tool, working end, or power cord)
- Tie off or secure if used aloft or over the side
- Ensure you are familiar with or qualified in the operation of each tool or piece of equipment you plan to use, depending on the task or project.

### Electrical:

- Ensure power is secured prior to working on equipment or opening panels
- Ensure you are wearing rubber gloves, rubber-soled shoes or boots, and goggles or a face shield
- You should not be wearing any metal objects, such as rings, watches, or necklaces
- Ensure you are familiar with or qualified to repair the equipment you plan to work on
- Do not operate or attempt repairs to any equipment which is tagged out without prior permission from the appropriate Engineering Officer
- Do not touch bare wire, damaged wires, or panels- assume all circuits are live unless tested otherwise

### Working Aloft or Over the Side:

- Ensure you are using a proper harness that is not corroded, frayed, worn, or has excessive paint, oil, or other substances on it which might affect the functionality of the harness.
- Ensure any equipment which is in the vicinity of where you will be working (such as radars on the radar mast) is secured or will not affect your ability to safely work in the area specified
- Attach all loose tools or items with lanyards or safety line/cord to fixed parts of the vessel
- Ensure you are wearing appropriate PPE for the job at hand, including safety goggles, gloves, a respirator, etc.

## Summer Sea Term

The Summer Sea Term (SST) is an integral part of the Maritime College curriculum. Except for those with prior experience, every cadet is required to complete three summers sea terms. Cadets are the crew of the *Empire State VI*. Under the close supervision of licensed officers, cadets operate and maintain the vessel. This successful blend of operational training and leadership development has been the hallmark of the Maritime College for over 120 years.

During your first summer sea term, you will be in an entry-level position. You will be exposed to the basic skills necessary to become a good leader and officer. You will become familiarized with the vessel and will be trained in the basic practices of the seagoing profession. Your days will include watch standing, attending classes and labs, and performing vessel sanitation and maintenance.

As your second summer sea term begins, you will be ready to assume a more skilled position aboard the ship. Responsibilities are increased: you begin to assist in the supervision of personnel and professional tasks.

Finally, with your third summer sea term come the responsibilities and privileges of a cadet officer. First class cadets run the ship. This is one of the most meaningful experiences in the career of a Maritime College cadet.

During the course of each summer sea term, you will have the opportunity to visit a variety of countries with diverse cultures. You are urged to take advantage of organized tours to see the sights when ashore. Use common sense as a guide to conduct in foreign ports. Respect the laws of each country and act responsibly. Your conduct will reflect upon both the Maritime College and the United States.

The summer cruises are memorable experiences that will be with you for a lifetime. You will learn the practical aspects of sea-going life, and you will gain valuable experience for a future position in the maritime industry. Nothing reinforces education and training better than the practical application of that which you are taught. This is what summer sea term is all about.

## Telephone Numbers

Maritime College phone extensions are located in the (718) area code. When dialing any extensions, dial (718)409-Campus Extension.

### Campus Extensions

Cadet Watch Office 7454 Office of Student Housing 5567

University Police 7311 Registrar 7266

IDO / SQL Program Office 7450 Office of the Commandant 7352

Sickbay 7347 (Anderson Smith)

### Ground Travel

Amtrak 800-USA-RAIL

Greyhound 800-231-2222

Blue Bird Cab 632-0909

Zero Cab Co. 822-2222

### Airlines

American 800-433-7300

Delta 800-221-1212

US Air 800-428-4322

United 800-631-1500