

FLOOR PLAN

0 2 4
SCALE IN FEET

NOTES FOR FLOOR PLAN

- (N1) LEAN-TO SIDE WALL POSTS, SEE POST/FOOTING SCHEDULE, THIS SHEET.
- (N2) GABLE WALL 6" x 6" POSTS - FOOTING DIMENSIONS, B = 2'-0"; T = 3'-0".
- (N3) PURLINS AT 2'-0" O.C.

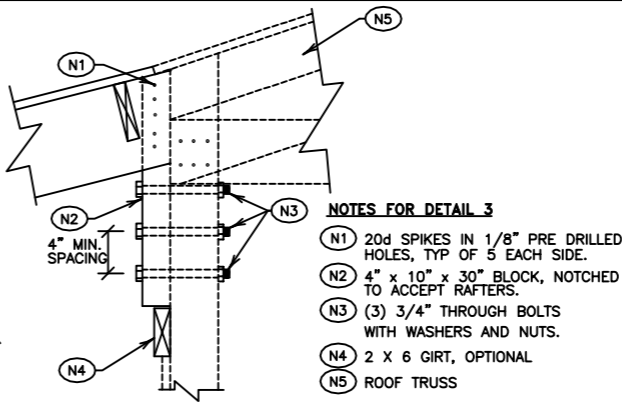

DETAIL 3 - OPTIONAL RAFTER COLUMN CONNECTION

0 1
SCALE IN FEET

NOTES FOR DETAIL 3

- (N1) 20d SPIKES IN 1/8" PRE DRILLED HOLES, TYP OF 5 EACH SIDE.
- (N2) 4" x 10" x 30" BLOCK, NOTCHED TO ACCEPT RAFTERS.
- (N3) (3) 3/4" THROUGH BOLTS WITH WASHERS AND NUTS.
- (N4) 2 X 6 GIRTS, OPTIONAL.
- (N5) ROOF TRUSS

NOTES FOR FOOTING DETAIL

- (N1) TREATED POSTS AS SIZED PER SCHEDULE.
- (N2) VIBRATE OR ROD CONCRETE TO OBTAIN FULL BEARING OR INSTALL 8" THICK X 16"Ø PRECAST CONCRETE PAD.
- (N3) UNDISTURBED NATIVE STABLE SOIL.
- (N4) TREATED 2" x 4" POST SUPPORT, OPTIONAL.

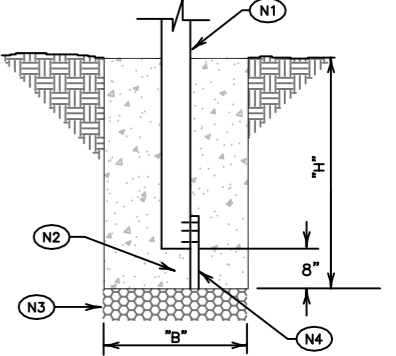

FOOTING DETAIL

N.T.S.

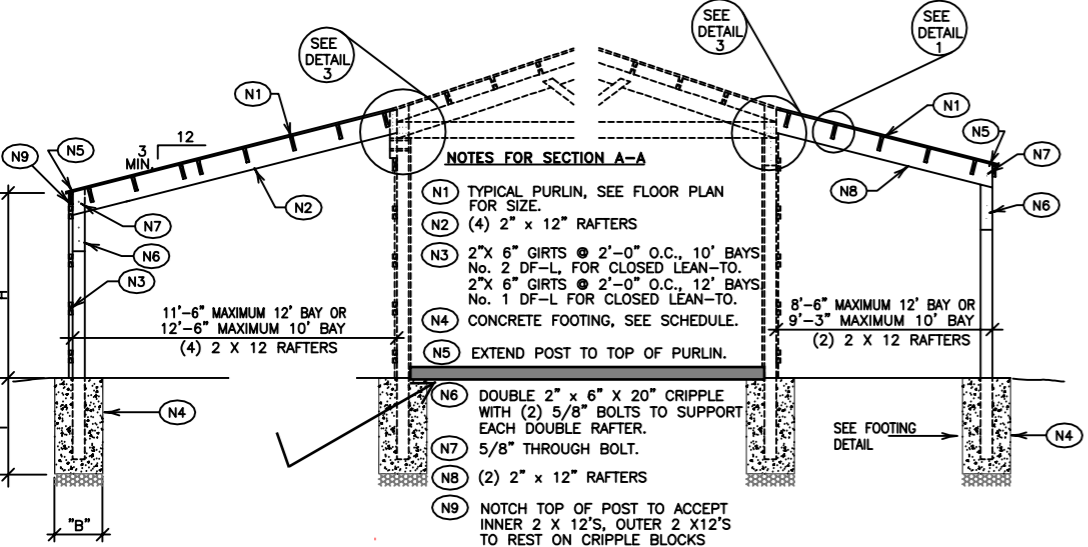

BUILDING SECTION A - A, RAFTER OPTION

0 2 4
SCALE IN FEET

NOTES FOR SECTION A-A

- (N1) TYPICAL PURLIN, SEE FLOOR PLAN FOR SIZE.
- (N2) (4) 2" x 12" RAFTERS
- (N3) 2" x 6" GIRTS @ 2'-0" O.C., 10' BAYS No. 2 DF-L, FOR CLOSED LEAN-TO. 2" x 6" GIRTS @ 2'-0" O.C., 12' BAYS No. 1 DF-L FOR CLOSED LEAN-TO.
- (N4) CONCRETE FOOTING, SEE SCHEDULE.
- (N5) EXTEND POST TO TOP OF PURLIN.
- (N6) DOUBLE 2" x 6" x 20" CRIPPLE WITH (2) 5/8" BOLTS TO SUPPORT EACH DOUBLE RAFTER.
- (N7) 5/8" THROUGH BOLT.
- (N8) (2) 2" x 12" RAFTERS
- (N9) NOTCH TOP OF POST TO ACCEPT INNER 2 X 12'S, OUTER 2 X 12'S TO REST ON CRIPPLE BLOCKS

NOTE: PURLIN CONNECTION METHODS

- A). PURLINS MAY BE HUNG OFF OF TRUSS TOP CHORD OR RAFTER FACES WITH STD. SIMPSON JOIST HANGERS OR EQUAL.
- B). PURLINS MAY BE BUTTED AND NAILED WITH (2) 16d NAILS INTO EACH PURLIN.
- C). PURLINS MAY BE LAPPED AND NAILED WITH (3) 16d NAILS.

ON CONNECTION METHODS 'B' and 'C' TOENAIL BACK SIDE OF PURLIN WITH (1) 16d NAIL INTO EACH TOP CHORD MEMBER

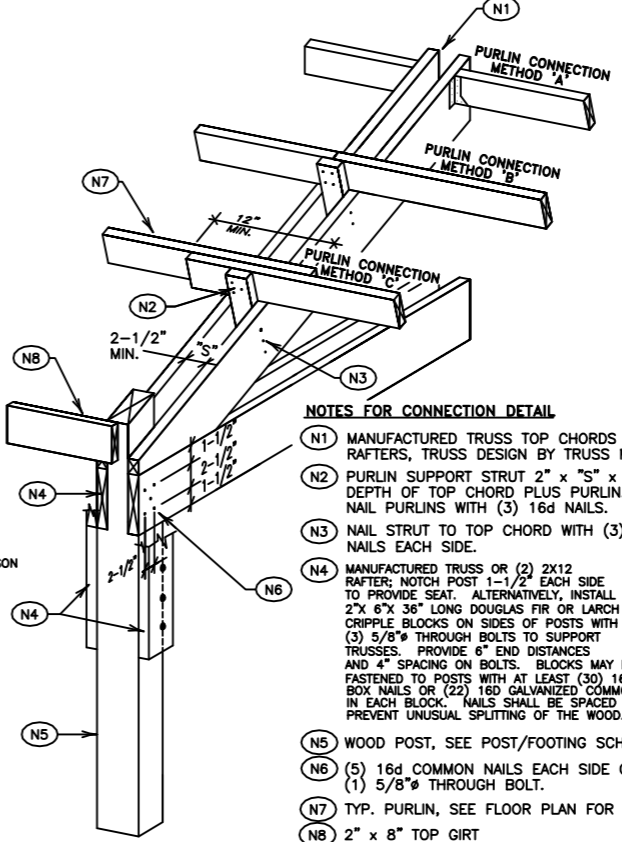

DETAIL 1 - TRUSS-COLUMN OR RAFTER-IN CONNECTION, PURLIN SUPPORT

N.T.S.

NOTES FOR CONNECTION DETAIL

- (N1) MANUFACTURED TRUSS TOP CHORDS OR 2" x 12" RAFTERS, TRUSS DESIGN BY TRUSS MANUFACTURER.
- (N2) PURLIN SUPPORT STRUT 2" x "S" x FULL DEPTH OF TOP CHORD PLUS PURLIN. NAIL PURLINS WITH (3) 16d NAILS.
- (N3) NAIL STRUT TO TOP CHORD WITH (3) 16d NAILS EACH SIDE.
- (N4) MANUFACTURED TRUSS OR (2) 2X12 RAFTER; NOTCH POST 1-1/2" EACH SIDE TO PROVIDE SEAT. ALTERNATIVELY, INSTALL 2" x 6" x 36" LONG DOUGLAS FIR OR LARCH CRIPPLE BLOCKS ON SIDES OF POSTS WITH (3) 5/8" THROUGH BOLTS TO SUPPORT TRUSSES. PROVIDE 6" END DISTANCES AND 4" SPACING ON BOLTS. BLOCKS MAY BE FASTENED TO POSTS WITH AT LEAST (30) 16d GALVANIZED BOX NAILS OR (22) 16d GALVANIZED COMMON NAILS IN EACH BLOCK. NAILS SHALL BE SPACED AS REQUIRED TO PREVENT UNUSUAL SPLITTING OF THE WOOD.
- (N5) WOOD POST, SEE POST/FOOTING SCHEDULE.
- (N6) (5) 16d COMMON NAILS EACH SIDE OR (1) 5/8"Ø THROUGH BOLT.
- (N7) TYP. PURLIN, SEE FLOOR PLAN FOR SIZE.
- (N8) 2" x 8" TOP GIRTS

LEAN-TO POST/FOOTING SCHEDULE

BAY SPACING	COLUMN		FOOTING	
	"H"	W X D	"B" DIA.	"T"
10' BAY	8'-0"	6" X 6"	2'-0"	3'-0"
	10'-0"	6" X 6"	2'-0"	3'-0"
	12'-0"	6" X 6"	2'-0"	3'-0"
	14'-0"	6" X 8"	2'-0"	3'-0"
12' BAY	8'-0"	6" X 6"	2'-0"	3'-0"
	10'-0"	6" X 6"	2'-0"	3'-0"
	12'-0"	6" X 8"	2'-0"	3'-0"
	14'-0"	6" X 8"	2'-0"	3'-0"

GABLED END WALLS AND OPEN LEAN-TO: USE 6" X 6" POSTS ALL HEIGHTS.

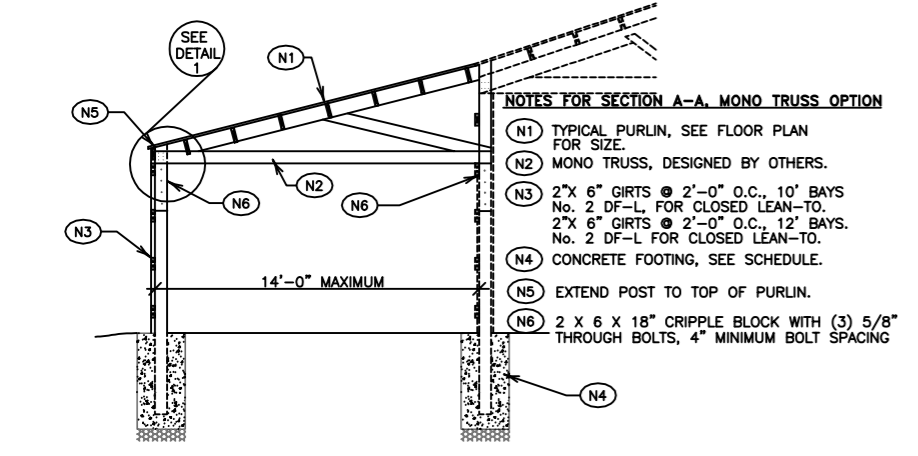

BUILDING SECTION A - A, MONO-TRUSS OPTION

0 2 4
SCALE IN FEET

NOTES FOR SECTION A-A, MONO TRUSS OPTION

- (N1) TYPICAL PURLIN, SEE FLOOR PLAN FOR SIZE.
- (N2) MONO TRUSS, DESIGNED BY OTHERS.
- (N3) 2" x 6" GIRTS @ 2'-0" O.C., 10' BAYS No. 2 DF-L, FOR CLOSED LEAN-TO. 2" x 6" GIRTS @ 2'-0" O.C., 12' BAYS No. 2 DF-L FOR CLOSED LEAN-TO.
- (N4) CONCRETE FOOTING, SEE SCHEDULE.
- (N5) EXTEND POST TO TOP OF PURLIN.
- (N6) 2 X 6 X 18" CRIPPLE BLOCK WITH (3) 5/8" THROUGH BOLTS, 4" MINIMUM BOLT SPACING

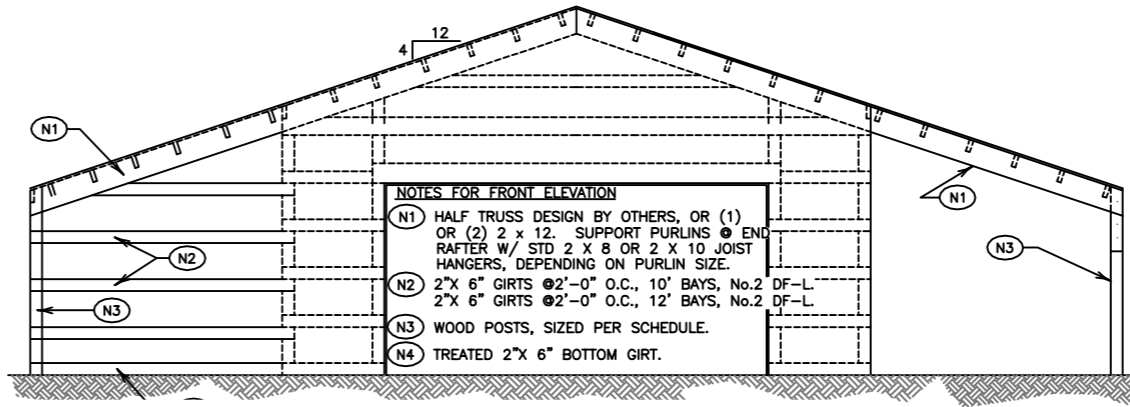

NOTES FOR FRONT ELEVATION

- (N1) HALF TRUSS DESIGN BY OTHERS, OR (1) OR (2) 2 x 12. SUPPORT PURLINS @ END RAFTER W/ STD 2 X 8 OR 2 X 10 JOIST HANGERS, DEPENDING ON PURLIN SIZE.
- (N2) 2" x 6" GIRTS @ 2'-0" O.C., 10' BAYS, No.2 DF-L. 2" x 6" GIRTS @ 2'-0" O.C., 12' BAYS, No.2 DF-L.
- (N3) WOOD POSTS, SIZED PER SCHEDULE.
- (N4) TREATED 2" x 6" BOTTOM GIRTS.

0 2 4
SCALE IN FEET

MAXIMUM SOIL BEARING PRESSURE IS BASED UPON SAND, SILTY SAND OR CLAYEY SAND (SW, SP, SM, OR SC) SOILS OR BETTER. LESSER SOIL CONDITIONS WILL REQUIRE REVIEW AND FOOTING SIZE ADJUSTMENT BY THE ENGINEER.

CONCRETE - MINIMUM 28 DAY COMPRESSIVE STRENGTH = 2500 PSI. CAST-IN-PLACE CONSTRUCTION SHALL CONFORM TO ACI 318-05.

WOOD - STRUCTURAL LUMBER SHALL CONFORM TO DF-L NO. 2 OR BETTER BY WPA GRADING RULES. MAXIMUM MOISTURE CONTENT SHALL BE 19% BY WEIGHT. NAILING SHALL CONFORM TO TABLE 2304.9.1 AND OTHER APPLICABLE SECTIONS OF CHAPTER 23 OF THE IBC. TREATED WOOD SHALL CONFORM TO THE REQUIREMENTS OF AWPB LB-22. POSTS SHALL BE NO. 2 HEM-FIR OR BETTER BY WPA GRADING RULES. ALL POST MATERIALS SHALL BE FULL DIMENSION. 6" X 8" POSTS MAY BE CONSTRUCTED OF A 6" X 6" WITH FULL LENGTH 2" X 6" NAIL LAMINATED TO POST INTERIOR. NAIL WITH (2) 16d NAILS AT 9" O.C. HARDWARE SHALL BE SIMPSON OR APPROVED EQUAL.

STEEL BOLTS - ALL STEEL BOLTS SHALL BE ASTM GRADE 307 OR BETTER.

METAL PANELS - METAL PANELS SHALL BE DELTA RIB STYLE GALVANIZED, MIN. 29ga GSG, GRADE E OR BETTER. PANELS SHALL BE FASTENED WITH GALVANIZED, GASKETED, METAL-TO-WOOD, 1" SCREWS. PANELS SHALL BE INSTALLED PER MANUFACTURER'S RECOMMENDATIONS.

SOIL COMPACTION - ALL BACKFILLED SOIL BENEATH SLABS OR FOOTINGS SHALL BE COMPACTED WITH A VIBRATORY COMPACTOR TO 95% OF THE MAXIMUM DENSITY AS DETERMINED BY ASTM 1557.

Note:
Use of these drawings shall be limited to general, Non-Commercial Construction in Pend Oreille County. Pend Oreille County will not accept any responsibility outside of its jurisdiction and is not responsible for any construction that deviates from the original design drawings.