

RFQ # 15383  
ENG

Quotation Due By: 04/24/2013  
Bid Due Time: 10:00:00 AM

REPLY TO:

VENDOR INFO: \_\_\_\_\_  
 NAME: PROVIDE COMPANY NAME, ADDRESS, E-MAIL \_\_\_\_\_  
 CONTACT: \_\_\_\_\_  
 ADDRESS 1: \_\_\_\_\_  
 ADDRESS 2: \_\_\_\_\_  
 CITY: \_\_\_\_\_ STATE: \_\_\_\_\_ ZIP: \_\_\_\_\_  
 EMAIL: \_\_\_\_\_  
 PHONE: \_\_\_\_\_ FAX: \_\_\_\_\_

MONICA FOWLER  
 PURCHASING DEPARTMENT  
 Grand River Dam Authority  
 226 W DWAIN WILLIS AVE  
 PO BOX 409  
 VINITA OK 74301  
 PHONE: 405-297-9963 x4650  
 FAX: 405-840-1390  
 EMAIL: mfowler@grda.com

- NOTE: 1.The bid opening date for this RFQ is April 24, 2013 at 10:00 am Central Time.
- 2.A completed non-collusion certificate is required and must be submitted with your bid.
- 3.This form must be signed by an authorized representative of your company in the space provided in the lower right hand corner of this form.
- 4.The award to the successful bidder will be based on the lowest and best bid received that meets the specifications listed below and the requirements herein. Preference may be given to E-pay vendors if analysis estimates that such appears to result in a lower cost to GRDA.
- 5.The brand names, model(s), part number(s) provided herein are for comparable quality and identification purposes only and equivalent bids may be submitted.

Bidders should list the cost to provide these units by

- 1) June 1, 2013, and
- 2) by the bidder's optimum delivery date.

Bidders should specify their optimum delivery date in their bid response.

\*\*\*\*\* Read the General Bidding Instructions attached to this RFQ for further instructions.\*\*\*\*\*

**GRDA Visa Payment**

GRDA provides a Visa payment program which invoices payment by a secure Visa account number assigned to the supplier after award of contract. Notification of payments and required invoice information are issued to your designated Accounts Receivable contact by e-mail remittance payment.

Preference may be shown during the evaluation process to bidders that agree to accept the Visa payment of invoices. To learn more about the benefits of the Visa payment program, and to obtain answers to FAQ, click or copy and paste the following URL into your browser: [www.bankofamerica.com/epayablesvendors](http://www.bankofamerica.com/epayablesvendors).

Will accept payment by Visa: Yes \_\_\_\_ No \_\_\_\_ (check one)

Visa acceptance signature: \_\_\_\_\_

Designated Accounts Receivable Contact for Visa remittance advices:

Name: \_\_\_\_\_

Phone: \_\_\_\_\_

Email: \_\_\_\_\_

LINE ITEM	DESCRIPTION	NUMBER OF UNITS	UNIT OF MEASURE	UNIT PRICE	LINE COST	LEAD TIME
1	69kV Metering PT/CCVT stand. Per attached steel	2.0				

LINE ITEM	DESCRIPTION	NUMBER OF UNITS	UNIT OF MEASURE	UNIT PRICE	LINE COST	LEAD TIME
-----------	-------------	-----------------	-----------------	------------	-----------	-----------

drawing, (S612PS01) and per attached spec. TAG: Beggs Substation (RF011-00474)

1. Unit Price for delivery by June 1, 2013

Line Cost for delivery by June 1, 2013

2. Unit Price for delivery by the bidder's optimum date.

Line Cost for delivery by the bidders optimum date.

Bidders optimum delivery date

2	69kV CT stand. Per attached steel drawing, (S612PS02) and per attached spec. TAG: Beggs Substation (RF011-00474)	2.0				
---	--	-----	--	--	--	--

1. Unit Price for delivery by June 1, 2013

Line Cost for delivery by June 1, 2013

2. Unit Price for delivery by the bidder's optimum date.

Line Cost for delivery by the bidders optimum date.

Bidders optimum delivery date

*NOTE: All prices must be quoted FOB: Destination. All freight charges to delivery point must be included in the unit price quoted for each line item. All packaging, handling, delivery and any other surcharges must also be included in the price quoted for each line item.*

PAYMENT TERMS: \_\_\_\_\_

QUOTE EXPIRATION DATE: \_\_\_\_\_

QUOTATION NUMBER: \_\_\_\_\_

QUOTED BY (please print): \_\_\_\_\_

SHIP TO: Grand River Dam Authority  
TRANSMISSION & ENGINEERING HDQTRS  
635 HWY 69A  
PRYOR OK 74362

COMPANY NAME: \_\_\_\_\_

SIGNATURE: \_\_\_\_\_

DATE OF QUOTE: \_\_\_\_\_

**THIS IS NOT AN ORDER.** We would be pleased to receive your quotation for furnishing the above. This form must be completed **in full** (including signature) and returned by the due date above. You may attach additional pages if necessary. If attached, the Non-Collusion form must be completed and returned with your quotation. **NO PARTIAL SHIPMENTS OR PARTIAL PAYMENTS WILL BE ALLOWED WITHOUT PRIOR APPROVAL.**

All articles purchased hereunder shall be in accordance with the Bidding Procedures and General Terms & Conditions contained on the attached sheets.



GRAND RIVER DAM AUTHORITY

# NON-COLLUSION CERTIFICATE

RFQ / RFP # \_\_\_\_\_

**A Non-Collusion Certificate shall be included with any competitive bid or contract submitted to the Authority for goods or services exceeding \$5,000.00 (but not exceeding \$50,000.00), with the exception of those for the purpose of repairs and improvements to GRDA facilities.**

A. For purposes of competitive bid or contract, I certify:

1. I am the duly authorized agent of \_\_\_\_\_, (Company Name)  
the bidder submitting the competitive bid which is attached to this statement, for the purpose of certifying the facts pertaining to the existence of collusion among bidders and between bidders and state officials or employees, as well as facts pertaining to the giving or offering of things of value to government personnel in return for special consideration in the letting of any contract pursuant to said bid;
2. I am fully aware of the facts and circumstances surrounding the making of the bid to which this statement is attached and have been personally and directly involved in the proceedings leading to the submission of such bid; and
3. Neither the bidder, nor contractor, nor anyone subject to the bidder's or contractor's direction or control, has been a party:
  - a. to any collusion among bidders in restraint of freedom of competition by agreement to bid at a fixed price or to refrain from bidding,
  - b. to any collusion with any state official or employee as to quantity, quality or price in the prospective contract, or as to any other terms of such prospective contract, nor
  - c. in any discussions between bidders and any state official concerning exchange of money or other thing of value for special consideration in the letting of a contract, nor, whether competitively bid or not, has paid, given or donated or agreed to pay, give or donate to any officer or employee of the State of Oklahoma any money or other thing of value, either directly or indirectly, in procuring this contract herein.

B. The contractor further certifies that no person who has been involved in any manner in the development of said contract while employed by the State of Oklahoma shall be employed to fulfill any of the services provided for under said contract.

C. If any contract pursuant to this bid is for professional services as defined in 74 O.S. § 85.2.25, and if the final product is a written proposal, report or study, the contractor further certifies that (s)he has not previously provided the state agency or any other state agency with a final product that is a substantial duplication of the final product of the proposed contract.

\_\_\_\_\_  
*Authorized Signature*

\_\_\_\_\_  
*Certified this Date*

\_\_\_\_\_  
*Printed Name*

\_\_\_\_\_  
*Title*

\_\_\_\_\_  
*Telephone Number*

\_\_\_\_\_  
*Fax Number*

\_\_\_\_\_  
*E-Mail*

**Grand River Dam Authority is an agency of the State of Oklahoma.  
Administrative Headquarters • 226 West Dwain Willis Avenue • Vinita, Oklahoma 74301 • 918-256-5545**

# GENERAL BIDDING INSTRUCTIONS FOR STANDARD & EMERGENCY BIDS

1. Bids shall be submitted to the designated purchasing agent at the Grand River Dam Authority (hereinafter referred to as "GRDA" or "the Authority") at the address on the attached RFQ or RFP form on or before the date (and time, if applicable) indicated. Bids shall be in conformity with these and any additional instructions to bidders and shall be submitted on GRDA's form. **The RFQ (Request for Quote) or RFP (Request for Proposal) form must be completed in full and signed by the bidder.** If your bid response necessitates additional space, you may attach additional pages; however, the RFQ or RFP form must be completed, signed and reference the additional pages. All bid responses shall be typewritten or handwritten in ink, and any corrections to bids shall be initialed in ink. Quotations or proposals submitted in pencil shall not be accepted.
2. Quotations or proposals may be submitted to GRDA via postal mail, delivery service, fax or e-mail, provided all required signatures can be transmitted successfully.
3. **Non-Collusion Certificate:** RFQs or RFPs anticipated to exceed a total amount of \$5,000 shall be accompanied by a Non-Collusion Certificate. This certificate shall be completed by the bidder and include a signature in ink of an authorized company representative (preferably the bidder) with full knowledge and acceptance of the bid proposal. In the case of bids submitted via fax or e-mail, the Non-Collusion Certificate may be submitted with the bid. Purchase orders in excess of \$5,000 will not be released to the successful bidder without receipt of a properly signed certificate for the bid.
4. In the event the unit price and line total extension do not agree, the unit price shall be considered the quoted price accepted for evaluation.
5. **Freight Terms:** All prices shall be quoted FOB: Destination/Freight Allowed. All packaging, handling, shipping and delivery charges shall be included in the unit price quoted for each line item. No exceptions shall be granted unless approved by the guidelines of the GRDA Chief Financial Officer or designee.
6. **Other Surcharges:** Any additional surcharges (such as HazMat charges, fuel surcharges, set-up fees, etc.) shall be included in the unit price quoted for each line item. All additional charges are considered a part of the cost of the goods, and bids shall be evaluated to include these additional charges.
7. **Tax-Exempt Status:** GRDA is an agency of the state of Oklahoma and is specifically exempt from the payment of sales tax by Oklahoma state statute, Title 68 O.S.A. § 1356 (10). An excerpt from the statute shall be furnished upon request.
8. **Questions arising during the bidding process should be submitted in writing to the GRDA purchasing agent named on the RFQ or RFP.** The GRDA purchasing agent shall coordinate a reply from the end user to ensure that all potential bidders are provided the same information. Under no circumstances shall a bidder discuss pricing with any GRDA employee prior to the bid opening.
9. All bids submitted shall be subject to GRDA's Purchasing Policy and Procedures, General Terms and Conditions, the bidding instructions and specifications, the Oklahoma Open Records Act, other statutory regulations as applicable, and any other terms and conditions listed or attached herein – all of which are made part of this Request for Quote or Request for Proposal.
10. GRDA reserves the right to reject any and all bids, and to contract as the best interests of the Authority may require. GRDA reserves the right to reject any bids that do not comply with the requirements and specifications of the Request for Quote or Request for Proposal. All bid responses become the property of GRDA and are subject to the Oklahoma Open Records Act. GRDA shall endeavor to protect technical information designated by the bidder as proprietary information; however, only technical information (i.e., "trade secrets") may be considered proprietary – pricing and other non-technical aspects of the quote shall be considered non-proprietary.
11. **"Sole Brand" or "No Sub" Items:** Items with a "Sole Brand" or "No Sub" designation in the description shall be furnished as the specified manufacturer and model/part number. No exception may be taken to the specification, and no alternate shall be accepted. In those cases where a manufacturer has discontinued the specified model/part number, the bidder shall indicate so on the RFQ. If a replacement item is available, the new model/part number shall be indicated on the RFQ form and the price quoted. It shall also be noted whether the replacement item is a direct replacement for the obsolete part number originally requested. If not, or if the specifications differ in any way, the bidder shall explain in detail, and corresponding drawings or descriptive literature shall be included with the quote.

12. **Approved Equivalents:** Unless an item is designated as a “Sole Brand” or “No Sub” item, any manufacturer’s name, brand name, information and/or catalog number listed in a specification is for informational or cross-reference purposes and is not intended to limit competition. Bidders may offer any brand/manufacturer for which they are an authorized representative, provided it meets or exceeds the specification of the listed item. However, if quoting an equivalent product, bidders shall indicate on the RFQ form the manufacturer’s name and part number. Bidder shall also submit any drawings, descriptive literature and specifications for evaluation purposes. Reference to literature submitted with a previous bid shall not satisfy this provision. The bidder shall also provide written confirmation that the proposed equivalent will meet the requested specifications and is not considered an exception. Bids which do not comply with these requirements may be rejected. GRDA warehouses are not permitted to accept any item with a part number differing from that quoted by the bidder. Bids lacking any written indication of intent to furnish an alternate brand, model or part number shall be considered to be in complete compliance with the specifications as listed on the RFQ.
13. **Insurance Certificates:** Any service to be performed that requires the vendor’s employee, vehicle or equipment to be on any GRDA property must be covered by minimum insurance requirements. The workscope to be performed for the Authority shall be evaluated and the minimum insurance requirements shall be provided to prospective bidders with the RFQ or RFP. Evidence of insurance coverage shall be furnished in the form of a Certificate of Insurance, and shall be submitted with the bid response. Bidders shall disclose any subcontractors to be used, and the Authority shall consider the supplier as the single point of contact. The supplier shall assume responsibility for the performance of the subcontractor. Policies shall remain current for the duration of the requested service period, and GRDA shall be notified of any cancellation or revision to policies. Purchase Orders shall not be released to the successful bidder without a current Certificate of Insurance naming GRDA as certificate holder on file. A Memorandum of Insurance shall not be acceptable for this requirement.
14. **MSDS:** Material Safety Data Sheets shall be furnished to GRDA’s Safety Department at the address noted on the PO prior to delivery of items.
15. **Purchase Orders** shall be awarded to the “lowest and best” or “best value” bidder. Line items may be split into multiple orders, taking low items from each respective bidder, or orders may be awarded on an “all or none” basis, whichever is in the best interests of the Authority. Award decisions are further subject to consideration of any additional terms and conditions contained in the bid proposal. Vendor protests must be submitted in writing to the Central Purchasing Unit of GRDA within thirty-six (36) hours of award of Contract or Purchase Order.
16. Successful vendor shall deliver the merchandise or perform the service as quoted. Substitutions or changes without prior approval of the GRDA purchasing agent shall be rejected and returned at the vendor’s expense.
17. **Bidder Responsibilities:** Bidders are to transact all phases of the purchasing function directly with the GRDA purchasing agent. Bidders are to conduct all written and verbal communication with the Authority through the GRDA purchasing agent. Bidders are to conduct negotiations ethically, without attempts to influence through offers of valuable personal gifts or entertainment. Bidders are to make available as requested any technical information which might be of benefit in the bid evaluation.
18. **Supplier List:** The Finance Department maintains a current listing of suppliers with a cross-reference as to products and services offered. Suppliers may have their names added to the list by submitting a completed Vendor Registration/Payee Application, and shall notify the Authority of any update information. If a supplier fails to respond to bid requests after four appropriate solicitations, that supplier may be removed from the active list. Suppliers who do not meet quoted shipping dates or lead times, supply products or services of poor quality, substitute items of unequal quality, continually over-ship or under-ship items, or do not invoice properly may be placed under suspension or disqualified from the active supplier list. Suppliers may voluntarily request to be removed from the supplier database.
19. **Service Contracts:** By submitting a bid for services, the bidder certifies that they, and any proposed subcontractors, are in compliance with 25 O.S. §1313 and participate in the Status Verification System. The Status Verification System is defined in 25 O.S. §1312 and includes, but is not limited to, the free Employment Verification Program (E-Verify) available at [www.dhs.gov/E-Verify](http://www.dhs.gov/E-Verify). This shall remain in effect through the entire term, including all renewal periods, of the contract. The State may request verification of compliance for any contractor or subcontractor. Should the State suspect or find the contractor or any of its subcontractors are not in compliance, the State may pursue any and all remedies allowed by law, including, but not limited to: suspension of work, termination of the contract for default, and suspension or debarment of the contractor. All costs necessary to verify compliance are the responsibility of the contractor.

# GENERAL TERMS AND CONDITIONS



Any contract or order issued by the Grand River Dam Authority (hereinafter referred to as GRDA) is expressly conditioned upon Seller's assent to these terms and conditions, unless otherwise agreed in writing. Any order issued or filled by Seller shall be deemed to constitute Seller's assent to these terms and conditions. Any additional or different terms submitted by the Seller are hereby expressly objected to by GRDA unless expressly agreed to in writing by GRDA.

1. Mail or deliver all invoices or correspondence pertaining to the payment of this Purchase Order to: Accounts Payable Department, Grand River Dam Authority, P.O. Box 409, 226 West Dwain Willis Avenue, Vinita, Oklahoma 74301. Seller shall submit invoices, with one copy detailing each item with unit prices, with the top copy being distinguishable as an original, accompanied by one copy of complete shipping papers. If shipment is not made by routing instructions as specified on the face of this Purchase Order, GRDA reserves the right to deduct any excess transportation charges resulting therefrom. Copy of original freight bill must be supplied for payment. Time, in connection with any discount offered, will be computed from date of delivery of items, or from date the correct invoice is received in Vinita, Oklahoma, whichever period of time is the later date. No Oklahoma State Sales or Use Tax shall be included in payment of this Purchase Order.
2. All articles, materials, equipment and supplies (hereinafter referred to as "items") covered by this Purchase Order, unless otherwise specified, are purchased subject to inspection before and during manufacture and upon arrival at destination. GRDA reserves the right to return for full credit and/or refund, at Seller's sole risks and expense, including all transportation and storage charges, all items found defective or furnished contrary to instructions and/or specifications contained herein.
3. In case of default by Seller, GRDA may procure the items or services from other sources and hold Seller responsible for any excess cost occasioned thereby; provided, that if necessity requires the use of items not conforming to specifications, they may be accepted, and payment made at a proper reduction in price. Notwithstanding anything herein to the contrary, GRDA reserves the right to terminate this Purchase Order for its convenience. In the event of such termination, GRDA shall pay and Seller shall accept the reasonable value of all work performed and items delivered by Seller up through the effective date of such termination.
4. Seller warrants that all items covered by this Purchase Order will conform to the specifications, drawings, samples or other description furnished by GRDA, or any revisions thereof, and any items purchased pursuant to this Purchase Order shall be subject to all warranties expressed or implied by law, and will be merchantable of good material and fit and sufficient for the purpose intended, and shall satisfy any performance guarantee requirements as specified herein by GRDA. In the event the items and/or services purchased hereunder do not meet the warranty specified hereinabove, Seller shall promptly repair or replace any defective item at its expense, or re-perform any necessary services, and shall hold GRDA harmless from any and all costs and expenses incurred due to said defective item or performance of services, including the cost for removing any part or product to be repaired or replaced, as well as transportation and installation charges in connection with the repair, replacement or servicing of any parts or equipment. Seller further agrees that the manufacturer's warranties and guaranties of the items purchased hereunder extended to Seller shall extend to GRDA.
5. Seller shall indemnify and hold GRDA harmless from and against any and all loss, costs or expenses arising out of any liens or claims in any way related to the items or services furnished hereunder. Seller shall likewise indemnify and hold GRDA harmless from any patent, trademark or copyright infringement, except items supplied in accordance with design originating with GRDA. Seller shall be an independent contractor. Seller shall protect, defend, indemnify and hold GRDA harmless from any damage or injury to any persons, including Seller's employees or property, and from any claim, demand, action, cost or expense arising out of the activities hereunder as a result of Seller's negligent or intentional wrongful acts. In no event shall Seller's liability be limited under this Purchase Order for the negligent or intentional wrongful acts of the Seller.
6. Seller shall, before any items are shipped and/or any services are commenced, provide GRDA with certificates evidencing that the following minimum insurance will remain in force until Seller's obligations are completed: (a) Workmen's Compensation Insurance, including Employer's Liability Insurance, in accordance with the laws of the state in which Seller may be required to pay compensation; and (b) Public Liability Insurance with an individual limit of not less than \$100,000 and a total for any one accident of not less than \$300,000, unless otherwise specified herein.
7. This Purchase Order (including Seller's right to receive payments hereunder) shall not be assigned or subcontracted in whole or in part without GRDA's prior written consent. No assignment hereof shall relieve this assignor of its obligations hereunder.
8. Service Contracts: By submitting a bid for services, the Bidder certifies that they, and any proposed Subcontractors, are in compliance with 25 O.S. §1313 and participate in the Status Verification System. The Supplier/Contractor/Consultant/Construction Manager/etc. certifies that it and all proposed Subcontractors, whether known or unknown at the time a contract is executed or awarded, are in compliance with 25 O.S. §1313 and participate in the Status Verification System. The Status Verification System is defined in 25 O.S. §1312 and includes, but is not limited to, the free Employment Verification Program (E-Verify) available at [www.dhs.gov/E-Verify](http://www.dhs.gov/E-Verify). This shall remain in effect through the entire term, including all renewal periods, of the Contract. The State may request verification of compliance for any Contractor or Subcontractor. Should the State suspect or find the Contractor or any of its Subcontractors are not in compliance, the State may pursue any and all remedies allowed by law, including, but not limited to: suspension of work, termination of the Contract for default, and suspension or debarment of the Contractor. All costs necessary to verify compliance are the responsibility of the Contractor.
9. All Items shipped pursuant to this Purchase Order will conform with all municipal, state and federal laws, ordinances and regulations, and Seller will defend and save harmless GRDA from loss, costs or damage by reason of any actual or alleged violation thereof.
10. GRDA hereby notifies Seller that Seller must comply, and by acceptance of this Purchase Order, Seller represents that it has complied with, and will continue to comply with, all applicable federal, state and local laws, regulations or orders.
11. This Purchase Order shall be construed as being performed by both parties in Craig County, Oklahoma, and shall be governed in accordance with the laws of the State of Oklahoma.

*Grand River Dam Authority is an agency of the State of Oklahoma.*

**Administrative Headquarters • 226 West Dwain Willis Avenue • Vinita, Oklahoma 74301 • Phone: 918-256-5545 • Fax: 918-256-1051**

# **GRAND RIVER DAM AUTHORITY**

## **SUBSTATION STEEL STRUCTURES**

### **TECHNICAL SPECIFICATIONS**

#### Table of Contents

- 1 Scope
- 2 Definitions
- 3 References
- 4 Design Conditions
- 5 Performance Criteria
- 6 Deflections
- 7 Drawings and Calculations
- 8 Materials
- 9 Fabrication
- 10 Protective Coatings
- 11 Quality Assurance
- 12 Shipping Requirements
- 13 Guarantee
- 14 Documentation
- 15 Acceptance of equipment
- 16 Terms of payment and conditions
- 17 Evaluation of Bids

# GRAND RIVER DAM AUTHORITY

## SUBSTATION STEEL STRUCTURES

### TECHNICAL SPECIFICATIONS

#### 1 SCOPE

- 1.1 This specification states the minimum requirements for the design conditions, performance criteria, deflections, drawings and calculations, materials, fabrication, protective coatings, quality assurance and shipping requirements for low-profile tapered-tubular steel substation structures. Loading and configuration information shall supplement this specification. GRDA does not necessarily provide 'shop ready' drawings. It is the responsibility of the vendor to verify the design to the loading information and generate any needed shop drawings from the drawings provided.

#### 2 DEFINITIONS

- 2.1 Purchaser – GRDA or GRDA's authorized representative purchasing low-profile tapered-tubular steel substation structures.
- 2.2 Fabricator – Company supplying low-profile tapered-tubular steel substation structures.
- 2.3 NEMA Class A Structure – Class "A" structures are those intended for the support of high-voltage equipment (i.e., air switches, interrupter switches, and circuit interrupting devices).
- 2.4 NEMA Class B Structure – Class "B" structures are those on which the deflections within the limits do not affect the performance of supported equipment (i.e., dead end structures, bus supports and miscellaneous equipment supports).
- 2.5 Stress Critical Structure – A structure where the design is typically controlled by stress, is tension loaded or is subject to cyclic loading.
- 2.6 Deflection Critical Structure – A structure where the design is typically controlled by Deflection.
- 2.7 Joint Penetration – A measurement from the surface of the parent material to the weld root.
- 2.8 Inspection and Test Plan – A written procedure defining hold points, for inspecting and testing methods.
- 2.9 Component – An item or sub-assembly designated for field installation.
- 2.10 Equipment Cut-Sheets – Drawings of the equipment, which includes the equipment weight, center of gravity, wind area and mounting footprint.



# GRAND RIVER DAM AUTHORITY

## SUBSTATION STEEL STRUCTURES

### TECHNICAL SPECIFICATIONS

#### 3 REFERENCES

3.1 Unless shown on the drawings, references may be made to the latest applicable revision of American National Standards Institute specifications as commonly used by domestic electric utilities. The following abbreviations shall be used:

Specification	Abbreviation	Reference
3.1.1	ASCE	American Society of Civil Engineers
3.1.1.1	ASCE 72	Design of Steel Transmission Pole Structures
3.1.2	NESC	National Electric Safety Code
3.1.3	NEMA	National Electrical Manufacturers Association
3.1.3.1	NEMA TT-1	Standard for Tapered Tubular Steel Structures
3.1.3.2	NEMA SG 6	Power Switching Equipment
3.1.4	AISC	Code of Standard Practice for Steel Buildings & Bridges
3.1.4.1	AISC ASD	Manual of Steel Construction – Allowable Stress Design
3.1.5	AWS	American Welding Society
3.1.5.1	AWS D1.1	Structural Welding Code - Steel
3.1.6	ACI	American Concrete Institute
3.1.6.1	ACI 318-83	Building Code Require. for Reinforced Concrete, 1983
3.1.7	IEEE	Institute of Electrical & Electronic Engineers
3.1.8	UBC	Uniform Building Code
3.1.9	ASNT	American Society of Nondestructive Testing
3.1.10	ASTM	American Society for Testing & Materials
3.1.11	ANSI	American National Standards Institute

#### 4 DESIGN CONDITIONS

4.1 As a minimum, the following conditions shall be used for structure design.

4.1.1 ICE + WIND: The structure is to be loaded with all equipment, structure dead weight and a coating of radial ice on both equipment and structure. The degree of loading due to ice shall be considered as light, medium, or heavy in accordance with the geographical areas shown in the loading map in ANSI C2, Part 2, Section 250. A wind pressure will be applied to the ice-coated equipment and to the structure. The wind speed will be 80 miles per hour.

# GRAND RIVER DAM AUTHORITY

## SUBSTATION STEEL STRUCTURES

### TECHNICAL SPECIFICATIONS

- 4.1.2 EXTREME WIND: The structure is to be loaded with all equipment and structure dead weight without ice. A wind pressure shall be applied to the equipment and structure. The extreme wind speed will be 100 miles per hour.
- 4.1.3 SEISMIC: Where applicable, the structure is to be loaded with all equipment and structure dead weight without ice or wind. Seismic loading shall be applied to the equipment and structure as recommended by UBC.
- 4.1.4 SHORT CIRCUIT: A horizontal force, equal to 100% of the rated cantilever strength of the insulator, shall be applied perpendicular to the rigid bus at the top of the insulator. No horizontal or vertical forces from wind, ice or seismic shall be considered on bus or equipment. Short circuit reactions plus extreme wind shall be applied to the structure.
- 4.2 WIND PRESSURE
- 4.2.1 Calculate wind pressure as follows:  $P = 0.00256 \times V^2 \times C_d$   
Where: P = Wind pressure in pounds per square foot  
V = Wind velocity in miles per hour  
Cd = Drag coefficient:  
1.0 for 12 or more sided surfaces  
1.3 for 8 or 6 sided surfaces  
1.6 for flat surfaces
- 4.2.2 Apply the wind in the most severe direction. Investigate a diagonal wind load for the design of anchor bolts. Wind shade factors are not allowed. Increase the wind profile of equipment by the radial ice thickness before calculating the wind load.
- 4.3 ICE LOAD
- 4.3.1 To account for the increase in equipment and structure weight due to ice, multiply the dead weight of the equipment and structure by these factors:  
¼ in. – use 1.25                      ½ in. – use 1.50
- 4.4 RIGID BUS
- 4.4.1 Unless otherwise shown on the drawings, round aluminum bus, schedule 40, of the following diameter and span length will be assumed:
- |                        |                                 |                     |                     |
|------------------------|---------------------------------|---------------------|---------------------|
| Equipment Voltage (kV) | <u><math>\geq 345</math> kV</u> | <u>230 to 161kV</u> | <u>138 to 15 kV</u> |
| Bus Diameter (in.)     | 6                               | 4                   | 3                   |
| Bus Span (ft.)         | 50                              | 40                  | 30                  |
- 4.5 WIRE LOAD
- 4.5.1 Unless shown on the drawings, terminate wires on structures at a horizontal line angle of +/-15 degrees and at a vertical angle of 0 degrees.
- 4.5.2 Unless shown on the drawings, the initial wire tension for design shall be 15,000 lbs./wire.

# GRAND RIVER DAM AUTHORITY

## SUBSTATION STEEL STRUCTURES

### TECHNICAL SPECIFICATIONS

- 4.5.3 Design for terminating wires on one side of the structure. Consider effects of wires terminated on both sides of the structure with transverse wind and maximum line angle.
  - 4.6 EQUIPMENT
    - 4.6.1 The Purchaser shall provide the Fabricator with the equipment classification.
    - 4.6.2 Unless shown on the drawings or Equipment Cut-Sheets, the rated cantilever strength shall be taken as the value assigned for a “Standard Strength” insulator.
  - 4.7 ANCHOR BOLTS
    - 4.7.1 Anchor bolts, furnished by the Fabricator, are considered as a part of the structure and shall be designed for leveling the structure.
    - 4.7.2 The distance from the top of the concrete to the bottom of the steel base plate shall be 1 inch plus one anchor bolt diameter.
    - 4.7.3 Grout shall not be applied between the top of concrete and the bottom of steel.
    - 4.7.4 Bolt holes for anchor bolts shall be oversized  $\frac{1}{4}$ ” for anchor bolts less than and equal to  $\frac{3}{4}$ ” diameter. Bolt holes for anchor bolts shall be oversized  $\frac{5}{16}$ ” for anchor bolts greater than and equal to 1” diameter.
  - 4.8 SLIP JOINTS
    - 4.8.1 Slip joints shall not be used.
- 5 PERFORMANCE CRITERIA
- 5.1 STRESS
    - 5.1.1 For design conditions 4.1.1, 4.1.2 and 4.1.3, structural member stress shall remain below the allowable stress as defined by AISC ASD.
    - 5.1.2 For design condition 4.1.4, structural member stress shall not exceed the yield strength of the material or the allowable stress as defined by ASCE 72.
    - 5.1.3 Width to Thickness ratios or diameter to thickness ratios for tubular steel members shall be in accordance with the requirements set forth in ASCE 72.
    - 5.1.4 Computer aided analysis and design shall include secondary moments from non-Linear effects (p-delta) for structure stresses.
    - 5.1.5 Anchor bolts shall be long enough to transfer the foundation loads into the footing through bond stress.
      - 5.1.5.1 For design conditions 4.1.1, 4.1.2 and 4.1.3, smooth bar anchor bolts shall be designed with a bond stress of 50% of the value calculated in NEMA TT-1, Appendix A. Deformed bar anchor bolts shall be designed for bond stress at 60% of the value calculated by the ACI 318-83 (see ASCE 72).

# GRAND RIVER DAM AUTHORITY

## SUBSTATION STEEL STRUCTURES

### TECHNICAL SPECIFICATIONS

- 5.1.5.2 For design condition 4.1.4, smooth bar anchor bolts shall be designed with a bond stress calculated by NEMA TT-1, Appendix A. Deformed bar anchor bolts shall be designed for bond stress calculated by the ACI 318-83 (See ASCE 72).
- 5.1.5.3 Unless shown on the drawings, the compressive strength of concrete shall be 3000 psi.

## 6 DEFLECTIONS

6.1 For design condition 4.1.1, member deflections shall be limited as follows:

### 6.1.1 EQUIPMENT STAND – NEMA Class A Structure

<u>Horizontal members—with respect to their supports:</u>	<u>Vertical members—at equip. mounting elev.:</u>
Horizontal deflection – Span/200	Horizontal deflection – Height/100
Vertical deflection – Span/200	Angular deflection - 0.01 Radian
Angular deflection – 0.005 Radian	

### 6.1.2 EQUIPMENT STAND – NEMA Class B Structure

<u>Horizontal members – with respect to their supports:</u>	<u>Vertical members-at equip. mounting elev.:</u>
Horizontal deflection – Span/100	Horizontal deflection – Height/50
Vertical deflection – Span/200	Angular deflection – 0.02 Radian
Angular deflection – 0.005 Radian	

### 6.1.3 LINE TERMINATION STRUCTURE – NEMA Class A Structure

<u>Horizontal members supporting equipment – with respect to their supports:</u>	<u>Vertical members – at equip. mounting elevations:</u>
Horizontal deflection – Span/200	Horizontal deflection – Height/100
Vertical deflection – Span/200	

6.1.4 Line termination Structures requiring both NEMA Class A and NEMA Class B limits shall meet Class A limits at Class A equipment elevation and Class B limits for elevations above those equipment mounting elevations.

### 6.1.5 LINE TERMINATION STRUCTURE & MASTS – NEMA Class B Structure

<u>Horizontal members-with respect to their supports:</u>	<u>Vertical members-with respect to the structure base:</u>
Horizontal deflection – Span/100	Horizontal deflection – Height/50
Vertical deflection – Span/200	

6.2 Do not apply deflection limits to design conditions 4.1.2, 4.1.3 or 4.1.4.

# GRAND RIVER DAM AUTHORITY

## SUBSTATION STEEL STRUCTURES

### TECHNICAL SPECIFICATIONS

#### 7 DRAWINGS AND CALCULATIONS

- 7.1 GRDA shall provide Equipment Cut-Sheets showing mounting hole dimensions with the purchase order, if they are available at the time of order.
- 7.2 Equipment mounting bolts are to be furnished by the GRDA. Anchor bolts and cages shall be furnished by the Steel Fabricator.
- 7.3 The Fabricator shall prepare detailed structure drawings for manufacturing and assembly purposes. These drawings shall include the following:
  - 7.3.1 Anchor bolt details and patterns
  - 7.3.2 Assembly and erection details
  - 7.3.3 Structure members, connections and equipment mounting details.
- 7.4 The Fabricator shall mail (1) set of design calculations and foundation loads, in accordance with the Purchase Order, to the GRDA Project Engineer (mailing address is listed later in this specification).
- 7.5 Approval and final drawings will be sent in accordance with the Purchase Order, to the GRDA Project Engineer e-mail address, as electronic media.
  - 7.5.1 If requested by the GRDA, paper or reproducible copies of approval and final drawings shall be transmitted to the GRDA Project Engineer's mailing address.
  - 7.5.2 The engineer assigned to review these drawings is: Edwin Averill, Project Engineer, e-mail: [baverill@grda.com](mailto:baverill@grda.com)
  - 7.5.3 The drawings are to be submitted in .pdf format for approval, and AutoCad for final drawings. Check with the engineer for the proper version of cad drawing.
- 7.6 Fabrication shall not begin until all drawings are marked "APPROVED" or "APPROVED AS NOTED" and have been returned to the Fabricator.

#### 8 MATERIALS

- 8.1 All steel materials shall conform to ASTM specifications, as required by design, and shall be suitable for use in welded and galvanized structures. The steel is to be manufactured in the United States. The vendor is to supply certification that the steel is manufactured by a domestic source in the US.

# GRAND RIVER DAM AUTHORITY

## SUBSTATION STEEL STRUCTURES

### TECHNICAL SPECIFICATIONS

- 8.2 Unless shown on the drawings, all steel material shall conform to one of these ASTM specifications:
- 8.2.1 STRUCTURES – A-36, A-53 Gr. B, A-500 Gr. B, A-572, A-588, A-595, A-633 Gr. E and A-871.
  - 8.2.2 ANCHOR BOLTS – A-36 bar with A-563 Gr. A nuts A-615 Gr. 75 (NORSCO 75S) deformed bar with A-194 Gr. 2H nuts.
  - 8.2.3 CONNECTION BOLTS – A-325 Type(s) I and III with Anco locknuts A-354 Gr. BC with Anco locknuts .
- 8.3 Steel that will receive a galvanized finish shall be limited in silicon content as follows:
- 8.3.1  $Si < 0.06\%$  or  $0.15\% < Si < 0.40\%$
  - 8.3.2 This limit is not available for A-500 Gr. B material.
- 8.4 Charpy “V” notch test qualifications shall be determined in accordance with ASTM A-370, A-673 and ASCE 72. These qualifications will not be required for A-36, A-53 Gr. B, A-500 Gr. B or A-595 materials.
- 8.5 Provide weld material that is compatible with the parent material, as defined by AWS D1.1. The weld material must meet the Charpy “V” notch test qualifications in this specification for the lowest toughness qualification of the plates being joined.

## 9 FABRICATION

- 9.1 Fabrication tolerances shall conform to the AISC, AWS D1.1. Fabrication shall be preformed in strict compliance with the shop detail drawings.
- 9.2 Stress Critical Structures shall meet the requirements of AWS D1.1, Section 9.
- 9.3 Deflection Critical Structures shall meet the requirements of AWS D1.1, Section 8.
- 9.4 Holes in plates may be punched, drilled or burned. All burned holes shall be done by machine-guided torch, no manual burning will be allowed.
- 9.5 Plates may be sheared or burned. All burning shall be done by machine-guided torch, no manual burning will be allowed.
- 9.6 The roughness of gas-cut surfaces shall not exceed the tolerance defined by AWS D1.1.
- 9.7 SPECIAL WELD CONSIDERATIONS
- 9.7.1 Shaft/Base plate or Shaft/Splice plate:
    - 9.7.1.1 The weld shall be 100% joint penetration for all Stress Critical structures.
    - 9.7.1.2 The weld shall be as required by design stress for all Deflection-Critical structures.

# GRAND RIVER DAM AUTHORITY

## SUBSTATION STEEL STRUCTURES

### TECHNICAL SPECIFICATIONS

- 9.7.2 All circumferential welds between shaft sections shall be 100% joint penetration.
- 9.7.3 Longitudinal Welds – Other than at a slip joint:
  - 9.7.3.1 The weld shall be 60% joint penetration in all materials  $\frac{3}{4}$ " thick or less.
  - 9.7.3.2 The weld shall be 80% joint penetration in all materials thicker than  $\frac{3}{4}$ ".
  - 9.7.3.3 The weld shall be 100% joint penetration for a minimum length of six inches from any base plate/splice weld or any circumferential weld requiring 100% joint penetration.
- 9.7.4 Longitudinal Welds – In Slip Joints:
  - 9.7.4.1 The weld at the end of the female section shall be 100% joint penetration for a minimum length equal to the slip joint design length plus six inches.
  - 9.7.4.2 The weld at the end of the male section shall be 100% joint penetration for a minimum length of six inches.
- 9.7.5 Other Welds:
  - 9.7.5.1 All other welds shall be fillet, bevel or a combination of both, as required by design.
- 9.8 Clearly mark components by stamping prior to galvanizing. Stamped marks shall be a minimum of  $\frac{1}{2}$ " high letters.
- 9.9 Perform welding using welders, welding operators and tackers in accordance with AWS D1.1.

## 10 PROTECTIVE COATINGS

- 10.1 All materials to be coated shall be completely fabricated prior to the coating process.
  - 10.1.1 Preparation and fabrication for galvanized structures shall be in accordance with ASTM A-385.
  - 10.1.2 Galvanize members in accordance with ASTM A-123.
  - 10.1.3 Safeguards against embrittlement shall be in accordance with ASTM A-143.
  - 10.1.4 A Magnetic Coating Thickness Gauge per ASTM E-376 shall measure the galvanized coating thickness.
  - 10.1.5 Repair damaged hot dip galvanized surfaces in accordance with A-780.
  - 10.1.6 Galvanize fasteners in accordance with ASTM A-153.
  - 10.1.7 Anchor bolts shall be galvanized the threaded length plus at least six inches.

# GRAND RIVER DAM AUTHORITY

## SUBSTATION STEEL STRUCTURES

### TECHNICAL SPECIFICATIONS

#### 11 QUALITY ASSURANCE

- 11.1 Inspection criteria shall be as defined in AISC, AWS D1.1.
- 11.2 Inspectors shall be qualified to ANSI recommended practice SNT-TC-1A.
- 11.3 All welding, welder certification and weld procedures shall meet the requirements of AWS D1.1
- 11.4 All material shall meet the certification requirements of AISC.
- 11.5 The Fabricator shall maintain a system, which allows verification of all materials meeting specified requirements.
- 11.6 Certified test reports shall be available, upon request by GRDA.
- 11.7 All cold-formed parts, in material over ½” thick, shall have the corners inspected along the entire length for cracks by a magnetic particle procedure. All discontinuities shall be repaired and re-inspected per the requirements of AWS D1.1.
- 11.8 All other formed parts shall be subjected to close visual inspection.
- 11.9 The Fabricator shall maintain an Inspection and Test Plan available for review by GRDA.
- 11.10 GRDA shall specify, in the Request for Quotation, any special inspection, load testing or pre-shipment assembly requirements.
- 11.11 The bidding company shall have on staff a licensed professional engineer to oversee the quality of completed product.

#### 12 SHIPPING REQUIREMENTS

- 12.1 All materials shall be shipped with distinct marks for positive identification at the site.
  - 12.1.1 The identification system will use component numbers as shown on the fabrication drawing submitted for approval.
  - 12.1.2 Every component shall be marked with the assembly number assigned to it in the fabrication drawings.
- 12.2 All materials shall be carefully loaded for protection during shipment.
  - 12.2.1 Small parts, lightweight components and fasteners shall be carefully boxed, crated or otherwise protected for shipment.
  - 12.2.2 Components requiring bundling shall be banded with rustproof strapping to prevent staining.
  - 12.2.3 All material shall be properly blocked on cars or trucks to prevent damage to the coating or distortion of members during transit.
  - 12.2.4 All material shall be arranged to allow safe unloading at the site.
- 12.3 Each shipment shall have a detailed packing list included, specific to that shipment. Each crate shall be labeled with the content of the crate.



# GRAND RIVER DAM AUTHORITY

## SUBSTATION STEEL STRUCTURES

### TECHNICAL SPECIFICATIONS

12.4 All shipments shall be made to:

Grand River Dam Authority  
4.5 miles East on Hwy 69A  
Pryor, Oklahoma 74362

GRDA may provide an alternate shipping location with the Purchase Order.

12.5 GRDA shall be provided with a 48 hour (week day) pre-delivery notification by the fabricator. Notification shall be to:

Edwin Averill, Project Engineer  
Phone: 918-824-7843

Or

Mike Ragsdale, Warehouse  
Phone: 918-824-7850

## 13 GUARANTEE

13.1 The Fabricator shall furnish warranty for all materials and workmanship for a period of one (1) calendar year from the date of receipt against all defects due to faulty workmanship or materials and shall agree to replace same at no expense to GRDA.

## 14 DOCUMENTATION

14.1 The Fabricator shall provide one (1) CD copy and one (1) paper copy, per substation, of the final drawings.

14.2 All drawings will be generated using IBM compatible computers utilizing the Windows platform and using AutoCAD V. 2010 software by AutoDesk. Electronic copies of the final drawings in the DWG file format will be required.

14.3 Required documents shall consist of:

Bill of Material  
Steel Detail Drawings  
Steel Assembly Drawings

# GRAND RIVER DAM AUTHORITY

## SUBSTATION STEEL STRUCTURES

### TECHNICAL SPECIFICATIONS

#### Calculations

- 14.4 The address for all correspondence and drawing submittals is:

Jeff Tullis, Chief Engineer  
Grand River Dam Authority  
P.O. Box 1128  
Pryor, Oklahoma 74362-1128  
Email: [jtullis@grda.com](mailto:jtullis@grda.com)

Edwin Averill, Project Engineer  
Grand River Dam Authority  
P.O. Box 1128  
Pryor, Oklahoma 74362-1128  
e-mail: [baverill@grda.com](mailto:baverill@grda.com)

- 14.5 The address for shipment is:

Grand River Dam Authority  
4.5 miles East on Hwy 69A  
Pryor, Oklahoma 74362

- 14.6 All correspondence, documents, and shipments shall be labeled with the appropriate project name.

## 15 ACCEPTANCE OF EQUIPMENT

- 15.1 After delivery, the steel will be inspected by GRDA for visible damage, missing items, and signs of poor workmanship. Equipment or materials that are not acceptable shall be repaired, corrected, or replaced by the Fabricator at no additional cost to GRDA before the steel is accepted.
- 15.2 Acceptance does not occur until all equipment and documentation required by the specification and necessary to install the equipment is received by GRDA.
- 15.3 Acceptance of the equipment by GRDA does not relieve the Fabricator of the responsibility for the adequacy of materials and proper operation of equipment.

# GRAND RIVER DAM AUTHORITY

## SUBSTATION STEEL STRUCTURES

### TECHNICAL SPECIFICATIONS

#### 16 TERMS OF PAYMENT AND CONDITIONS

- 16.1 All proposals, bids, or quotations shall be FOB Destination.
- 16.2 No partial payments shall be made for partial shipments.
- 16.3 Conditions of the “Acceptance of Equipment” must be met before any payment will be made.

#### 17 Evaluations of Bids

- 17.1 Bids shall be evaluated based on the following:
  - Price: original cost and life cost (the bid may include an option for different prices for different delivery dates).
  - Delivery: as needed for the project
  - Suitability: ability to meet the needs of the project

The bid must include enough technical data and information to allow the evaluator to understand what is being bid, and how this meets the needs of the project.

Any and/or all exceptions shall be specifically enumerated with reference to the item in the specification that they are taking exception to. If these are not specifically listed, it will be assumed that the bidder will meet the specification, and will be held to it.

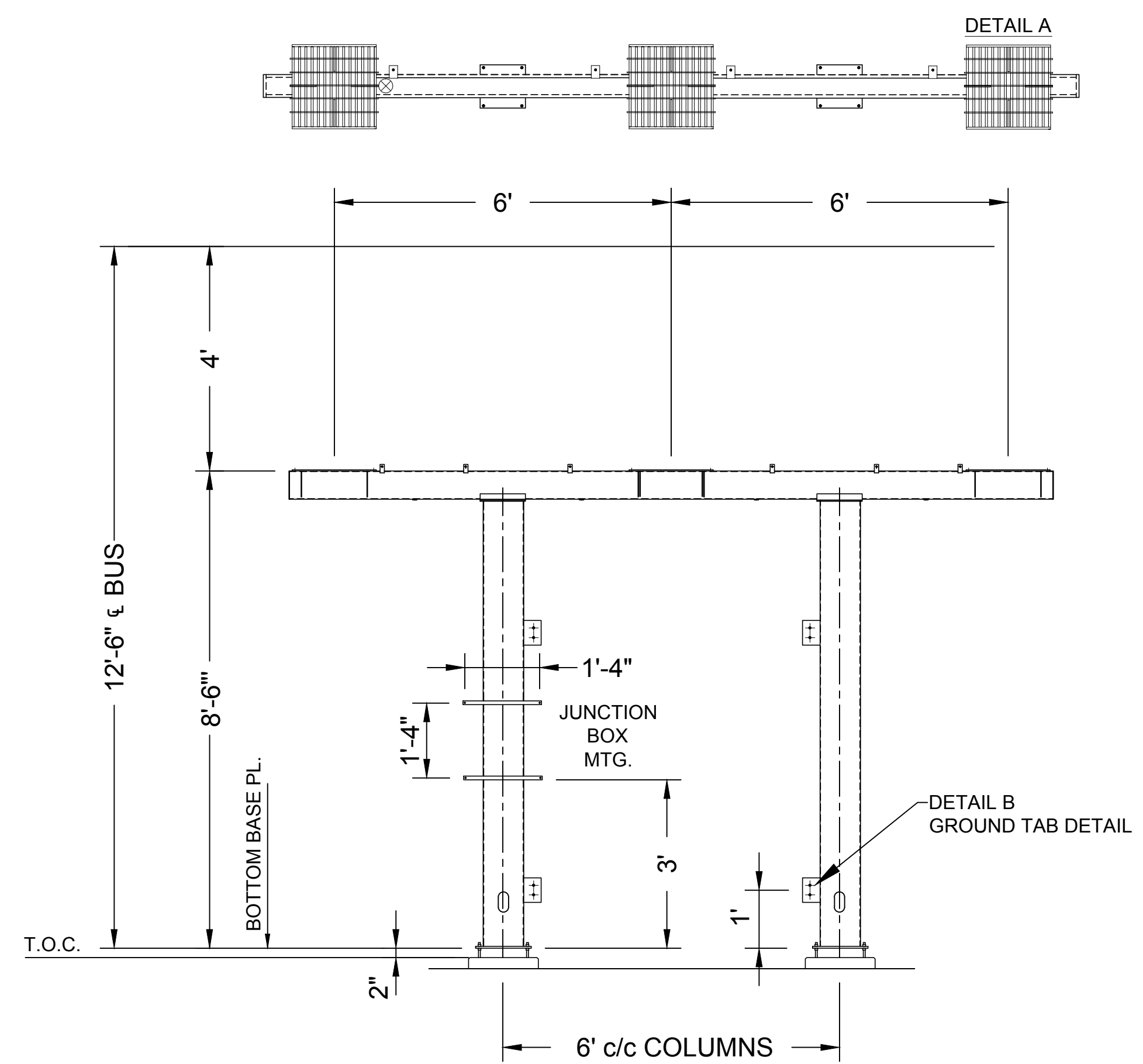

**69 kV 3-PHASE CT STAND**  
(2 REQUIRED)

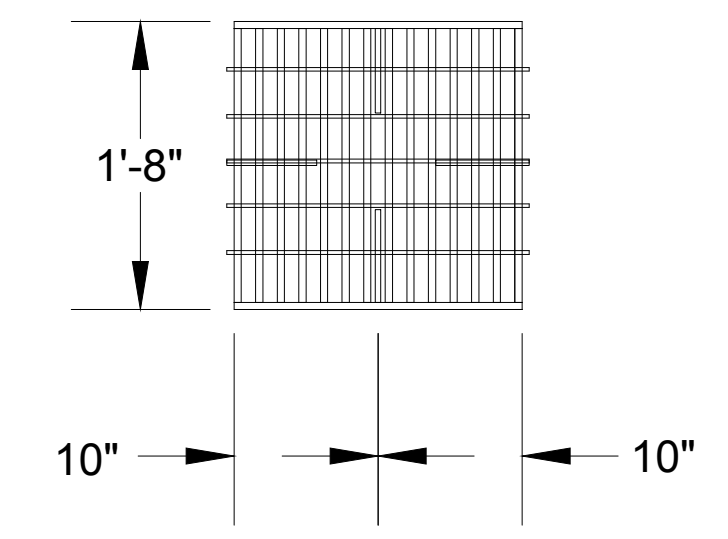

**DETAIL A**  
NOT TO SCALE

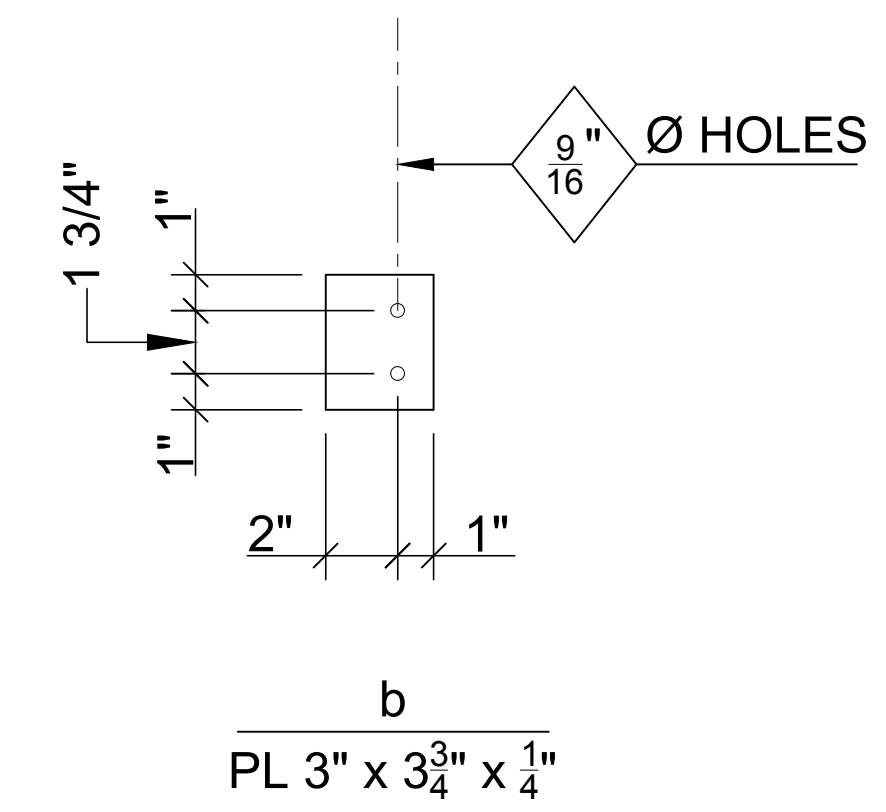

**DETAIL B**  
2-HOLE GROUND TAB DETAIL  
NOT TO SCALE

						GRAND RIVER DAM AUTHORITY <b>BEGGS SUBSTATION</b> S612 BEGGS, OKLAHOMA 69KV <b>69KV 3-PHASE CT STAND</b>			
CONTROL SYSTEM AND AMPACITY UPGRADE						SCALE: 1/2" = 1'-0"	DRAWN BY: AS	ENGR: RM	APPD: -
0	RFD11-00474	2/2013	RM	JT	RM	BA	CH: -	DATE: DMOY	
REV. NO.	JOB NO.	DATE	DESIGN ENGR	DFTR	DESIGN CHECK	ISSUE APPROVD	DRAWING No. <b>S612PS02</b>		
							REV. <b>0</b>		



MATERIAL FOR 1 STAND

MARK	REQ'D.	DESCRIPTION	LENGTH	REMARKS
CC	1	PL 3/16"x9x6(OCT.)	6'-10-3/4"	COUPLING CAPACITOR STAND
a	1	PL 3/4"x 16"	1'-4"	
b	1	PL 1/2"x 24"	2'-0"	
c	4	PL 1/2"x 5"	0'-7"	
d	1	PL 3/8"x 7 3/8"	1'-11/2"	BENT
e	1	PL 3/8"x 7 1/2"	1'-11/2"	BENT
f	1	PL 1/4"x 2 1/4"	0'-3 3/4"	GROUND PAD
g	1	PL 1/4" X 4"	1'-4"	BENT
h	2	PL 1/4" X 2"	0'-3 1/2"	

WEIGHT OF ONE STRUCTURE 338 LBS.  
(INCLUDING ANCHOR BOLTS)

NOTES

1. MATERIAL: A36
2. FINISH: GALV. A-123
3. UNLESS NOTED ALL WELDS TO BE CONTINUOUS FILLET WELDS 1/16" THINNER THAN THINNEST MATERIAL.
4. (2) REQUIRED FOR CCVT
5. (3) REQUIRED FOR PT

REFERENCE DRAWINGS

- S612PE01 PLAN VIEW
- S612PE03 SECTIONS "DD", "EE", "GG", "HH", "JJ", "KK"
- S612PE04 ELECTRICAL ELEVATIONS MM, NN & OO
- S612PG31 FOUNDATION DETAILS

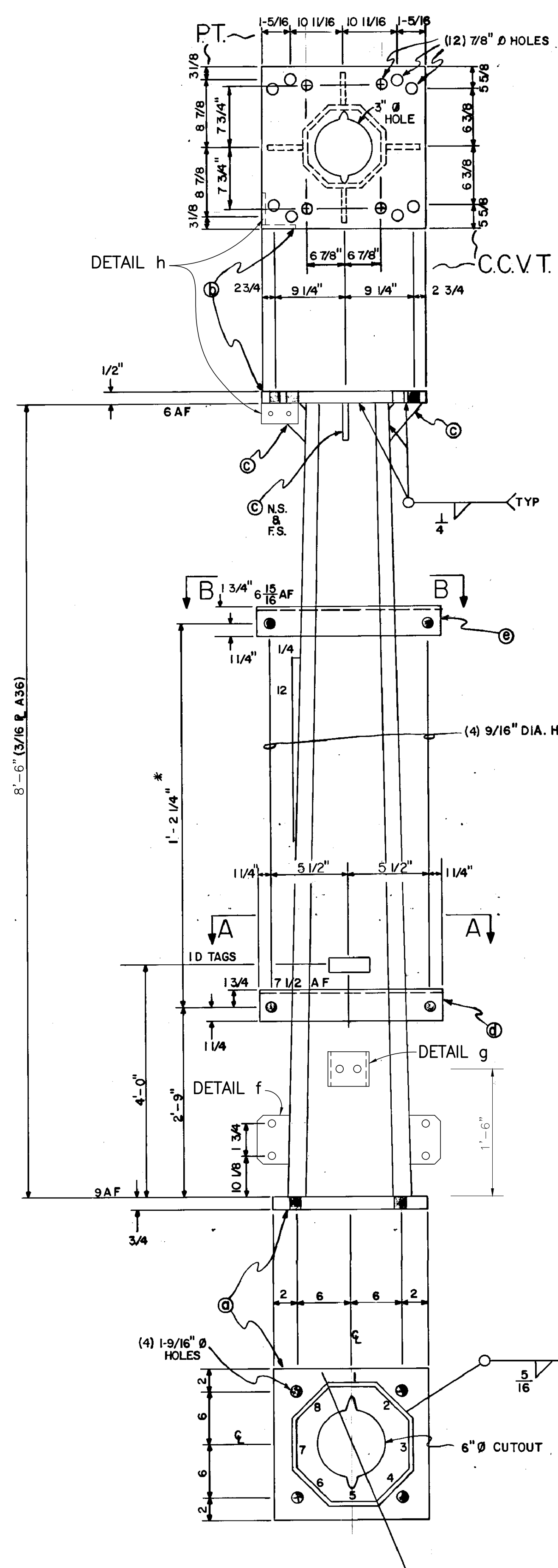

ONE POLE CC  
(2 REQUIRED)

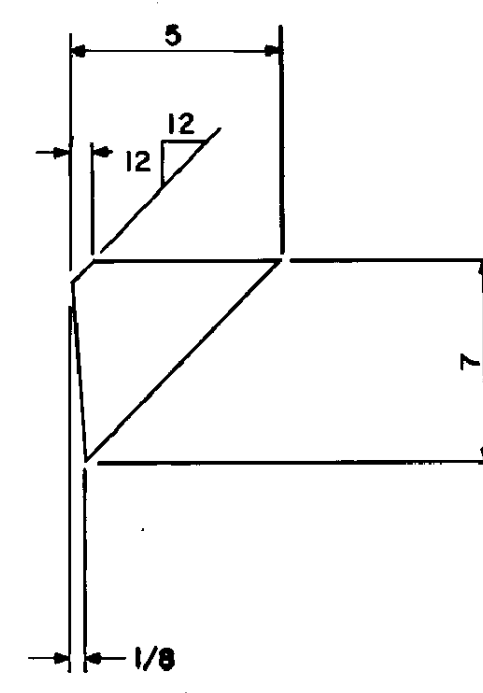

DETAIL-c

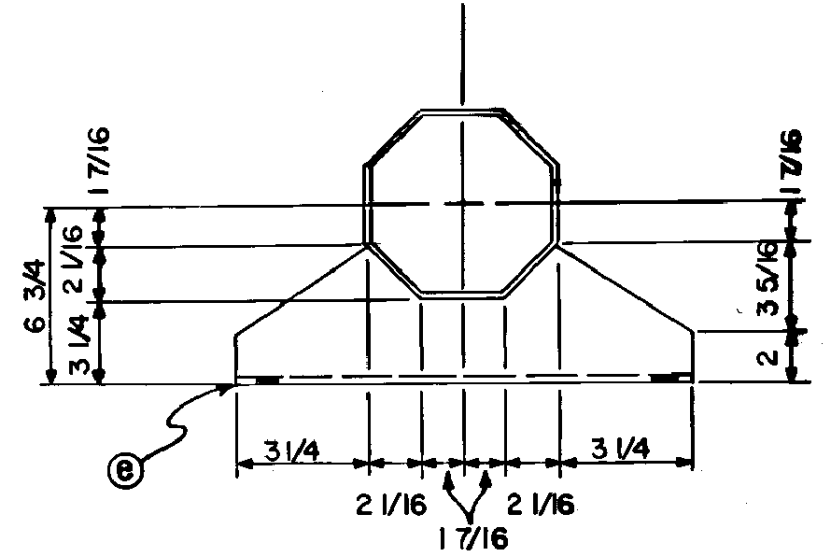

SECTION B-B

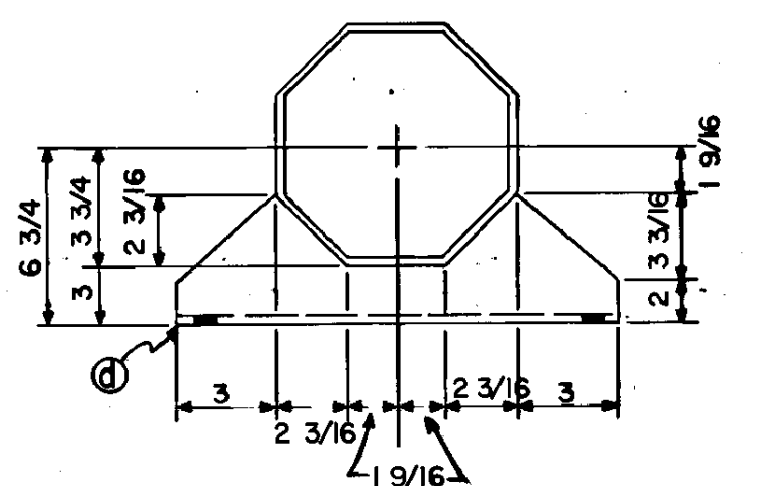

SECTION A-A

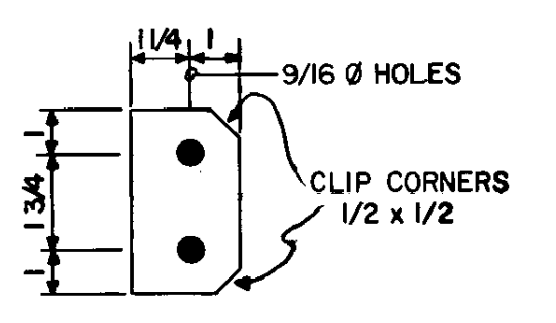

DETAIL f

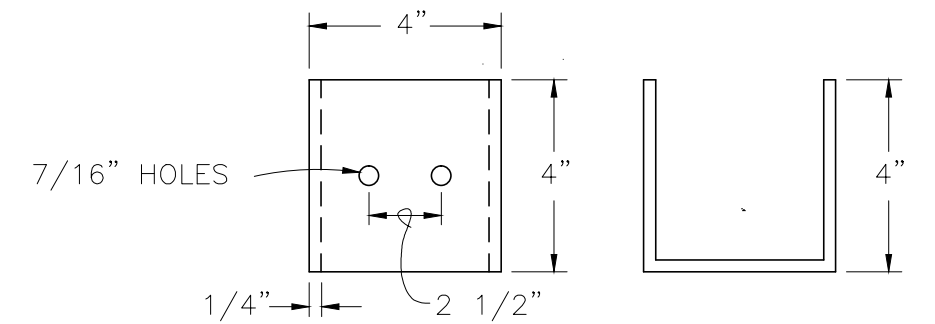

DETAIL g

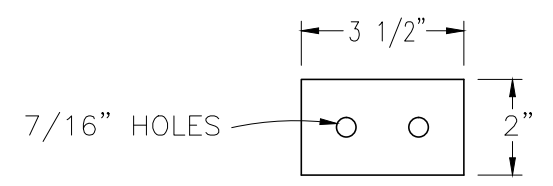

DETAIL h

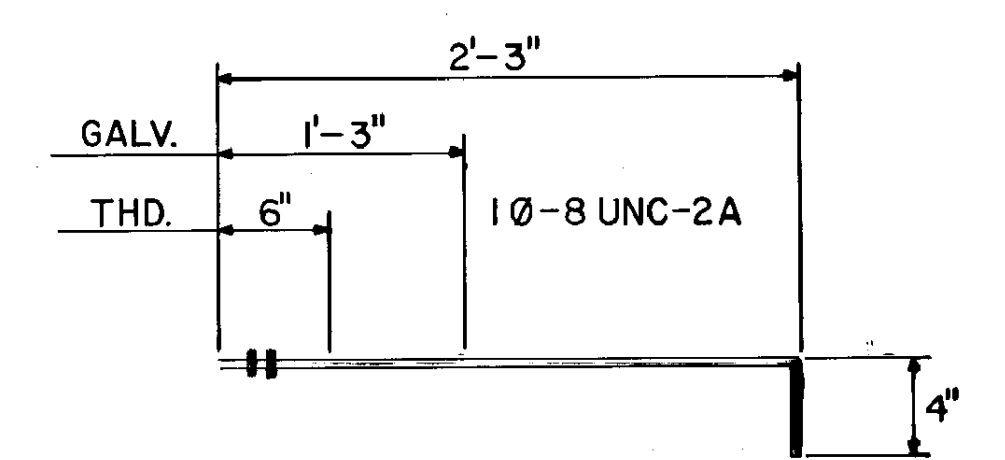

- 1 BAR 1-1/4" DIA. x 3'-10" (A36)
- 2-GALV. HVY. HEX NUTS 1-1/4" (A307)
- 1-GALV. FLATWASHER 1-1/4" (A307)
- 4-ANCHOR BOLTS-AB-CC

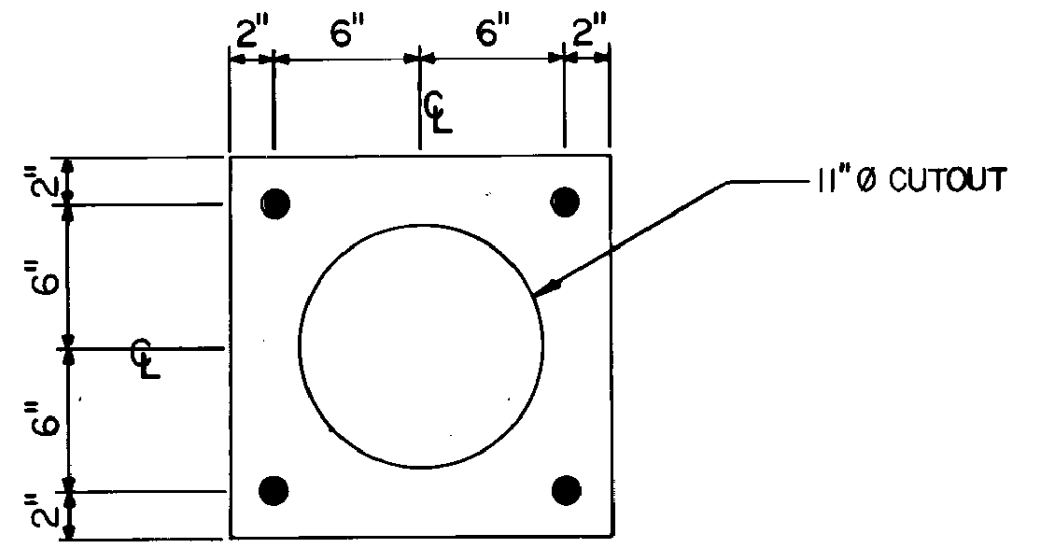

1-PL 3/16"x16"x 1'-4" (A36)

TEMPLATE-TP-CC

CONTROL SYSTEM & AMPACITY UPGRADE				SCALE: NONE				DRAWN BY: JT				ENGR: MG				APPD: -			
0	RFO11-00474	2/2013	RM	JT	RM	BA	CH:	MG	DATE:	04SEP12	DRAWING No.				REV.				
GRDA Grand River Dam Authority P.O. BOX 409 VINITA, OK 74301												S612PS01				0			

GRAND RIVER DAM AUTHORITY  
BEGGS SUBSTATION S612  
BEGGS, OKLAHOMA  
69kV  
69kV COUPLING CAPACITOR &  
POTENTIAL TRANSFORMER STAND