



## OPERATION & CARE MANUAL

**P-2010**

**P-2020**

**P-2030**

**P-2040**

**P-2055**

120V



P-2010



P-2055

## BLANKET WARMING CABINET OPERATION & CARE

# TABLE OF CONTENTS

Environmental Conditions . . . . .	1	Troubleshooting Guide . . . . .	13
Delivery . . . . .	1	Service Parts Lists and Drawings . . . . .	14-22
Unpacking . . . . .	1	Wire Diagrams (REFER TO WIRE DIAGRAM INCLUDED WITH THE UNIT.)	
Safety Procedures and Precautions . . . . .	2	Warranty	
<b>Installation</b>		Transportation Damage and Claims. . . . .	Back Cover
Preparation . . . . .	3	Limited Warranty. . . . .	Back Cover
Electrical Information. . . . .	3		
General Information. . . . .	4		
Dimension Drawings . . . . .	5-8		
<b>Operating Instructions</b>			
Blanket Control Features . . . . .	9		
Blanket Chamber Operational Procedures . . . . .	10		
<b>Care and Cleaning</b>			
Cleaning and Preventative Maintenance . . . . .	11		
Protecting Stainless Steel Surfaces . . . . .	11		
Cleaning Agents . . . . .	11		
Cleaning Materials . . . . .	11		
Care and Cleaning . . . . .	12		
Clean the Unit Regularly. . . . .	12		

## ENVIRONMENTAL CONDITIONS

### Transport and Storage Environmental Conditions (not to exceed 15 days)

- Ambient temperature range of -40° to +70°C (-40° to +159°F).
- Relative humidity range of 10% to 95%, non-condensation.
- Atmospheric pressure range of 50KPa to 106KPa.

### Operational Environmental Conditions

- Unit must acclimate to room temperature in the environment it will be placed. 24 hours is recommended.
- Recommended environmental temperature range is 15°C to 32°C (60°F to 90°F).
- Recommended relative humidity is above 20%, non-condensation.

## UNPACKING AND SET-UP

### DELIVERY

This warming cabinet has been thoroughly tested and inspected to insure only the highest quality unit is provided. Upon receipt, check for any possible shipping damage and report it at once to the delivering carrier. *See Transportation Damage and Claims section located in this manual.*

This appliance, complete with unattached items and accessories, may have been delivered in more than one package. Check to ensure that all standard items and options have been received with each model as ordered.

Save all the information and instructions packed with the appliance. Complete and return the warranty card to the factory as soon as possible to assure prompt service in the event of a warranty parts and labor claim.

This manual must be read and understood by all people using or installing the equipment model. Contact the service department if you have any questions concerning installation, operation, or maintenance.

**NOTE:** All claims for warranty must include the full model number and serial number of the unit.

### UNPACKING

1. Carefully remove the appliance from the carton or crate.

**NOTE:** Do not discard the carton and other packaging material until you have inspected the unit for hidden damage and tested it for proper operation.

2. Read all instructions in this manual carefully before initiating the installation of this appliance.

#### **DO NOT DISCARD THIS MANUAL.**

This manual is considered to be part of the appliance and is to be provided to the owner or manager of the business or to the person responsible for training operators. *Additional manuals are available from the service department.*

3. Remove all protective plastic film, packaging materials, and accessories from the appliance before connecting electrical power.

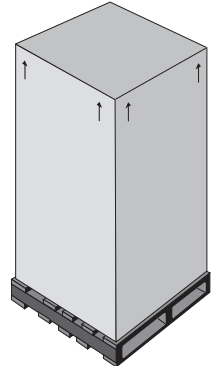

## CAUTION



**TO PREVENT PERSONAL INJURY,  
USE CAUTION WHEN MOVING OR  
LEVELING THIS APPLIANCE.**



## WARNING

**TRANSPORT SHALL ONLY BE DONE  
WITH THE DOORS CLOSED**

## SAFETY PROCEDURES AND PRECAUTIONS

Knowledge of proper procedures is essential to the safe operation of electrically energized equipment. In accordance with generally accepted product safety labeling guidelines for potential hazards, the following signal words and symbols may be used throughout this manual.



### DANGER

Used to indicate the presence of a hazard that **will** cause severe personal injury, death, or substantial property damage if the warning included with this symbol is ignored.



### WARNING

Used to indicate the presence of a hazard that **can** cause personal injury, possible death, or major property damage if the warning included with this symbol is ignored.



### CAUTION

Used to indicate the presence of a hazard that can or will cause minor or moderate personal injury or property damage if the warning included with this symbol is ignored.

### CAUTION

Used to indicate the presence of a hazard that can or will cause minor personal injury, property damage, or a potential unsafe practice if the warning included with this symbol is ignored.



Used to indicate that referral to operating instructions is a mandatory action. If not followed the operator or patient could suffer personal injury.



Used to indicate that referral to operating instructions is recommended to understand operation of equipment.

### NOTE:

Used to notify personnel of installation, operation, or maintenance information that is important but not hazard related.

1. This blanket warming cabinet is intended for warming cotton blankets **ONLY**. No other use for this device is authorized or recommended.
2. This device is intended for use in commercial establishments where all operators are familiar with the purpose, limitations, and associated hazards of this device. Operating instructions and warnings must be read and understood by all operators and users.
3. Any troubleshooting guides, component views, and parts lists included in this manual are for general reference only and are intended for use by qualified technical personnel.
4. This manual should be considered a permanent part of this device. This manual and all supplied instructions, diagrams, schematics, parts lists, notices, and labels must remain with the device if the item is sold or moved to another location.

## NOTE

**A temporary odor may be noticeable upon initial start-up of unit. Contact manufacturer if the odor persists after a day or longer of continuous use.**

## NOTE

**This unit should not be left unattended for periods of more than 24 hours. In case of absences longer than 24 hours, disconnect the warmer from its power source.**

## NOTE

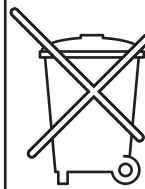

**For equipment delivered for use in any location regulated by the following directive:**

**DO NOT DISPOSE OF ELECTRICAL OR ELECTRONIC EQUIPMENT WITH OTHER MUNICIPAL WASTE.**

## PREPARATION

Before operating the cabinet, clean both the interior and exterior of the unit with a damp cloth and mild soap solution. Wipe with an appropriate disinfectant. Wipe dry with a clean cloth or air dry.

## ELECTRICAL INFORMATION & CAPACITIES



The power specifications are located on the unit identification rating tag. This tag is permanently attached to the unit and must be located to verify power requirements.

### P-2010 POWER REQUIREMENTS

120 V.A.C. — 50/60 Hz, 1 ph  
 0.6 kW, 5.0 Amps  
 Safety Class I Equipment  
 No Applied Parts  
 Mode of Operation: Continuous

 NEMA 5-15P  
 15A - 125V Plug  
 Hospital Grade

 **IP XO**

### P-2040 POWER REQUIREMENTS

120 V.A.C. — 50/60 Hz, 1 ph  
 1.92 kW, 16.0 Amps  
 Safety Class I Equipment  
 No Applied Parts  
 Mode of Operation: Continuous

 NEMA 5-20P  
 20A - 125V Plug  
 Hospital Grade

 **IP XO**

### P-2020 POWER REQUIREMENTS

120 V.A.C. — 50/60 Hz, 1 ph  
 0.7 kW, 5.8 Amps  
 Safety Class I Equipment  
 No Applied Parts  
 Mode of Operation: Continuous

 NEMA 5-15P  
 15A - 125V Plug  
 Hospital Grade

 **IP XO**

### P-2055 POWER REQUIREMENTS

120 V.A.C. — 50/60 Hz, 1 ph  
 1.8 kW, 15 Amps  
 Safety Class I Equipment  
 No Applied Parts  
 Mode of Operation: Continuous

 NEMA 5-20P  
 20A - 125V Plug  
 Hospital Grade

 **IP XO**

### P-2030 POWER REQUIREMENTS

120 V.A.C. — 50/60 Hz, 1 ph  
 1.0 kW, 8.3 Amps  
 Safety Class I Equipment  
 No Applied Parts  
 Mode of Operation: Continuous

 NEMA 5-15P  
 15A - 125V Plug  
 Hospital Grade

 **IP XO**

Wire diagram is located under top cover of unit.

Grounding reliability can only be achieved when equipment is connected to an equivalent receptacle marked "Hospital Grade."



Protective Earth  
 Ground Symbol

Medical Equipment classified by Underwriters Laboratories with Respect to Electrical Shock, Fire and Mechanical Hazards only, in Accordance with UL 60601-1 and CAN/CSA C22.2 No. 601.1.



UL File No.  
 E201645

# DANGER



**AT NO TIME SHOULD THE INTERIOR OR EXTERIOR BE STEAM CLEANED, HOSED DOWN, OR FLOODED WITH WATER OR LIQUID SOLUTION OF ANY KIND. DO NOT USE WATER JET TO CLEAN.**



**SEVERE DAMAGE OR ELECTRICAL HAZARD COULD RESULT. WARRANTY BECOMES VOID IF APPLIANCE IS FLOODED**



Hazardous  
 Voltage Present



# DANGER



**ENSURE POWER SOURCE MATCHES VOLTAGE IDENTIFIED ON APPLIANCE RATING TAG.**

## GENERAL INFORMATION

This warming cabinet is designed to elevate blanket temperatures to a level which will increase patient comfort.

The warming cabinet is constructed with stainless steel exterior casing and door with handle and hinges designed to withstand heavy usage. A door with window allows observation of inventory with the door closed. The cabinet is warmed using low-heat-density electrothermal cable array. The electrothermal cable is positioned in the floor and two sides of the warming cabinet, providing even heating of the interior chamber.

The temperature of each chamber is regulated by an electronic control consisting of a 4 digit L.E.D. display, ON/OFF button, INCREASE and DECREASE buttons, integrated control lock-out feature, timer and a series of prompt sequence indicators. The design and operational characteristics of the cabinet eliminate the need for a heat circulating fan.

The electronic control can easily be set to operate in Fahrenheit or Celsius. After a power failure, the cabinet will remember its programming and begin to operate as before. The ON/OFF indicator will blink to indicate a failure occurred; pressing the ON/OFF button once will eliminate this blinking. A thermal shut-off system, separate from the electronic control, is included as an additional safety feature.

The control will display temperature in whole degrees.

The design and operational characteristics of the chamber eliminate the need for a heat circulating fan.

The electronic control has an adjustable temperature range of 37° to 93°C (98° to 200°F).

The TIMER feature allows the user to program the control to automatically turn on and turn off once during a 24 hour period at selected times. This enables the chamber to be shut off automatically at night to save energy, but to turn on again in the early morning to ensure warm blankets are available.

### P-2010 INFORMATION:

The cabinet is equipped with one (1) epoxy-coated blanket support assembly and is furnished with four (4) 1-1/4" (31mm) non-skid rubber feet.

### P-2020 INFORMATION:

The cabinet is equipped with one (1) epoxy-coated blanket support assembly and one (1) center shelf. The cabinet is furnished with one (1) set of 5" (127mm) heavy duty casters, two with locking brake.

### P-2030 INFORMATION:

The cabinet is equipped with one (1) epoxy-coated blanket support assembly and one (1) center shelf. The cabinet is furnished with one (1) set of 5" (127mm) heavy duty casters, two with locking brake.

### P-2040 INFORMATION:

Each compartment is equipped with one (1) epoxy-coated blanket support assembly and one (1) center shelf. The cabinet is furnished with one (1) set of 5" (127mm) heavy duty casters, two with locking brake.

### P-2055 INFORMATION:

The cabinet is equipped with one (1) epoxy-coated blanket support assembly and one (1) center shelf per door opening. The cabinet is furnished with one (1) set of 5" (127mm) heavy duty casters, two with locking brake.

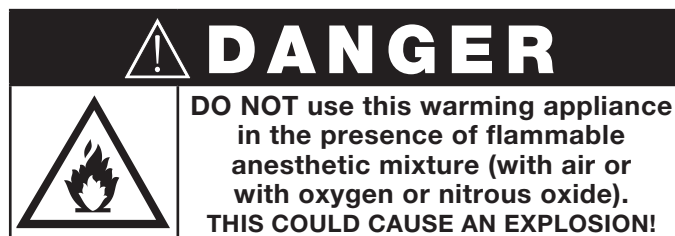
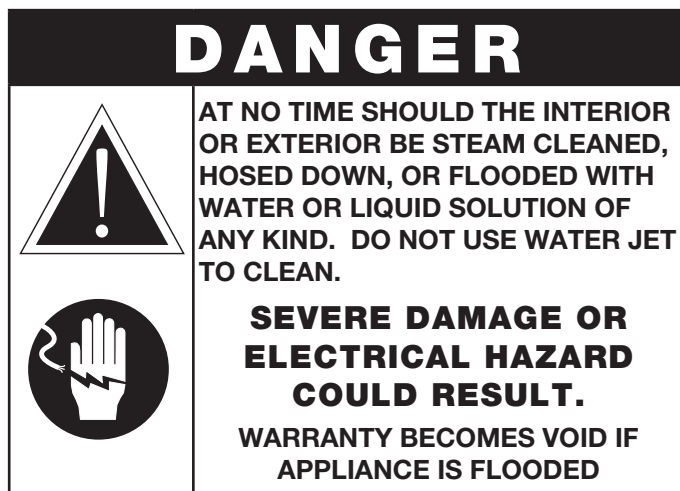

## P - 2010 DIMENSIONS

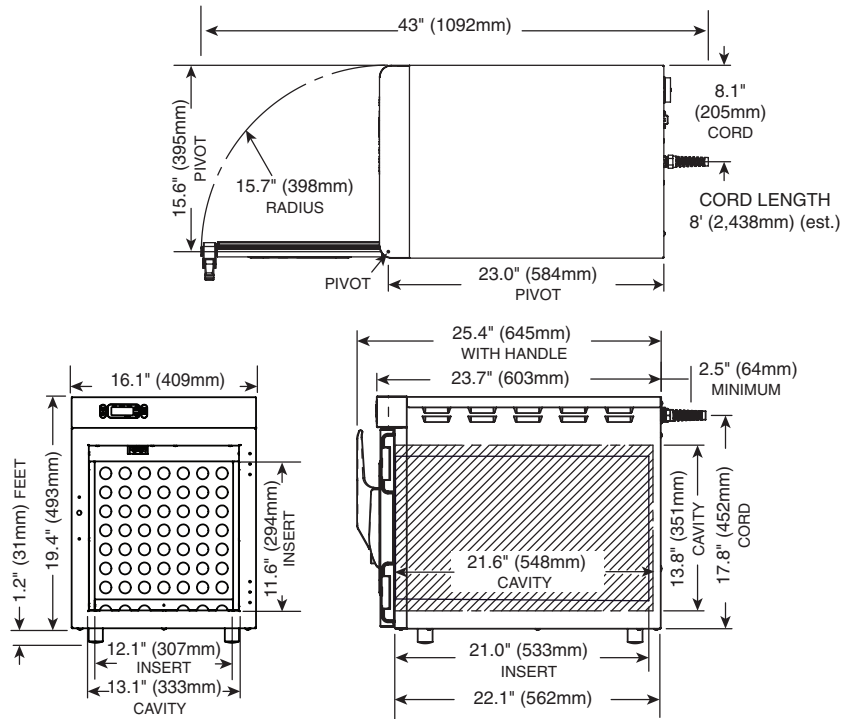

## P - 2020 DIMENSIONS

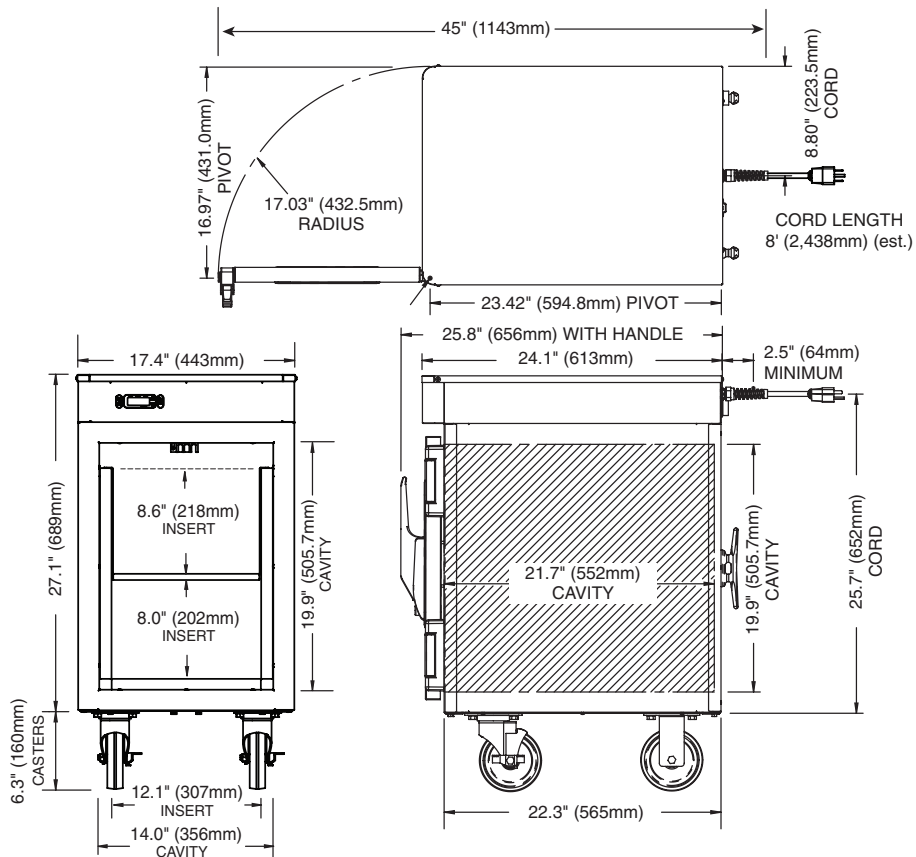

# P - 2030 DIMENSIONS

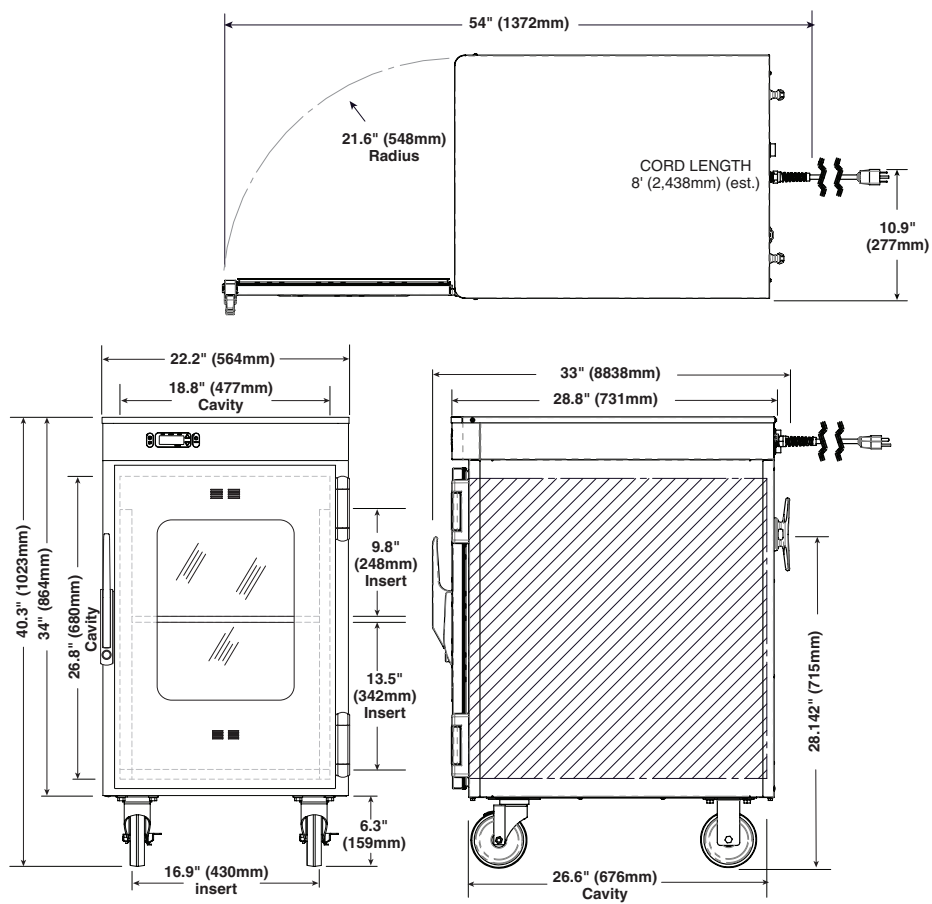



# P - 2040 DIMENSIONS

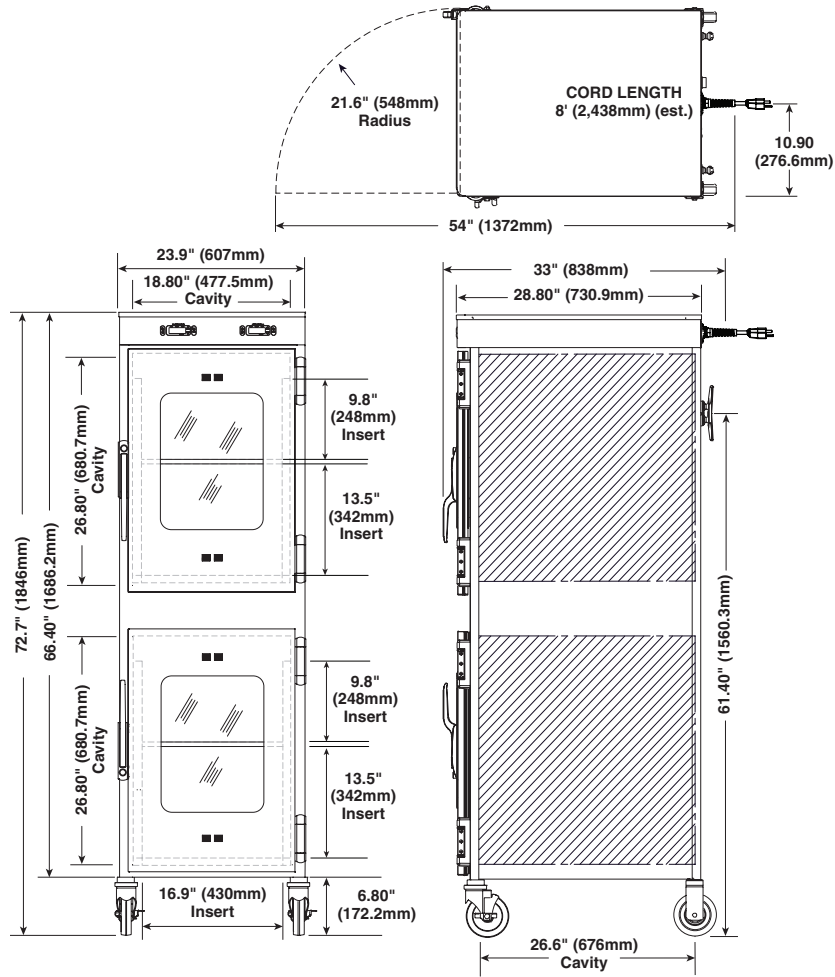

# P - 2055 DIMENSIONS

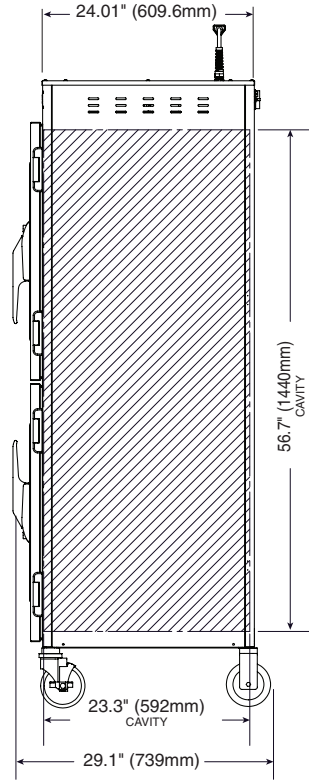
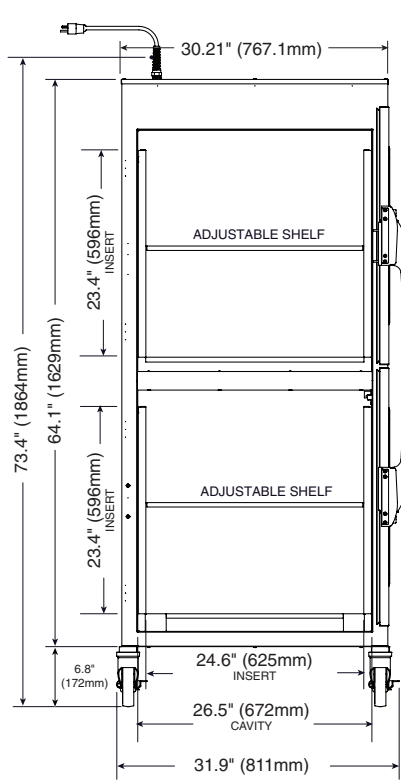
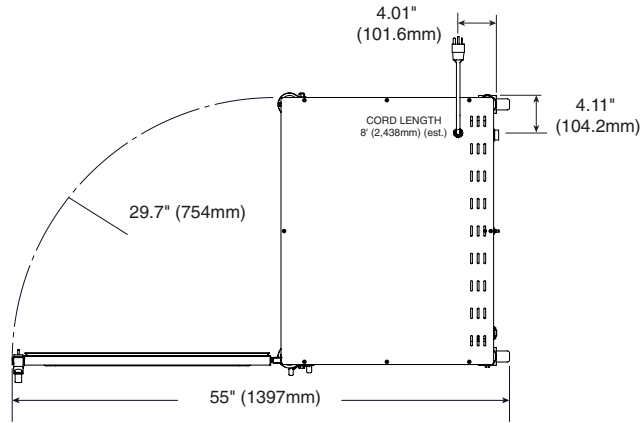

# BLANKET CONTROL FEATURES

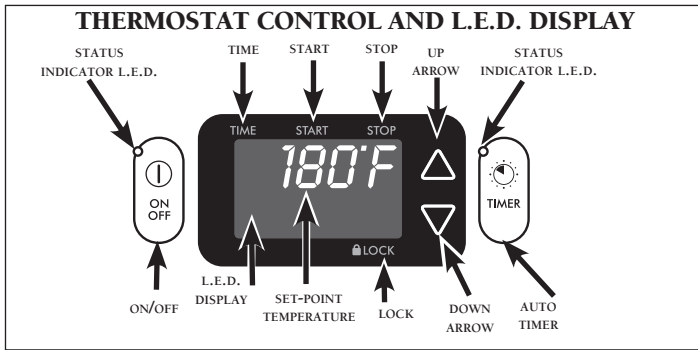

The following refers to features that are available when the control is powered on.

## CONTROL PANEL BUTTONS

### ON/OFF BUTTON

Press the ON/OFF button to power on the control. Press and hold the ON/OFF button for 2 seconds to power the control off. The status indicator L.E.D will illuminate according to the power state.

### UP ARROW / DOWN ARROW BUTTONS

Used to increase or decrease the temperature set-point. Additionally used to set the current time, auto-start, and auto-stop times. Continual pressure to a button will increase the increments in which the values will change.

### TIMER BUTTON

Blanket warmers have a timer button which is used to program the time of day, as well as the automated start and stop times. See “Setting the Time” instructions on this page.

### L.E.D. DIGITAL DISPLAY

The control has a four-digit L.E.D. display. When the control is activated, the display will show current temperature set-point. When programming the timer, the display will show hour and minutes.

## L.E.D. DISPLAY STATUS INDICATORS

### TIME

Illuminates while current time of day is displayed when programming the TIMER mode.

### START

Illuminates while the start time is displayed when programming the TIMER Auto-On mode.

### STOP

Illuminates while the stop time is displayed when programming the TIMER Auto-Off mode.

### LOCK

Illuminates when the lock feature is engaged.

## POWER FAIL DETECTION

If the power were to fail for any reason while control is powered on, the warmer will retain in memory its current operating state. When the power is restored, the control will alarm once and resume operating in its previously set mode, but will alert the operator that such an event has occurred: The ON/OFF status indicator will flash.

Press the ON/OFF button once to acknowledge that the power has been restored. The ON/OFF status indicator will stop flashing. When pushing the ON/OFF button, the display will indicate the time period of the outage in hours and minutes (HH:MM), then return to the normal display and previously set mode. Inspection of the product in the cavity may be necessary.

## TEMPERATURE FORMAT SELECTION

While the controller is in the off mode, press and hold the UP ARROW button for 5 seconds. Press again to switch between Fahrenheit (°F) or Celsius (°C).

## CAVITY TEMPERATURE DISPLAY

To reference the cavity air temperature, push and hold the TIMER and UP ARROW buttons. While holding both buttons, the value in the display refers to the temperature at the cavity sensor.

## OPERATIONAL SOUND SELECTION

While the controller is in the off mode, press and hold the DOWN ARROW button for 5 seconds. Press again to turn the sound ON (I) and OFF (O).

## CONTROL LOCK

The warmer control can be locked so that no changes can be made to the temperature set-point or the mode selection. Press the ON/OFF button and the UP arrow button at the same time. The LOCK indicator will illuminate. Attempts to operate the ON/OFF button, or to change the temperature set-point will be unsuccessful. To unlock the control, press the ON/OFF button and the DOWN arrow button at the same time. The control will unlock and the LOCK indicator will extinguish.

## SETTING THE TIME

**NOTE:** If you do not wish to use the automated timer feature, then you do not need to set the time and this section can be skipped.

Press the TIMER button to illuminate the TIME indicator. The current time of day will show on the display in 24-hour format (HH:MM). Use the UP or DOWN arrow to set the display to the current time. Press the TIMER button again to transition to the START Auto-On Time. This is the time that the control will automatically turn on when enabled. Adjust to desired start time using the UP or DOWN arrow buttons. Press the TIMER button again to transition to the STOP Auto-Off Time. This is the time the control will automatically turn off when enabled. Adjust to desired stop time. Press the TIMER button again to enable the Auto-Timer feature. The TIME status indicator L.E.D. will illuminate when the Auto-Time function is activated. To disable, press and hold the TIMER button until the indicator L.E.D. goes off.

**NOTE:** When the Auto-On and the Auto-Off times are equal, the unit will recognize the Auto-Off time ONLY and the control will never turn on without user intervention.

## BLANKET CHAMBER OPERATIONAL PROCEDURES

1. The appliance should be plugged into an appropriate hospital grade receptacle as specified on the electrical information page.

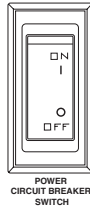

2. Turn on the power circuit breaker switch, which is located at the back of the appliance. It is a rocker-type switch with international ON (I) and OFF (O) markings.

3. **ACTIVATE CONTROL BY PRESSING THE ON/OFF BUTTON ON CONTROL PANEL ONCE.**

The ON/OFF indicator will illuminate and remain lit until the unit is turned off. The digital L.E.D. display will indicate last temperature set-point of compartment.

4. **SET DESIRED TEMPERATURE.**

To set the blanket warming temperature, press and hold the UP or DOWN ARROW buttons to change the value shown in the display. The temperature set-point range is 37 - 93°C (98 - 200°F).

5. **LOAD THE CHAMBER WITH 100% COTTON BLANKETS. DO NOT WARM SYNTHETIC BLEND FABRICS OR ITEMS CONTAINING PLASTIC, RUBBER OR METAL SNAPS, STUDS, HOOKS, ETC.**

Check that the epoxy-coated blanket support assembly and shelf is in place. This blanket support assembly and shelf **MUST** be used to hold blankets. A full load of blankets will take 2-3 hours to reach optimum temperature. Make certain the cabinet door is securely closed after initial loading and following each blanket removal.

**Note: Do not block sensor by overloading cabinet with blankets.**

6. **ROTATE LOAD OF BLANKETS DAILY.**

Rotate the blankets at the bottom of the load to the top to ensure equal usage. Failure to rotate blankets can cause blankets to discolor.

**Note: Avoid using flammable cabinet cleaning agents, as well as blanket cleaning agents that cause fabric to become brittle over time.**

### CAUTION

**BLANKET SUPPORT ASSEMBLY AND SHELF MUST BE USED WHEN WARMING BLANKETS.**

### CAUTION

**DO NOT OVERLOAD CABINET. BLANKETS MUST NOT EXCEED HEIGHT OF SUPPORT ASSEMBLY. ALLOW 1" GAP BETWEEN LOWER BLANKETS AND SHELF.**



*Load blankets only to the top of the blanket support assembly.*

# CLEANING AND PREVENTIVE MAINTENANCE

## PROTECTING STAINLESS STEEL, EPOXY COATED AND PLASTIC SURFACES



It is important to guard against corrosion in the care of stainless steel surfaces. Harsh, corrosive, or inappropriate chemicals can completely destroy the protective surface layer of stainless steel, epoxy or plastic. Abrasive pads, steel wool, or metal implements will abrade surfaces causing damage to this protective coating and will eventually result in areas of corrosion. Even water, particularly hard water that contains high to moderate concentrations of chloride, will cause oxidation and pitting that result in rust and corrosion. In addition, many acidic spills left to remain on metal surfaces are contributing factors that will corrode surfaces.

Proper cleaning agents, materials, and methods are vital to maintaining the appearance and life of this appliance. Spilled items should be removed and the area wiped as soon as possible but at the very least, a minimum of once a day. Always thoroughly rinse surfaces after using a cleaning agent and wipe standing water as quickly as possible after rinsing.

## PREVENTATIVE MAINTENANCE

1. Ensure that the correct Operation and Care Manual is available to all users.
2. Ensure that all users have been properly trained in unit's operation.
3. Do not overload cabinet.
  - **Blanket Warmer:** 1" (25mm) from top interior of unit
  - **Fluid Warmer:** See electrical/capacity page
4. Inspect condition of plug and cord. Replace if damaged.
5. Clean dust from outer vents surrounding the unit and around top of bonnet (if applicable).
6. Check door gasket integrity. Are there any tears? Is the gasket worn or loose? Make sure seal is tight to unit body. Replace gasket if integrity is compromised.
7. Check air temperature sensor mount on the interior of chamber. Is the guard in place? Are the wires in good condition?
8. Check insert assembly (depends on unit):
  - **Blanket Warmer:** Check the blanket support assembly and shelf. Is the assembly in place? Are any pieces missing?
  - **Fluid Warmer:** Check basket and side rail condition. Do baskets move smoothly and freely?
9. Check condition of casters or feet. Ensure components are secure and tightly threaded.
10. Check control panel overlay condition. Are there any tears or excessive wear on the graphic? Does the control work properly when buttons are pushed?
11. Check that all control and interior LEDs light up.
12. Is the set temperature comparable to the actual temperature displayed? Check cavity air temperature with a quality thermocouple placed 1" (25mm) from the cavity sensor not allowing it to touch any surface. Monitor for approximately one hour in an empty cavity.



## CLEANING AGENTS

Use non-abrasive cleaning products designed for use on stainless steel surfaces. Cleaning agents must be chloride-free compounds and must not contain quaternary salts. Never use hydrochloric acid (muriatic acid) on stainless steel surfaces. Always use the proper cleaning agent at the manufacturer's recommended strength. Contact your local cleaning supplier for product recommendations.

## CLEANING MATERIALS

The cleaning function can usually be accomplished with the proper cleaning agent and a soft, clean cloth. When more aggressive methods must be employed, use a non-abrasive scouring pad on difficult areas and make certain to scrub with the visible grain of surface metal to avoid surface scratches. Never use wire brushes, metal scouring pads, or scrapers to remove residue.



<b>CAUTION</b>	
	<b>TO PROTECT SURFACES, COMPLETELY AVOID THE USE OF ABRASIVE CLEANING COMPOUNDS, CHLORIDE BASED CLEANERS, OR CLEANERS CONTAINING QUATERNARY SALTS. NEVER USE HYDROCHLORIC ACID (MURIATIC ACID) ON STAINLESS STEEL. NEVER USE WIRE BRUSHES, METAL SCOURING PADS OR SCRAPERS.</b>
	
	

**Contact service for immediate repair if any of the above problems exist.**

## CARE AND CLEANING

The cleanliness and appearance of this equipment will contribute considerably to its operating efficiency. Make certain the cabinet and door gasket are kept free of any debris that may accumulate. Good equipment that is kept clean works better and lasts longer.



### CLEAN THE UNIT REGULARLY:

1. Disconnect the cabinet from the power source.
2. Remove all detachable items such as blanket support assembly and shelf. Clean these items separately.

**NOTE:** Avoid the use of abrasive cleaning compounds, chloride based cleaners, or cleaners containing quaternary salts. Never use hydrochloric acid (muriatic acid) on stainless steel.



3. Clean the interior metal surfaces of the cabinet with a damp cloth and any mild commercial detergent. Avoid the use of abrasive cleaning compounds. Rinse surfaces by wiping with sponge & clean warm water. Remove excess water with sponge and wipe dry with a clean cloth or air dry. Leave doors open until interior is completely dry.
4. Interior can be wiped with a sanitizing solution after cleaning and rinsing. This solution must be approved for use on stainless steel surfaces. Replace blanket support assembly.
5. Clean the exterior of the cabinet with a cleaner recommended for stainless steel surfaces. Spray the cleaner on a clean cloth and wipe with the grain of the stainless steel.
6. Clean the window glass, if applicable, with a standard commercial glass cleaner.
7. Wipe control panel, door vents, door handles, and door gaskets thoroughly since these areas harbor debris.
8. Wipe door gaskets and control panel dry with a clean, soft cloth.
9. To help maintain the protective film coating on polished stainless steel, clean the exterior of the cabinet with a cleaner recommended for stainless steel surfaces. Spray the cleaning agent on a clean cloth and wipe with the grain of the stainless steel.

Always follow appropriate state or local health (hygiene) regulations regarding all applicable cleaning and sanitation requirements.

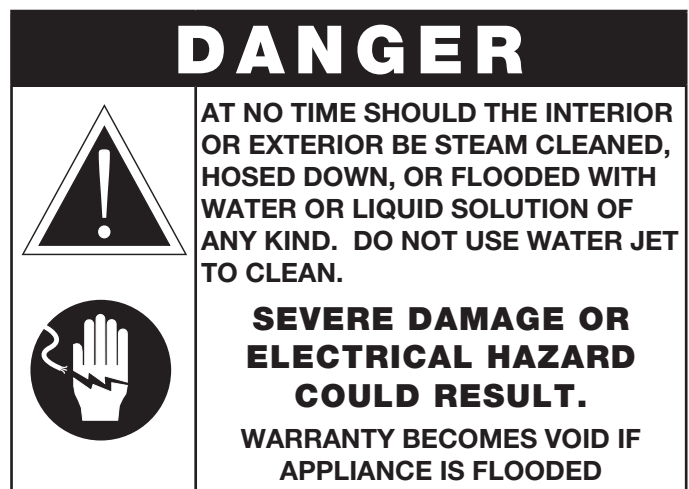
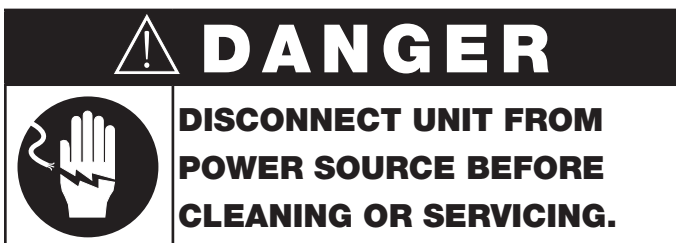

(IP X0 - Listed as Ordinary)

**NOTE:** If your unit is not operating properly, check the following before calling your authorized service agent. Check the power applied to the unit. Is the plug in outlet? Is the power circuit breaker switch in rear of unit OK? Has the high limit manual reset tripped? If so, reset. (See “Manual Reset Instructions” below.)

If temperature calibration adjustment is required, call service for proper instruction.

Do not attempt to repair or service beyond this point. Contact manufacturer for nearest authorized service agent. Repairs made by any other service agent without prior authorization by manufacturer will void the warranty on the unit.

This chart is provided for the assistance of qualified technicians only and is not intended for use by untrained or unauthorized service personnel.

<b>TROUBLESHOOTING GUIDE</b>		
<b>CODE</b>	<b>DESCRIPTION</b>	<b>ACTION REQUIRED</b>
<b>door</b>	<b>Door left open for more than 3 minutes</b>	<ul style="list-style-type: none"> <li>• Close door</li> <li>• Verify door switch operation. Replace if necessary.</li> </ul>
<b>E-10</b>	<b>Cavity Air Sensor Shorted</b>	<ul style="list-style-type: none"> <li>• Detach the sensor from the terminal block. Use an Ohm meter to measure the resistance of the sensor. Check sensor at 32°F (0°C) using a container of ice water. Ohm reading should be 100. If Ohm reading is +/- 10, replace sensor.</li> <li>• Check wires for integrity. Check for proper and secure connections at the control and terminal block. If necessary, re-secure the faulty connections.</li> <li>• If error continues call Service.</li> </ul>
<b>E-11</b>	<b>Cavity Air Sensor Open</b>	<ul style="list-style-type: none"> <li>• Detach the sensor from the terminal block. Use an Ohm meter to measure the resistance of the sensor. Check sensor at 32°F (0°C) using a container of ice water. Ohm reading should be 100. If Ohm reading is +/- 10, replace sensor.</li> <li>• Check wires for integrity. Check for proper and secure connections at the control and terminal block. If necessary, re-secure the faulty connections.</li> <li>• If error continues call Service.</li> </ul>
<b>E-30</b>	<b>Under Temperature (Blanket warmers only)</b>	<ul style="list-style-type: none"> <li>• Blanket chamber temperature has been lower than the set temperature for 90 minutes or longer.</li> <li>• Check that door is closed.</li> <li>• Not preheated due to an overpacked cavity.</li> </ul>
<b>E-31</b>	<b>Over Temperature</b>	<ul style="list-style-type: none"> <li>• Unit may be overloaded. Redistribute inventory. <b>Do not exceed height of insert.</b></li> <li>• Check sensor at 32°F (0°C) using a container of ice water. Ohm reading should be 100. If Ohm reading is +/- 10, replace sensor.</li> <li>• Check wires for integrity. Check for proper and secure connections at the control and terminal block. If necessary, re-secure the faulty connections.</li> <li>• Relay may be defective.</li> <li>• If error continues call Service.</li> </ul>
<b>E-50</b>	<b>Temp. Measurement Error</b>	<ul style="list-style-type: none"> <li>• Call Service.</li> </ul>
<b>E-60</b>	<b>Real-Time Clock Error</b>	<ul style="list-style-type: none"> <li>• Unit may have been unplugged for an extended period of time.</li> <li>• To resolve, turn circuit breaker switch to ON position for 1 minute, then turn circuit breaker switch to the OFF position for 5 seconds, and then back to ON. The error message should no longer appear in the display.</li> <li>• In order for the unit to fully recharge, it should remain plugged in and power circuit breaker switch turned ON for at least 24 hours after resetting.</li> <li>• Upon resolving an E-60 error, check that the date and time are correct.</li> </ul>
<b>E-61</b>	<b>Real-Time Clock Error</b>	<ul style="list-style-type: none"> <li>• Call Service.</li> </ul>
<b>E-80</b>	<b>EEPROM Error</b>	<ul style="list-style-type: none"> <li>• Ensure that all temperature and times are properly set.</li> <li>• If error continues call Service.</li> </ul>
<b>E-81</b>	<b>EEPROM Error</b>	<ul style="list-style-type: none"> <li>• Call Service.</li> </ul>
<b>E-82</b>	<b>EEPROM Error</b>	<ul style="list-style-type: none"> <li>• Call Service.</li> </ul>
<b>E-83</b>	<b>EEPROM Error</b>	<ul style="list-style-type: none"> <li>• Call Service.</li> </ul>
<b>E-87</b>	<b>EEPROM Error</b>	<ul style="list-style-type: none"> <li>• Stored offsets corrupted. Offsets reset to 0. Control may need a recalibration. Possible bad EEPROM.</li> <li>• If error continues call Service.</li> </ul>
<b>E-90</b>	<b>Button Stuck</b>	<ul style="list-style-type: none"> <li>• A button has been held down for &gt;60 seconds. Adjust control. Error will reset when the problem has been resolved.</li> </ul>
<b>E-99</b>	<b>Hardware Over Temp</b>	<ul style="list-style-type: none"> <li>• Inspect connections and condition of high limit bimetal thermostat and the fan switch (fluid warmers only). Adjust if necessary.</li> <li>• Check operation of cavity fan motor (fluid warmers only). Air movement from the cavity fan blade should move the safety sail switch to the closed position. Adjustment to the fan blade may be needed or replacement of the fan motor.</li> <li>• If error continues call Service.</li> </ul>

**NOTE:** All error codes must be cleared using the circuit breaker switch or power switch on the rear of the unit.

**Manual Reset Instructions:** Locate the manual reset button on back of unit. (Location may vary slightly from diagram.) Using a pen, screwdriver or other long, thin implement, firmly push reset button. You will hear an audible click when the button is reset. If reset button trips again while unit is running, contact a qualified service technician.

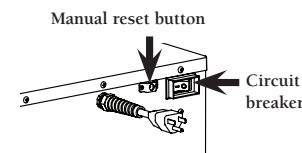

# SERVICE PARTS LIST (SEE SERVICE VIEWS ON FOLLOWING PAGES)

LOC	DESCRIPTION	QTY	P-2010	QTY	P-2020	QTY	P-2030	QTY	P-2040	QTY	P-2055
1.	WINDOW DOOR ASSEMBLY	1	5009043	1	5010808	1	5001253	2	5001253†	2	5010984†
2.	DOOR HANDLE	1	HD-24171	1	HD-24171	1	HD-24171	2	HD-24171†	2	HD-24171†
3.	SCREW, M5 x 0.8MM FLAT PHILLIPS	4	SC-35259	4	SC-35259	4	SC-35259	4	SC-35259†	4	SC-35259†
4.	CONTROL PANEL OVERLAY	1	PE-28980	1	PE-28982	1	PE-28984	2	PE-29026	1	PE-29045
	CONTROL PANEL OVERLAY*, PASS THROUGH	—	—	—	—	—	—	—	—	1	PE-29046
5.	TOP COVER	1	5000730	1	5001014	1	5008861	1	5003367	1	1015280
6.	STRAIN RELIEF BUSHING	1	BU-34836*	1	BU-34836	1	BU-34836*	1	BU-34836*	1	BU-34836
7.	CORDSET, HOSPITAL GRADE, 10FT (3m)	1	E3025CD	1	E3025CD	1	E3025CD	1	E3029CD	1	E3029CD
8.	CASING	1	1009697	—	—	—	—	—	—	—	—
9.	REAR COVER	—	—	1	1010748	1	1010768	1	1010731	1	1010901
10.	SIDES	—	—	2	1010721	2	1010744	2	1010698	2	1015281
11.	BUMPER FEET	4	BM-22606	—	—	—	—	—	—	—	—
12.	CASTERS, 5" (127mm), PLATE, RIGID	—	—	2	CS-2025	2	CS-2025	—	—	—	—
13.	CASTERS, 5" (127mm), PLATE, SWIVEL W/ BRAKE	—	—	2	CS-2026	2	CS-2026	—	—	—	—
14.	CASTERS, 5" (127mm), STEM, RIGID	—	—	—	—	—	—	2	CS-24874	2	CS-24874
15.	CASTERS, 5" (127mm), STEM, SWIVEL W/ BRAKE	—	—	—	—	—	—	2	CS-24875	2	CS-24875
16.	SCREWS, HINGE, M5 x 0.8 x 20MM FLAT PHILLIPS	6	SC-23868	6	SC-23868	6	SC-23868	12	SC-23868	12	SC-23868
	SCREWS, HINGE, 10-32 x 3/4" FLAT PHILLIPS	6	SC-2072*	6	SC-2072*	6	SC-2072*	12	SC-2072*	12	SC-2072*
17.	HINGE SET (1 SET OF 2 HINGES)	1	HG-2015	1	HG-22338	1	HG-22338†	2	HG-22338†	2	HG-2015†
18.	BLANKET INSERT ASSEMBLY	1	5012085	1	5012915	1	5012175	2	5012175	1	5012196
19.	SHELF	—	—	1	5012917	1	5012177	2	5012177	2	5012133
20.	BLANKET SUPPORT, SIDE	1	5012086	—	—	1	5012173	2	5012173	1	5012193 (UPPER)
21.	BLANKET SUPPORT, BOTTOM	1	5012089	1	5012919	—	—	—	—	1	5012191 (LOWER)
22.	RIVETS	7	RI-2100*	—	—	—	—	—	—	—	—
23.	SENSOR	1	SN-33541	1	SN-33541	1	SN-33541*	2	SN-33541*	1	SN-33541
24.	THERMOSTAT, MANUAL RESET	1	TT-33476	1	TT-33476	1	TT-33476	1	TT-33476	1	TT-34600
25.	SCREWS, 8-32 x 1" FLAT PHILLIPS	1	SC-22138	1	SC-22138	1	SC-22138	2	SC-22138	1	SC-22138
26.	SENSOR BLOCK	1	BK-28344	1	BK-28344	1	BK-28344	2	BK-28344*	1	BK-27983
27.	SCREWS, 8-32 x 1/4" PAN PHILLIPS	**	SC-2459	**	SC-2459	**	SC-2459	**	SC-2459	**	SC-2459
28.	SCREWS, 6-32 x 1/2" FLAT PHILLIPS	—	—	—	—	—	—	—	—	2	SC-2239
29.	SENSOR GUARD	1	1010539	1	1010539	1	1010539	1	1010539	—	—
30.	BOTTOM ASSEMBLY	1	E4042*	1	5010822	1	5010672	1	5011294*	1	1010911
31.	FULL PERIMETER RUBBER BUMPER (OPTIONAL)	—	—	1	5010798*	-	5015440*	1	5015440	—	—
32.	BLOCK, MANUAL RESET PROBE	—	—	—	—	—	—	—	—	1	BK-34822
33.	DOOR GASKET	1	E2132GS	1	GS-22950*	1	GS-23794*	2	GS-23794*	2	GS-26634*

\* NOT SHOWN    \*\*QUANTITY VARIES    † QUANTITY DOUBLES FOR PASS-THROUGH UNIT

PART NUMBERS AND DRAWINGS ARE SUBJECT TO CHANGE WITHOUT NOTICE.



SERVICE

P-2010 FULL ASSEMBLY & INTERIOR

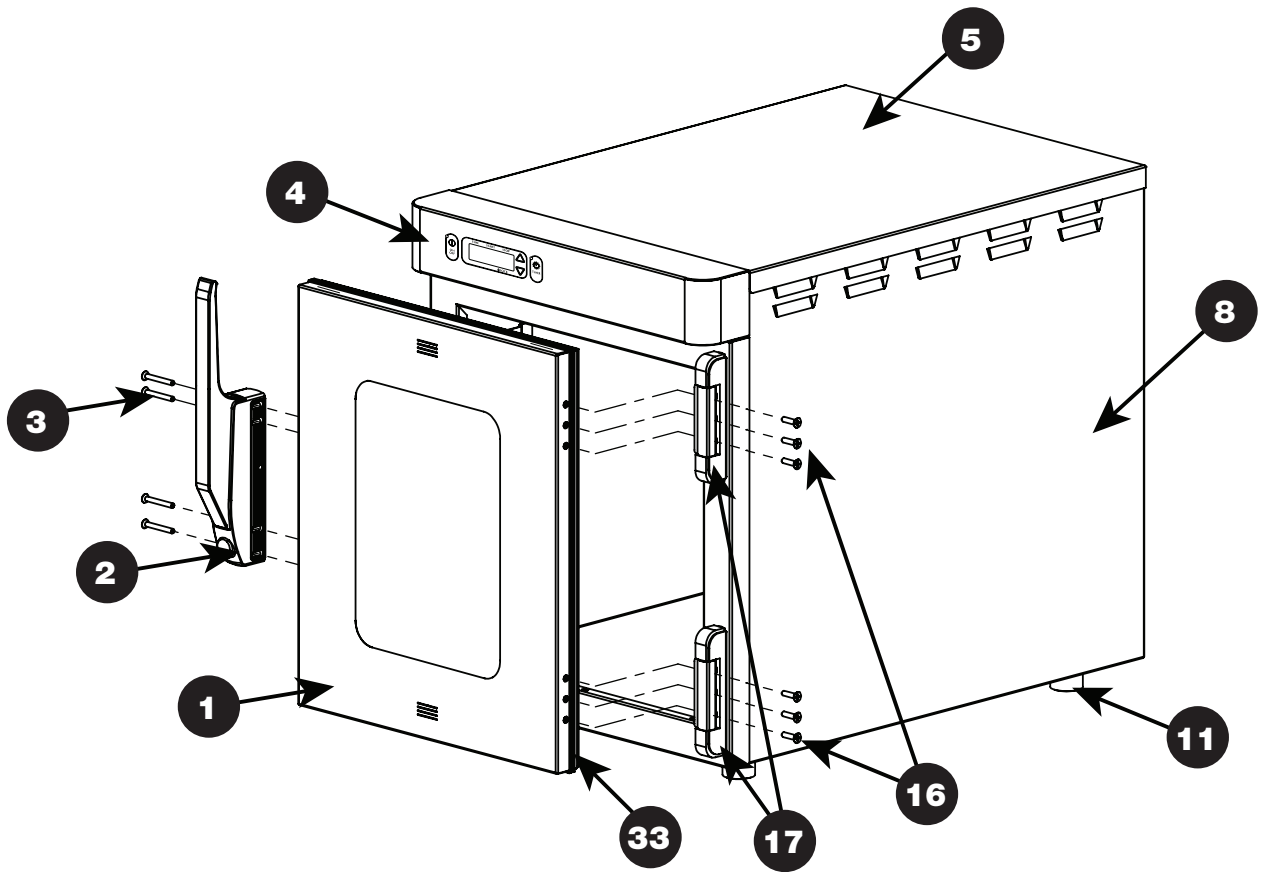

18 BLANKET INSERT ASSEMBLY

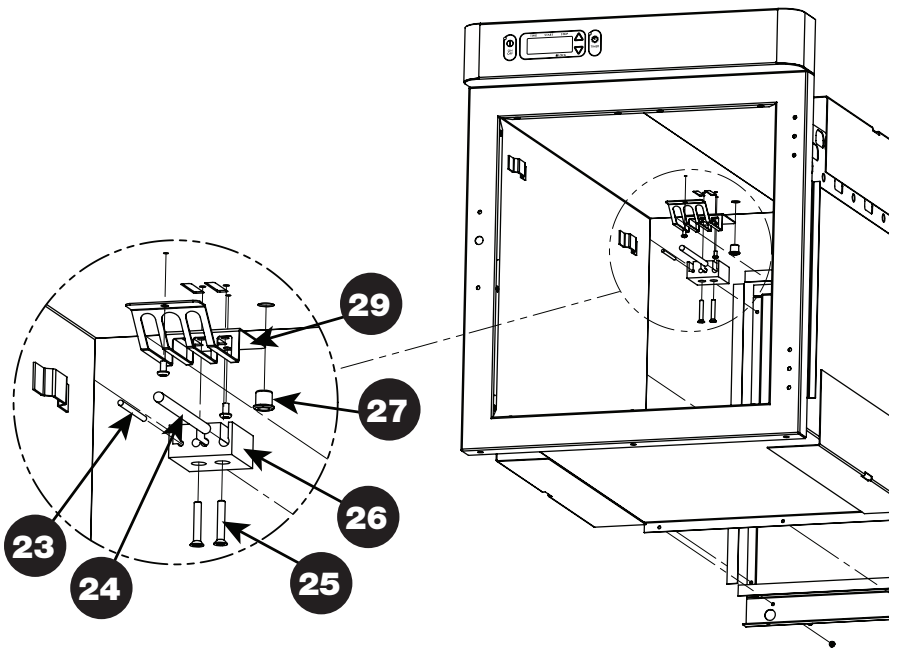
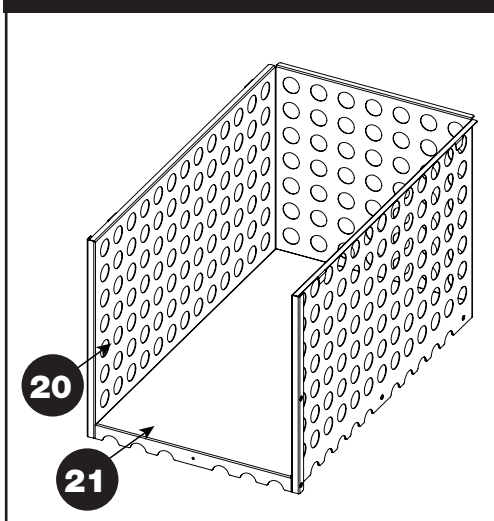

PART NUMBERS AND DRAWINGS ARE SUBJECT TO CHANGE WITHOUT NOTICE.

SERVICE

P-2020 FULL ASSEMBLY & INTERIOR

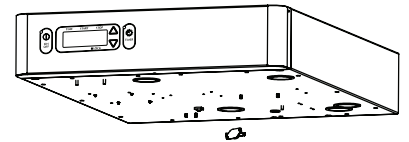
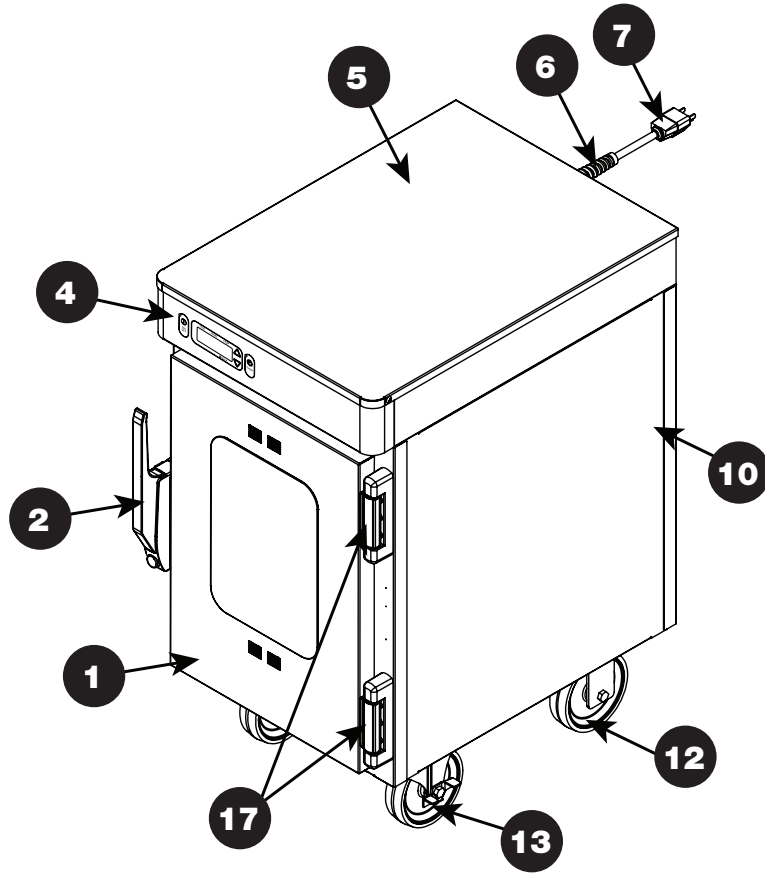

18 BLANKET INSERT ASSEMBLY

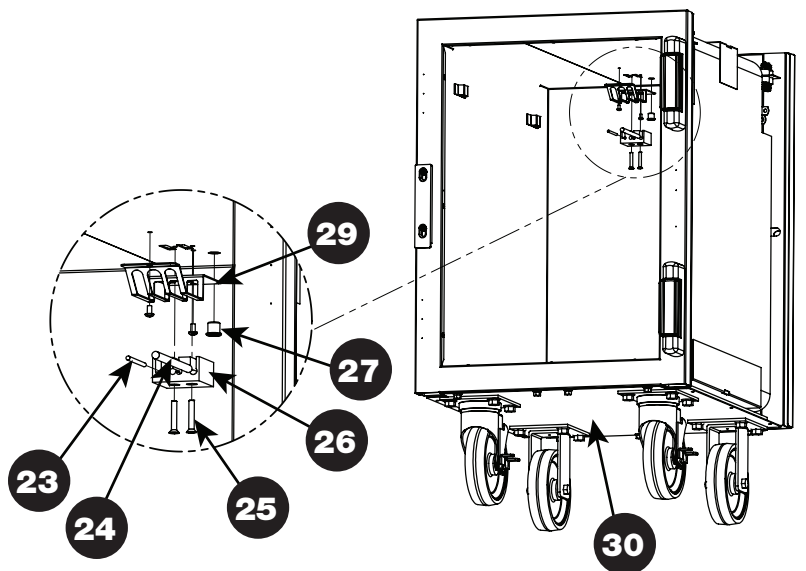
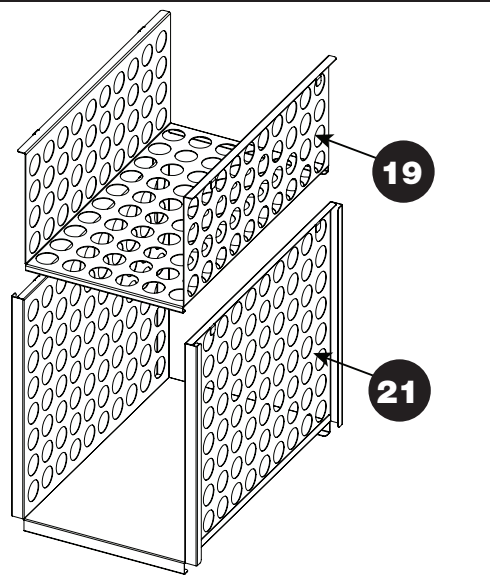

PART NUMBERS AND DRAWINGS ARE SUBJECT TO CHANGE WITHOUT NOTICE.

SERVICE

P-2030 FULL ASSEMBLY & INTERIOR

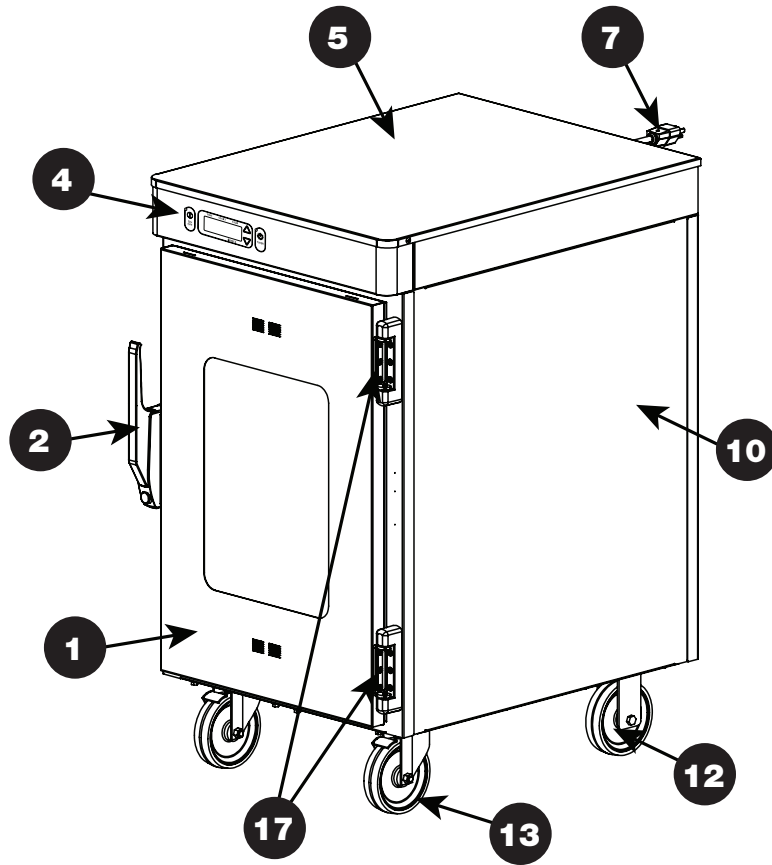

18 BLANKET INSERT ASSEMBLY

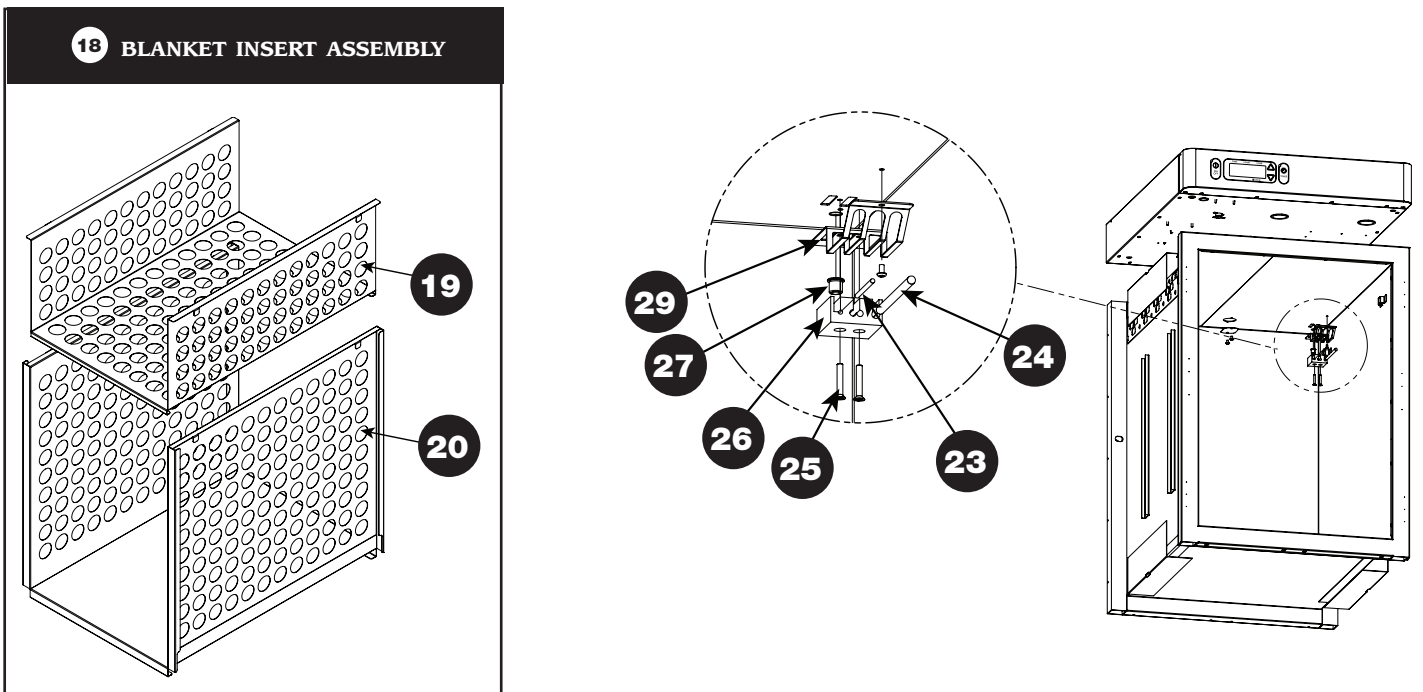

PART NUMBERS AND DRAWINGS ARE SUBJECT TO CHANGE WITHOUT NOTICE.

SERVICE

P-2040 FULL ASSEMBLY & INTERIOR

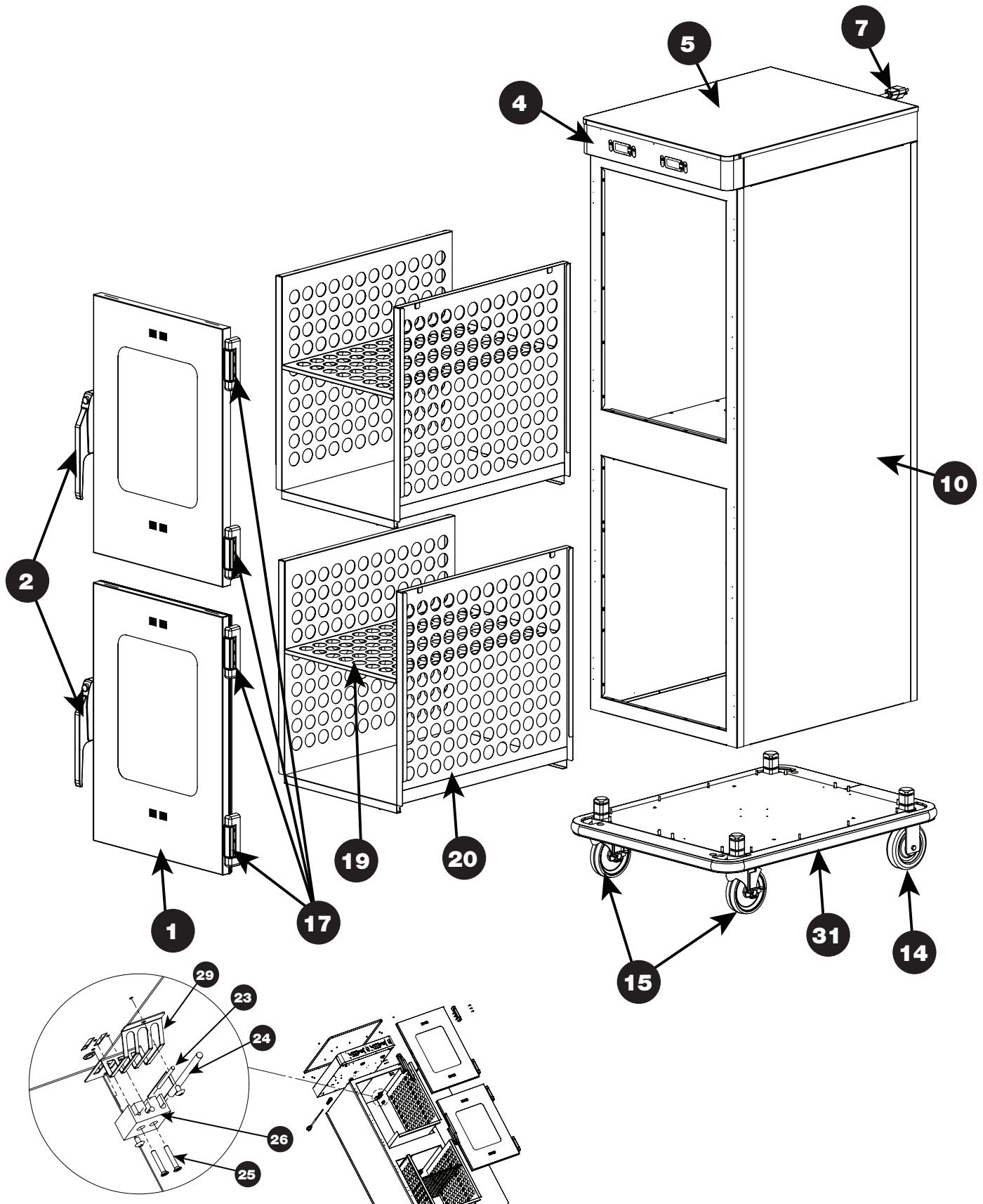

PART NUMBERS AND DRAWINGS ARE SUBJECT TO CHANGE WITHOUT NOTICE.

# SERVICE

## P-2055 FULL ASSEMBLY & INTERIOR

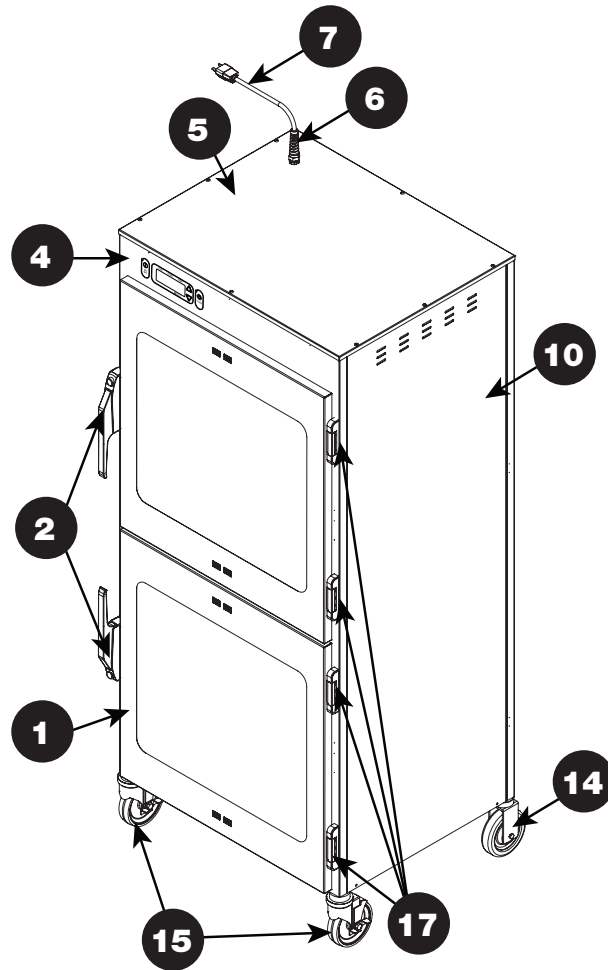

### 18 BLANKET INSERT ASSEMBLY

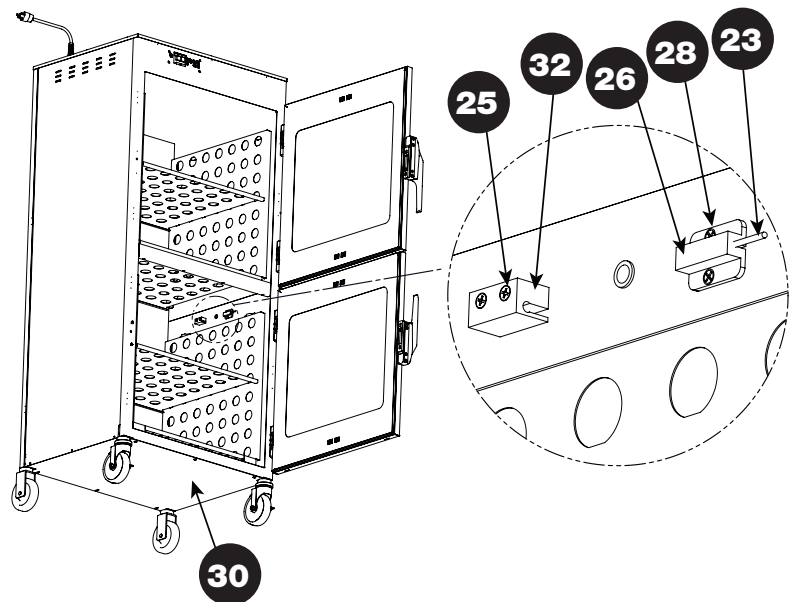
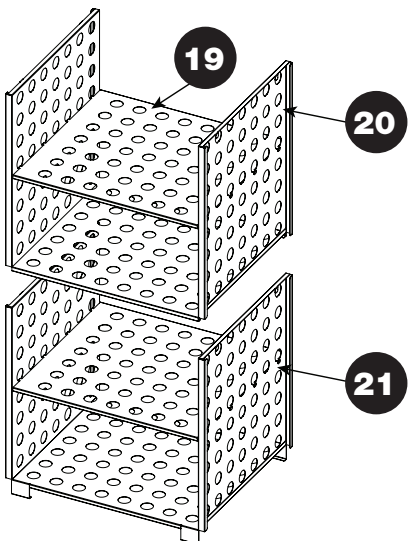

PART NUMBERS AND DRAWINGS ARE SUBJECT TO CHANGE WITHOUT NOTICE.

## SERVICE

LOC	DESCRIPTION	QTY	P-2010	QTY	P-2020	QTY	P-2030	QTY	P-2040	QTY	P-2055
1.	CONTROL ASSEMBLY	1	CC-34765*	1	CC-34765*	1	CC-34765	2	CC-34765	1	CC-34765
2.	NUT, #8-32 UNC	4	NU-26526	4	NU-26526	4	NU-26526	8	NU-26526	4	NU-26526
3.	CONNECTOR, 10 PIN	1	CR-33717*	1	CR-33717*	1	CR-33717	2	CR-33717	1	CR-33717
4.	CONNECTOR, 9 PIN	1	CR-33718*	1	CR-33718*	1	CR-33718	2	CR-33718	1	CR-33718
5.	BEEPER, SOLID STATE	1	BP-3567*	1	BP-3567*	1	BP-3567	1	BP-3567	1	BP-3567
6.	RELAY, 12V DC, COIL	1	RL-34434*	1	RL-34434*	1	RL-34434	2	RL-34434	1	RL-34434
7.	SCREW, 6/32 X 3/4" PAN FLAT-HEAD	1	SC-2146*	1	SC-2146*	1	SC-2146*	2	SC-2146*	2	SC-2146*
8.	TERMINAL BLOCK, PORCELAIN	1	BK-33546*	1	BK-33546*	1	BK-33546*	2	BK-33546*	2	BK-33546
9.	POWER SUPPLY BOARD	1	BA-34041*	1	BA-34041*	1	BA-34041	1	BA-34041	1	BA-34041
10.	TERMINAL BLOCK, 3 FORM COMPRESS	1	BK-3019*	1	BK-3019*	1	BK-3019	1	BK-3019	1	BK-3019
11.	THERMOSTAT, MANUAL RESET	1	TT-33476*	1	TT-33476*	1	TT-33476	1	TT-33476	1	TT-34600
11B.		—	—	—	—	—	—	1	TT-34600	—	—
12.	HI-LIMIT PROTECTION COVER	1	1009751*	1	1009751*	1	1009751	1	1009751	1	1009751
13.	SCREWS, M4-0.7X6MM PHIL	2	SC-22271*	2	SC-22271*	2	SC-22271	4	SC-22271	2	SC-22271
14.	CIRCUIT BREAKER SWITCH	1	SW-33826*	1	SW-33826*	1	SW-33826	1	SW-33858	1	SW-33858
15.	STRAIN RELIEF BUSHING	1	BU-34836*	1	BU-34836*	1	BU-34836*	1	BU-34836*	1	BU-34836*
16.	CORDSET, HOSPITAL GRADE, 10FT (3m)*	1	E3025CD	1	E3025CD	1	E3025CD	1	E3029CD	1	E3029CD
18.	CONNECTOR, 4 POS*	1	CR-34065	1	CR-34065	1	CR-34065	2	CR-34065	2	CR-34065
19.	CONNECTOR, 5 POS*	1	CR-34066	1	CR-34066	1	CR-34066	2	CR-34066	2	CR-34066
20.	CONNECTOR, TERMINAL*	2	CR-3806	2	CR-3806	2	CR-3806	2	CR-3806	2	CR-3806
21.	DOOR SWITCH*	1	SW-33559†	1	SW-33559†	1	SW-33559†	1	SW-33559†	2	SW-33559
22.	SCREW, 10-32 X 1/4" PAN, GROUND SCREW*	1	SC-2190	1	SC-2190	1	SC-2190	1	SC-2190	1	SC-2190
23.	THERMOSTAT, AUTO RESET*	1	TT-34350	1	TT-34350	1	TT-34350	2	TT-34350	1	TT-36490
24.	RIVETS*	2	RI-27108	2	RI-27108	2	RI-27108	4	RI-27108	2	RI-27108
25.	WIRE DIAGRAM* (LOCATED UNDER TOP COVER)	1	E7015	1	7745	1	7789	1	7756	1	77563

\* NOT SHOWN † OPTIONAL

### P-2010, P-2020, P-2030 ELECTRICAL (P-2030 SHOWN)

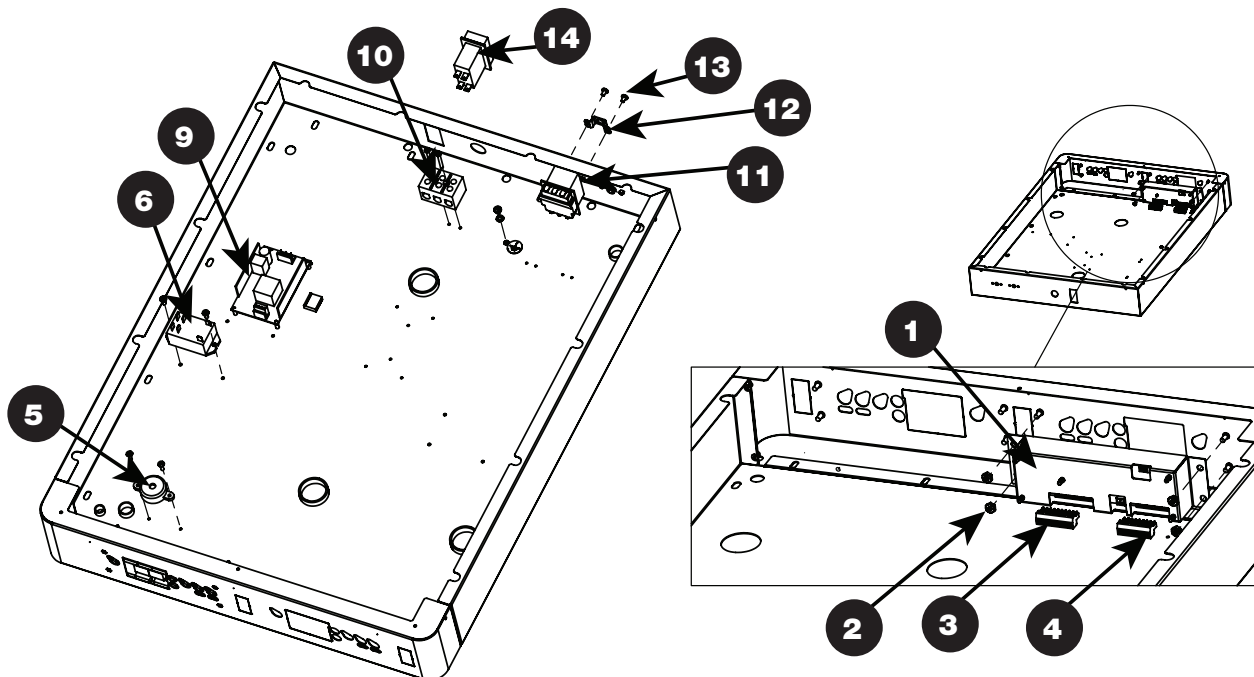

PART NUMBERS AND DRAWINGS ARE SUBJECT TO CHANGE WITHOUT NOTICE.

**SERVICE**

**P-2040 ELECTRICAL**

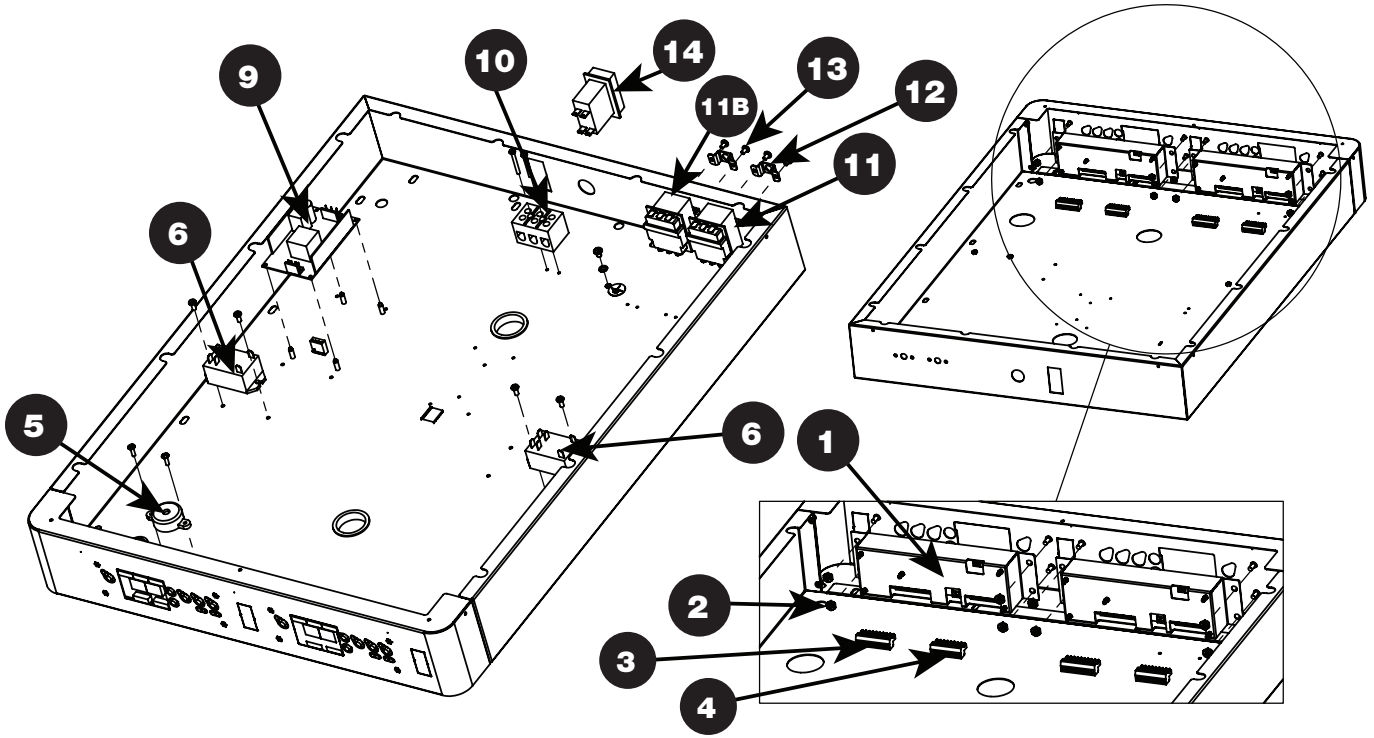

**P-2055 ELECTRICAL**

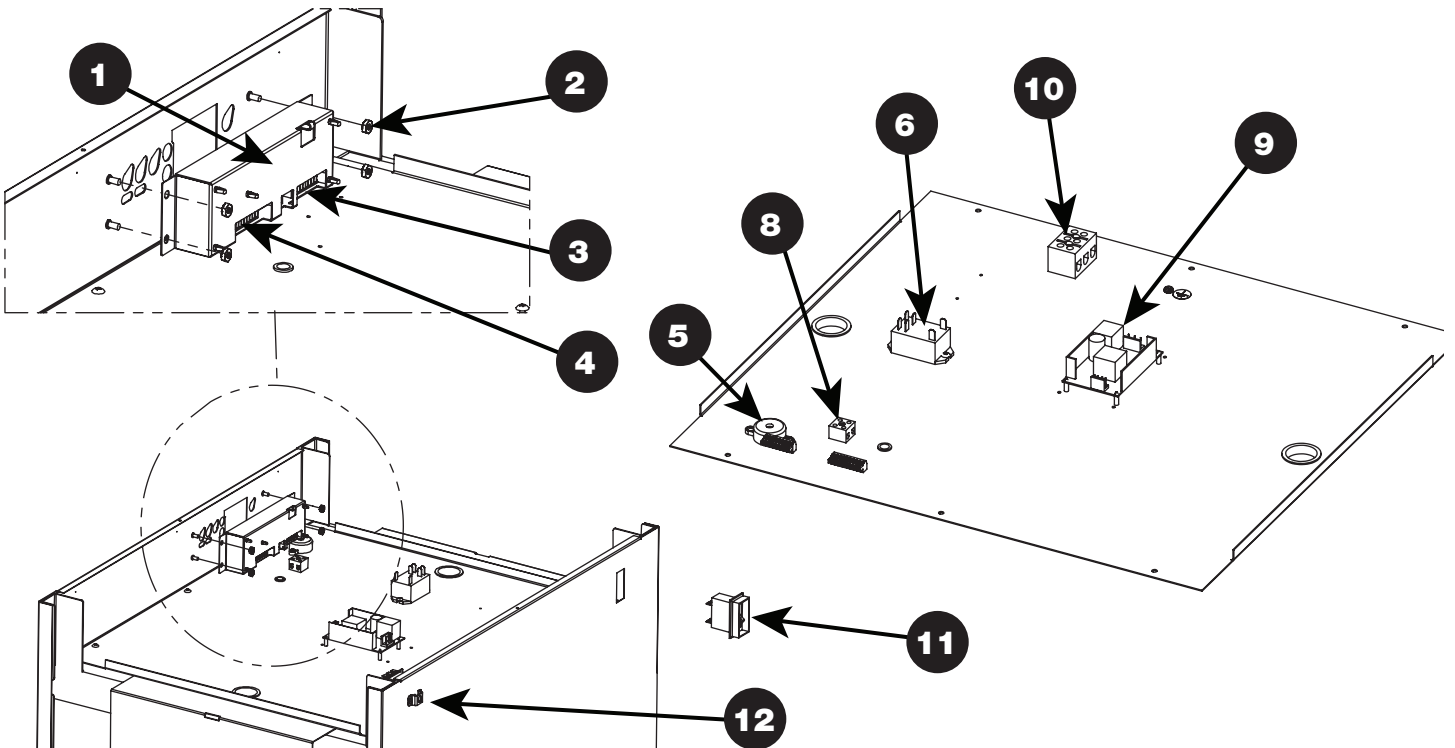

PART NUMBERS AND DRAWINGS ARE SUBJECT TO CHANGE WITHOUT NOTICE.

## SERVICE

### OPTIONS & ACCESSORIES PARTS LIST \*

\*NOT SHOWN

OPTIONS AND ACCESSORIES	P-2010	P-2020	P-2030	P-2040	P-2055
Built-in Trim Kit, Reach-In	—	—	CONTACT FACTORY	5013889	5013968
Built-in Trim Kit, Pass-through	—	—	—	5013889 (x2)	5013968 (x2)
Casters, 3.5" (89mm) <span style="float: right;">PLATE, RIGID</span>	CS-23731	—	—	—	—
<span style="float: right;">PLATE, SWIVEL W/ BRAKE</span>	CS-23730	—	—	—	—
<span style="float: right;">SCREW (4 REQUIRED FOR EACH CASTER)</span>	SC-2351	—	—	—	—
Casters, 5" (127mm) <span style="float: right;">PLATE, RIGID</span>	CS-2025	CS-2025	—	—	—
<span style="float: right;">PLATE, SWIVEL W/ BRAKE</span>	CS-2026	CS-2026	—	—	—
<span style="float: right;">SCREW (4 REQUIRED FOR EACH CASTER)</span>	SC-2351	SC-2351	—	—	—
Full-perimeter Rubber Bumper <span style="float: right;">20.4" x 28.1" (518mm x 714mm)</span>	—	5010798	—	—	—
(WxD) <span style="float: right;">25.2" x 33.1" (640mm x 841mm)</span>	—	—	5015440	5015440	—
Leg Kit, 6" (152mm)	5017044	5017084	5017084	5017084	5017084
Lock for Door Handle	LK-22567	LK-22567	LK-22567	LK-22567	LK-22567
Solid Door Assembly	5009920	5012610	5012572	5012572	5016247
<b>STACKING HARDWARE</b>					
P-2010 over P-2010 or P-2110	5012145	—	—	—	—
P-2010 over P-2020 or P-2120	—	5012146	—	—	—
P-2010 over P-2030 or P-2130	—	—	5012148	—	—
P-2020 over P-2020 or P-2120	—	5012153	—	—	—
P-2020 over P-2030 or P-2130	—	—	5012149	—	—
P-2030 over P-2030 or P-2130	—	—	5011588	—	—

### HEATING CABLE REPLACEMENT KITS \*

\*NOT SHOWN

		P-2010	P-2020	P-2030	P-2040	P-2055
<b>CABLE REPLACEMENT KIT NUMBER</b>		<b>4877</b>	<b>4880</b>	<b>4874</b>	<b>4874</b> (1 kit/chamber)	<b>4881</b>
<b>SERVICE KIT INCLUDES:</b>						
CB-3045	CABLE HEATING ELEMENT	37 ft (11m)	134 ft (41m)	108 ft (33m)	108 ft (33m)	210 ft (64m)
BU-3106	CUP BUSHING	2	8	4	4	12
TA-3540	ELECTRICAL TAPE	1 ROLL	1 ROLL	1 ROLL	1 ROLL	1 ROLL
NU-2215	HEX NUT	4	8	8	8	24
IN-3488	INSULATION CORNER	8 ft (2m)	8 ft (2m)	8 ft (2m)	8 ft (2m)	8 ft (2m)
SL-3063	INSULATING SLEEVE	2	4	4	4	12
CR-3226	RING CONNECTOR	2	4	4	4	12
BU-3105	SHOULDER BUSHING	2	4	4	4	12
ST-2439	STUD, 10-32	2	4	4	4	12

PART NUMBERS AND DRAWINGS ARE SUBJECT TO CHANGE WITHOUT NOTICE.



Refer to wire diagram included with the unit.

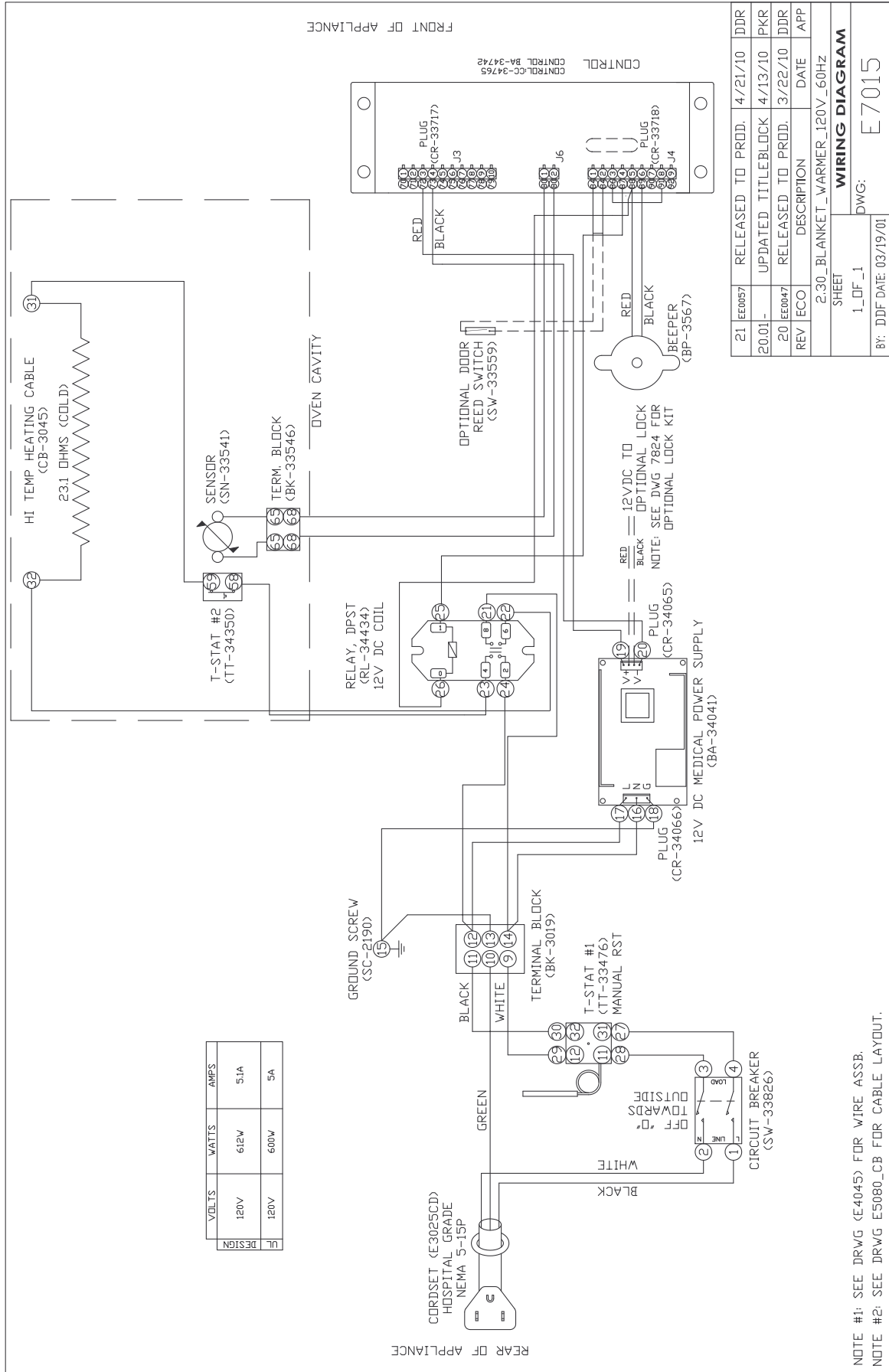

VOLTS	WATTS	AMPS
120V	612W	5.1A
120V	600W	5A

UL DESIGN

21	EE0057	RELEASED TO PRODD.	4/21/10	DDR
20.01		UPDATED TITLEBLOCK	4/13/10	PKR
20	EE0047	RELEASED TO PRODD.	3/22/10	DDR
REV	ECO	DESCRIPTION	DATE	APP
2:30_BLANKET_WARMER_120V_60HZ				
SHEET				
1_OF_1				
BY: DDF DATE: 03/19/01				
DWG: E7015				
WIRING DIAGRAM				

NOTE #1: SEE DRWG (E4045) FOR WIRE ASSB.  
 NOTE #2: SEE DRWG E5080\_CB FOR CABLE LAYOUT.

Refer to wire diagram included with the unit.

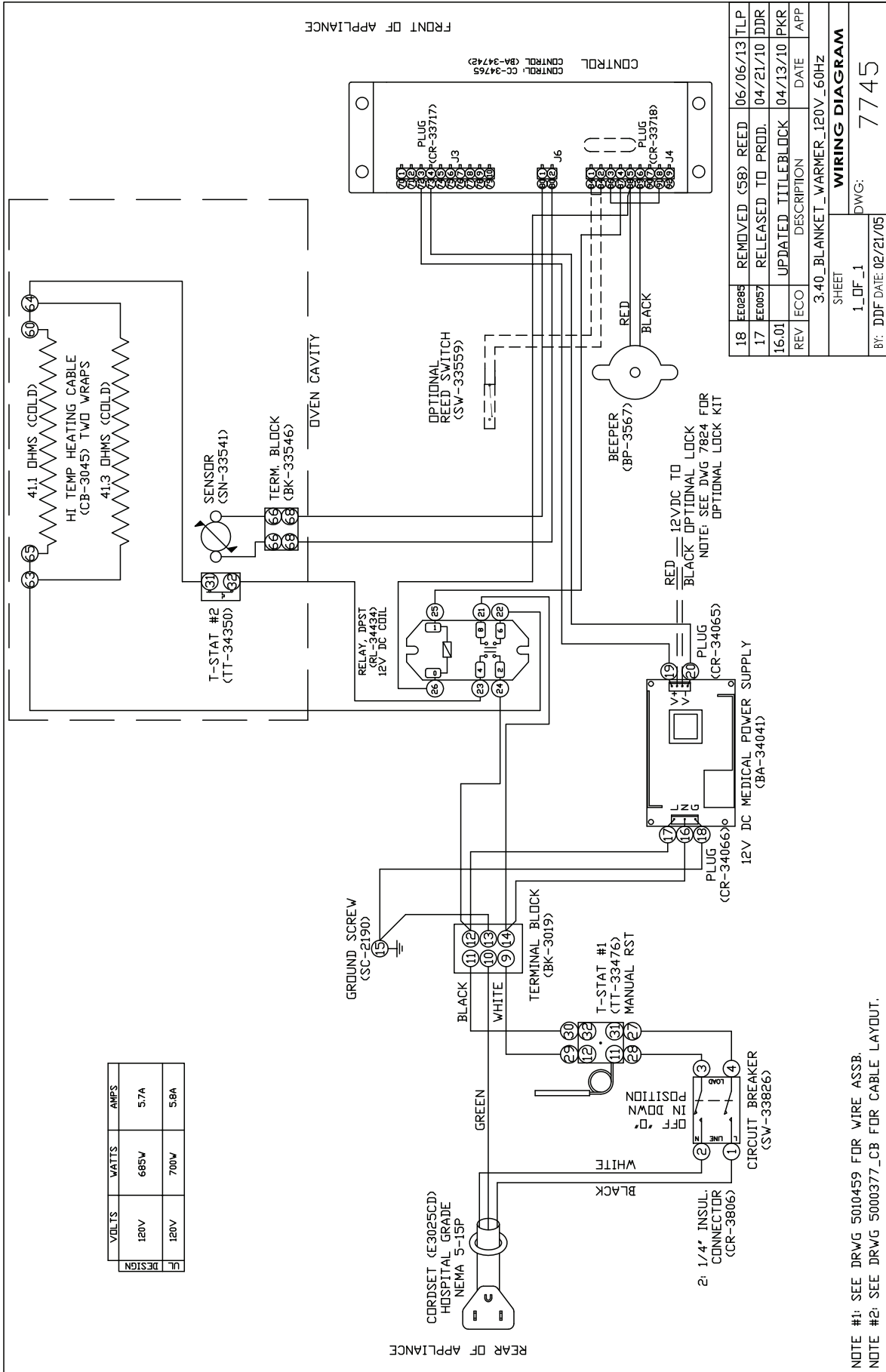

18	EE0285	REMOVED (58)	REED	06/06/13	TLP
17	EE0057	RELEASED TO PROD.		04/21/10	DDR
16.01		UPDATED TITLEBLOCK		04/13/10	PKR
REV	ECO	DESCRIPTION	DATE	APP	
3-40_BLANKET_WARMER_120V_60Hz					
SHEET					
1_DF_1					
BY: DDF DATE: 02/21/05					
DWG: 7745					
WIRING DIAGRAM					

NOTE #1: SEE DRWG 5010459 FOR WIRE ASSB.  
 NOTE #2: SEE DRWG 5000377\_CB FOR CABLE LAYOUT.

Refer to wire diagram included with the unit.

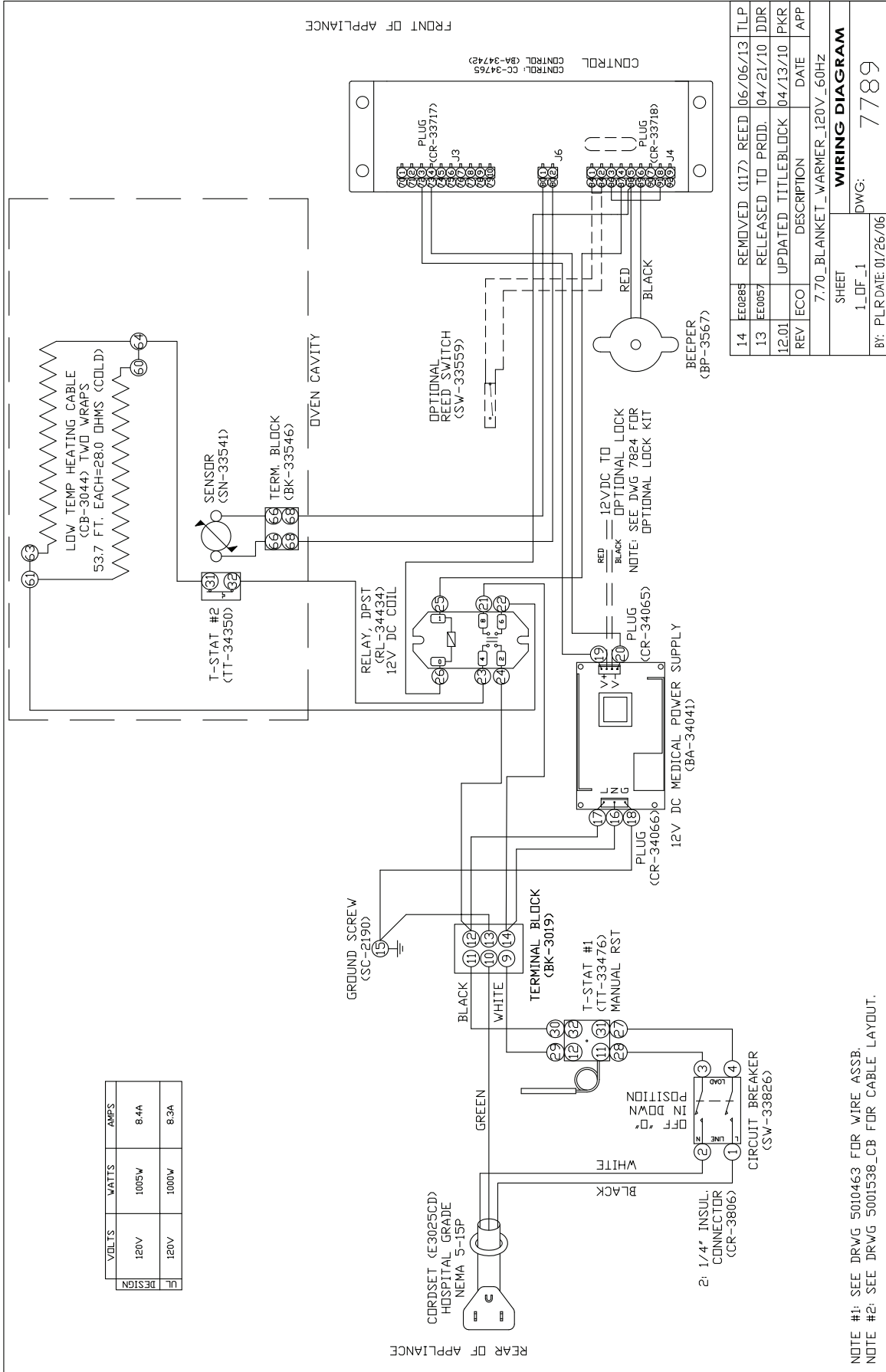

14	EC0285	REMOVED (117)	REED	06/06/13	TLP
13	EE0057	RELEASED TO PRDD.		04/21/10	DDR
12	01	UPDATED TITLE BLOCK		04/13/10	PKR
REV	ECO	DESCRIPTION	DATE	APP	
7.70_BLANKET_WARMER_120V_60HZ					
<b>WIRING DIAGRAM</b>					
SHEET					
1_DF_1					
DWG: 7789					
BY: PLR DATE: 01/26/06					

NOTE #1: SEE DRWG 5010463 FOR WIRE ASSB.  
 NOTE #2: SEE DRWG 5001538\_CB FOR CABLE LAYOUT.

Refer to wire diagram included with the unit.

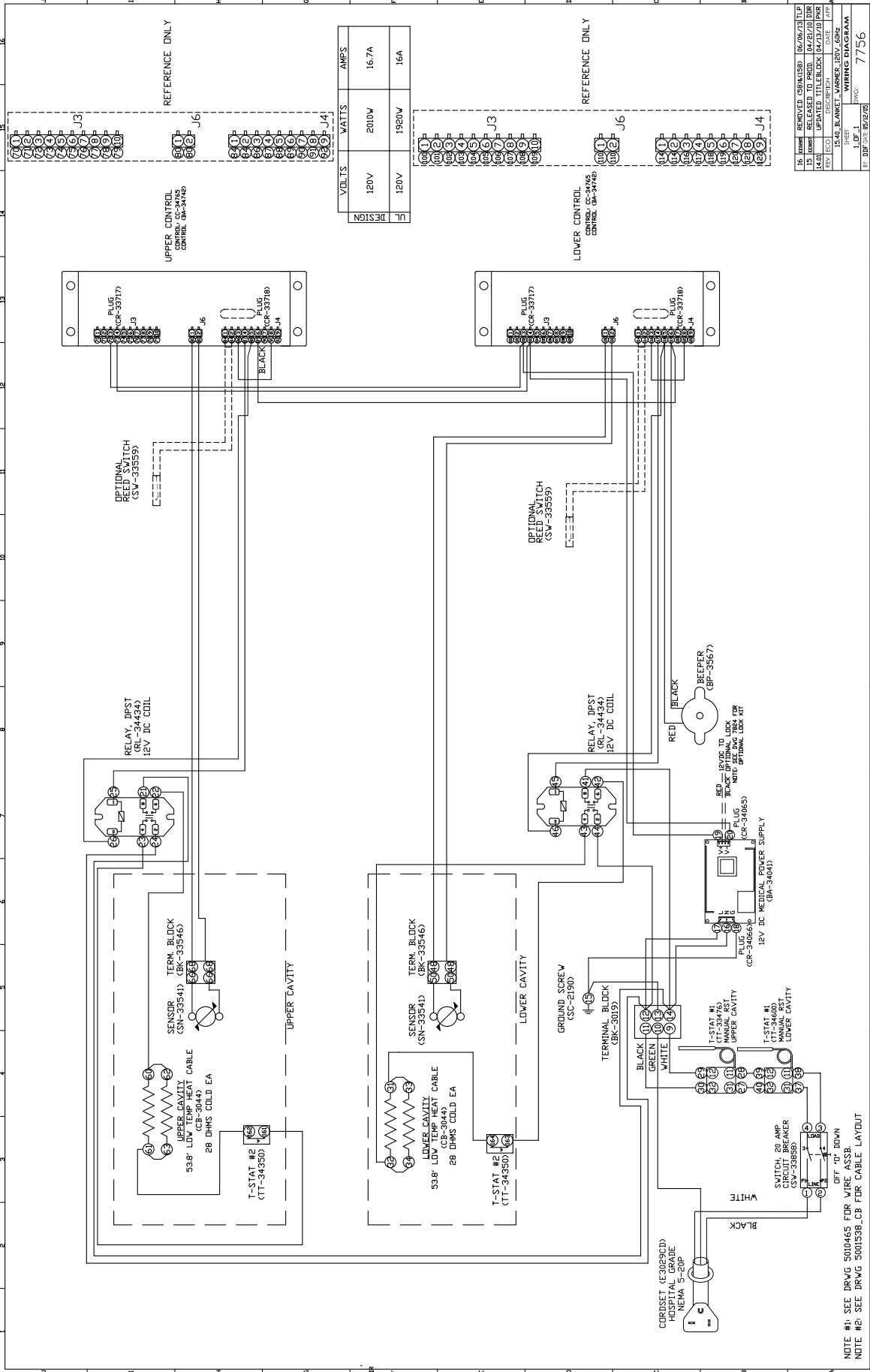

Refer to wire diagram included with the unit.

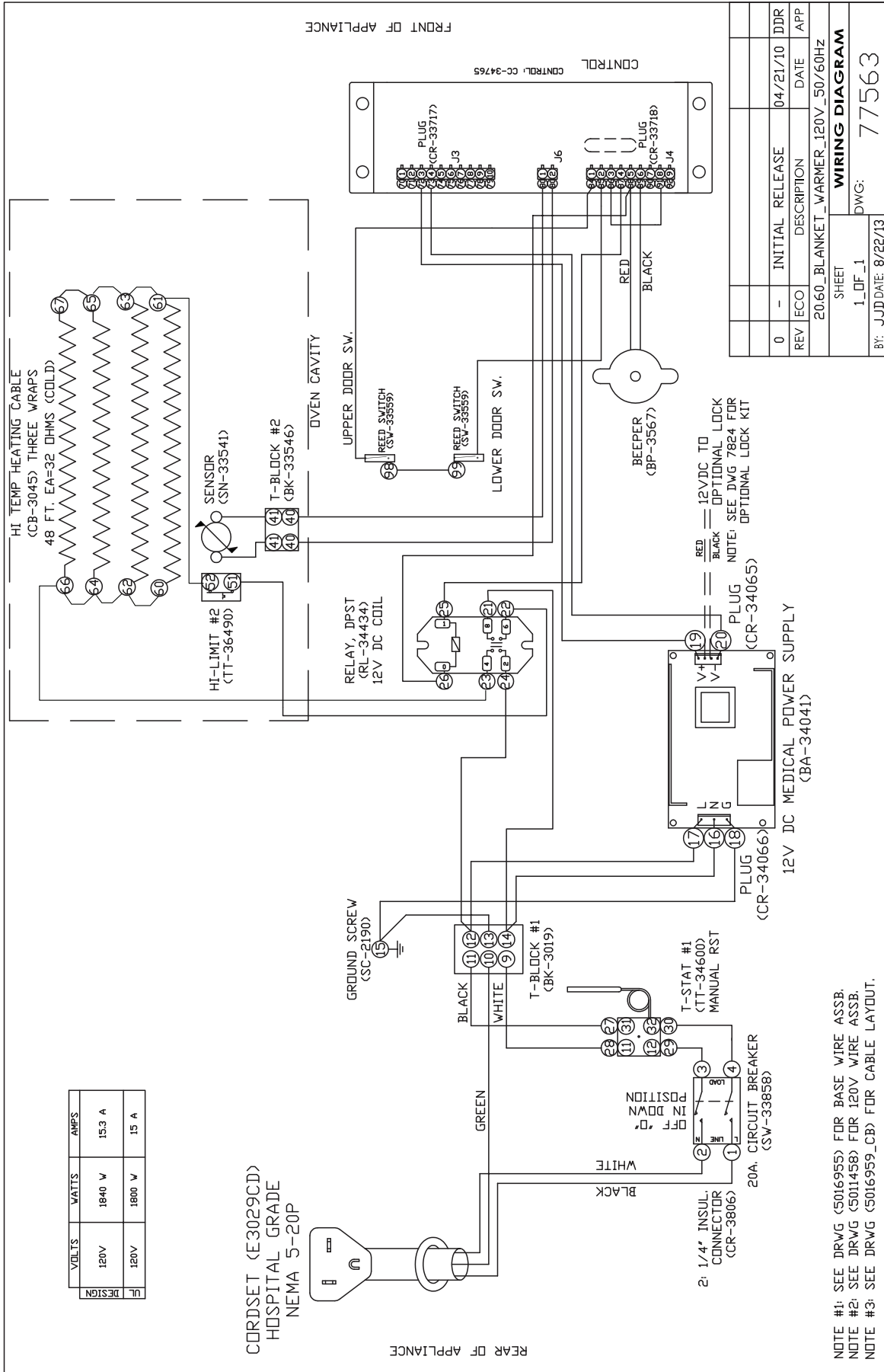

## TRANSPORTATION DAMAGE AND CLAIMS



All Pedigo Products, Inc. equipment is sold F.O.B. shipping point, and when accepted by the carrier, such shipments become the property of the consignee.

Should damage occur in shipment, it is a matter between the carrier and the consignee. In such cases, the carrier is assumed to be responsible for the safe delivery of the merchandise, unless negligence can be established on the part of the shipper.

1. Make an immediate inspection while the equipment is still in the truck or immediately after it is moved to the receiving area. Do not wait until after the material is moved to a storage area.
2. Do not sign a delivery receipt or a freight bill until you have made a proper count and inspection of all merchandise received.
3. Note all damage to packages directly on the carrier's delivery receipt.
4. Make certain the driver signs this receipt. If he refuses to sign, make a notation of this refusal on the receipt.
5. If the driver refuses to allow inspection, write the following on the delivery receipt:

*Driver refuses to allow inspection of containers for visible damage.*

6. Telephone the carrier's office immediately upon finding damage, and request an inspection. Mail a written confirmation of the time, date, and the person called.
7. Save any packages and packing material for further inspection by the carrier.
8. Promptly file a written claim with the carrier and attach copies of all supporting paperwork.

We will continue our policy of assisting our customers in collecting claims which have been properly filed and actively pursued. We cannot, however, file any damage claims for you, assume the responsibility of any claims, or accept deductions in payment for such claims.

## PEDIGO PRODUCTS, INC. LIMITED WARRANTY

Pedigo Products, Inc. warrants to the original purchaser that any original part that is found to be defective in material or workmanship will, at our option, subject to provisions hereinafter stated, be replaced with a new or rebuilt part.

The labor warranty remains in effect one (1) year from installation or fifteen (15) months from the shipping date, whichever occurs first.

The original parts warranty for the cavity fan motor remains in effect one (1) year from installation of appliance or fifteen (15) months from the shipping date, whichever occurs first. The original parts warranty on all other parts remains in effect three (3) years from installation of appliance or thirty-nine (39) months from the shipping date, whichever occurs first.

This warranty does not apply to:

1. Calibration
2. Equipment damage caused by accident, shipping, improper installation or alteration.
3. Equipment used under conditions of abuse, misuse, carelessness or abnormal conditions including equipment subjected to harsh or inappropriate chemicals including but not limited to compounds containing chloride or quaternary salts, poor water quality, or equipment with missing or altered serial numbers.
4. Any losses or damage resulting from malfunction, including loss of contents or consequential or incidental damages of any kind.
5. Equipment modified in any manner from original model, substitution of parts other than factory authorized parts, removal of any parts including legs, or addition of any parts.
6. Collateral or incidental damage as a direct result of servicing equipment built into a wall structure is not covered under warranty. It is the responsibility of the owner to bear all expense related to structural repairs including, but not limited to, external electrical connections and wiring, and the removal or replacement of caulk, grout, tile, or wall covering of any kind. A service access panel for built-in equipment installations is strongly recommended.

This warranty is exclusive and is in lieu of all other warranties, expressed or implied, including the implied warranties of merchantability and fitness for purpose. In no event shall the Company be liable for loss of use, loss of revenue, or loss of contents or revenue, or for indirect or consequential damages. This warranty is in lieu of all other warranties expressed or implied and Pedigo Products, Inc. neither assumes or authorizes any persons to assume for it any other obligation or liability in connection with Pedigo Products, Inc. equipment.

### Pedigo Products, Inc.

Record the model and serial numbers of the unit for easy reference. Always refer to both model and serial numbers in your correspondence regarding the unit.

Model: \_\_\_\_\_  
Serial Number: \_\_\_\_\_  
Purchased From: \_\_\_\_\_  
Date Installed: \_\_\_\_\_ Voltage: \_\_\_\_\_

Warranty Effective November 1, 2012



**Pedigo Products, Inc**  
4000 S.E. Columbia Way • Vancouver, WA 98661 • U.S.A.  
Phone: 800.822.3501 • Fax: 360.696.1700 • [www.pedigo-usa.com](http://www.pedigo-usa.com)