

PARTS LIST			
ITEM	PART#	DESCRIPTION	NOTES
1	1899	Snap Frame	
2	1896	Snap Frame Radius Cover	
3	5892	Snap Frame Spring	
4	5890	2Piece Corner Key	3 Pieces - Front, Set Screws & Back

Ship To:
Sales Order#:

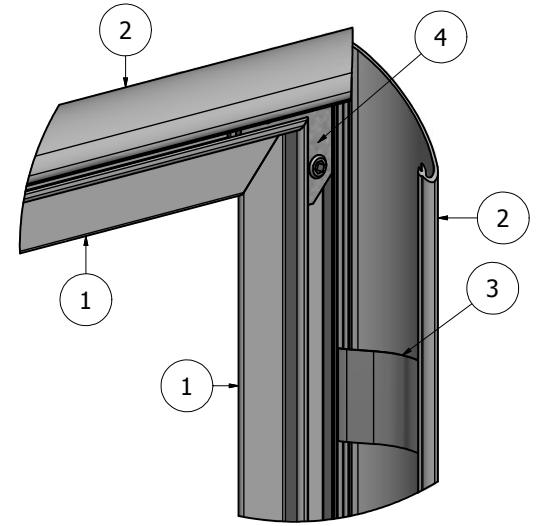

DETAIL A

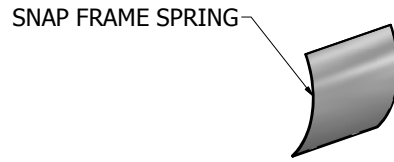
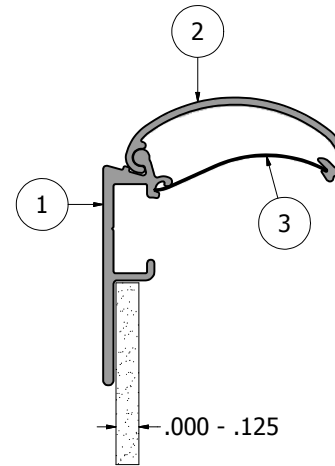

CROSS-SECTION OPEN

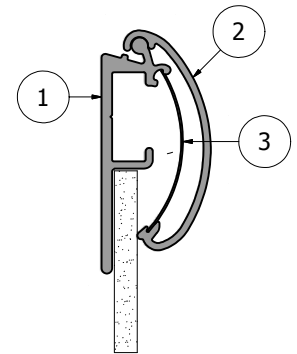

CROSS-SECTION CLOSED

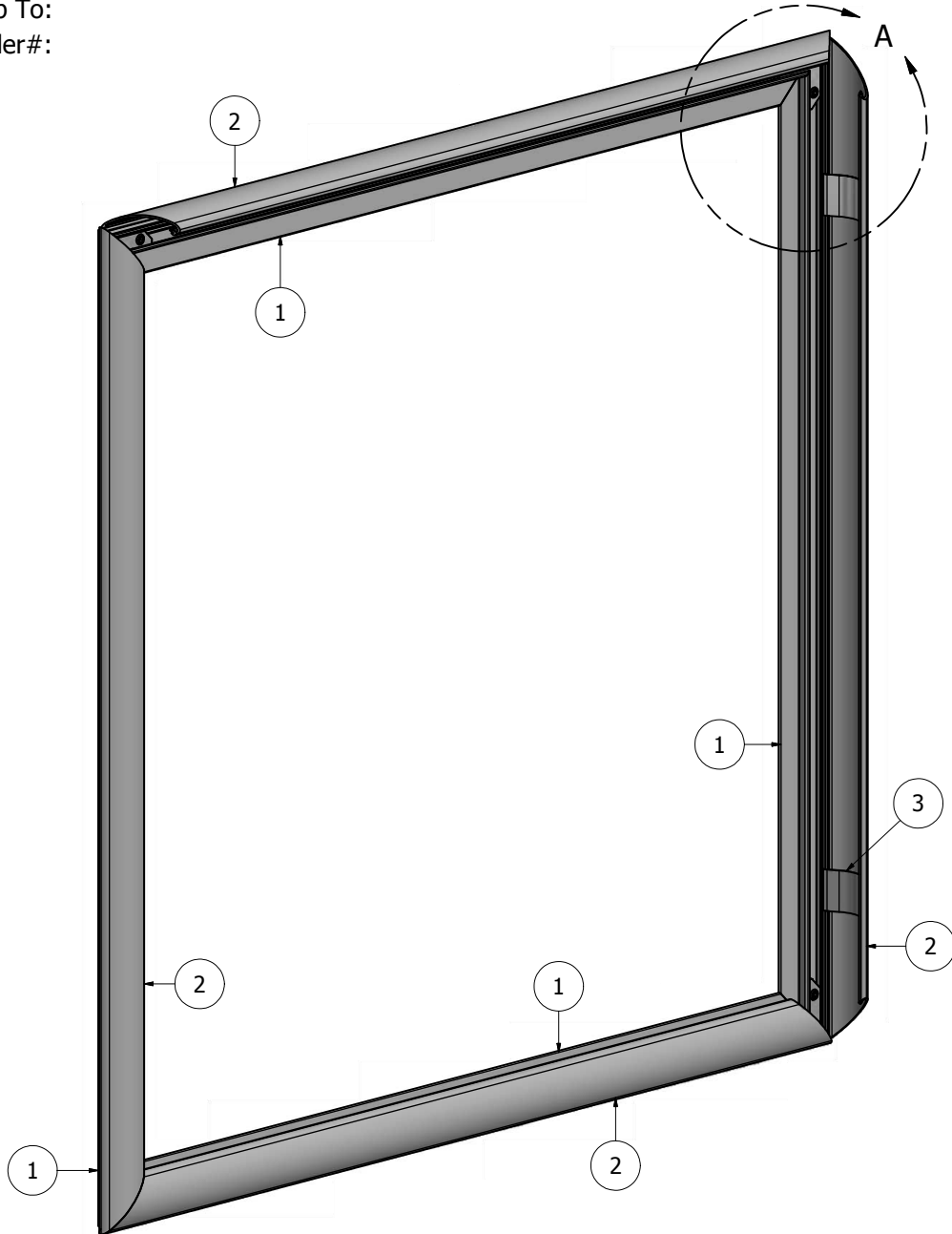

THIS DRAWING WAS CREATED AT NO CHARGE TO ASSIST YOU IN VISUALIZING OUR PROPOSAL. THE DRAWING HEREIN IS THE PROPERTY OF SIGNCOMP. PERMISSION TO COPY OR REVISE THIS DRAWING OR TO USE THIS DRAWING FOR PRODUCTION IS STRICTLY PROHIBITED AND CAN ONLY BE COPIED, REVISED OR USED FOR PRODUCTION WITH THE EXPRESSED WRITTEN PERMISSION OF SIGNCOMP.

DRAWN	SBreihof	8/30/2012
Centroid X:	0.000 in	
Centroid Y:	0.000 in	
Principal Moments Ix:	0.000 in ⁴	
Principal Moments Iy:	0.000 in ⁴	
Section Modulus Ix:	0.000 in ³	
Section Modulus Iy:	0.000 in ³	

SignComp

TITLE
Snap Frame with Radius Snap Frame Cover - Assumbly

DWG NO **K1899/1896** REV

PARTS LIST			
ITEM	PART#	DESCRIPTION	NOTES
1	1899	Snap Frame	
2	5890	2Piece Corner Key	Threaded Angle, Back Plate & Set Screws

Ship To:
Sales Order#:

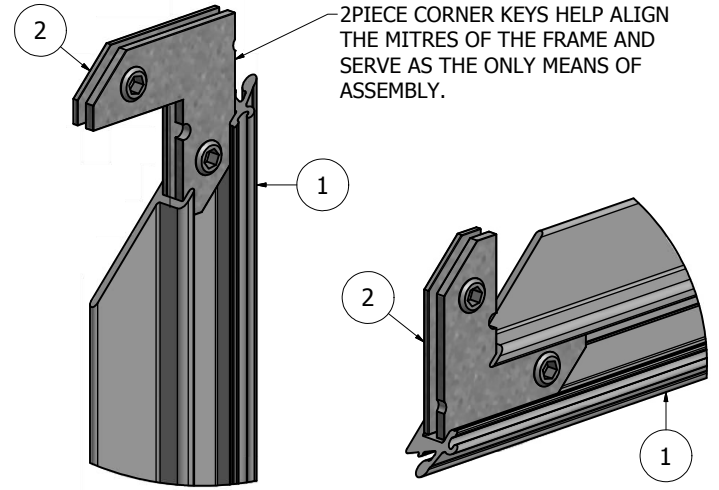
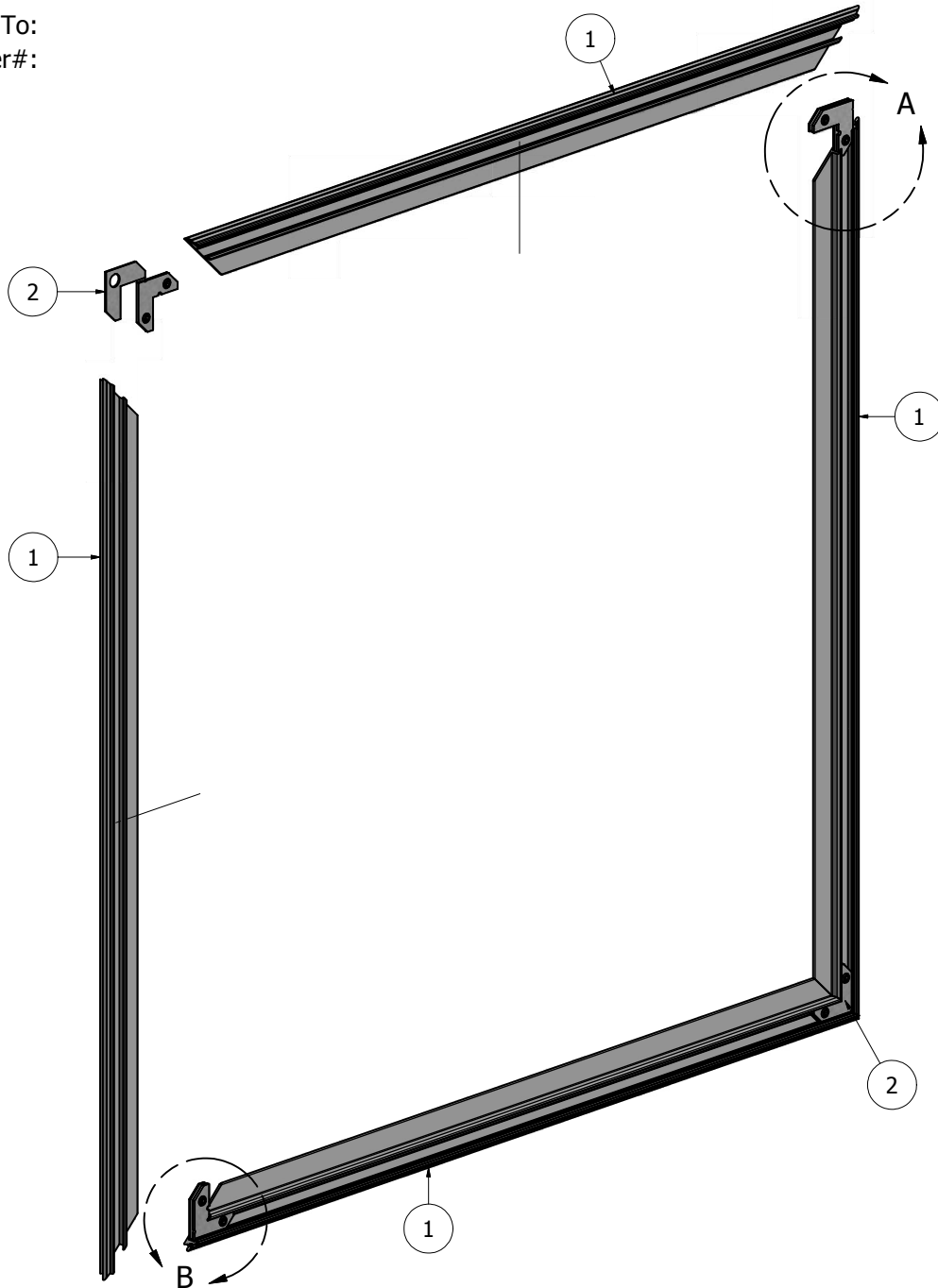

2PIECE CORNER KEYS HELP ALIGN THE MITRES OF THE FRAME AND SERVE AS THE ONLY MEANS OF ASSEMBLY.

DETAIL A

DETAIL B

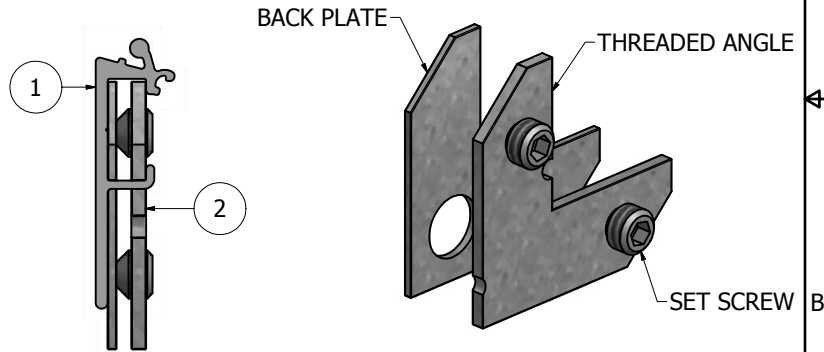

CROSS-SECTION VIEW

BACK PLATE
THREADED ANGLE
SET SCREW

ALIGN THE BACK PLATE AND ANGLE THEN SLIDE INTO THE CHANNEL OF THE FRAME. THE APPLIED PRESSURE BY TIGHTENING THE SET SCREWS, SEPARATES THE ANGLES SECURING THEM IN THE FRAME CHANNEL.

THIS DRAWING WAS CREATED AT NO CHARGE TO ASSIST YOU IN VISUALIZING OUR PROPOSAL. THE DRAWING HEREIN IS THE PROPERTY OF SIGNCOMP. PERMISSION TO COPY OR REVISE THIS DRAWING OR TO USE THIS DRAWING FOR PRODUCTION IS STRICTLY PROHIBITED AND CAN ONLY BE COPIED, REVISED OR USED FOR PRODUCTION WITH THE EXPRESSED WRITTEN PERMISSION OF SIGNCOMP.

DRAWN	SBreihof	8/30/2012	SignComp	
Centroid X:	0.000 in			
Centroid Y:	0.000 in		Snap Frame - Assembly	
Principal Moments Ix:	0.000 in ⁴			
Principal Moments Iy:	0.000 in ⁴		DWG NO	REV
Section Modulus Ix:	0.000 in ³		K1899	
Section Modulus Iy:	0.000 in ³		SHEET 1 OF 1	