

# Installation and Operation Manual

## 40 Yard Binhouse

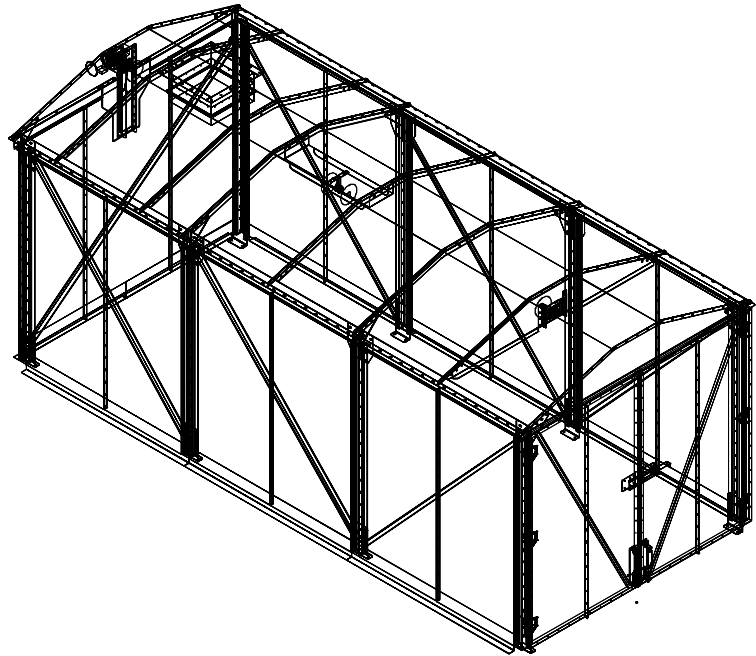

Throughout this manual statements indicating precautions necessary to avoid equipment failure are referenced in a **Note**. Statements indicating potential hazards that could result in *personal injury* or *property damage* are referenced in a **CAUTION!** box.

*Illustrations are for reference only, as actual product may vary.*

This manual is property of the owner. Leave with the unit when set-up and start-up are complete. Donaldson Company reserves the right to change design and specifications without prior notice.



## **CAUTION!**

### **Application of Dust Control Equipment**

- Combustible materials such as buffing lint, paper, wood, aluminum or steel dust, weld fume, or flammable solvents represent fire or explosion hazards. Use special care when selecting and operating all dust or fume collection equipment when combustible materials are present to protect workers and property from damage due to fire and/or explosion. Consult and comply with National and Local Codes relating to fire or explosion and all other appropriate codes when determining the location and operation of dust or fume collection equipment.
- When combustible materials are present, consult with an installer of fire extinguishing systems familiar with these types of fire hazards and local fire codes for recommendations and installation of fire extinguishing and explosion protection systems. Donaldson Torit dust collection equipment is not equipped with fire extinguishing or explosion protection systems.
- DO NOT allow sparks, cigarettes or other burning objects to enter the hood or duct of any dust or fume control equipment as these may initiate a fire or explosion.
- For optimum collector performance, use only Donaldson Torit replacement parts.

## Contents

Introduction .....	4
Shipping and Receiving.....	4
Safety .....	5
Assembly .....	6
Operation .....	16
Maintenance .....	16
Order Form .....	17
Warranty .....	20



This manual contains specific precautionary statements relative to worker safety. Read thoroughly and comply as directed. Discuss the use and application of this equipment with a Donaldson Torit representative. Instruct all personnel on safe use and maintenance procedures.

## Data Sheet

Model Number _____	Serial Number _____
Ship Date _____	Installation Date _____
Customer Name _____	
Address _____	
_____	
Filter Type _____	
Accessories _____	
Other _____	

## INTRODUCTION

Thank you for purchasing a Donaldson Torit binhouse. Your new binhouse is built to the highest industry standards. Great care has been taken to design and manufacture a high quality, low maintenance product that is economical to use and maintain.

This manual is intended to assist in the installation, operation and maintenance of your bin cover. Each situation dictates the need for any special precautions and it is the user's responsibility to ensure that adequate safety measures are employed in installation, operation and maintenance. As always, follow good safety practices around all equipment.

## SHIPPING AND RECEIVING

Donaldson Torit binhouse are shipped as completely assembled as transportation allows. Upon arrival inspect all components for damage that may have occurred during shipping. Check the bill of lading or packing list to verify the proper equipment and quantities. Should any discrepancies arise contact the carrier immediately.

Binhouses are equipped with lifting ears on the top section. Nylon straps with clevises should be attached at lifting ears and lifted using appropriate lifting equipment (i.e. crane).



### CAUTION!

- Misuse or modification of this equipment may result in personal injury.
- Do not misuse or modify.

# ***Safety First!***

## ***Read this before installing airlock.***

The Donaldson Torit binhouse like all commercial equipment must be used correctly and with common sense. The nature of any leveling auger is to run with exposed flighting in order to move the mound of material forward. Before servicing, changing out bins or inspecting bin turn off **and** lock out power to the leveling auger. Many systems employ sequencing that may allow a leveling auger to start without warning. It is imperative that all service and inspection be performed with the power turned off **and** locked out. Failure to do so may cause serious injury or death.

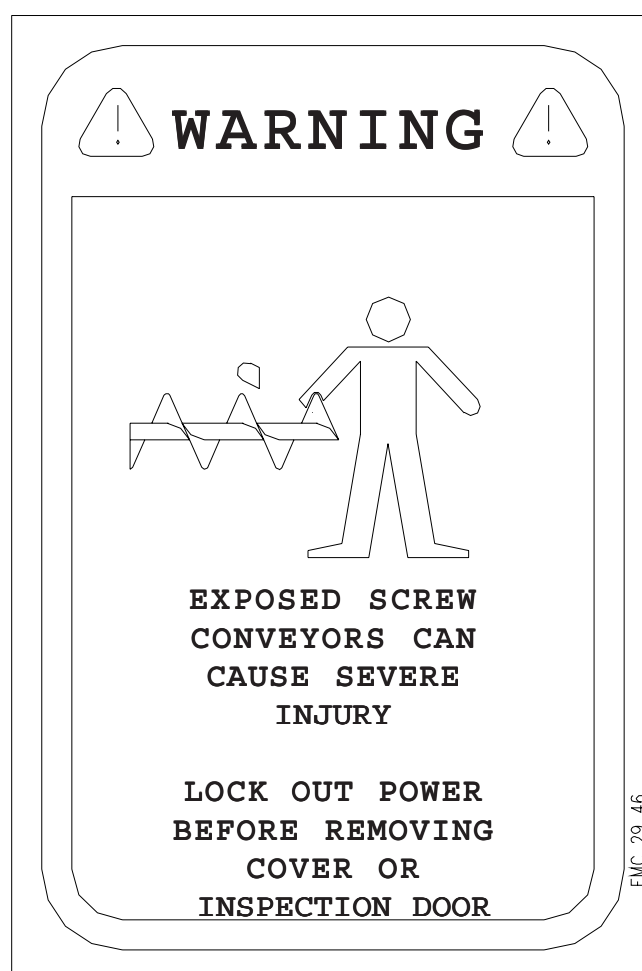

## Order of Assembly

This order of assembly is given as a general guide. Depending on your situation a different sequence may be more appropriate. This list is intended as a summary only.

### 1) Leg assembly

The binhouse is supported by 8 leg assemblies, two back, four mid and two front. The legs assemblies differ only in the clips attached to them. The legs and base clips are all identical. The front and back legs receive one 6 bolt roof mount clip while the mid legs receive two 3 bolt roof mount clips. There are two left-hand and two right-hand 6 bolt roof mount clips and four left-hand and four right-hand 3 bolt roof mount clips. The back legs also receive one angle brace clip. One clip is located on the 2nd and 3rd hole from the top of one leg while the other is located on the 2nd and 3rd hole from the bottom of the other leg. The front legs receive three hinge brackets located at the 1st, 8th and 15th hole from the top. Anchor to ground. Square and level the remaining legs but do not anchor at this time.



BACK LEG

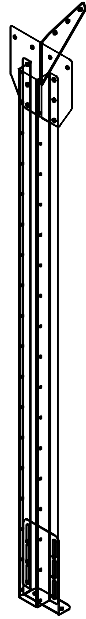

MID LEG

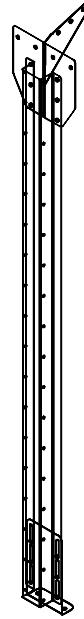

MID LEG

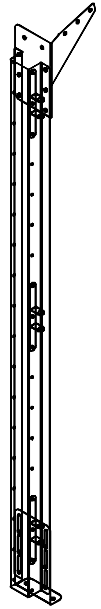

FRONT LEG

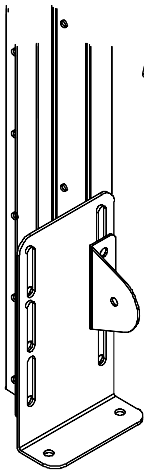

LOWER ANGLE  
CLIP ON LEFT  
BACK LEG

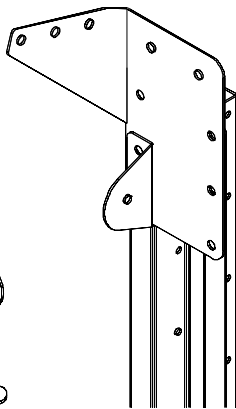

UPPER ANGLE  
CLIP ON RIGHT  
BACK LEG

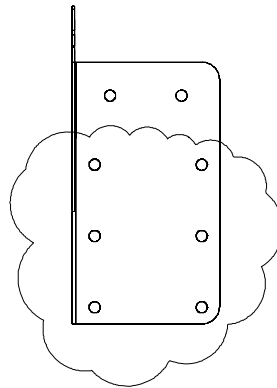

6 BOLT ROOF  
MOUNT CLIP

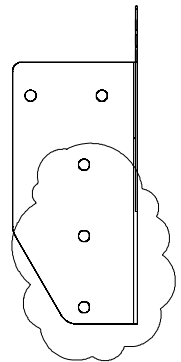

3 BOLT ROOF  
MOUNT CLIP

2) Locating binhouse

Typically the binhouse is located beneath the airlock discharge of a baghouse filter. The middle of the second roof panel from the back of the binhouse is located on center with the airlock discharge. This can be accomplished by lifting the binhouse top assembly into this position and then attaching the legs. An alternate method is to layout the position based on the template below. The binhouse infeed chute is cut in at the job site. This allows for adjustment in elevation as well as in plan. Use template for layout purpose only do not anchor feet at this time.

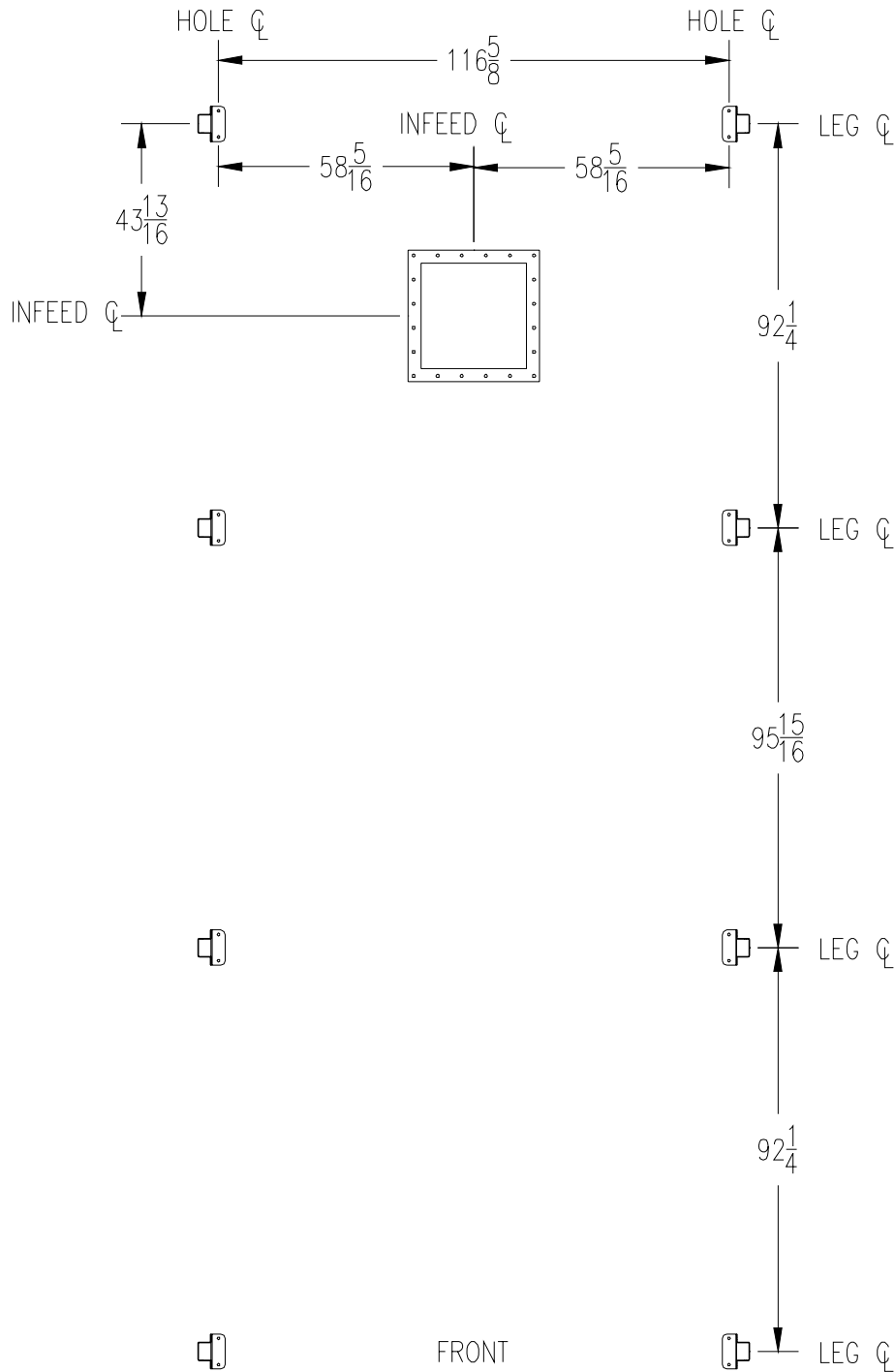

### 3) Attaching legs and braces

Attach the legs to the suspended top with three bolts at each joint. Leg to truss brackets mount on inside of trusses (see drawing below). Install the cross brace angle between legs as shown below. Tighten all roof mount clip bolts. Leave foot mount bolts finger tight. The binhouse is now ready to be leveled. Insure that binhouse leg placement is in desired position. Place a 3 ft. level across the top of the back roof panel from left to right. Adjust appropriate rear leg foot to level the back of the binhouse. Tighten back leg foot bolts and back angle brace bolts. Level the bin house back to front and tighten leg foot bolts and side angle braces.

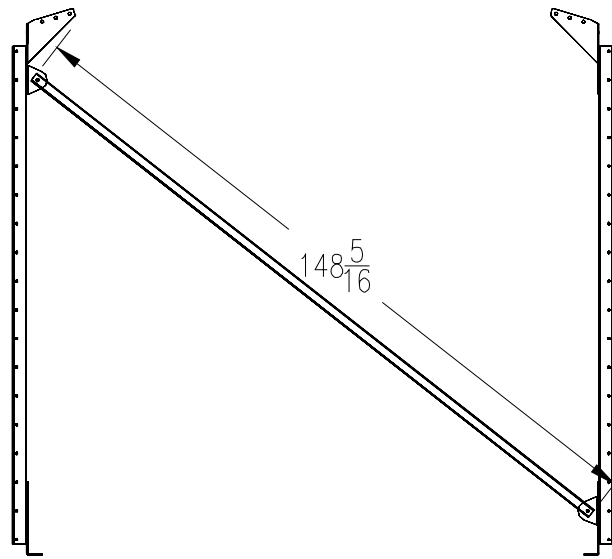

BACK ANGLE BRACE

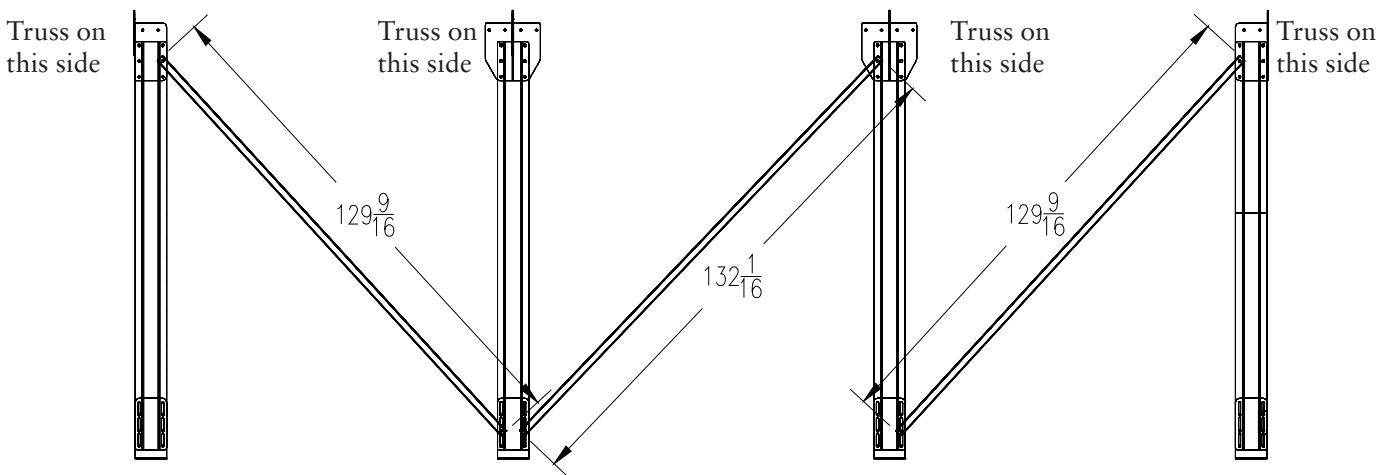

SIDE ANGLE BRACES



## 4) Attaching wall panels

Wall panels are attached to the legs and to each other with 3/8 x 1 hhcs. The end flanges on the panels are positioned to face into the binhouse to provide a smooth exterior appearance. There are 8 side end panels, 4 side mid panels, 1 center back panel, 1 left-hand rear corner panel and 1 right-hand rear corner panel. The flange nuts that are located at the ends of the legs and behind the foot bracket or roof mount bracket will require the use of a box end wrench to hold them in place so that the bolt may be threaded into them. Use of a drift pin or line up bar is helpful in getting the first bolts in place. Install all bolts hand tight first then after all are in place tighten.

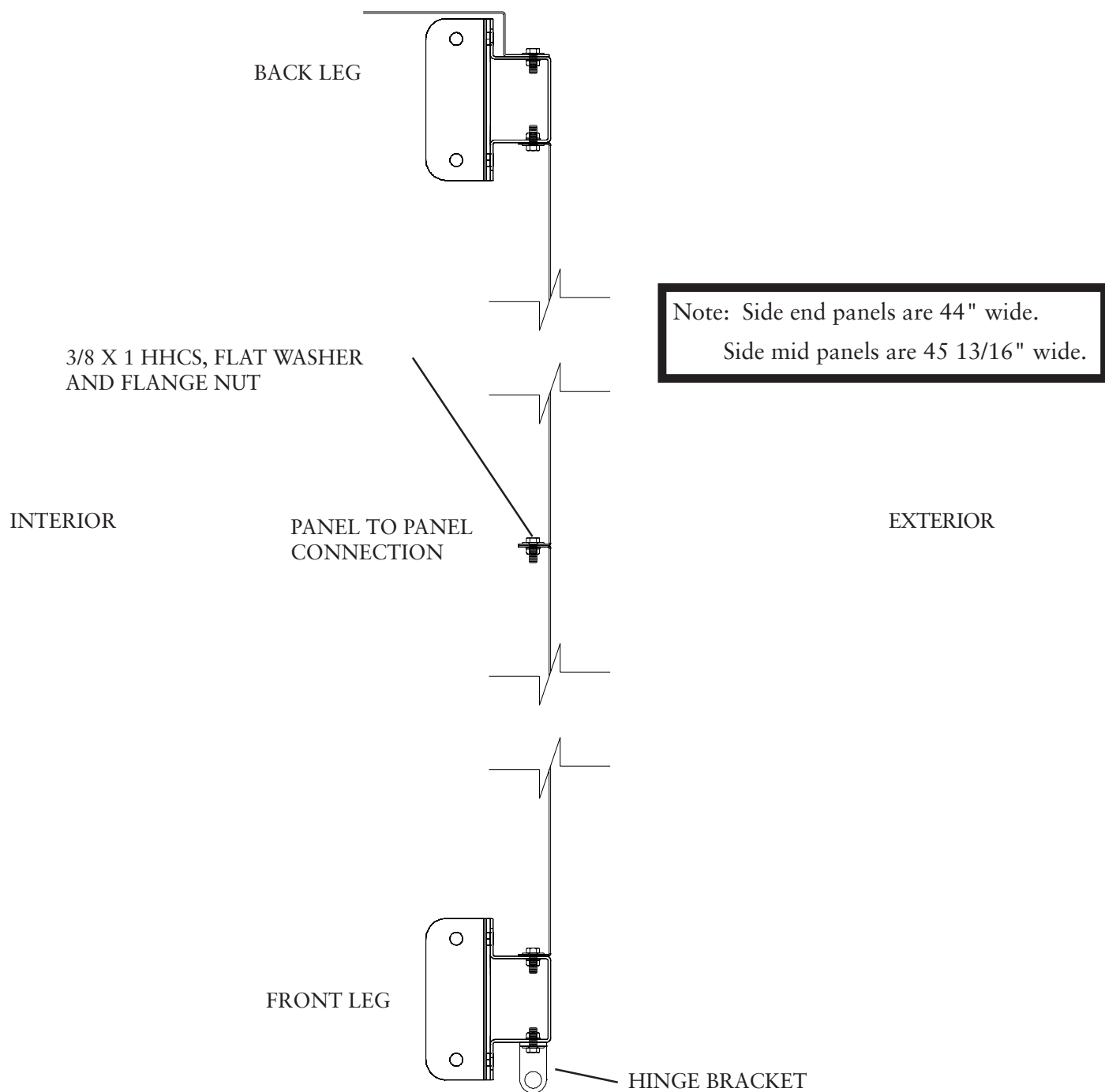

5) Anchoring

At this point all structural bolts and panel bolts are tightened. The bin is squared up and level as well as in the proper location. Use 1/2" wedge anchors provided by others to secure binhouse to concrete slab.

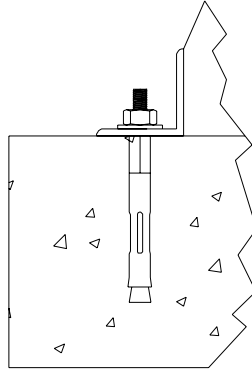

TYPICAL WEDGE ANCHOR  
INSTALLATION

6) Attaching doors

The binhouse doors ship fully assembled and need only be attached to the hinge bracket with the provided 3/4 NC x 5" hchs, flat washers and nylock nuts. The doors are heavy and need to be securely supported until all hinge bolts are installed and tightened. Swing doors to ensure that they travel freely and without obstruction. The doors swing approximately 110° to the open position. Close doors and slide latch to hold doors closed. Make sure the doors are parallel to the lip on the top end plate. Lower the cane bolts to the slab and mark position. Lift cane bolts and open doors to full open position, lower cane bolt and mark position. Drill holes in slab to accept cane bolts.

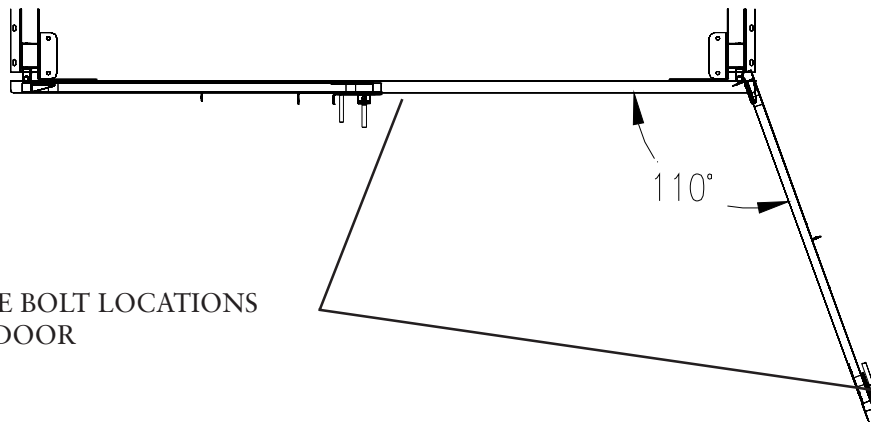

MARK CANE BOLT LOCATIONS  
FOR EACH DOOR

## 7) Flashings

Lower side wall, lower back wall and upper back wall flashings are field installed. Upper side wall flashing is factory installed on the roof assembly. In order to achieve a flat straight wall a chalk line should be used to help locate the lower flashings on the slab. Attach the flashings to the slab first using anchors provided by others then place a bead of silicone on the wall side of the flashing and attach the flashing to the wall panels using provided self drilling sheetmetal screws. This will pull the panels into a straight position. Upper back flashing attaches to roof assembly and then is fastened to back panels with self drilling sheetmetal screws.

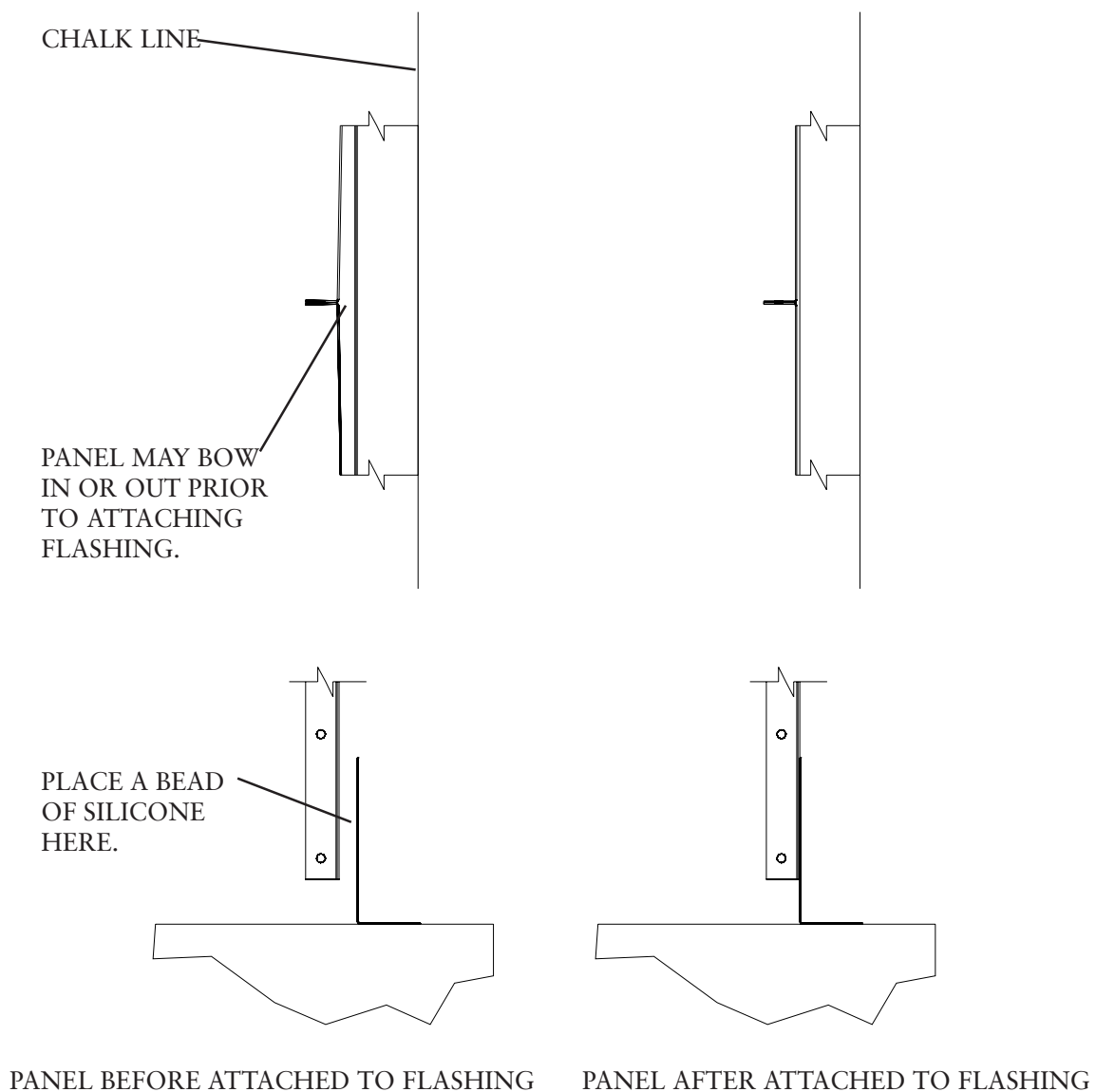

8) Leveling auger installation

Mount the back u-bracket, bearing plate and stiffeners to the back center panel and roof end plate.

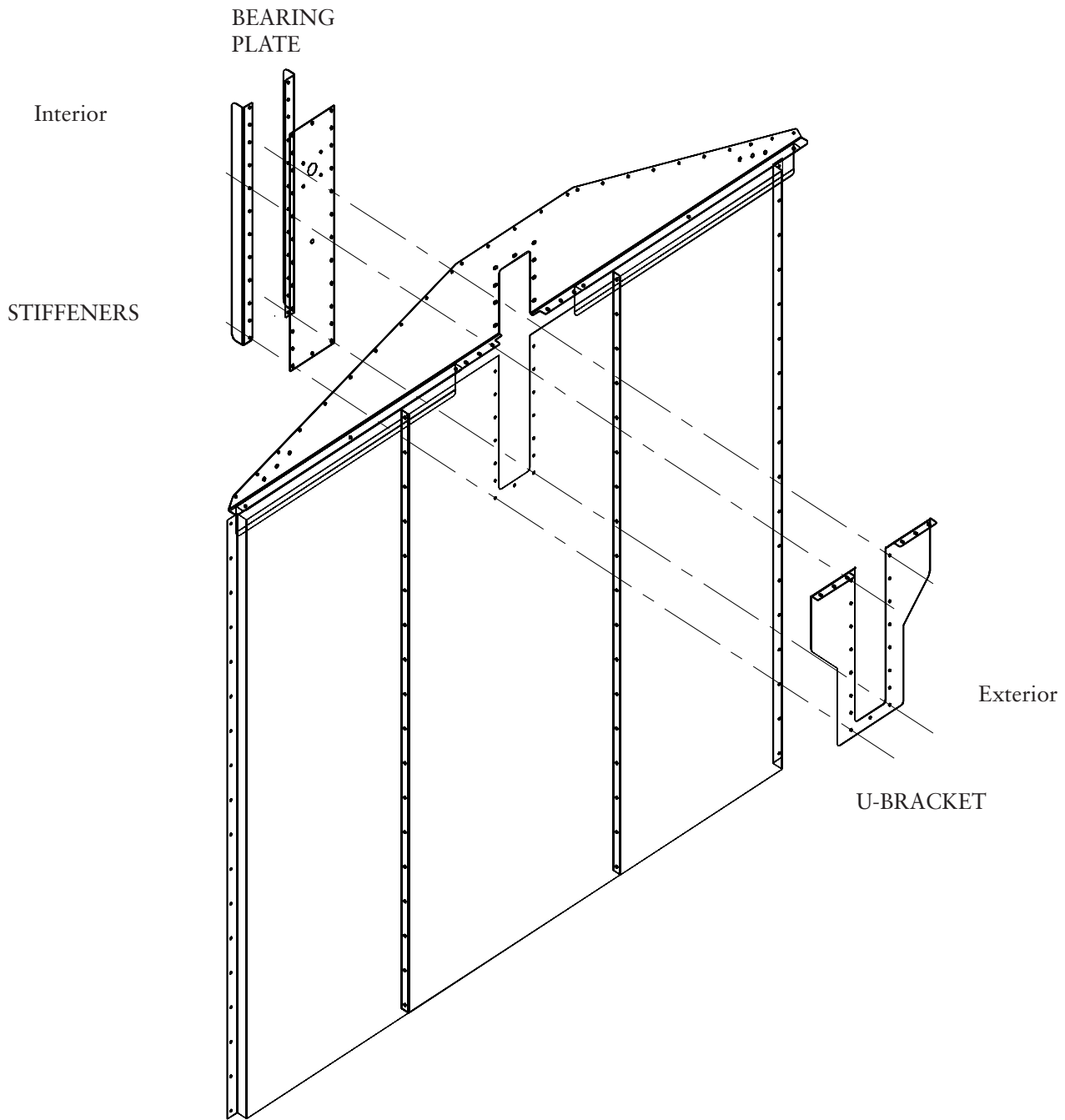

Mount the hanger bearing support bracket to roof ribs as shown below. Slide thrust washers on to drive shaft. The thrust washer set consists of two outer steel washers and one inner bronze washer. Insert the auger with the keyed drive shaft through the bearing mount plate in the back wall. Slide hanger bearing onto coupling shaft on other end of auger. Attach hanger bearing to hanger bearing support bracket. Slide the four bolt flange bearing over the drive shaft and bolt to bearing end plate. The first auger should now be able to turn in its bearings.

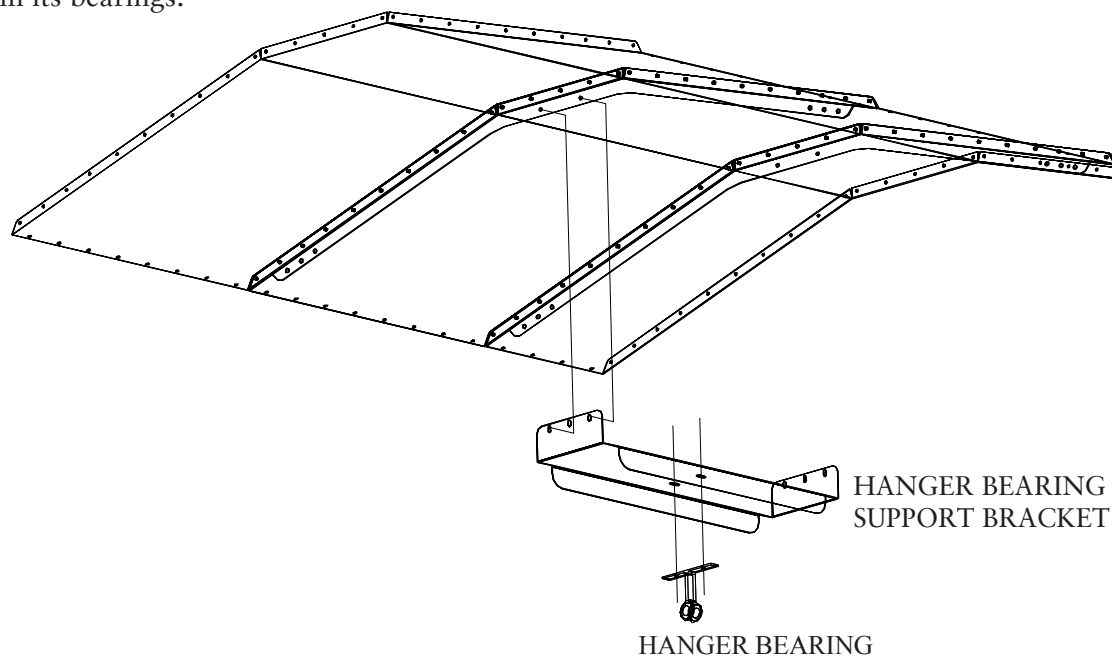

Mount the tail bearing mount angles to the tail bearing mount as shown below. Insert the auger with the short tail shaft through the tail bearing mount. Slide the four bolt flange bearing over the tail shaft and bolt to bearing tail bearing end mount. Lift the auger and bearing plate up and slide onto coupling shaft. Bolt tail bearing angles to roof truss. Install coupling bolts into coupling shaft. The entire auger should now be able to turn in its bearings.

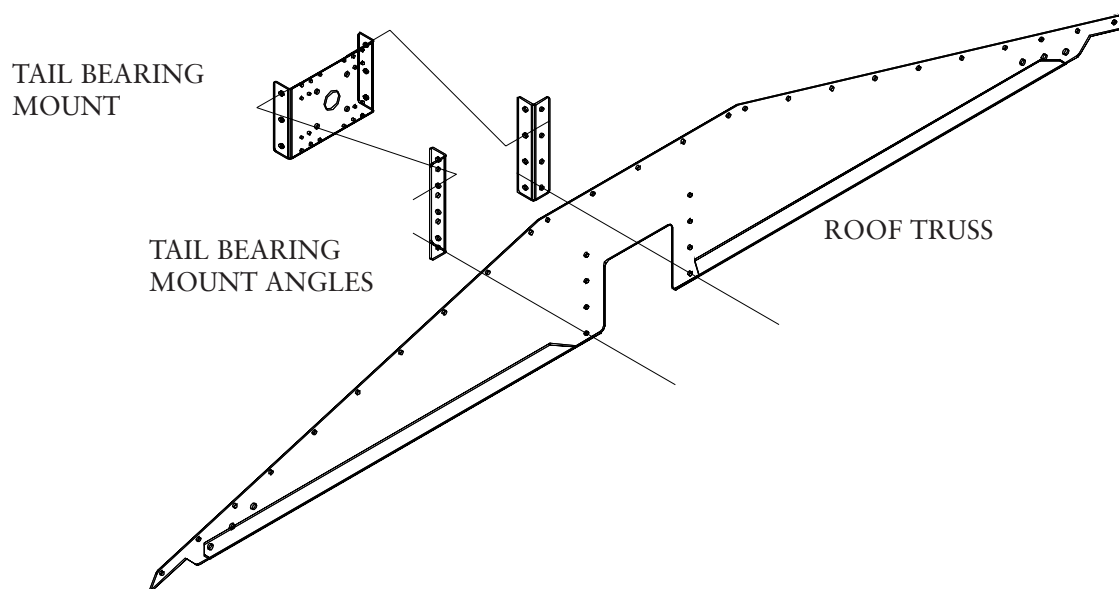

Attach torque arm bracket to gearbox if not factory installed. Bracket should be mounted to bottom side of gearbox. The bottom of the gearbox is the side closest to the drive shaft bore. Slide gearmotor assembly onto drive shaft making sure to align keyway on drive shaft and gearbox. Insert key and tighten set screws. Insert the 5/8 bolt through the torque arm bracket. Thread flange nut onto bolt with flange end facing away from bolt head. Thread nut on all the way to top of the threads. Insert threaded end through end bearing mount plate and install 5/8 flat washer and nylock nut. Tighten nylock nut until flange nut seats against bearing end plate. This bolt should be mounted rigidly to the bearing mount plate **not** to the torque arm bracket. The gearbox floats with the drive shaft and this bolt keeps the gearbox from winding around the shaft yet allows movement due to variances in the auger. If gearbox breather has pin inserted remove prior to running gearbox or seal will get damaged causing gearbox to leak and voiding all warranty on the gearbox.

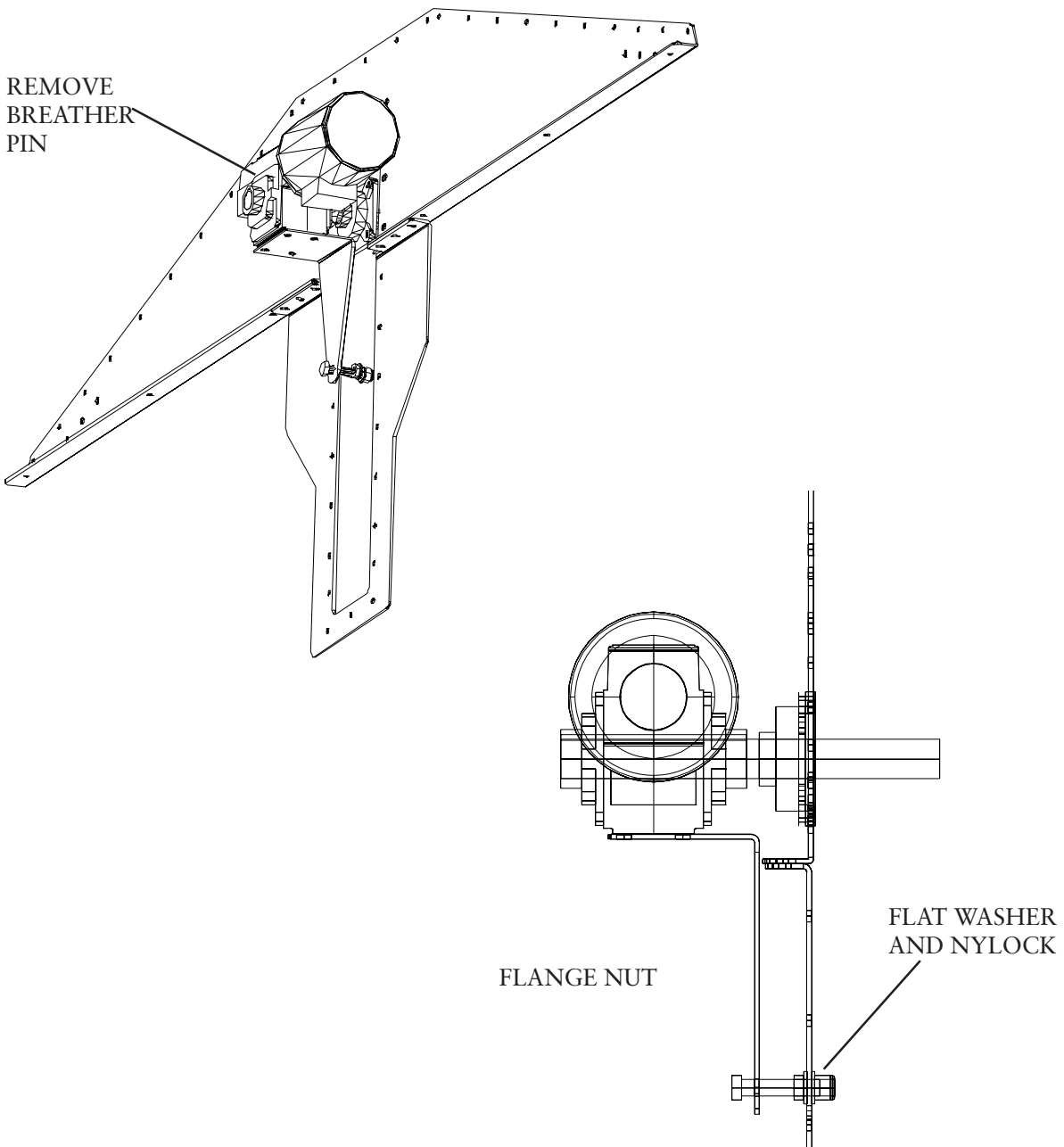

## 9) Infeed chute

The infeed chute is sent long from the factory and is to be field cut. Measure the distance between the airlock flange and the top of the bin cover roof. Cut the spouting to this length minus 1/2" (the 1/2" gap is covered by the flashing). Cut the opening in the roof panel to the I.D. of the airlock flange plus 1/2", this opening is centered with the airlock. Slide the discharge spout into the opening with flange on top, bolt to airlock. Apply silicone to flashing and use self drilling screws to attach the flashing to the airlock spout and the top of the bin cover. Use flashing on all four sides of the spouting.

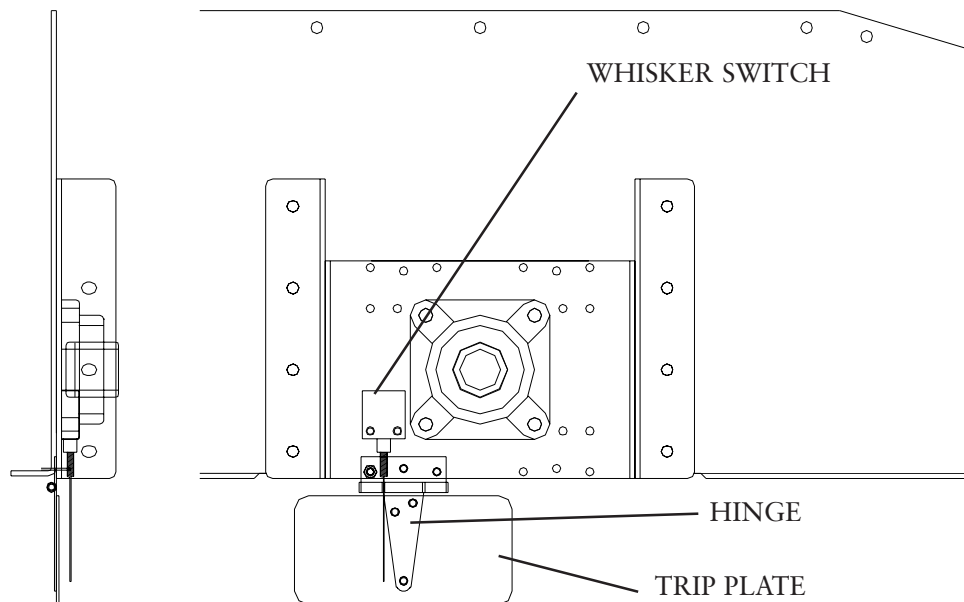
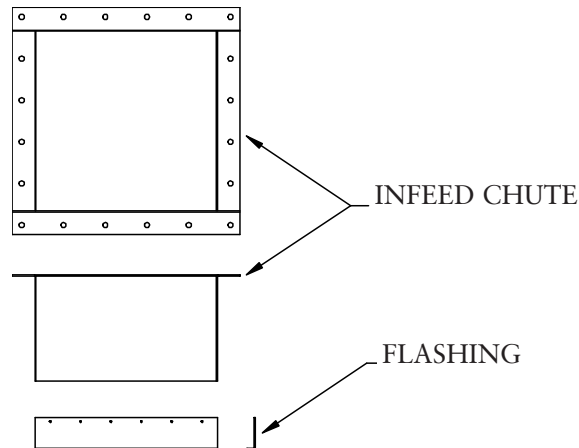

## 10) Optional equipment

It is recommended that some form of guide rails or stops be used in guiding the dumpster into the bin cover. These guides are available from Donaldson Torit.

A high level switch is available that mounts to the end bearing bracket that allows for alarm or shut down in the event the bin becomes full. Contact Donaldson Torit for details.

## OPERATION

### Pre-Start-Up Checklist

- All bolt connections tightened.
- All electrical connections made.
- Reducer oil level topped off and vent in place and operational.
- Filter, fan and rotary airlock operational.
- No obstructions between airlock and cover opening.
- Dumpster bin is in place.
- Auger rotation is correct to take material away from the back.

### Start up Sequence - Typical

- 1) Start rotary airlock and bin cover auger.
- 2) Start filter timer/sequencer (if applicable).
- 3) Start blower (if applicable).
- 4) Start process equipment.

### Shut down Sequence - Typical

- 1) Stop process equipment. Allow filter to continue operating for 10-15 minutes (if applicable).
- 2) Stop blower (if applicable). Allow airlock, auger and timer to continue running for 10-15 minutes.
- 3) Stop timer (if applicable), airlock and auger.

When dumpster is full, it may be necessary to level out the pile before removing the dumpster. The bin cover should be monitored daily (or more often depending on the amount of material being processed) to insure material does not run off the front of the bin.

## MAINTENANCE

Prior to shipping all LMC auger drives are filled with the proper amount of oil in the reducer. During transit some oil may leak out through the vent cap. Check oil level in reducer and top off with the appropriate oil for your conditions. See table below. If vent plug is not present one must be installed prior to placing unit into service. Failure to provide proper venting will cause seal failure.

AIR TEMP. °F	AGMA NO.
15-60	7C
50-125	8C

Change oil in reducer after one week of service then twice a year after.

Bearings are filled with grease at the factory and require only normal periodic re-lubrication with a good quality No. 2 grease.



PHOTOCOPY THIS FORM

# PARTS ORDER FORM

**MAIL TO:** Donaldson Torit  
Customer Service  
5300 Claus Road  
Riverbank, CA 95367

OR

**FAX TO:** (209)-869-0258

CUSTOMER NAME: \_\_\_\_\_

SHIPPING ADDRESS \_\_\_\_\_ BILLING ADDRESS: \_\_\_\_\_

MODEL NO. \_\_\_\_\_

SERIAL NO. \_\_\_\_\_

DESCRIPTION	QTY	
<input type="checkbox"/> 1HP C-FACE MOTOR	<input type="checkbox"/>	ADDITIONAL PARTS MAY BE NECESSARY TO RAISE OR LOWER AUGER HEIGHT. CONSULT FACTORY FOR PARTS NEEDED.
<input type="checkbox"/> GEARBOX	<input type="checkbox"/>	
<input type="checkbox"/> 4-BOLT FLANGE BEARING	<input type="checkbox"/>	
<input type="checkbox"/> HANGER BEARING	<input type="checkbox"/>	
<input type="checkbox"/> HELICOID SCREW CONVEYOR 9-10" LONG.	<input type="checkbox"/>	
<input type="checkbox"/> THRUST WASHER SET	<input type="checkbox"/>	
<input type="checkbox"/> COUPLING BOLTS, 1/2 X 3	<input type="checkbox"/>	
<input type="checkbox"/> AUGER DRIVE SHAFT	<input type="checkbox"/>	
<input type="checkbox"/> AUGER COUPLING SHAFT	<input type="checkbox"/>	
<input type="checkbox"/> AUGER TAIL SHAFT	<input type="checkbox"/>	
<input type="checkbox"/> DOOR SLIDE ACTION BOLT	<input type="checkbox"/>	
<input type="checkbox"/> DOOR CANE BOLT	<input type="checkbox"/>	
<input type="checkbox"/> DUMPSTER GUIDE RAILS	<input type="checkbox"/>	
<input type="checkbox"/> HIGH LEVEL SWITCH KIT	<input type="checkbox"/>	





## The Donaldson Torit Warranty

Donaldson warrants to the original purchaser that the products will be free from defects in materials and workmanship for one (1) years from the date of shipment, if properly installed, maintained and operated under normal conditions. Donaldson does not warrant against damages due to corrosion, abrasion, normal wear and tear, product modification, or product misapplication. Donaldson also makes no warranty whatsoever as to any goods manufactured or supplied by others including electric motors, fans and control components. After Donaldson has been given adequate opportunity to remedy any defects in material or workmanship, Donaldson retains the sole option to accept return of the goods, with freight paid by the purchaser, and to refund the purchase price for the goods after confirming the goods are returned undamaged and in usable condition. Such a refund will be in the full extent of Donaldson's liability. Donaldson shall not be liable for any other costs, expenses or damages whether direct, indirect, special, incidental, consequential or otherwise. The terms of this warranty may be modified only by a special warranty document signed by a Director, General Manager or Vice President of Donaldson. Failure to use genuine Donaldson replacement parts may void this warranty. **THERE EXIST NO OTHER REPRESENTATIONS, WARRANTIES OR GUARANTEES EXCEPT AS STATED IN THIS PARAGRAPH AND ALL OTHER WARRANTIES INCLUDING MERCHANTABILITY AND FITNESS FOR A PARTICULAR PURPOSE, WHETHER EXPRESS OR IMPLIED ARE HEREBY EXPRESSLY EXCLUDED AND DISCLAIMED.**

## Parts and Service

For genuine Donaldson Torit replacement filters  
and parts, call the Parts Express Line

**800-562-0072**

**[www.donaldsontorit.com/lmcwest](http://www.donaldsontorit.com/lmcwest)**

For faster service, have unit's model and serial number,  
part number, description, and quantity available.



**Donaldson**  
*Filtration Solutions*

Donaldson Company, Inc.  
Industrial Air Filtration  
P.O. Box 1299  
Minneapolis, MN 55440-1299  
[donaldsontorit@donaldson.com](mailto:donaldsontorit@donaldson.com)

Donaldson Company, Inc. is the leading designer and manufacturer of dust, mist, and fume collection equipment used to control industrial-air pollutants. Our equipment is designed to help reduce occupational hazards, lengthen machine life, reduce in-plant maintenance requirements, and improve product quality.