



(12) **EUROPEAN PATENT APPLICATION**

(88) Date of publication A3:
03.05.2000 Bulletin 2000/18

(51) Int Cl.7: **B65D 33/25, B65D 75/58**

(43) Date of publication A2:
29.09.1999 Bulletin 1999/39

(21) Application number: **99301851.4**

(22) Date of filing: **11.03.1999**

(84) Designated Contracting States:
**AT BE CH CY DE DK ES FI FR GB GR IE IT LI LU
MC NL PT SE**
Designated Extension States:
AL LT LV MK RO SI

(72) Inventor: **Tomic, Mladomir
Appleton, Wisconsin 54915 (US)**

(74) Representative: **Belcher, Simon James
Urquhart-Dykes & Lord
Tower House
Merrion Way
Leeds LS2 8PA (GB)**

(30) Priority: **13.03.1998 US 41603**

(71) Applicant: **REYNOLDS METALS COMPANY
Richmond, Virginia 23230-1701 (US)**

(54) **Zip lock bag closure with peelable seal**

(57) A peelable seal (40) includes four layers. The first layer includes first and second alternating ribs (37,38). The first ribs comprise a first material, and the second ribs comprise a second material. The first material bonds well with the closure profiles (28,30). The second material bonds well with the third and fourth layers (33,35). The first material does not bond well with

the second material. Thus, the bond strength is lower between the first and second ribs and between the third and fourth ribs than between the first and third ribs and the closure profiles and between the second and fourth ribs and the third and fourth layers. In this process, the strength of the peelable seal is controlled during the extrusion process rather than being subjected to the variations in the manufacturing process.

FIG. 3

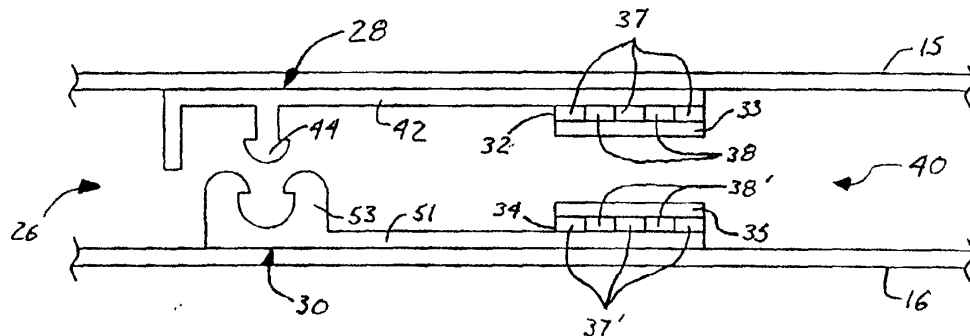



European Patent
Office

EUROPEAN SEARCH REPORT

Application Number
EP 99 30 1851

DOCUMENTS CONSIDERED TO BE RELEVANT			CLASSIFICATION OF THE APPLICATION (Int.Cl.6)
Category	Citation of document with indication, where appropriate, of relevant passages	Relevant to claim	
A	EP 0 648 687 A (IDEMITSU PETROCHEMICAL CO) 19 April 1995 (1995-04-19) * page 4, line 21 - line 38; figure 4 * ---	1-5,7,8,10	B65D33/25 B65D75/58
A	US 5 647 671 A (MAY TIMOTHY J) 15 July 1997 (1997-07-15) * column 9, line 8 - column 10, line 57 * * column 12, line 56 - column 13, line 6; figures 11,12 * ---	1,6,8-10	
A	US 3 217 871 A (LEE ROBERT L) 16 November 1965 (1965-11-16) * column 3, line 74 - column 4, line 2; figure 6 * ---	1,8	
A	US 5 107 658 A (HUSTAD GERALD O ET AL) 28 April 1992 (1992-04-28) * column 5, line 65 - column 6, line 28; figure 6A * -----	1	
The present search report has been drawn up for all claims			TECHNICAL FIELDS SEARCHED (Int.Cl.6)
			B65D
Place of search	Date of completion of the search	Examiner	
THE HAGUE	8 March 2000	Sundell, O	
CATEGORY OF CITED DOCUMENTS		T : theory or principle underlying the invention E : earlier patent document, but published on, or after the filing date D : document cited in the application L : document cited for other reasons & : member of the same patent family, corresponding document	
X : particularly relevant if taken alone Y : particularly relevant if combined with another document of the same category A : technological background O : non-written disclosure P : intermediate document			

EPO FORM 1503 03/82 (P/AC01)

**ANNEX TO THE EUROPEAN SEARCH REPORT
ON EUROPEAN PATENT APPLICATION NO.**

EP 99 30 1851

This annex lists the patent family members relating to the patent documents cited in the above-mentioned European search report. The members are as contained in the European Patent Office EDP file on
The European Patent Office is in no way liable for these particulars which are merely given for the purpose of information.

08-03-2000

Patent document cited in search report	Publication date	Patent family member(s)	Publication date
EP 0648687 A	19-04-1995	JP 7112746 A	02-05-1995
		AU 663447 B	05-10-1995
		AU 7587294 A	08-06-1995
		DE 69407531 D	05-02-1998
		DE 69407531 T	23-07-1998
		US 5538345 A	23-07-1996
US 5647671 A	15-07-1997	US 5470156 A	28-11-1995
		US 5725312 A	10-03-1998
		US 5887980 A	30-03-1999
		US 5893645 A	13-04-1999
		US 5904425 A	18-05-1999
		US 5509735 A	23-04-1996
		US 5489252 A	06-02-1996
		US 5551127 A	03-09-1996
		US 3217871 A	16-11-1965
US 5107658 A	28-04-1992	US 4823961 A	25-04-1989
		US 5050736 A	24-09-1991
		US 4782951 A	08-11-1989
		US 5014856 A	14-05-1991
		US 5005707 A	09-04-1991