

# Digital Circuits and Computer Design

Notes #6

"Sequential Circuits: *Registers & RAM*"

Spring Quarter 2010

Avinash Kodi

Acknowledgement: Dr. Maarten Uijt de Haag

## Sequential Circuits

- This section discusses two sequential circuit components that form the basis for a computer:
  - Registers (temporary storage)
  - Memory (storage of data & instructions)

These memory components are the basic information storage elements of a computer !!

# Combinational & Sequential Microcontroller Example

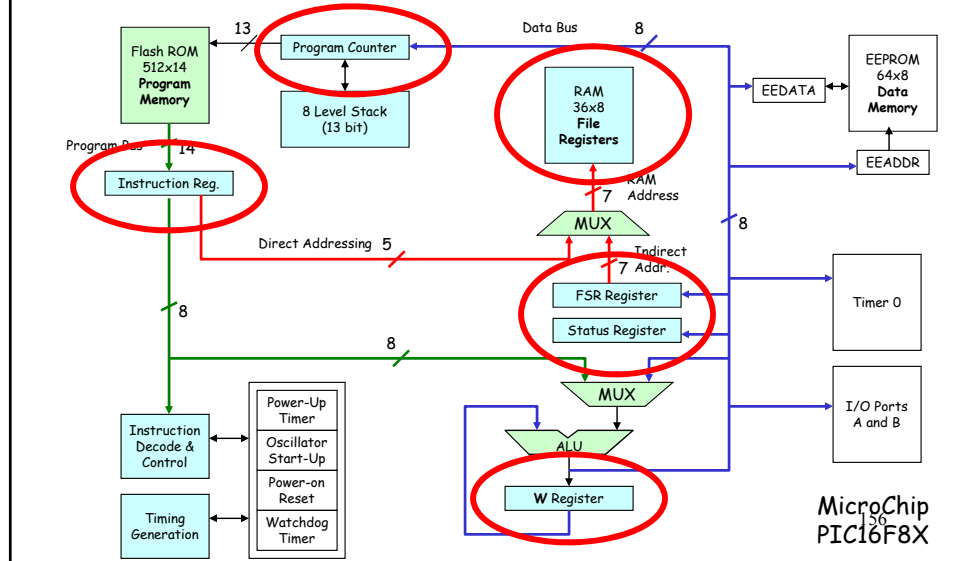

# Sequential Circuits Register Functions

## Register:

A physical location in a processor that can contain a binary number. This location is used to store information temporarily. The register size is expressed in bits.

## Functions:

- Write data to the register/ Parallel Load,
- Hold data (no change),
- Shift contents (logical, arithmetic, rotate),
- Clear contents.

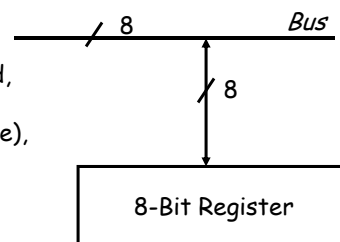

# Registers

## Parallel Load : 1-Bit Register 2-Busses

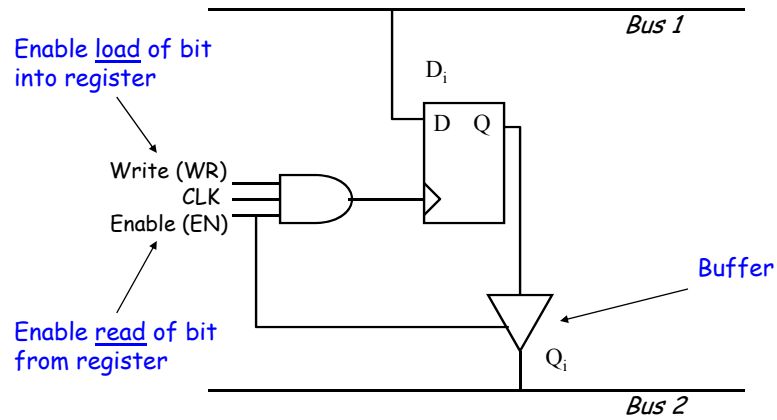

Note: One can clearly see the basic ingredients of a sequential circuit; the combinational logic and the memory element 158

# Registers

## Parallel Load : 4-Bit Register

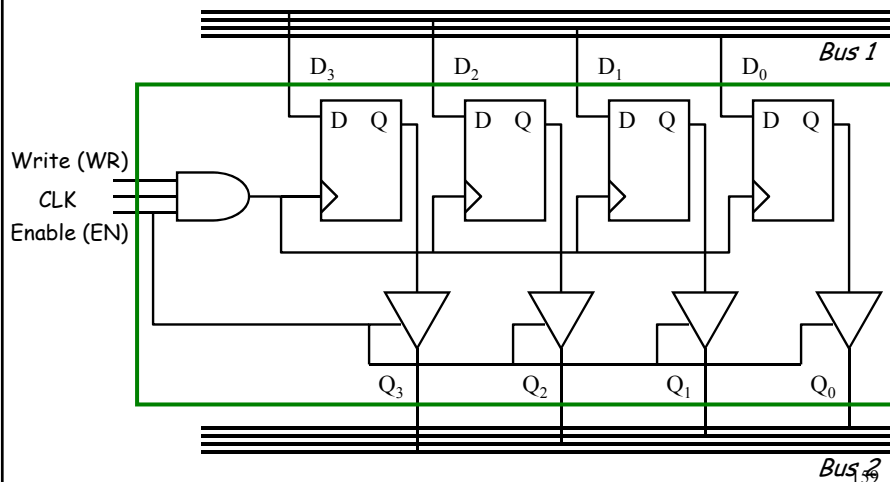

# Registers

## Tri-State Buffer

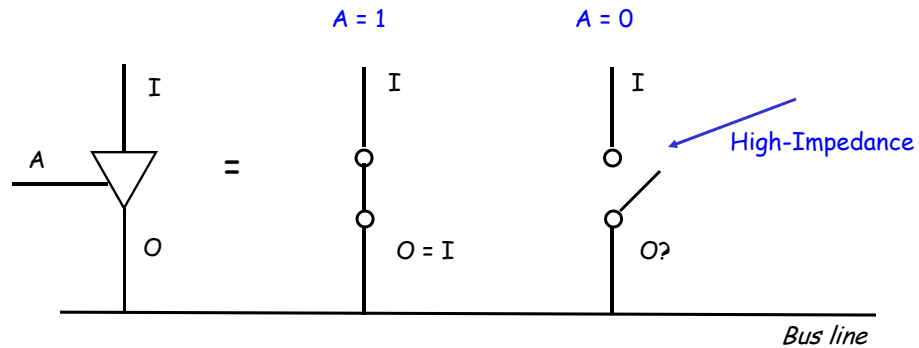

160

# Registers

## Parallel Load : 4-Bit Register, 2-Busses

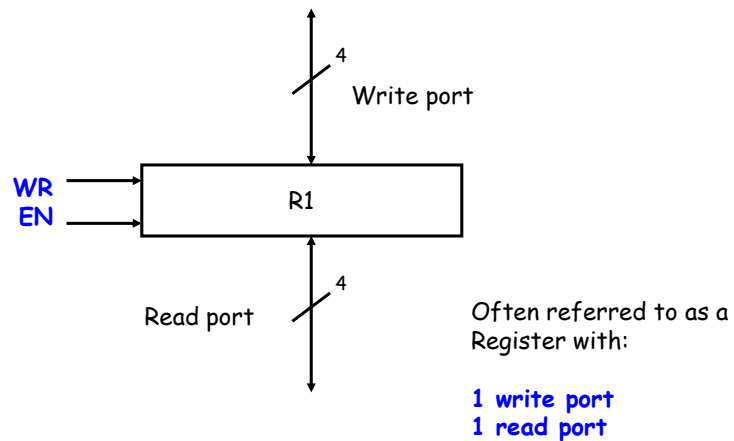

161

# Registers

## *Parallel Load : 1-Bit Register, 1-Bus*

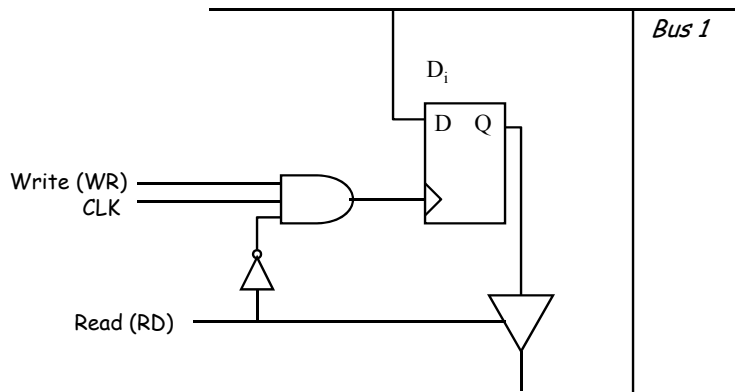

162

Or

## *Parallel Load : 1-Bit Register, 1-Bus*

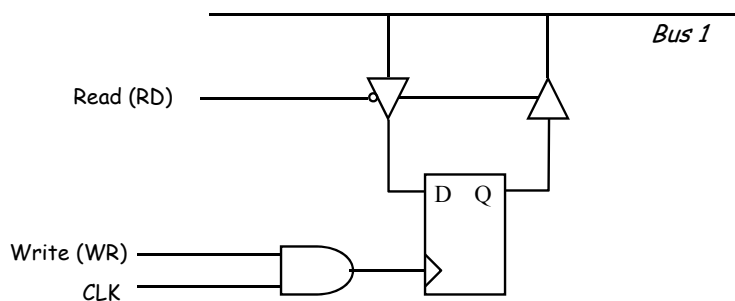

163

# Registers

*Parallel Load : 1-Bit Register, 1-Bus*

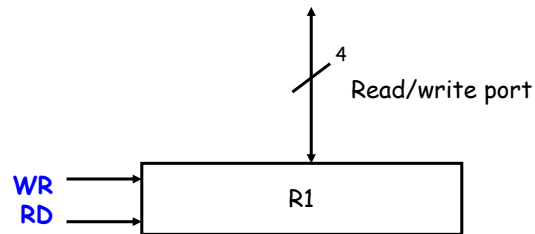

164

# Hardware: Memory

Parts of the microcomputer where information is stored

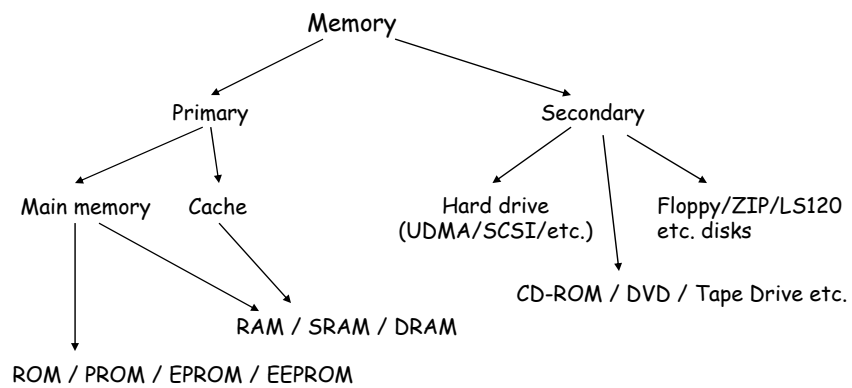

165

# Semiconductor Memory Devices

## *Types*

Memory Type	Category	Erasure	Write mechanism	Refresh mechanism	Volatility
Random-Access Memory (RAM):	Read-write Memory	Electrically, Byte level	Electrically	Depends	Volatile
Static RAM (SRAM)				Not necessary	
Dynamic RAM (DRAM)				Necessary	
Read-only Memory (ROM)	Read-only Memory	Not Possible	Masks		
Programmable ROM (PROM)					
Erasable PROM (EPROM)	Read-mostly Memory	UV Light, Chip level	Electrically	Not applicable	Non-volatile
Flash memory		Electrically, Block level			
Electrically EPROM (EEPROM)		Electrically, Byte level			

166

## Random Access Memory *(read/write volatile memory)*

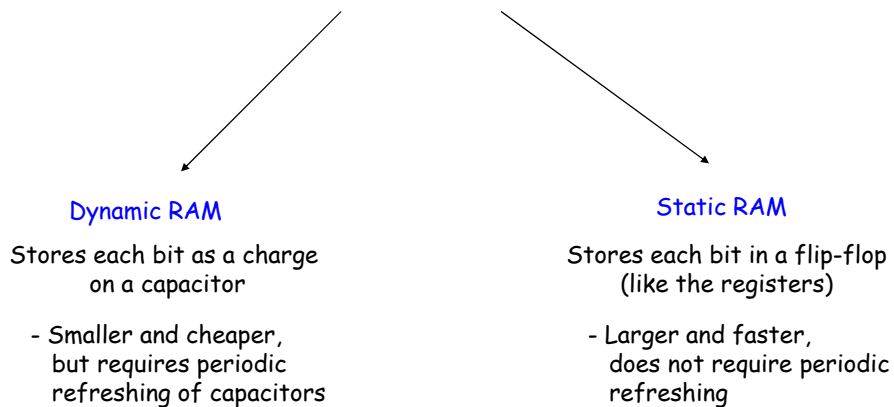

167

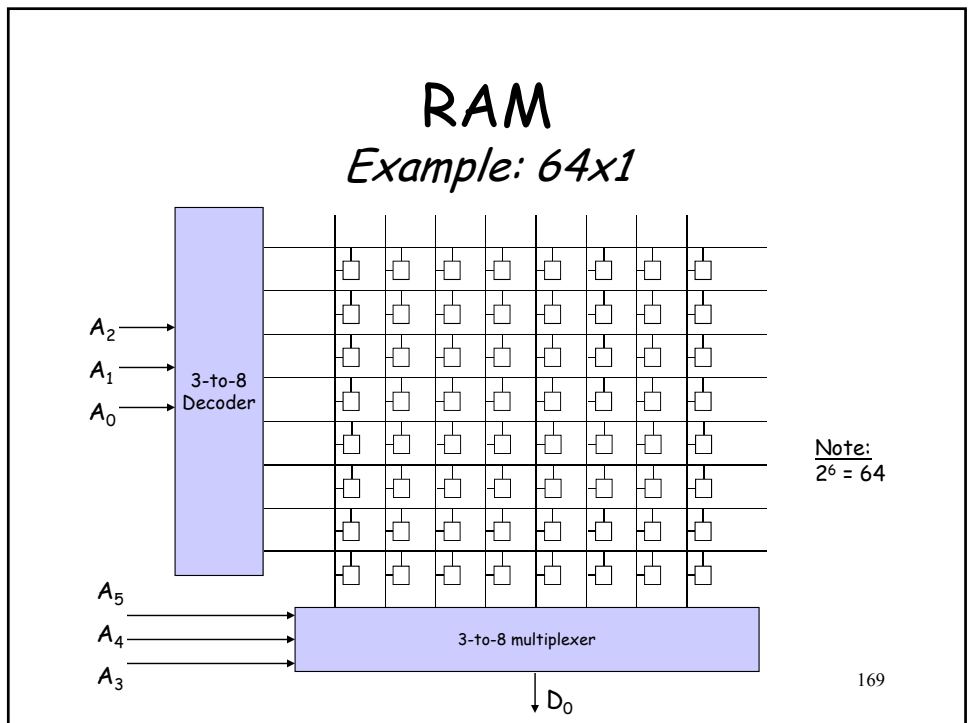
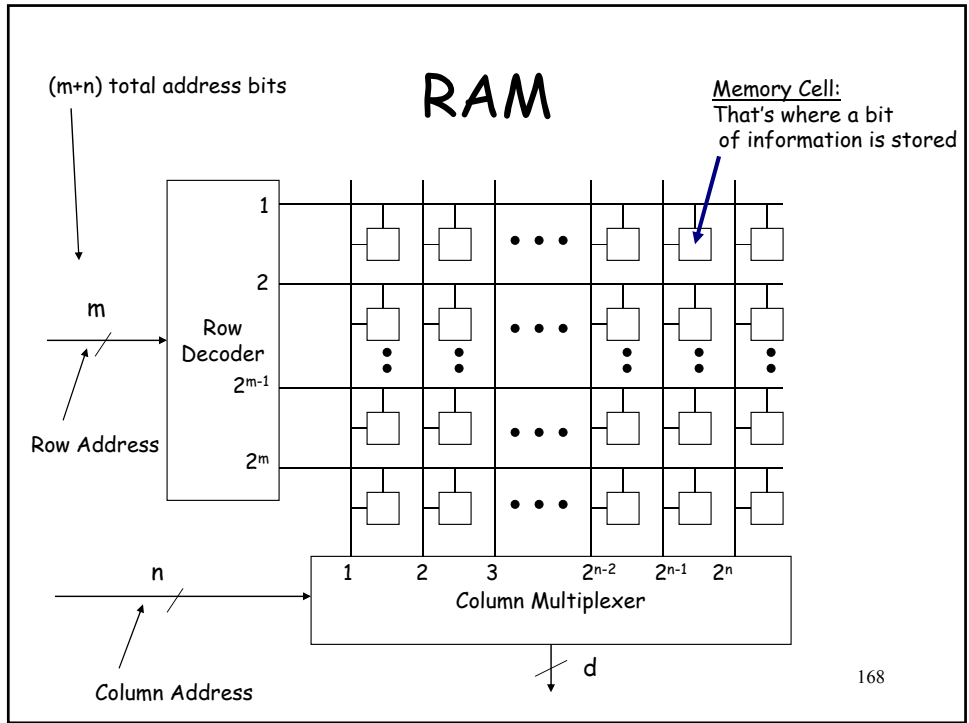



# Static RAM Memory Cell

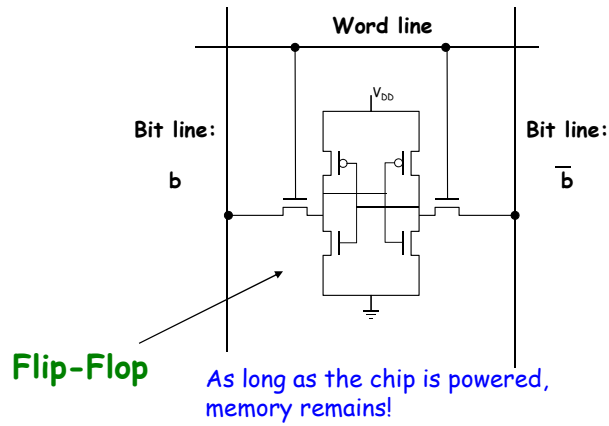

170

# Dynamic RAM Memory Cell

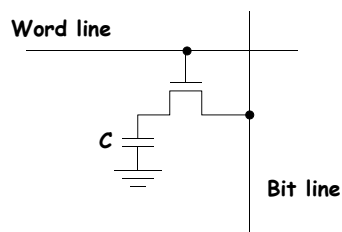

The capacitor requires a regular refreshing cycle b/c it will slowly discharge !

171