

MACKIE®

ONYX·800R

**PREMIUM EIGHT CHANNEL
MICROPHONE PREAMP**

w/192 kHz DIGITAL OUTPUT

OWNER'S MANUAL

ONYX
ONYX
ONYX
ONYX
ONYX
ONYX
ONYX
ONYX
ONYX

Important Safety Instructions

1. Read these instructions.
2. Keep these instructions.
3. Heed all warnings.
4. Follow all instructions.
5. Do not use this apparatus near water.
6. Clean only with dry cloth.
7. Do not block any ventilation openings. Install in accordance with the manufacturer's instructions.
8. Do not install near any heat sources such as radiators, heat registers, stoves, or other apparatus (including amplifiers) that produce heat.
9. Do not defeat the safety purpose of the polarized or grounding-type plug. A polarized plug has two blades with one wider than the other. A grounding-type plug has two blades and a third grounding prong. The wide blade or the third prong are provided for your safety. If the provided plug does not fit into your outlet, consult an electrician for replacement of the obsolete outlet.
10. Protect the power cord from being walked on or pinched particularly at plugs, convenience receptacles, and the point where they exit from the apparatus.
11. Only use attachments/accessories specified by the manufacturer.
12. Use only with a cart, stand, tripod, bracket, or table specified by the manufacturer, or sold with the apparatus. When a cart is used, use caution when moving the cart/apparatus combination to avoid injury from tip-over.
13. Unplug this apparatus during lightning storms or when unused for long periods of time.
14. Refer all servicing to qualified service personnel. Servicing is required when the apparatus has been damaged in any way, such as power-supply cord or plug is damaged, liquid has been spilled or objects have fallen into the apparatus, the apparatus has been exposed to rain or moisture, does not operate normally, or has been dropped.
15. This apparatus has been designed with Class-I construction and must be connected to a mains socket outlet with a protective earthing connection (the third grounding prong).
16. This apparatus has been equipped with a single-pole, rocker-style AC mains power switch. This switch is located on the front panel and should remain readily accessible to the user.
17. This apparatus does not exceed the Class A/Class B (whichever is applicable) limits for radio noise emissions from digital apparatus as set out in the radio interference regulations of the Canadian Department of Communications.

ATTENTION — *Le présent appareil numérique n'émet pas de bruits radioélectriques dépassant les limites applicables aux appareils numériques de class A/de class B (selon le cas) prescrites dans le règlement sur le brouillage radioélectrique édicté par les ministere des communications du Canada.*

18. Exposure to extremely high noise levels may cause permanent hearing loss. Individuals vary considerably in susceptibility to noise-induced hearing loss, but nearly everyone will lose some hearing if exposed to sufficiently intense noise for a period of time. The U.S. Government's Occupational Safety and Health Administration (OSHA) has specified the permissible noise level exposures shown in the following chart.

According to OSHA, any exposure in excess of these permissible limits could result in some hearing loss. To ensure against potentially dangerous exposure to high sound pressure levels, it is recommended that all persons exposed to equipment capable of producing high sound pressure levels use hearing protectors while the equipment is in operation. Ear plugs or protectors in the ear canals or over the ears must be worn when operating the equipment in order to prevent permanent hearing loss if exposure is in excess of the limits set forth here.

| Duration Per Day In Hours | Sound Level dBA, Slow Response | Typical Example |
|------------------------------|-----------------------------------|--|
| 8 | 90 | Duo in small club |
| 6 | 92 | |
| 4 | 95 | Subway Train |
| 3 | 97 | |
| 2 | 100 | Very loud classical music |
| 1.5 | 102 | |
| 1 | 105 | Tami screaming at Adrian about deadlines |
| 0.5 | 110 | |
| 0.25 or less | 115 | Loudest parts at a rock concert |

PORTABLE CART WARNING



Carts and stands - The Component should be used only with a cart or stand that is recommended by the manufacturer. A Component and cart combination should be moved with care. Quick stops, excessive force, and uneven surfaces may cause the Component and cart combination to overturn.

CAUTION AVIS

RISK OF ELECTRIC SHOCK
DO NOT OPEN

RISQUE DE CHOC ELECTRIQUE
NE PAS OUVRIR

CAUTION: TO REDUCE THE RISK OF ELECTRIC SHOCK
DO NOT REMOVE COVER (OR BACK)
NO USER-SERVICEABLE PARTS INSIDE
REFER SERVICING TO QUALIFIED PERSONNEL

ATTENTION: POUR EVITER LES RISQUES DE CHOC ELECTRIQUE, NE PAS ENLEVER LE COUVERCLE. AUCUN ENTRETIEN DE PIECES INTERIEURES PAR L'USAGER. CONFIER L'ENTRETIEN AU PERSONNEL QUALIFIE.

AVIS: POUR EVITER LES RISQUES D'INCENDIE OU D'ELECTROCUTION, N'EXPOSEZ PAS CET ARTICLE A LA PLUIE OU A L'HUMIDITE

The lightning flash with arrowhead symbol within an equilateral triangle is intended to alert the user to the presence of uninsulated "dangerous voltage" within the product's enclosure, that may be of sufficient magnitude to constitute a risk of electric shock to persons.

Le symbole clair avec point de flèche l'intérieur d'un triangle équilatéral est utilisé pour alerter l'utilisateur de la présence d'un risque de choc électrique.

The exclamation point within an equilateral triangle is intended to alert the user of the presence of important operating and maintenance (servicing) instructions in the literature accompanying the appliance.

Le point d'exclamation l'intérieur d'un triangle équilatéral est employé pour alerter les utilisateurs de la présence d'instructions importantes pour le fonctionnement et l'entretien (service) dans le livre d'instruction accompagnant l'appareil.

WARNING — To reduce the risk of fire or electric shock, do not expose this apparatus to rain or moisture.

Table of Contents

| | |
|--|-----------|
| Introduction | 4 |
| Getting Started | 5 |
| Zero the Controls | 5 |
| Connections | 5 |
| Set the Levels | 5 |
| Start Recording..... | 5 |
| Hookup Diagrams | 6 |
| Onyx 800R Features | 10 |
| Front Panel | 10 |
| Rear Panel..... | 12 |
| Appendix A: Service Information | 16 |
| Warranty Service..... | 16 |
| Troubleshooting | 16 |
| Repair | 17 |
| Appendix B: Connections | 18 |
| Appendix C: Technical Info | 20 |
| Onyx 800R Specifications | 20 |
| Onyx 800R Block Diagram | 22 |
| Onyx 800R Limited Warranty | 23 |

Please write your serial number here for future reference (i.e., insurance claims, tech support, return authorization, etc.)

Purchased at:

Date of purchase:

Don't forget to visit our website at www.mackie.com for more information about this and other Mackie products.



Introduction

Thank you for choosing a Mackie Onyx 800R eight-channel professional microphone preamplifier. The Onyx Series of mixers and microphone preamps are designed for the digital era and offer the newest features and latest technologies for live sound reinforcement and analog or digital studio recording in a durable, road-worthy package.

The Onyx 800R is equipped with eight of our new premium precision-engineered studio-grade Onyx mic preamps. Mackie is renowned for the high-quality mic preamps used in our mixers, and the Onyx mic pre's are better than ever, with specifications rivaling other stand-alone mic preamplifiers at twice the price.

The Onyx 800R is designed to be a transparent audio interface for direct tracking to MDM, HDR, or DAW recording applications. Its selection of analog and digital output options provides the flexibility to connect in almost any application.

Channels 1 and 2 feature an impedance select switch, which lets you fine tune the mic pre for vintage tube and ribbon microphones. Channels 1 and 2 also provide the option of engaging a Mid/Side Decoder for M-S stereo mic'ing. Adjusting the balance between channels 1 and 2 with their gain controls provides an effective way to vary the width of the stereo image.

Channels 7 and 8 feature high-impedance instrument inputs so you can connect an acoustic, electric, or bass guitar directly to the mic preamp, eliminating the need for an external direct box.

Each channel has a mic/line switch, a polarity reverse switch, individual phantom power switch, low-cut filter switch, and a gain control.

A sample rate selector allows you to choose 32, 44.1, 48, 88.2, 96, 176.4, or 192 kHz sample rates, or to use an external clock connected to the external word clock input connector on the rear panel. You can also select between 24-bit or 16-bit dithered word lengths at the digital outputs.

The rear panel provides individual XLR balanced mic input connectors for each channel, and balanced line inputs on a DB25 connector. Analog balanced line outputs are also provided on a DB25 connector. Digital outputs are provided on two optical Toslink connectors using the ADAT lightpipe digital audio format. AES/EBU or S/PDIF formats are available on a DB25 connector, with selection buttons for impedance, pro or consumer status bits, and single-wire (two-channel) or dual-wire (single-channel) operation.

HOW TO USE THIS MANUAL

We know that many of you can't wait to get your new microphone preamplifier hooked up, and you're probably not going to read the manual first (sigh!). So the first section after this introduction is a Quick-Start Guide called "Getting Started" to help you get the Onyx 800R set up fast so you can start using it right away. Right after that are the ever popular hook-up diagrams that show typical setups for live sound and recording.

Then, when you have time, read the Features Description section. This describes every knob, button, and connection point on the Onyx 800R.

Throughout this section you'll find illustrations with each feature numbered. If you want to know more about a feature, simply locate it on the appropriate illustration, notice the number attached to it, and find that number in the nearby paragraphs.



This icon marks information that is critically important or unique to the Onyx 800R. For your own good, read them and remember them. They will be on the final test.



This icon leads you to in-depth explanations of features and practical tips. While not mandatory, they usually have some valuable nugget of information.

A PLUG FOR THE CONNECTOR SECTION

Appendix B is a section on connectors: XLR connectors, balanced connectors, unbalanced connectors, and the two types of DB25 connectors used on the Onyx 800R.

More resources on our website at www.mackie.com.

THE GLOSSARY: A Haven of Non-Techiness for the Neophyte

The "Glossary of Terms" is a fairly comprehensive dictionary of pro-audio terms. If terms like "clipping," "noise floor," or "unbalanced" leave you blank, refer to this glossary for a quick explanation.

ARCANE MYSTERIES ILLUMINATED

"Arcane Mysteries" discusses some of the down 'n' dirty practical realities of microphones, fixed installations, grounding, and balanced versus unbalanced lines. It's a goldmine for the neophyte, and even the seasoned pro might learn a thing or two.

Getting Started

READ THIS PAGE!!

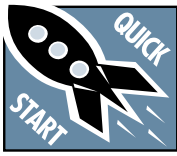

Even if you're one of those people who never reads manuals, all we ask is that you read this page now before you begin using the Onyx 800R. You'll be glad you did!

Zero the Controls

1. Turn down the channel GAIN controls.
2. Set all push button switches to their "out" positions.
3. Turn the POWER switch off.

Connections

If you already know how you want to connect the Onyx 800R, go ahead and connect the inputs and outputs the way you want them. If you just want to get sound through the preamp, follow these steps:

1. Plug a microphone into channel 1's MIC input.
2. Connect the analog line outputs to your MDM, HDR, or audio interface for your DAW. This requires either a DB25-to-DB25 audio cable or a DB25 breakout cable to either eight male XLR plugs or eight 1/4" TRS plugs.
3. You can connect the Toslink OPTICAL OUT connectors to your recording equipment if they are equipped with Toslink ADAT optical connectors. All eight channels are always present at the LINE LEVEL OUTPUTS and the OPTICAL OUTs up to 96 kHz sampling (four channels at the OPTICAL OUTs at 176.4/192 kHz).
4. You can connect the DB25 AES/EBU OR S/PDIF OUT connector to your recording equipment if they are so equipped, but we recommend that you first read the section on pages 14-15 that describes this output and its associated buttons.

Note: When using the OPTICAL OUTs or the AES/EBU OR S/PDIF OUT, make sure your MDM, HDR, or other audio interface is configured to clock off the incoming digital source. If you try to use their internal clocks, it's simply not going to work right.

5. Plug in the detachable linecord, connect it to an AC outlet, and turn on the Onyx 800R's POWER switch.
6. If the microphone is a dynamic microphone, set the impedance switch on channel 1 to the "D" position (2400 Ω). If it's a condenser microphone, set the impedance switch to the "D" position (or to the manufacturers recommended impedance setting) and push in the 48V phantom power button to turn on the phantom power for channel 1.

Set the Levels

To set the channel GAIN controls, it's not even necessary to hear what you're doing at the outputs of the preamplifier. The following steps must be performed one channel at a time.

1. Play something into the selected input. This could be an instrument, a singing or speaking voice, or a line input such as a CD player or tape recorder output. Be sure that the volume of the input source is the same as it would be during normal use. If it isn't, you might have to readjust these levels later.
2. Adjust the channel's GAIN control so that the "-20" and "0" LEDs light frequently or continuously, and the "OL" LED doesn't light at all (or only flashes occasionally).
3. Repeat for each channel.

Start Recording

1. You should now see the signals from the Onyx 800R appearing on the meters in your MDM, HDR, or DAW. Start recording and hear the Onyx 800R in stunning crystal clarity.

Other Nuggets of Wisdom

- You can connect the analog outputs from any line-level source to the LINE LEVEL INPUTS on the Onyx 800R and use its high-quality analog-to-digital converters to get your analog signals to your digital recorder(s).
- Always turn the Onyx 800R off before making or changing connections.
- When you shut down your equipment, turn off the amplifiers first. When powering up, turn on the amplifiers last.
- Never listen to loud music for prolonged periods. Please see the Safety Instructions on page 2 for information on hearing protection.
- Save the shipping box! You may need it someday, and you don't want to have to pay for another one.

That's it for the "Getting Started" section. Next comes the "Hookup" section that shows you some typical ways that you might use the Onyx 800R in real applications. After that, you can take the grand tour of the Onyx 800R, with descriptions of every knob, button, input, and output. We encourage you to take the time to read all of the feature descriptions, but at least you know it's there if you have any questions.

Hookup Diagrams

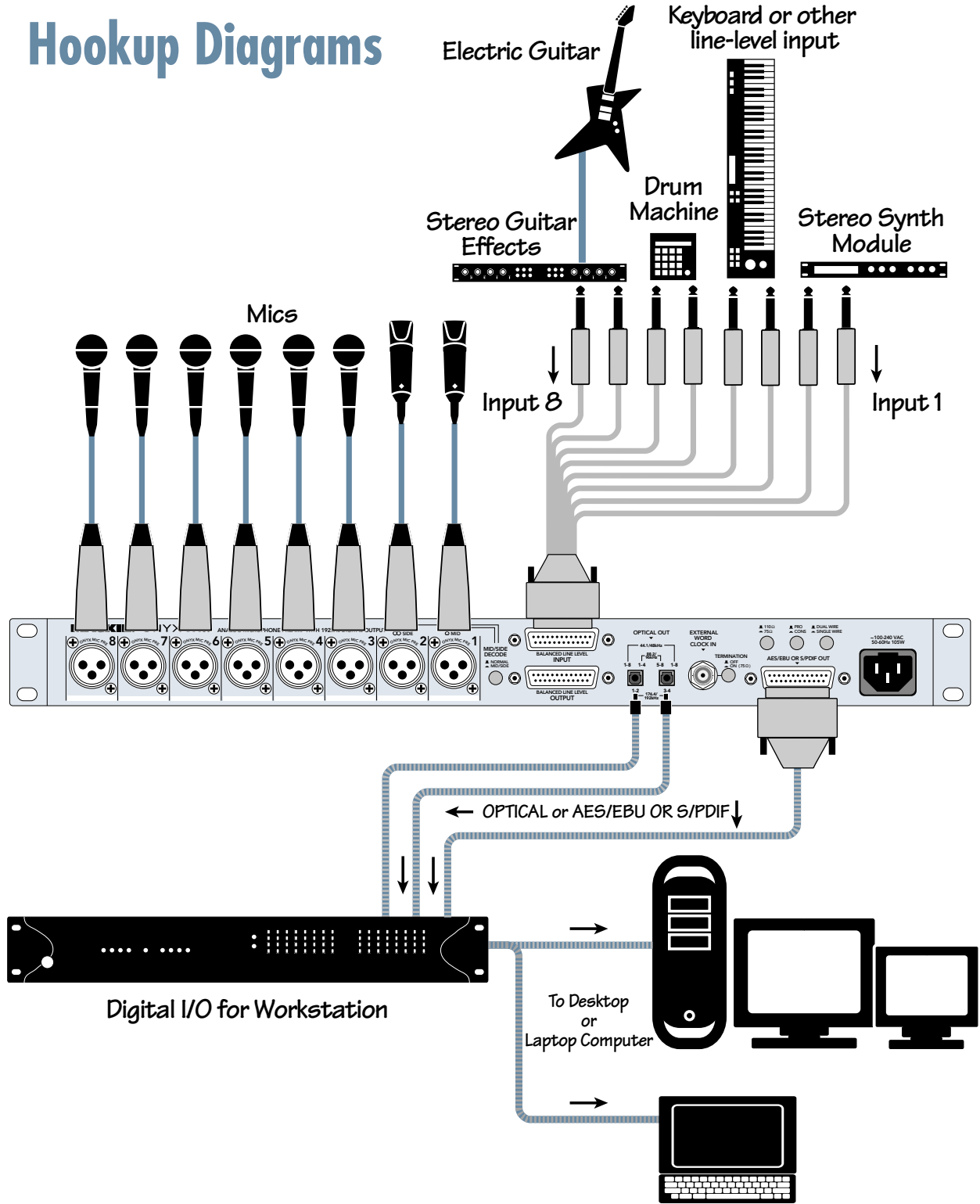

The OPTICAL OUTs or AES/EBU OR S/PDIF OUTs on the Onyx 800R can be connected directly to a digital audio interface for a DAW (Digital Audio Workstation). In this example, use the MIC/LINE switch for each channel to select between the microphones and the line-level input instruments.

Onyx 800R Multitrack Recording with a DAW (Tracking)

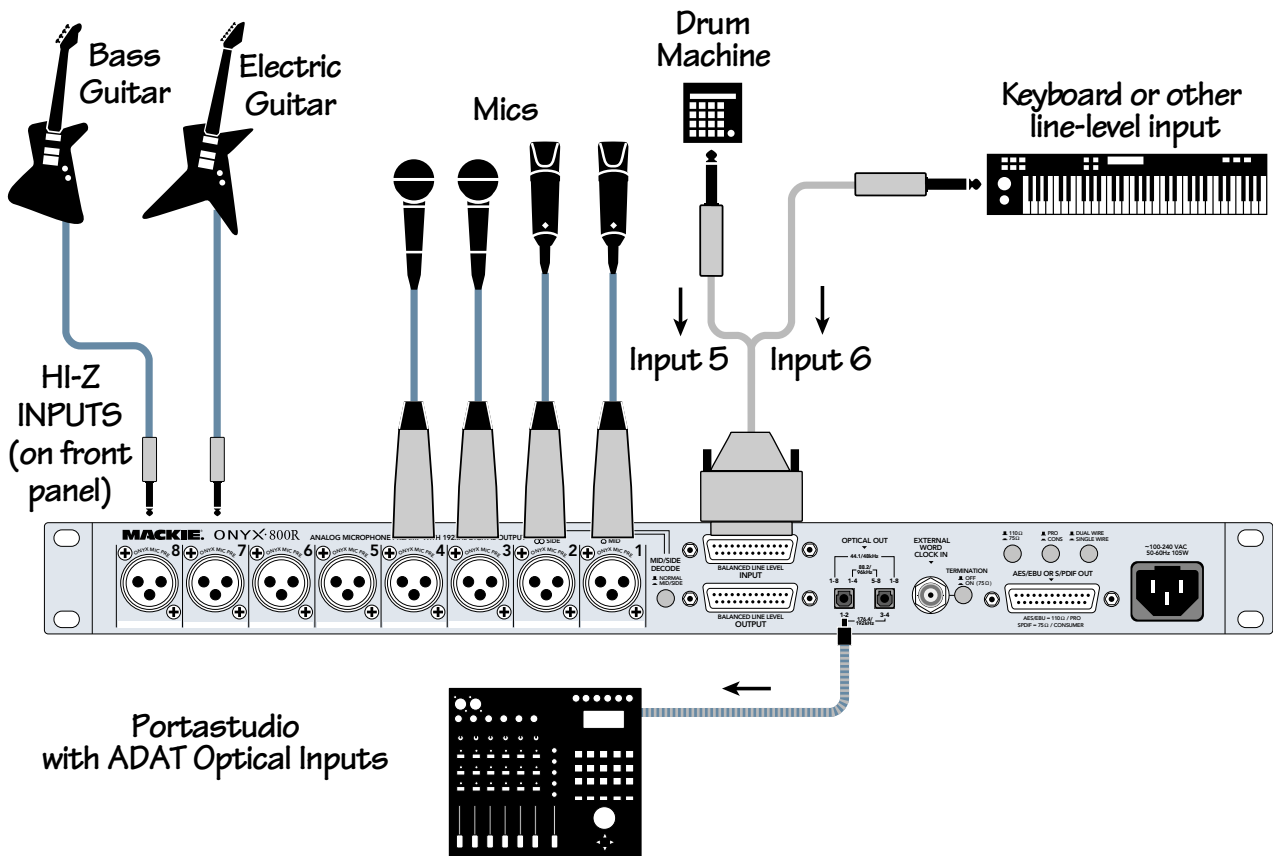

The OPTICAL OUT on the Onyx 800R can be connected directly to a portastudio with ADAT optical inputs.

Onyx 800R Multitrack Recording with a Portastudio (Tracking)

24-Channels
from On-Stage
Mic Splitter

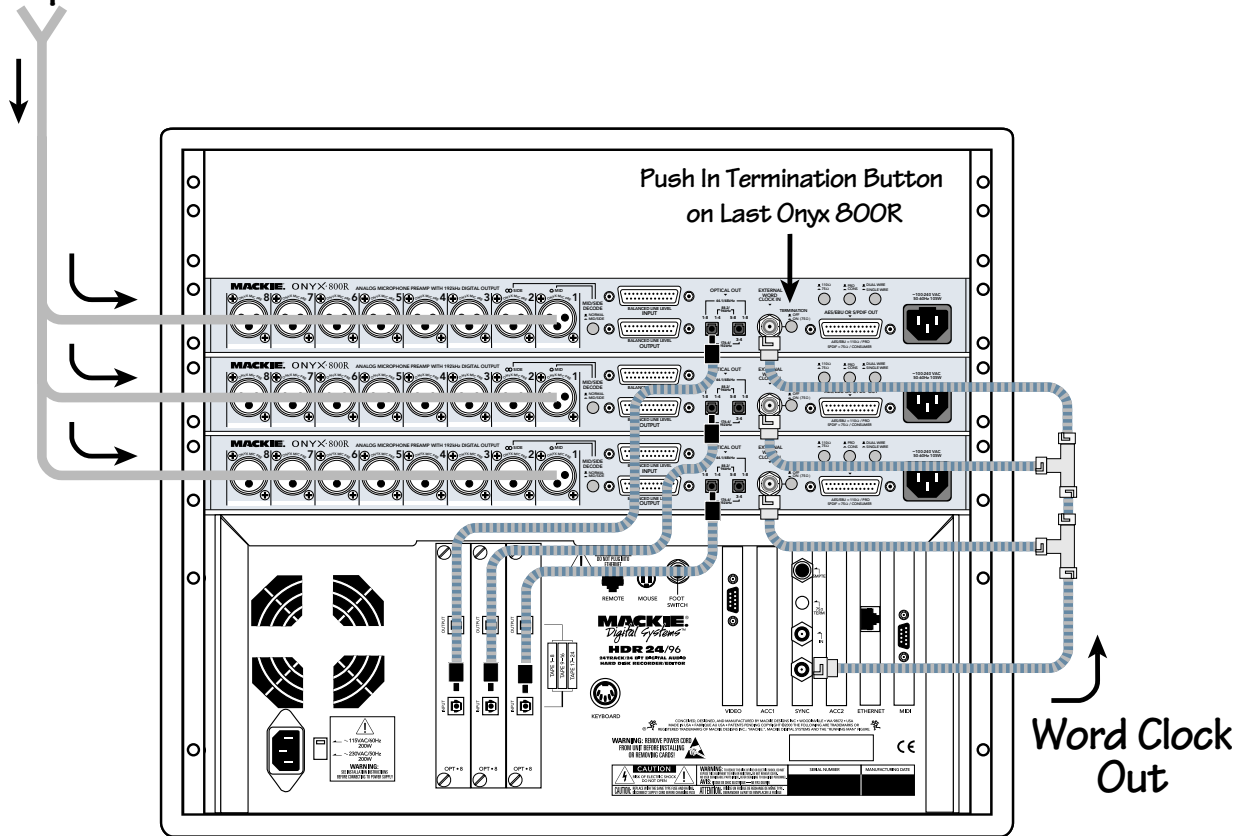

You can use mic splitters to route the signals from the stage to three Onyx 800Rs in a rack, for 24-track live recording to a Mackie HDR.

Onyx 800R Live Multitrack Recording with an HDR

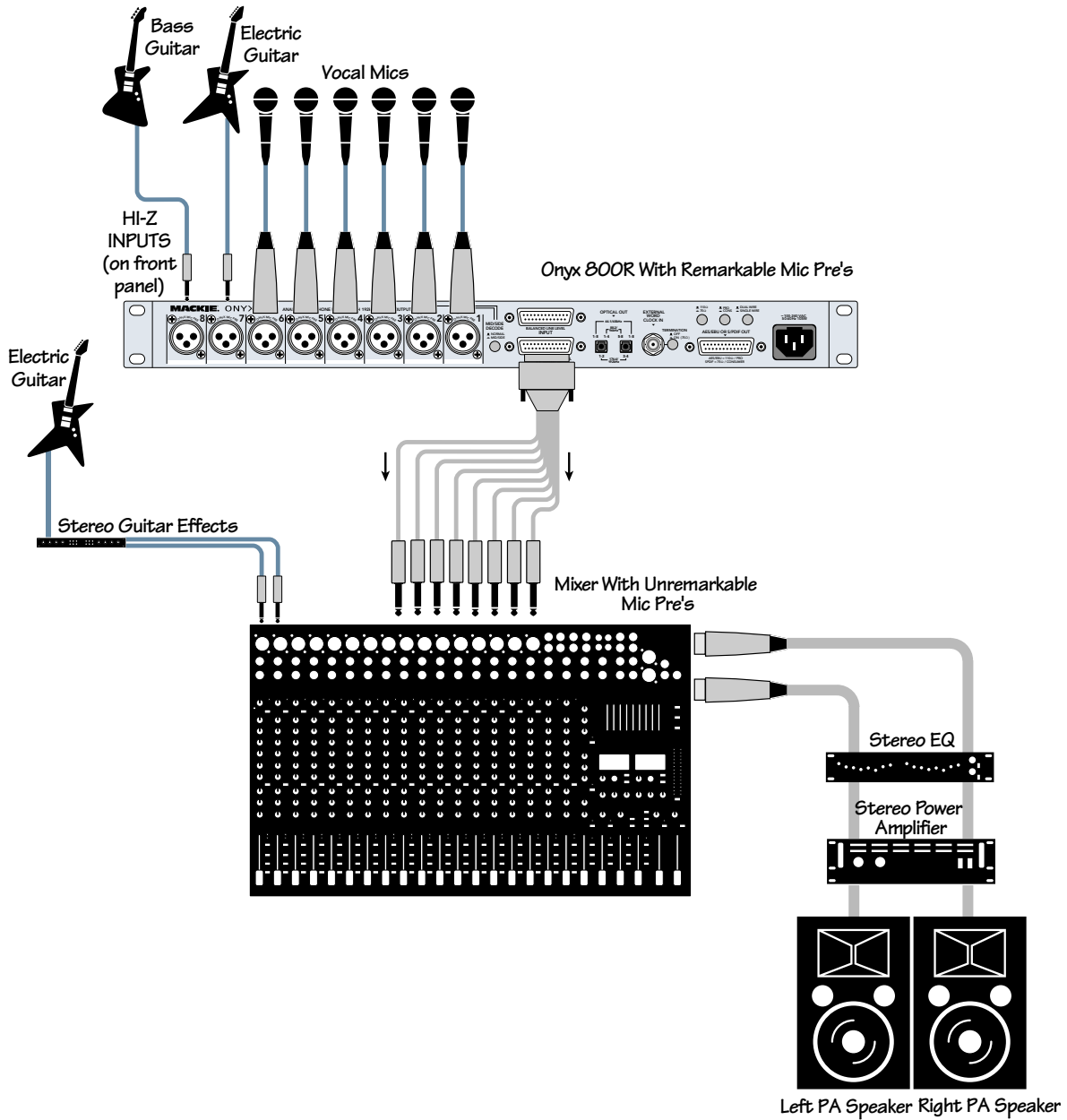

This hookup diagram demonstrates how you can use the balanced line-level outputs on the Onyx 800R in a live mixing application.

Onyx 800R Live Mixing

Onyx 800R Features

Front Panel

There are eight channels in the Onyx 800R. They all share the same features with the exceptions that channels 1 and 2 have an impedance select switch and a mid/side decode switch, and channels 7 and 8 have a high-impedance 1/4" input jack for connecting electric instruments directly to the preamp without a direct box.

1. GAIN Control

The GAIN control adjusts the input sensitivity of the mic and line inputs. This allows the signal from the outside world to be adjusted to optimal internal operating levels.

If the signal is plugged into the XLR jack, there is 0 dB of gain (unity gain) with the knob turned all the way down, ramping up to 60 dB of gain fully up.

When connected to the balanced line input (DB25 connector), there is 20 dB of attenuation all the way down, and 40 dB of gain fully up, with a "U" (unity gain) mark at about 10:00.

2. MIC/LINE Switch

This button selects the input source from either the XLR MIC inputs or the DB25 LINE inputs. When the button is out, the XLR MIC input is used and the line input is disconnected. When the button is pushed in, the DB25 LINE input is used and the XLR MIC input is disconnected. This way, you can leave signals connected to both inputs without having to disconnect one or the other, and the 800R acts as a patchbay for your input sources.

3. MIC IMPEDANCE Switch (Channels 1 and 2)

Many classic, vintage, and ribbon microphones are very sensitive to the input impedance of the mic preamp, and operate best at specific impedances. The MIC IMPED-

ANCE switch allows you to change the input impedance of the microphone inputs on channels 1 and 2. This allows you to change the characteristics of the sound of the microphone.

There are four selections to choose from: A: 300 ohms, B: 500 ohms, C: 1300 ohms, and D: 2400 ohms. Select the impedance that is closest to the recommended impedance for your microphone. Or you can experiment with different settings and decide which one sounds best for your particular application.

Note: The 2400 ohm position (D) matches the nominal input impedances of channels 3-8.

4. Phase Switch

Pushing in this switch simply reverses the polarity of the signal. This provides an easy way to correct a microphone whose polarity is opposite from the other microphones, either from a miswired cable or from not following the AES standard for Pin 2/Pin 3.

5. Low-Cut Switch

The Low-Cut switch, often referred to as a high-pass filter, cuts bass frequencies below 75 Hz at a rate of 18 dB per octave.

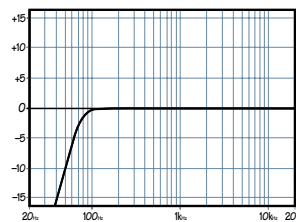

Low Cut

In live situations, this is useful for removing microphone handling noise or stage rumble. It can also be used to reduce the "proximity effect" with certain microphones that accentuates the bass frequencies when a vocalist gets too close to the microphone.

Channel 1

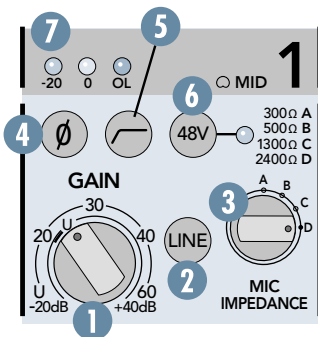

Channel 8

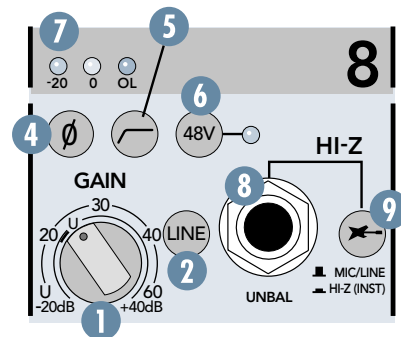

6. 48V Phantom Power Switch

Most professional condenser microphones require phantom power, which is a low-current DC voltage delivered to the microphone on pins 2 and 3 of the XLR microphone connector. Push in the 48V button if your microphone needs phantom power. An LED lights next to the button to indicate that phantom power is active on that channel.

Dynamic microphones, like Shure's SM57 and SM58, do not require phantom power. However, phantom power will not harm most dynamic microphones should you accidentally plug one in while the phantom power is turned on. Be careful with older ribbon microphones. Check the manual for your microphone to find out for sure whether or not phantom power can damage it.

7. Signal Level LEDs

These LEDs indicate the channel's signal level after the GAIN control.

If you've followed the "Set the Levels" procedure on page 5, the -20 and 0 LEDs should light frequently, and the OL (Overload) LED should not light at all. If the OL LED is blinking frequently, the signal is probably distorted from overdriving the input. Either turn down the GAIN control or turn down the signal at its source.

8. UNBAL HI-Z Instrument Input (Channels 7-8)

This is a 1/4" connector, which accepts an unbalanced instrument-level input signal from a high-impedance instrument like a guitar.

9. MIC/LINE/HI-Z (INST) Switch

Channels 7 and 8 have an extra button for switching between the MIC/LINE and HI-Z inputs. When the button is out (MIC/LINE), the XLR MIC input or the DB25 LINE input is used, depending on the setting of the MIC/LINE switch [2], and the HI-Z input is disconnected. When the button is pushed in (HI-Z), the 1/4" HI-Z input is used and the XLR MIC and DB25 LINE inputs are disconnected. The input stage of the HI-Z inputs is specially designed for the high-impedance pickups on electric guitars, basses, acoustic guitar pickups, etc.



Plugging a guitar straight into a typical line input can result in the loss of high frequencies, causing an unnatural and dull sound. Normally, you must use a direct box between a guitar and a mixer's or preamplifier's input, which serves to convert the impedance of the guitar from high to low. The HI-Z inputs on channels 7 and 8 make the need for a direct box unnecessary.

HOWEVER: The HI-Z inputs *are* unbalanced, so if you're doing a live show and running a long cord between the instrument and the mixer (say over 25 or 30 feet), it is best to use a direct box with a balanced output to avoid picking up noise over the length of the cord.

10. POWER Switch

This one is self-explanatory. When the POWER switch is turned ON (up), power is supplied to the Onyx 800R.

11. SAMPLE RATE Switch

Turn this switch to select the sample rate used by the analog-to-digital converters (ADCs) and the digital output.

This eight-position switch offers the following selections: 32 kHz, 44.1 kHz, 48 kHz, 88.2 kHz, 96 kHz, 176.4 kHz, 192 kHz, and EXTERNAL. The LED next to the selected sample rate lights to indicate the sample rate currently being used.

If EXTERNAL is selected, the 800R locks to the external clock connected to the EXTERNAL WORD CLOCK IN connector [19] on the rear panel.

For any of the internal sample rate settings, the ADAT OPTICAL OUT and the AES/EBU OR S/PDIF OUT run at the selected sample rate, which is detected by the device to which the Onyx 800R is connected.

12. LOCK

As described above, if EXTERNAL SAMPLE RATE is selected, the 800R locks to the the EXTERNAL WORD CLOCK IN on the rear panel. If there is not a valid clock connected to the EXTERNAL WORD CLOCK IN, the LOCK LED flashes, indicating the problem. If a valid external clock is detected, the LOCK LED lights continuously and the corresponding sample rate LED will light.

13. BIT DEPTH

This button determines the word length at the digital output, and toggles between 24-bit and 16-bit. The corresponding LED above the button lights to indicate the selection. You might use 24-bit when recording to a 24-track hard disk recorder or DAW, and 16-bit when recording direct to 2-track on a CD-recorder or DAT deck.

When 16-bit is selected, a dithering algorithm is applied to the digital signal to improve the dynamic range and reduce low-level distortion, called quantization noise.

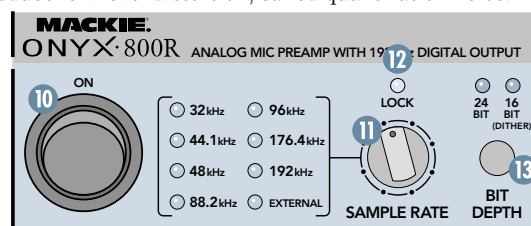

Rear Panel

The rear panel is where you make all your analog and digital audio connections to the Onyx 800R (except for the high-impedance instrument jacks on the front).

14. MIC Inputs

These are female XLR connectors, which accept a balanced microphone input from almost any type of microphone. The microphone preamps feature our new Onyx design, with higher fidelity and headroom rivaling any standalone mic preamp on the market today.

The XLR inputs are wired as follows:

- Pin 1 = Shield or ground
- Pin 2 = Positive (+ or hot)
- Pin 3 = Negative (- or cold)

15. MID/SIDE DECODE

The Onyx 800R has a built-in Mid/Side decoder for stereo mic'ing. The Mid/Side (or M-S) stereo mic'ing technique not only provides a stereo image of the source, but allows you to adjust the width of the image by varying the balance between the Mid (or mono) and Side signals. See "A Closer Look at Mid/Side Recording" below for more info.

When using this technique, connect a cardioid (mid) microphone to channel 1 and a figure 8 (side) microphone to channel 2. Push in the MID/SIDE DECODE button, and the left signal from the decoder is sent to the channel 1 output, and the right signal from the decoder is sent to the channel 2 output.

A CLOSER LOOK AT MID/SIDE RECORDING

A number of stereo recording techniques have been developed over the years including Blumlein, ORTF, spaced pair, and coincident pair, of which X-Y and M-S are a subset. They each have their advantages, depending on the application. Let's look at what the M-S method has to offer.

M-S (Mid-Side) requires the use of two microphones, one with a cardioid pickup and one with a figure-8 (bidirectional) pattern. The cardioid microphone (mid) faces straight forward toward the center of the sound source, while the figure-8 (side) microphone's two elements face sideways, perpendicular to the mid microphone. It is important that the null of the figure 8 mic aligns with the zero degree line of the cardioid.

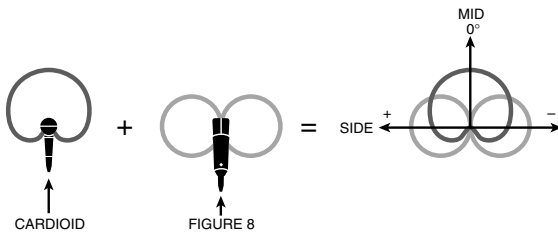

Some microphone manufacturers make stereo mics designed specifically for M-S recording, with all three elements properly aligned in one housing. There's nothing wrong with using two separate microphones, however, as long as the capsules are as coincident (occupying the same space) as possible.

The M-S technique requires a special decoder that produces a left and right stereo signal. The left channel is the sum of the mid and side microphones (M+S), and the right channel is the difference between the mid and side microphones (M-S).

The Onyx 800R has a decoder built-in, which is activated by pushing in the MID/SIDE DECODE button on the rear panel. Connect the MID microphone to channel 1 and the SIDE microphone to channel 2. The signals pass through the decoder just prior to the A/D converters and the analog line outputs.

Stereo recording reproduces the instruments in the same relative locations within the stereo image as they were in the original performance. The side to side stereo image and, to some extent, the front to back depth of image are preserved.

The M-S stereo recording technique allows you to adjust the width of the stereo image by varying the ratio between the mid and side signals. With the 800R, this is accomplished by adjusting the gain controls on channels 1 and 2.

Notice that the adjustments are made prior to the decoder. Adjusting the ratio of the left and right signals after the decoder will not have the same effect. If you want to adjust the stereo image later during mixdown, record the raw MID and SIDE signals to tape with the decoder turned off. Then, when you are doing the final mix, run the recorded MID and SIDE signals through channels 1 and 2 with the decoder turned on and experiment with the gain controls on channels 1 and 2 to adjust the stereo image to your liking.

Another benefit of this recording technique is that the stereo recording is mono compatible. This is especially important for broadcast and film production applications.

16. BALANCED LINE LEVEL INPUT

This is a DB25 connector, which accepts eight balanced line-level input signals from almost any source.

This uses the TASCAM standard pin configuration for balanced analog audio signals (the same standard used on the analog cards for the Mackie D8B and Hard Disk Recorders). Use the LINE switch on the front panel to select these line-level inputs instead of the MIC inputs.

See Appendix B for a wiring diagram of this connector.

17. BALANCED LINE LEVEL OUTPUT

This is a DB25 connector, which provides balanced line-level analog outputs for channels 1-8. It uses the same TASCAM standard pin configuration as the line-level inputs, and is designed to connect directly to a recorder's analog inputs. These outputs are always active regardless of what is happening with the digital outputs.

See Appendix B for a wiring diagram of this connector.

18. OPTICAL OUT

These two Toslink connectors provide a digital output using the ADAT lightpipe format. At higher sample rates, the signal is multiplexed using the S/MUX format.

At 32 kHz, 44.1 kHz, and 48 kHz sample rates: All eight channels are provided on both connectors.

TIP: If you are recording a live show, you can use the second OPTICAL OUT to make a backup recording, "just in case."

At 88.2 kHz and 96 kHz sample rates: Channels 1-4 are provided on the left connector, and channels 5-8 are provided on the right connector, as specified by the S/MUX II protocol for doubled sample rates.

At 176.4 kHz and 192 kHz sample rates: Channels 1-2 are provided on the left connector, and channels 3-4 are provided on the right connector, as specified by the S/MUX IV protocol for quadrupled sample rates.



If you want to use the higher sample rates, check your recording device's owner's manual to make sure the optical inputs support the S/MUX format.

19. EXTERNAL WORD CLOCK IN

This BNC connector receives word clock from another device when the SAMPLE RATE selector on the front panel is set to EXTERNAL. Use this connector when you have multiple devices that must all operate from a master word clock.



Use 75 Ω coaxial cable when connecting a word clock to the EXTERNAL WORD CLOCK IN jack. If there is more than one device to connect to the word clock, either use a master word clock distribution box, which distributes the master word clock to multiple devices, or use a BNC T-adapter to feed the signal on to the next device in the chain (see illustrations below).

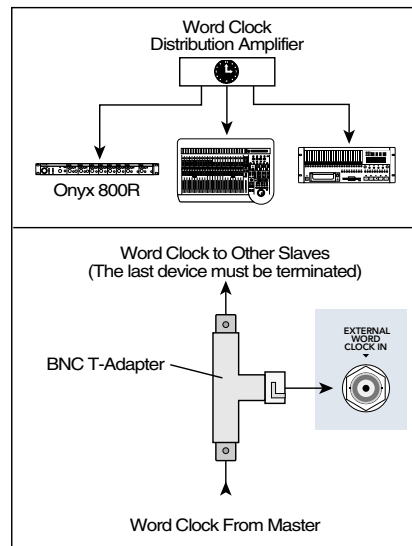

20. TERMINATION

When connecting devices to a word clock, it is important that the connection is properly terminated. If an Onyx 800R is the only device connected to a word clock output, push in the TERMINATION button to terminate the connection with 75 ohms impedance.

If two or more Onyx 800Rs (or other devices) are connected to a word clock output in a daisy-chain fashion, as illustrated in the hookup diagram on page 8, leave the termination button out on all the Onyx 800Rs except for the last one in the chain. *Remember, the last device in the chain is the one that should be terminated with 75 ohms.*

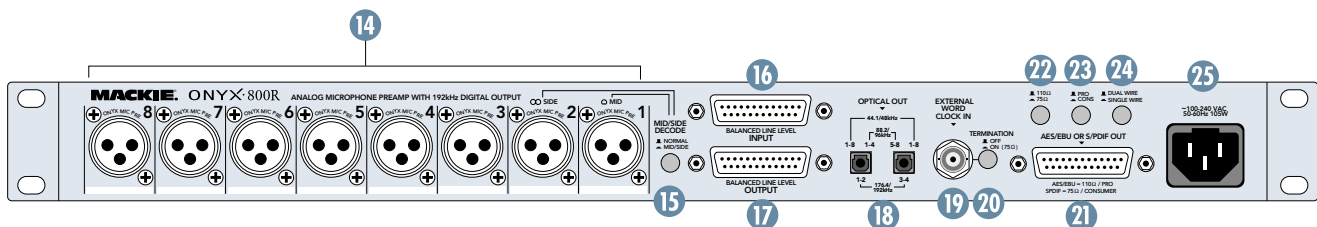

21. AES/EBU OR S/PDIF OUT

This DB25 connector produces a digital output for all eight channels in either AES/EBU format (PRO) or S/PDIF format (CONS). The audio data is the same for either format, but the electrical characteristics (voltage level, impedance) and non-audio data bits (subcode) are different.

This can be connected directly to a recording device with AES/EBU or S/PDIF inputs using an appropriate digital recorder interface cable.



By the way, the most wonderful thing about standards is that there are so many to choose from. A variety of alternate pin-out configurations are being used by various manufacturers for the AES/EBU DB25 interface. You will need to make a conversion cable when connecting between two devices that use different pin-outs for the AES/EBU or S/PDIF DB25 connectors. See Appendix B for a wiring diagram of this connector.

For AES/EBU connections:

1. Most devices use a balanced 3-pin XLR connector for two-channel inputs, or a 25-pin DB25 connector for eight channels. Special AES/EBU cables are available from various manufacturers with DB25 connectors on both ends, or breakout cables are available for making digital audio connections from DB25 to XLR.

These off-the-shelf cable harnesses have four male XLRs for the outputs, and four female XLRs for the inputs. Since the Onyx 800R only has digital outputs, you won't use the female connectors.

2. If you want a more streamlined cable harness, you can make your own (or have one made) with only the four connectors.

For S/PDIF connections:

1. Most devices use an RCA connector for two-channel inputs, or a 25-pin DB25 connector for eight channels. Your best option for connecting to devices with RCA jacks is to use an AES/EBU breakout cable described above, and fit it with XLR-to-RCA adapters (or build your own custom cable harness with four RCA connectors on it). Use a DB25-to-DB25 AES/EBU cable for devices with DB25 S/PDIF connections.



Note: Transferring digital audio over a cable generates EMI (electromagnetic interference) around the cable. Use a high-quality shielded cable to minimize the EMI noise radiated around the cable. For example, Belden's 7880A cable shields each individual pair of wires as well as the entire cable, and is recommended by Belden for AES/EBU digital audio.



In general, the shorter the cable length, the less effect it has on the quality of the signal. The maximum length for an AES/EBU cable is 100 meters (about 325 feet), and a S/PDIF cable is limited to 10 meters (about 32 feet).

The three buttons located just above the AES/EBU OR S/PDIF OUT connector can be used to customize the digital signal. The 110Ω/75Ω and PRO/CONS buttons in particular give you added flexibility when interfacing with “finicky” digital inputs.

22. 110Ω/75Ω Switch

If you are using the AES/EBU format, the output is a balanced differential signal at a voltage specified at between 2 to 7 V peak-to-peak into 110 ohms. In the S/PDIF format, the output signal is unbalanced at a voltage of 0.5 V peak-to-peak into 75 ohms. So use the 110Ω position for AES/EBU, and the 75Ω position for S/PDIF.

Note: If you are using any kind of adapter to convert an AES/EBU connector to a S/PDIF connector, check to see if the adapter converts the impedance as well as the connector type. If this is the case, leave the 110Ω/75Ω switch in the 110Ω position. Only use the 75Ω position with true 75-ohm coaxial cable connected directly to a S/PDIF input.

23. PRO/CONS Switch

Use this switch to select between the professional AES/EBU format or the consumer S/PDIF format.

Note: Strictly speaking, AES/EBU can transmit up to 24-bits, while S/PDIF is limited to 20-bits because four bits are reserved for “user bits.” However, if 24-bit depth is selected, the four user bits are used for digital audio and 24-bits are transmitted (this is an accepted optional implementation of S/PDIF).

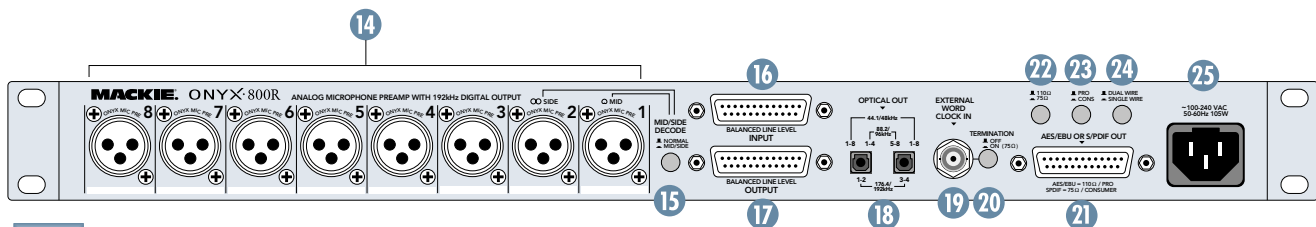

24. DUAL WIRE/SINGLE WIRE Switch

The original AES/EBU specification (IEC958 Type 1) provides for carrying two channels of digital audio at resolutions up to 24-bit at 48 kHz. When higher sampling rates became possible, two methods were developed to transmit the digital audio at the higher sample rates—double-fast and double-wide.

The double-fast method (single wire) clocks the digital I/O port at twice the speed to get twice the information through, providing support for resolutions up to 24-bit at 96 kHz.

The double-wide method (dual wire) transmits one channel of digital audio instead of two channels through a single digital I/O port, again providing support for resolutions up to 24-bit at 96 kHz.

This presents a problem when interconnecting digital audio equipment. Devices using the double-fast method can't talk to devices using the double-wide method. Remember the old Beta vs. VHS format wars? Maybe not. Well, the Onyx 800R has solved this dilemma with the flip of a switch! Here's how it works:

At sampling rates up to 48 kHz: The position of the DUAL WIRE/SINGLE WIRE switch doesn't matter. Two channels of digital audio are transmitted on a single wire (one 3-pin XLR) as specified by the AES/EBU standard.

At sampling rates of 88.2 kHz through 192 kHz: When connecting to devices that use the double-fast method, set the switch to the SINGLE WIRE position. This transmits two channels on a single wire (3-pin XLR) at twice the speed (88.2/96 kHz) or four times the speed (176.4/192 kHz). When connecting to devices that use the double-wide method, set the switch to the DUAL WIRE position. This transmits one channel on one wire (one 3-pin XLR) at normal speed (88.2/96 kHz) or twice the speed (176.4/192 kHz), but using twice the bandwidth. In the DUAL WIRE position at these sampling rates, only channels 1-4 are available.

Check the owner's manual for the device you are connecting to the Onyx 800R, to find out which method it supports.

Note: The analog and optical outputs are not affected by the AES/EBU OR S/PDIF OUT settings.

25. Power Receptacle

This is a standard 3-prong IEC power connector. Connect the detachable linecord (included in the box with your Onyx 800R) to the power receptacle, and plug the other end of the linecord into an AC outlet. The Onyx 800R has a universal power supply that can accept any AC voltage ranging from 100 VAC to 240 VAC. No need for voltage select switches. It will work virtually anywhere in the world. That's why we call it a "Planet-Earth" power supply! This also means that it is less susceptible to voltage sags or spikes, providing greater electromagnetic isolation and better protection against AC line noise.

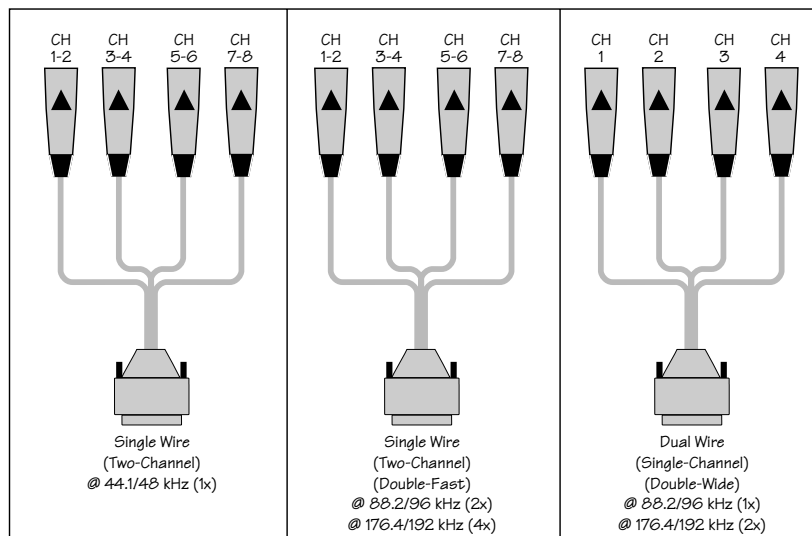

Appendix A: Service Information

Warranty Service

Details concerning Warranty Service are spelled out in the Warranty section on page 23.

If you think your Onyx preamp has a problem, please do everything you can to confirm it before calling for service. Doing so might save you from the deprivation of your Onyx preamp and the associated suffering.

These may sound obvious to you, but here are some things you can check. Read on.

Troubleshooting

No Power

- Our favorite question: Is it plugged in?
- Make sure the power cord is securely seated in the IEC socket [25] and plugged all the way into the AC outlet.
- Make sure the AC outlet is live (check with a tester or lamp).
- Is the POWER [10] switch on? Make sure the POWER switch on the front panel is in the ON position (up).
- Are any LEDs on the front panel illuminated? If not, make sure the AC outlet is live.
- Are all the lights out in your building? If so, contact your local power company to get power restored.
- If there are no LEDs illuminated on the front panel, and you are certain that the AC outlet is live, it will be necessary to have your Onyx 800R serviced. *There are no user serviceable parts inside.* Refer to “Repair” at the end of this section to find out how to proceed.

Bad Channel

- Is the LINE switch [2] in the correct position?
- Is the input GAIN control [1] for the channel turned up?
- Is the signal source turned up? Make sure the signal level from the selected input source is high enough to light up some of the INPUT meter [7] LEDs for that channel.
- If it is channel 7 or 8, make sure the MIC/LINE/HI-Z switch [9] is in the right position.
- Try the same source signal in another channel, set up exactly like the suspect channel.

Bad Output

- If it's the BALANCED LINE LEVEL OUTPUT [17], make sure the DB25 connector is correctly wired (see Appendix B: Connections).
- If it's the OPTICAL OUT [18], make sure the optical cable isn't kinked or damaged, and that the connectors are securely seated at both ends.
- If it's the AES/EBU OR S/PDIF OUT [21], make sure the DB25 connector is correctly wired (see Appendix B: Connections). Determine if the device to which the Onyx 800R is connected is operating in SINGLE WIRE or DUAL WIRE mode. Make sure the buttons above the AES/EBU OR S/PDIF OUT connector are in the correct positions.

Bad Sound

- Is the input connector plugged completely into the jack?
- Is it loud and distorted? Make sure the input GAIN control for the channel is set correctly. Reduce the signal level on the input source if possible.
- Are the Onyx 800R and the device to which it is connected locked to the same clock rate? If the Onyx 800R is operating on its own internal sample rate, make sure the device to which it is connected is set to external clock and is locking to the word clock either through the OPTICAL or the AES/EBU OR S/PDIF connections. If the Onyx 800R is set to EXTERNAL clock, make sure the LOCK LED is lit.
- If possible, listen to the signal with headphones plugged into the input source device. If it sounds bad there, it's not the Onyx causing the problem.

Noise/Hum

- Turn down each channel, one by one. If the noise disappears, it's coming from whatever is plugged into that channel.
- Check the signal cables between the input sources and the Onyx. Disconnect them one by one. When the noise goes away, you'll know which input source is causing the problem.
- Sometimes it helps to plug all the audio equipment into the same AC circuit so they share a common ground.
- Make sure you are using shielded cable designed for digital audio transmission, like Belden 7880A.

Repair

Service for Mackie products is available at our galactic headquarters, located in sunny Woodinville, Washington. Service for Mackie products living outside the United States can be obtained through local dealers or distributors.

If your Onyx 800R needs service, follow these instructions:

1. Review the preceding troubleshooting suggestions. Please.
2. Call Tech Support at 1-800-898-3211, 7 am to 5 pm PST, to explain the problem and request an RA (Return Authorization) number. Have your Onyx 800R's serial number ready. **You must have an RA number before you can obtain service at the factory.**
3. Keep this owner's manual and the detachable linecord. We don't need them to repair the mixer.
4. Pack the preamplifier in its original package, including endcaps and box. This is **VERY IMPORTANT**. When you call for the RA number, please let Tech Support know if you need new packaging. *Mackie is not responsible for any damage that occurs due to non-factory packaging.*
5. Include a legible note stating your name, shipping address (no P.O. boxes), daytime phone number, RA number, and a detailed description of the problem, including how we can duplicate it.
6. Write the RA number in **BIG PRINT** on top of the box. Units sent to us without the RA number will be refused.
7. Ship the preamplifier to us. We suggest insurance for all forms of cartage. Ship to this address:

MACKIE
SERVICE DEPARTMENT
16220 Wood-Red Road NE
Woodinville, WA 98072
8. We'll try to fix the preamplifier within three to five business days. Ask Tech Support for the latest turn-around times when you call for your RA number. The preamp must be packaged in its original packing box, and must have the RA number on the box. Once it's repaired, we'll ship it back the same way in which it was received. This paragraph does not necessarily apply to non-warranty repair.

Note: You must have a sales receipt from an Authorized Mackie Dealer to qualify for a warranty repair.

Need Help?

**You can reach a technical support representative
Monday through Friday
from 7 AM to 5 PM PST at:**

1-800-898-3211

**After hours, visit www.mackie.com and click Support,
or email us at: techmail@mackie.com**



Appendix B: Connections

XLR Connectors

Channels 1-8 use 3-pin female XLR connectors on the MIC inputs. They are wired as follows, according to standards specified by the AES (Audio Engineering Society).

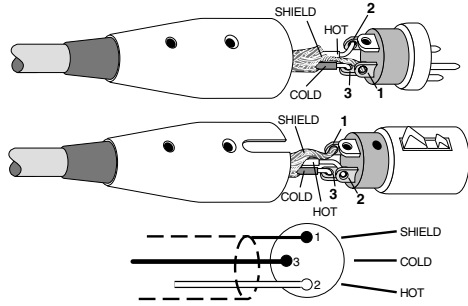

XLR Balanced Wiring:

- Pin 1 = Shield
- Pin 2 = Hot (+)
- Pin 3 = Cold (-)

1/4" TRS Phone Plugs and Jacks

"TRS" stands for Tip-Ring-Sleeve, the three connection points available on a stereo 1/4" or balanced phone jack or plug. TRS jacks and plugs are used for balanced signals and stereo headphones. Neither of these are used on the Onyx 800R, but we're including them anyway, for your reference.

Balanced Mono

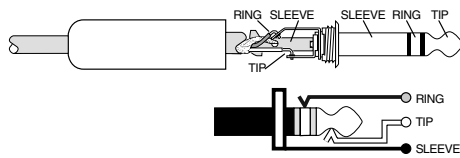

1/4" TRS Balanced Mono Wiring:

- Sleeve = Shield
- Tip = Hot (+)
- Ring = Cold (-)

Stereo Headphones

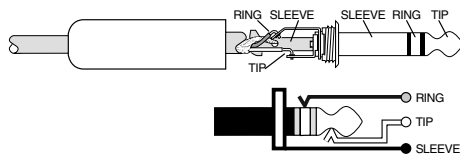

1/4" TRS Stereo Unbalanced Wiring:

- Sleeve = Shield
- Tip = Left
- Ring = Right

1/4" TS Phone Plugs and Jacks

"TS" stands for Tip-Sleeve, the two connection points available on a mono 1/4" phone jack or plug. They are used for unbalanced signals like the high-impedance instrument inputs on the Onyx 800R.

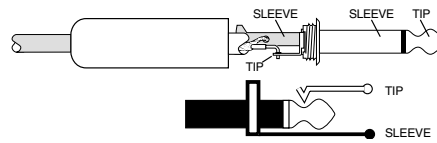

1/4" TS Unbalanced Wiring:

- Sleeve = Shield
- Tip = Hot (+)

RCA Plugs and Jacks

RCA-type plugs (also known as phono plugs) and jacks are often used in home stereo and video equipment, and to make S/PDIF connections on consumer digital audio devices. They are unbalanced and electrically equivalent to a 1/4" TS phone plug.

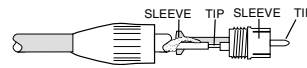

RCA Unbalanced Wiring:

- Sleeve = Shield
- Tip = Hot (+)

Unbalancing a Line

In most studio, stage, and sound reinforcement situations, there is a combination of balanced and unbalanced inputs and outputs on the various pieces of equipment. This usually will not be a problem in making connections.

- When connecting a balanced output to an unbalanced input, be sure the signal high (hot) connections are wired to each other, and that the balanced signal low (cold) goes to the ground (earth) connection at the unbalanced input. In most cases, the balanced ground (earth) will also be connected to the ground (earth) at the unbalanced input. If there are ground-loop problems, this connection may be left disconnected at the balanced end.

- When connecting an unbalanced output to a balanced input, be sure that the signal high (hot) connections are wired to each other. The unbalanced ground (earth) connection should be wired to the low (cold) and the ground (earth) connections of the balanced input. If there are ground-loop problems, try disconnecting the unbalanced ground (earth) connection from the balanced input ground (earth) connection, leaving the unbalanced ground connected to the balanced input low (cold) connection only.

In some cases, you may have to make up special adapters to interconnect your equipment. For example, you may need a balanced XLR female connected to an unbalanced 1/4" TS phone plug. Many common adapters can be found at your local electronics supply store.

DB25 Connectors

Analog

The BALANCED LINE LEVEL INPUTs and BALANCED LINE LEVEL OUTPUTs on the back of the Onyx 800R provide balanced inputs and outputs for channels 1-8 on two female DB25 connectors. These connectors are pin-for-pin compatible with the analog (not TDIF) DB25 connectors found on TASCAM DTRS recorders, which has become an industry standard for many professional audio manufacturers. They are also the same pinout as the analog cards for the Mackie D8B and hard disk recorders.

Each DB25 connector provides eight balanced line-level inputs or outputs.

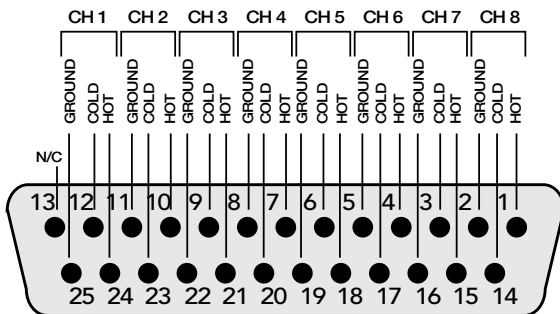

Analog DB25 Line-Level Input and Output

Several companies make DB25-to-DB25 cables specifically for audio, with proper shielding to reduce crosstalk and noise.

DB25 cables that break out to XLR, 1/4" TRS, or TT connectors for connecting to other mixers or audio gear are also readily available. See your Mackie dealer for details.

Digital

The AES/EBU OR S/PDIF OUT connector provides a digital output for all eight channels. If you have this output configured for AES/EBU, which is a balanced output, the connector is wired as follows:

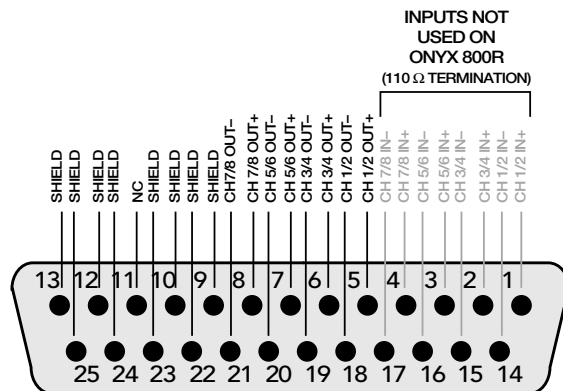

Digital DB25 AES/EBU Output

If you have this output configured for S/PDIF, which is an unbalanced output, the connector is wired as follows:

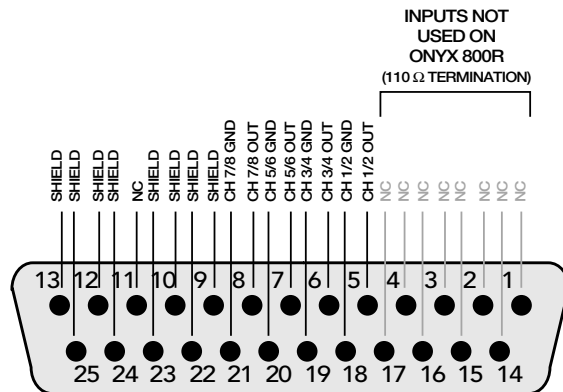

Digital DB25 S/PDIF Output

If you are using the DUAL WIRE position with the higher sample rates (88.2 kHz and up), the same cabling that you use for the SINGLE WIRE position will work as long as you have it connected to another device using the same method.

Note: A variety of alternate pin-out configurations have been developed by various manufacturers for the AES/EBU DB25 interface. Make sure the device you are connecting to has the same pin-out configuration as the Onyx 800R. If not, you will need to make a conversion cable so the signals arrive at the correct pins on the receiving end of the cable.

Appendix C: Technical Info

Onyx 800R Specifications

Frequency Response

Mic Input to Line Output (Gain @ unity):
 +0, -0.1 dB, 20 Hz to 30 kHz
 +0, -3 dB, 10 Hz to 170 kHz

Mic Input to Digital Output (AES, 192 kHz sample rate):
 +0, -0.2 dB, 20 Hz to 85 kHz
 +0, -1 dB, 10 Hz to 90 kHz

Distortion (THD & IMD)

Mic Input to Line Output (@ +4 dBu output):
 THD+N: < 0.0007%, 20 Hz to 20 kHz BW, 1 kHz input
 @ +4 dBu, preamp at unity gain
 THD+N: < 0.002%, 10 Hz to 30 kHz BW, 1kHz input
 @ 10mV rms (-37.8 dBu)
 SMPTE IMD: < 0.005% (4:1 IMD)

Mic Input to Digital Output (AES, 48 kHz sample rate):
 THD+N: < 0.004%, 10mV rms input,
 gain at -1 dB FS output

Dynamic Range

>123 dB (Mic In to Line Out)
 >113 dB (through A-to-D converters)

Noise

Signal-to-Noise (A-weighted):
 >103 dB (ref. +4 dBu, Mic In to Line Out, Gain @ unity)

Equivalent Input Noise (E.I.N.), 20 Hz to 20 kHz Bandwidth,
 150Ω source impedance:
 -129 dBu @ +60 dB gain

Residual Output Noise:
 Line Out: < -102 dBu (Channel Gain at unity)
 Digital Out (AES, 48 kHz): < -113 dB FS

Common Mode Rejection Ratio (CMRR)

Mic In: >60 dB @ 1 kHz, Gain @ maximum

Crosstalk

Mic Input to Line Output:
 < -100 dB @ 1 kHz, +10 dBu signal on adjacent
 input, 150Ω source impedance

Input Gain Control Range

Mic In: 0 dB to +60 dB
 Line In: -20 dB to +40 dB

Phantom Power

+48 VDC

Equalization

High-Pass Filter: 75 Hz @ 18 dB/octave

Rated Output

Line: +4 dBu
 Maximum Rated Output:
 +24 dBu @ Balanced Line-Level Outputs

Maximum Input Levels

Mic Input: +22 dBu, Gain @ unity
 Inst Input: +21 dBu, Gain @ -20 dB
 Line Input: > +22 dBu, Gain @ -20 dB

Input Impedance

Ch 1 and 2 Mic Input:
 300Ω, 500Ω, 1.3 kΩ, or 2.4 kΩ balanced

Ch 3 through 8 Mic Input:
 2.4 kΩ balanced

Inst Input: 1 MΩ
 Line: 20 kΩ balanced, 10 kΩ unbalanced

Output Impedance

Line: 100 Ω balanced

Signal Level LEDs

-20 dBu, 0 dBu (normal operating level), OL = 22 dBu

Sample Frequency Selections

32 kHz, 44.1 kHz, 48 kHz, 88.2 kHz, 96 kHz,
 176.4 kHz, 192 kHz, External

Bit Depth Selections

24-bit (full range from converters), 16-bit (dithered)

Analog Input Connectors

Eight balanced XLR mic inputs
 Two 1/4" TS high-impedance instrument inputs
 One DB25 connector with eight balanced line-level inputs

Analog Output Connectors

One DB25 connector with eight balanced line-level
 outputs

Digital Input Connectors

One BNC connector for external word clock input

Digital Output Connectors

Two Toslink Optical Connectors
 Both transmit channels 1-8 at 44.1/48 kHz operation

One transmits channels 1-4 and one transmits
 channels 5-8 at 88.2/96 kHz operation using
 S/MUX standard

One transmits channels 1-2 and one transmits
 channel 3-4 at 176.4/192 kHz operation using
 S/MUX standard

One DB25 Connector

Transmits AES/EBU or S/PDIF formatted digital
 audio with single-wire/dual-wire options available at
 all sample rates

AC Power Requirements

Power Consumption: 45 watts

Universal AC Power Supply:
100 VAC – 240 VAC, 50-60 Hz

Physical Dimensions and Weight

Height: 1.75 in/44 mm
 Width: 17.75 in/451 mm (main body of unit)
 19.00 in/483 mm (with rack ears)
 Depth: 14.38 in/365 mm (including front knobs and rear BNC jack)
 Weight: 10.6 lb/4.8 kg

LOUD Technologies Inc. is always striving to improve our products by incorporating new and improved materials, components, and manufacturing methods. Therefore, we reserve the right to change these specifications at any time without notice.

“Mackie,” “Onyx,” and the “Running Man” are registered trademarks of LOUD Technologies Inc. All other brand names mentioned are trademarks or registered trademarks of their respective holders, and are hereby acknowledged.

©2004 LOUD Technologies Inc. All Rights Reserved.

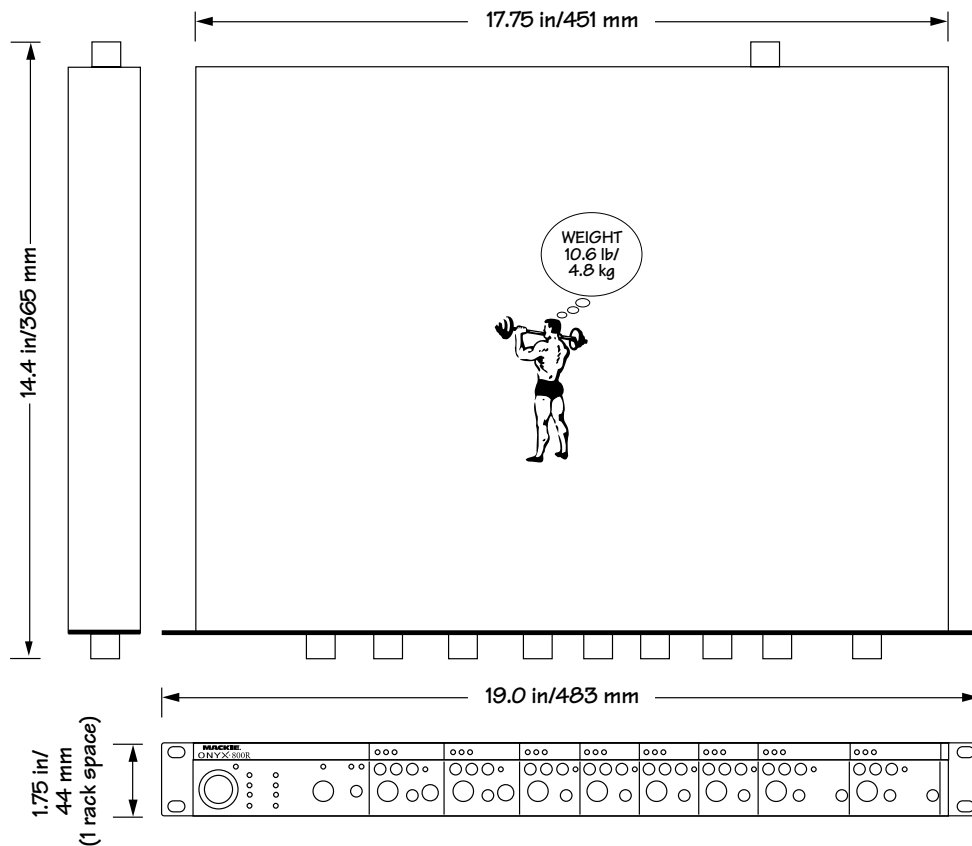

Onyx 800R Block Diagram

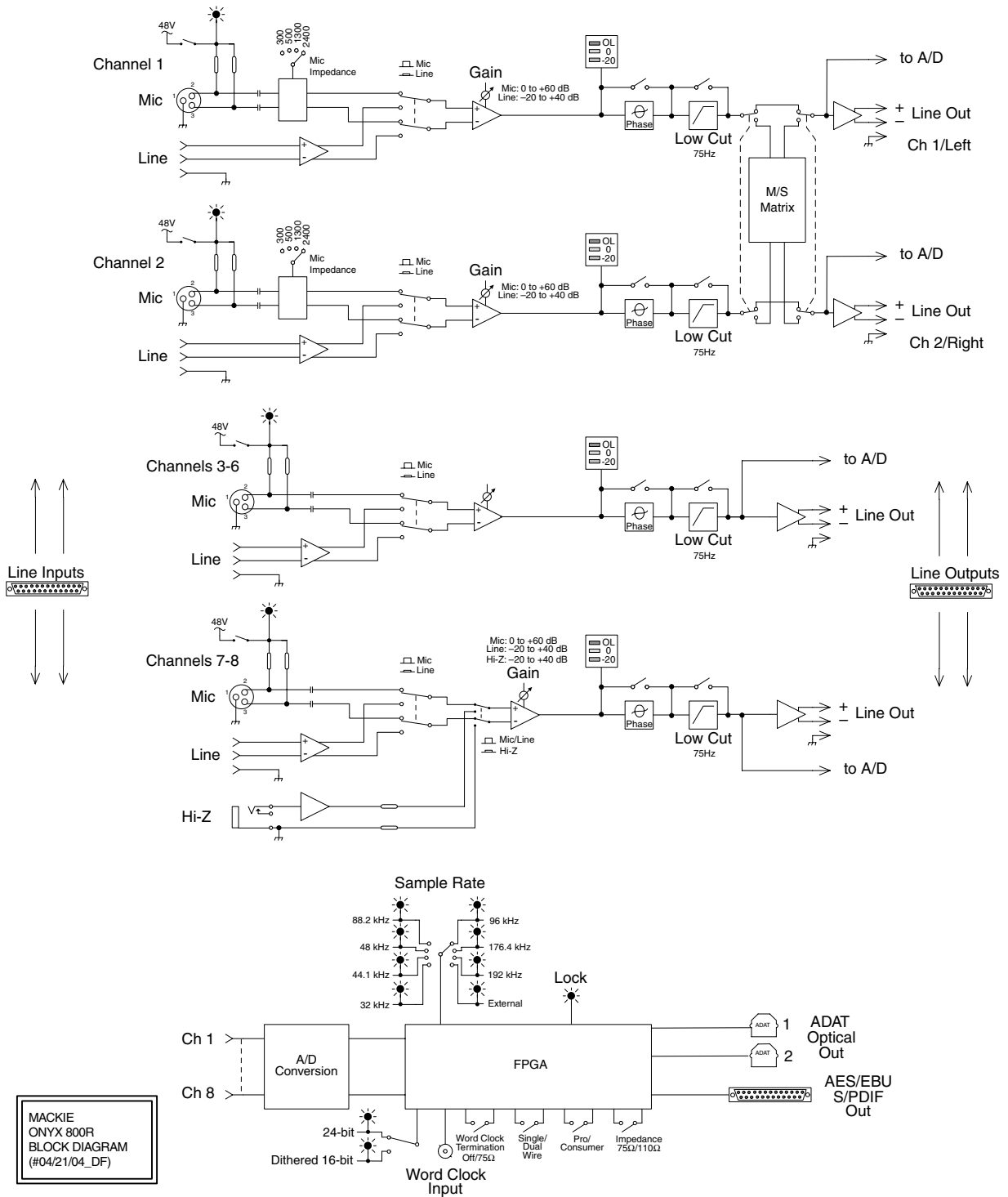

MACKIE
ONYX 800R
BLOCK DIAGRAM
(#04/21/04_DF)

Onyx 800R Limited Warranty

Please keep your sales receipt in a safe place.

A. LOUD Technologies Inc. warrants all materials, workmanship and proper operation of this product for a period of **three years** from the original date of purchase. If any defects are found in the materials or workmanship or if the product fails to function properly during the applicable warranty period, LOUD Technologies, at its option, will repair or replace the product. **This warranty applies only to equipment sold and delivered within the U.S. by LOUD Technologies Inc. or its authorized dealers.**

B. Failure to register online or return the product registration card will not void the three-year warranty.

C. Service and repairs of Mackie products are to be performed **only** at the factory (see D below) OR at an Authorized Mackie Service Center (see E below). Unauthorized service, repairs, or modification will void this warranty. To obtain repairs under warranty, you must have a copy of your sales receipt from the store where you bought the product. It is necessary to establish purchase date and thus determine whether or not your Mackie product is still under warranty.

D. To obtain factory service:

1. Call Mackie Service at 800/898-3211, 7 AM to 5 PM Monday through Friday (Pacific Time) to get a Return Authorization (RA). Products returned without an RA number will be refused.

2. Pack the product in its original shipping carton. If you do not have the carton, just ask for one when you get your RA number, and we'll send a shipping carton out promptly. More information on packing can be found in the *Service* section of this manual. Please seal the Mackie product in a plastic bag.

3. Also include a note explaining exactly how to duplicate the problem, a copy of the sales receipt with price and date showing, and your return street address (no P.O. boxes or route numbers, please!). If we cannot duplicate the problem or establish the starting date of your Limited Warranty, we may, at our option, charge for service time.

4. Ship the product in its original shipping carton, **freight prepaid** to:

MACKIE SERVICE DEPARTMENT
16220 Wood-Red Road NE
Woodinville, WA, 98072, USA

IMPORTANT: Make sure that the RA number is plainly written on the shipping carton.

E. To obtain service from an Authorized Mackie Service Center:

1. Call Mackie Service at 800/898-3211, 7 AM to 5 PM Monday through Friday (Pacific Time) to get: 1) The name and address of your nearest Authorized Mackie Service Center and 2) A return authorization (RA). You must have an RA number before taking your unit to a service center.

2. Make sure that you have a copy of your sales receipt from the store where you bought the product. If you can't find it, the Authorized Service Center may charge you for repairs even if your Mackie product is still covered by the Three-Year Limited Warranty.

3. Make sure that the problem can be duplicated. If you bring your Mackie product to an Authorized Service Center and they can't find anything wrong with it, you may be charged a service fee.

4. If the Authorized Mackie Service Center is located in another city, pack the mixer in its original shipping carton. More information on packing can be found in the *Service* section of this manual.

5. Contact the Authorized Mackie Service Center to arrange service or bring the Mackie product to them.

F. LOUD Technologies and Authorized Mackie Service Centers reserve the right to inspect any products that may be the subject of any warranty claims before repair or replacement is carried out. LOUD Technologies and Authorized Mackie Service Centers may, at their option, require proof of the original date of purchase in the form of a dated copy of the original dealer's invoice or sales receipt. Final determination of warranty coverage lies solely with LOUD Technologies or its Authorized Service Centers.

G. Mackie products returned to LOUD Technologies and deemed eligible for repair or replacement under the terms of this warranty will be repaired or replaced within thirty days of receipt by LOUD Technologies. LOUD Technologies may use refurbished parts for repair or replacement of any product. Products returned to LOUD Technologies that do not meet the terms of this Warranty will not be repaired and returned until payment is received for labor, materials, return freight, and insurance. Products repaired under warranty at the factory will be returned freight prepaid by LOUD Technologies to any location within the boundaries of the USA.

H. LOUD Technologies warrants all repairs performed for 90 days or for the remainder of the warranty period. This warranty does not extend to damage resulting from improper installation, misuse, neglect or abuse, or to exterior appearance. This warranty is recognized only if the inspection seals and serial number on the unit have not been defaced or removed.

I. LOUD Technologies assumes no responsibility for the quality or timeliness of repairs performed by Authorized Mackie Service Centers.

J. This warranty is extended to the original purchaser and to anyone who may subsequently purchase this product within the applicable warranty period. A copy of the original sales receipt is required to obtain warranty repairs.

K. This is your sole warranty. LOUD Technologies does not authorize any third party, including any dealer or sales representative, to assume any liability on behalf of LOUD Technologies or to make any warranty for LOUD Technologies Inc.

L. THE WARRANTY GIVEN ON THIS PAGE IS THE SOLE WARRANTY GIVEN BY LOUD TECHNOLOGIES INC. AND IS IN LIEU OF ALL OTHER WARRANTIES, EXPRESS AND IMPLIED, INCLUDING THE WARRANTIES OF MERCHANTABILITY AND FITNESS FOR A PARTICULAR PURPOSE. THE WARRANTY GIVEN ON THIS PAGE SHALL BE STRICTLY LIMITED IN DURATION TO THREE YEARS FROM THE DATE OF ORIGINAL PURCHASE FROM AN AUTHORIZED MACKIE DEALER. UPON EXPIRATION OF THE APPLICABLE WARRANTY PERIOD, LOUD TECHNOLOGIES INC. SHALL HAVE NO FURTHER WARRANTY OBLIGATION OF ANY KIND. LOUD TECHNOLOGIES INC. SHALL NOT BE LIABLE FOR ANY INCIDENTAL, SPECIAL, OR CONSEQUENTIAL DAMAGES THAT MAY RESULT FROM ANY DEFECT IN THE MACKIE PRODUCT OR ANY WARRANTY CLAIM. Some states do not allow exclusion or limitation of incidental, special, or consequential damages or a limitation on how long warranties last, so some of the above limitations and exclusions may not apply to you. This warranty provides specific legal rights and you may have other rights which vary from state to state.

MACKIE®

16220 Wood-Red Road NE • Woodinville, WA 98072 • USA

United States and Canada: 800.898.3211

Europe, Asia, Central and South America: 425.487.4333

Middle East and Africa: 31.20.654.4000

Fax: 425.487.4337 • www.mackie.com

E-mail: sales@mackie.com