



JAY R. SMITH CO.

PLUMBING & DRAINAGE PRODUCTS

959 Alness Street, North York, Ontario M3J 2J1
 TEL: (416) 736-9610 FAX: (416) 736-3789

LOCATION

DRAWING NUMBER
S9340-CAN

SIZE
A

SCALE:
NONE

DATE:
3-5-08

APPROVED BY:
CL

CHECKED BY:
CL

DRAWN BY:
RN

9340-CAN

FIGURE NUMBER

WE CAN ASSUME NO RESPONSIBILITY FOR USE OF SUPERSEDED OR VOID DATA

DIMENSIONS ARE SUBJECT TO MANUFACTURERS TOLERANCE AND CHANGE WITHOUT NOTICE

SPECIAL PURPOSE ISOLATED FLOOR DRAIN

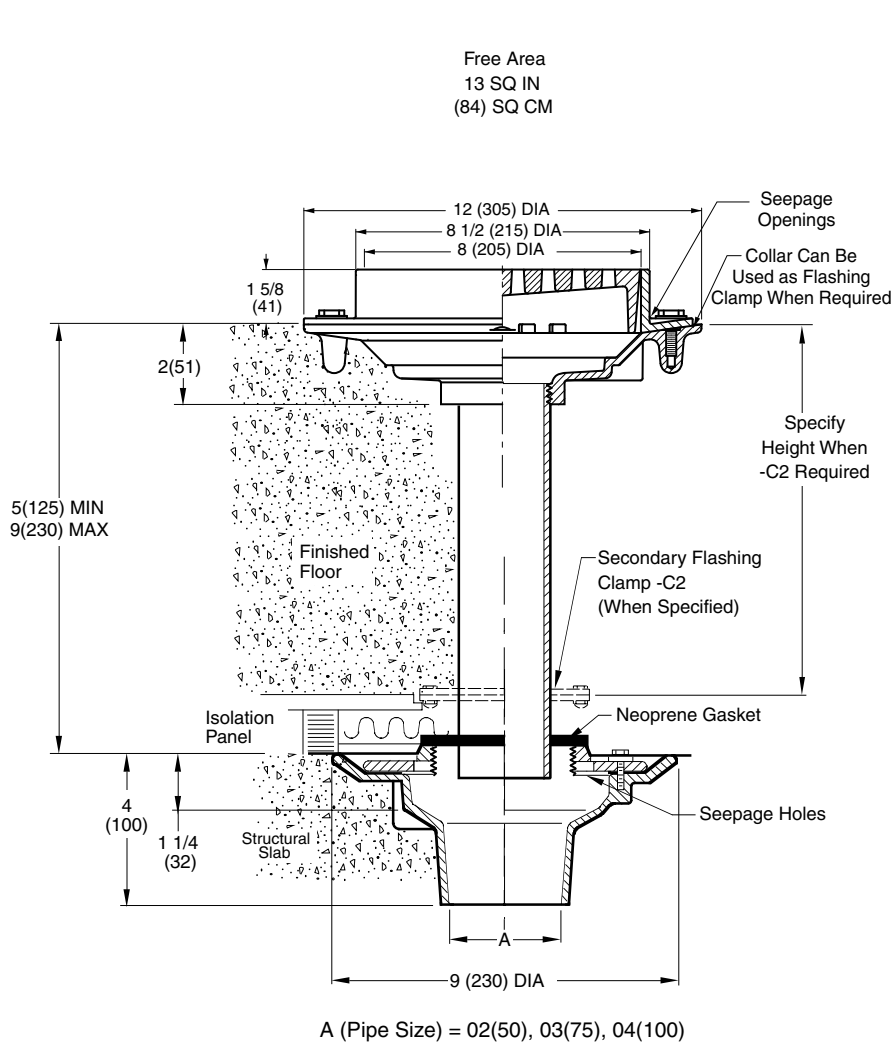

UPPER BODY

REGULARLY FURNISHED:
 Duco Cast Iron Body and Flashing
 Collar with Cast Iron Tractor Grate.

OPTIONAL MATERIALS:

- Nickel Bronze Top -NB
- Galvanized Body -G
- Polished Bronze Top -PB

VARIATIONS:

- Sediment Bucket -B

△Collar can be used as flashing device when required

Fig. 9340Y-CAN . . . NO-HUB OUTLET

LOWER BODY

REGULARLY FURNISHED:
 All Duco Cast Iron Lower Body and
 Flashing Collar, Adjustment Nipple
 and Upper Body, neoprene Isolation
 Gasket.

VARIATIONS:

- Trap Primer Connection -P050

REV.	DATE	DESCRIPTION	BY	CKD. BY

WEIGHT
POUNDS

VOLUME
CUBIC FEET

FIGURE NUMBER

9340-CAN