

WSF MUKILTEO TEST PILE PROJECT

**UNDERWATER SOUND LEVELS
ASSOCIATED WITH DRIVING STEEL
AND CONCRETE PILES NEAR THE
MUKILTEO FERRY TERMINAL**

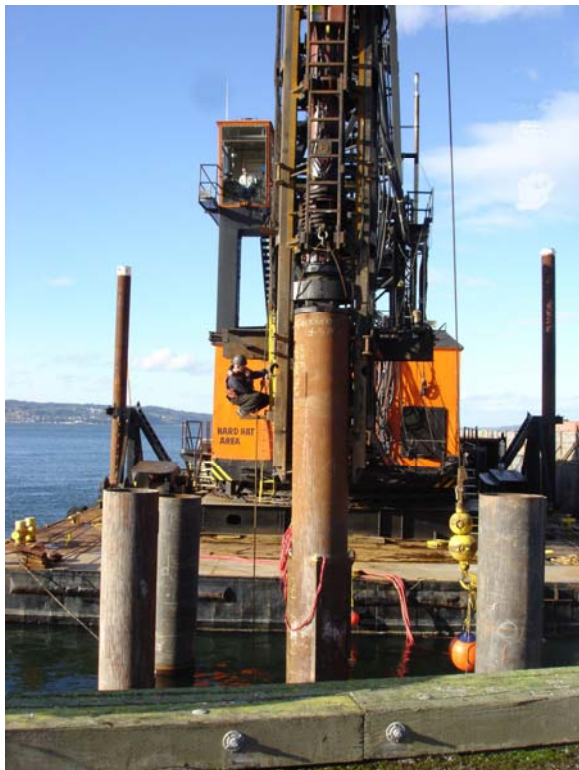

*Prepared by:
Jim Laughlin
Washington State Department of
Transportation
Office of Air Quality and Noise
15700 Dayton Avenue North, P.O. Box
330310
Seattle, WA 98133-9710*

March 2007

Table of Contents

List of Tables	i
List of Figures	ii
<i>Executive Summary</i>	<i>1</i>
<i>Introduction</i>	<i>3</i>
Project Description	3
<i>Underwater Sound Levels</i>	<i>6</i>
Characteristics of Underwater Sound	6
<i>Methodology</i>	<i>8</i>
Bubble Curtain Design	10
Temporary Noise Attenuation Pile (TNAP) Design	11
<i>Results</i>	<i>16</i>
Underwater Sound Levels	16
Airborne Noise Measurements	39
Biological Observations	49
<i>Conclusions</i>	<i>53</i>
<i>References</i>	<i>54</i>
<i>Appendix A– Steel Pile Waveform Analysis Figures</i>	<i>55</i>
Pile R4 – TNAP1 (Hollow Walled Casing)	55
Pile R3 – TNAP2 (Foam Lined Steel Casing)	58
Pile R1 – TNAP2	59
Pile T2 – Bubble Curtain	60
<i>Appendix B– Concrete Pile Waveform Analysis Figures</i>	<i>62</i>
Pile T1 – Octagonal Concrete Pile (With 12-Inch Wood Pile Cap)	62
Pile T3 – 36-Inch Hollow Concrete Pile (With 12-Inch Wood Pile Cap)	63
Pile T4 – 36-Inch Hollow Concrete Pile (With 12-Inch Wood Pile Cap)	64

LIST OF TABLES

Table 1: Summary Table of Monitoring Results.	2
Table 2: Summary of Underwater Sound Levels for the Mukilteo Test Pile Project, Steel Piles, Midwater.	19
Table 3: Summary of Overall Average Underwater Sound Levels for the Mukilteo Test Pile Project, Steel Piles, Midwater	20
Table 4: Comparison of Additive Bubble Curtain Ring Usage Against the Bubbles Off Condition.	29
Table 5: Summary of Underwater Sound Levels for the Mukilteo Test Pile Project, Concrete Piles, Midwater	33
Table 6: FHWA Noise Abatement Criteria	41
Table 7: Summary of Airborne Sound Levels for the Mukilteo Test Pile Project, Steel and Concrete Piles, on a Boat, 300 feet from the pile.	44
Table 8: Summary of Airborne Sound Levels for the Mukilteo Test Pile Project, Steel and Concrete Piles, on Top of Wall, 300 Feet from Pile.	46

LIST OF FIGURES

Figure 1: Location of test pile project northeast of the ferry terminal and just northwest of the fuel pier. _____	4
Figure 2: Location of piles relative to the bottom topography. The sediment is a mixture of sand and silt. _____	5
Figure 3: Underwater Sound Level Measurement Equipment _____	8
Figure 4: Diagram of hydrophone deployment at the monitoring locations. _____	9
Figure 5: Diagram of the bubble curtain ring system used for this project and the bubble curtain hole spacing pattern. _____	10
Figure 6: Photograph of the bubble curtain prior to deployment around the pile. _____	11
Figure 7: Double Walled TNAP Schematics. _____	12
Figure 8: Photograph of the Hollow Walled TNAP on the left. _____	13
Figure 9: Schematic of the Foam Walled TNAP. _____	14
Figure 10: Photograph of the Foam Walled TNAP on the right side in upper photo with a close-up of the foam lining and perforated steel mesh on the inside (bottom photo). _____	15
Figure 11: Waveforms and frequency spectral analysis for pile R4 using TNAP1. _____	18
Figure 12: Waveforms and frequency spectral analysis for pile R2 using a bubble curtain. _____	22
Figure 13: Waveforms and frequency spectral analysis for pile R3 using TNAP2. _____	24
Figure 14: Waveforms and frequency spectral analysis for pile R1 using TNAP2. _____	26
Figure 15: Waveforms and frequency spectral analysis for pile T2 using a bubble curtain. _____	28
Figure 16: Pile T2 Pile Strike Indicating Seismic Reflections. _____	30
Figure 17: Photograph of one of four previously used 4-inch thick plywood stacked disks that formed the wood pile cap for the concrete piles. _____	31
Figure 18: Waveforms and frequency spectral analysis for pile T1, a solid octagonal concrete pile with a 12-inch wood cap. _____	32
Figure 19: Waveforms and frequency spectral analysis for pile T3, a hollow concrete pile with a 12-inch wood cap. _____	35
Figure 20: Waveforms and frequency spectral analysis for pile T3, a hollow concrete pile with a 12-inch wood cap. _____	36
Figure 21: Waveforms and frequency spectral analysis for pile T4, a hollow concrete pile with a 12-inch wood cap. _____	38
Figure 22: Airborne monitoring Locations. _____	43
Figure 23: Typical plot of L_{max} , L_{95} , and L_{eq} for all pile strikes measured at the offshore site in a small boat for pile T4. _____	45
Figure 24: Typical plot of L_{max} , L_{95} , and L_{eq} for all pile strikes measured at the wall for pile T4. _____	46
Figure 25: Typical plot of L_{max} , L_{95} , and L_{eq} for all pile strikes measured at the eagles nest site for pile T4. _____	47
Figure 26: Plot of airborne average L_{max} sound levels over distance for pile strikes at Mukilteo, Washington. _____	49
Figure 27: Photograph of two of the three striped pile perch that were killed as a result of driving steel piles without mitigation near the Mukilteo fuel pier. _____	50
Figure 28: Waveform Analysis of Pile R4 Sound Pressure Levels with Temporary Noise Attenuation Pile 1 (TNAP1), Midwater. _____	55
Figure 29: Waveform Analysis of Pile R4 Sound Pressure Levels with Temporary Noise Attenuation Pile 1 (TNAP1), Midwater _____	56
Figure 30: Waveform Analysis of Pile R2 Sound Pressure Levels with Bubble Curtain On (b) and Off (a), Midwater. _____	57
Figure 31: Waveform Analysis of Pile R3 Sound Pressure Levels with Temporary Noise Attenuation Pile 2 (TNAP2), Midwater. _____	58
Figure 32: Waveform Analysis of Pile R1 Sound Pressure Levels with TNAP2, Midwater. _____	59
Figure 33: Waveform Analysis of Pile T2 Sound Pressure Levels with Bubble Curtain Off (a), Bottom Ring On Only (b), and Both Rings On (c), Midwater. _____	61
Figure 34: Waveform Analysis of Pile T1 Sound Pressure Levels of Octagonal Concrete Pile with 12-inch Wood Cap, Midwater. _____	62
Figure 35: Waveform Analysis of Pile Number T3 Sound Pressure Levels of Hollow Concrete Pile with 12-inch Wood Cap, Midwater. _____	63
Figure 36: Waveform Analysis of Pile Number T4 Sound Pressure Levels of Hollow Concrete Pile with 12-inch Wood Cap, Midwater. _____	64

EXECUTIVE SUMMARY

This technical report describes the data collected during pile driving efforts for the Mukilteo Test Pile Project just northeast of the Mukilteo Ferry Terminal during the months of November and December 2006 with a retest of pile R4 in February of 2007. A total of 8 test piles were driven: Five 36-inch diameter steel piles with 1-inch walls, two 36-inch hollow concrete piles, and one 24-inch solid octagonal concrete pile were monitored at slightly different water depths (tide dependent) at the Mukilteo Fuel Pier facility. Table 1 summarizes the results for each pile monitored. Two new sound mitigation devices were tested against the standard bubble curtain as part of this project for their sound reduction properties.

- A hollow walled steel pile casing around the pile being driven and,
- A steel casing with a 2-inch closed cell foam liner inside.

The bubble curtain was tested with the bubbles on and with the bubbles off during the pile driving events. The concrete piles used a 12-inch wood pile cap which has previously been shown to have sound reduction capabilities up to 24 dB (Laughlin, 2006).

Ambient sound levels measured 10 meters from the test piles in 21 feet of water ranged between 136 dBrms to 137 dBrms with construction equipment running. The bubble curtain achieved the greatest sound attenuation of the three sound mitigation devices. The sound reduction achieved with the bubble curtain ranged between 19 and 23 dB depending on which pile was used as the unmitigated (baseline) pile, R2 or T2.

Additionally, airborne sound measurements were made at three locations.

- On a boat 300 feet from the pile being driven
- Onshore 300 feet from the pile being driven
- Onshore approximately 2,000 feet from the pile being driven below an eagles nest.

A consultant, Jasco Ltd. was hired to deploy underwater noise monitoring devices at different distances from the piles to determine the rate of transmission loss over distance. These data will be discussed in a separate report from Jasco Ltd.

Table 1: Summary Table of Monitoring Results.

Pile	Date	Mitigation Type	Peak (dB)	RMS (dB)	Number of Strikes	Average Reduction (dB) ^{3,6}	SEL (dB)
Steel Piles							
R4	11/16/06	TNAP1 ¹	203 ⁴	189	73	4 (R2) 9(T2)	175
	2/19/07	TNAP1 - Retest	195	179	34	12 (R2) 17(T2)	168
R2	11/16/06	Bubbles Off	206 ⁴	195	24	-	180
		Bubbles On	187 ⁴	172	227	19 (R2) 24 (T2)	160
R3	11/16/06	TNAP2 ²	188 ⁴	174	91	19 (R2) 23 (T2)	163
R1	11/16/06	TNAP2 ²	191 ⁴	178	152	15 (R2) 19 (T2)	166
T2	11/16/06	Bubbles On	188	172	86	22 (T2) 22 (R2)	162
		Bubbles Off	214 ⁴	201	29	-	184
Concrete Piles							
T1 (solid)	11/20/06	None ⁵	184	170	184	-	159
T3 (hollow)	12/5/06	None ⁵	193	183	204	-	167
T4 (hollow)	12/5/06	None ⁵	194	181	62	-	167
T4 (hollow) (new wood cap)			196 ⁴	186	193	-	170

¹ – TNAP1 (Temporary Noise Attenuation Pile) is a hollow walled steel pile casing placed around the pile being driven. Hollow cavity accidentally filled with water during installation thus substantially reducing it's potential effectiveness. The TNAP1 was repaired and retested on 2/19/07.

² – TNAP2 is a steel pile with a 2-inch thick closed cell foam lining on the inside of the pile and a perforated metal screen on the inside of the foam.

³ – Average reduction is based on the baseline pile for the piles where the TNAP was tested. Otherwise the average reduction is derived from the same pile but the bubble curtain on is compared to the bubble curtain off.

⁴ – Peak represents underpressure.

⁵ – A 12-inch wood pile cap was used on all the concrete piles. No measurements were taken without the caps but based on a previous study testing various pile cap materials wood pile caps can reduce sound levels substantially (up to 24 dB on 12-inch steel piles, Laughlin, 2006).

⁶ – Sound levels of the different mitigation strategies for each pile was compared to two separate piles (R2 and T2 in parentheses) which were measured without mitigation (baseline).

INTRODUCTION

This technical report presents results of underwater sound levels measured during the driving of five 36-inch steel piles, two 36-inch hollow concrete piles, and one 24-inch solid octagonal concrete pile at the Mukilteo Test Pile Project in November and December 2006 (Contract Number: 007155).

The eight piles were monitored at different water depths dependent on location and tidal flux. For comparison a bubble curtain was also tested with on/off cycles during each pile driving event where it was used. Figure 1 shows project area and Figure 2 shows the locations of monitored piles.

Additionally, airborne sound levels were made at three separate locations. 300 feet offshore, 300 feet onshore, and approximately 2,000 onshore below an eagles nest to determine transmission loss over land and water.

PROJECT DESCRIPTION

The piles were driven to determine if alternate construction methods and materials are feasible. The Test Pile Project addressed two aspects of ferry terminal design:

- Pile Material – Hollow concrete piles rather than hollow steel piles
- Temporary Noise Attenuation Piles – Hollow walled steel casing (TNAP1) and foam lined steel casing (TNAP2).

The project location is northeast of the existing Mukilteo Ferry Terminal near the Fuel Pier facility (Figure 1). Water depths at the monitoring locations varied from 24 feet to 42 feet deep. There was an approximate 5 foot tidal flux over a 6 hour period. No substantial currents were observed in the area monitored.



Figure 1: Location of test pile project northeast of the ferry terminal and just northwest of the fuel pier.

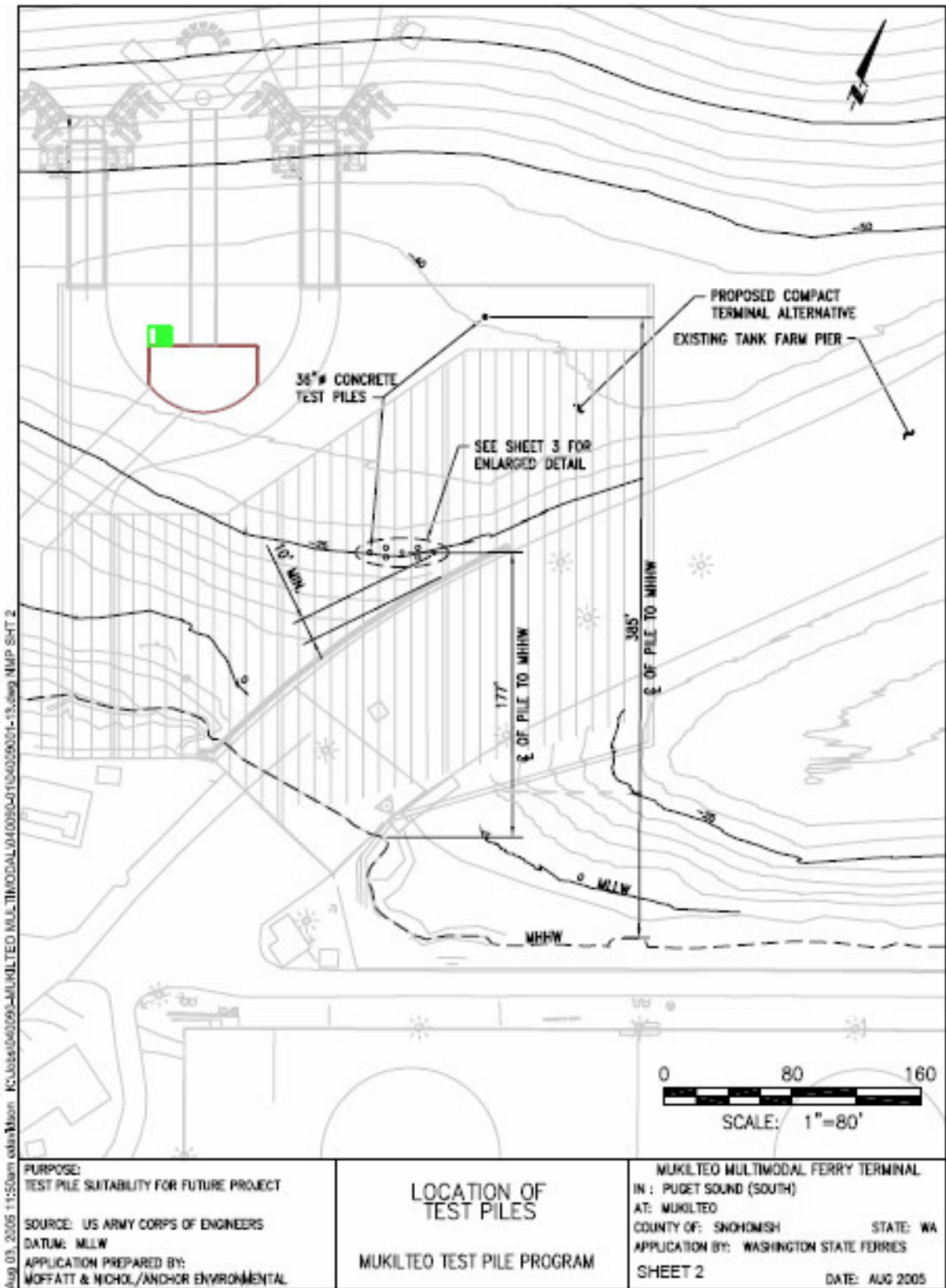

Figure 2: Location of piles relative to the bottom topography. The sediment is a mixture of sand and silt.

UNDERWATER SOUND LEVELS

CHARACTERISTICS OF UNDERWATER SOUND

Several descriptors are used to describe underwater noise impacts. Two common descriptors are the instantaneous peak sound pressure level (SPL) and the Root Mean Square (RMS) pressure level during the impulse, which are sometimes referred to as the SPL and RMS level respectively. The peak pressure is the instantaneous maximum or minimum overpressure observed during each pulse and can be presented in Pascals (Pa) or decibels (dB) referenced to a pressure of 1 micropascal (μPa). Since water and air are two distinctly different media, a different sound pressure level reference pressure is used for each. In water, the most commonly used reference pressure is 1 μPa whereas the reference pressure for air is 20 μPa . The equation to calculate the sound pressure level is:

$$\text{Sound Pressure Level (SPL)} = 20 \log (p/p_{\text{ref}}), \text{ where } p_{\text{ref}} \text{ is the reference pressure (i.e., } 1 \mu\text{Pa for water)}$$

The RMS level is the square root of the energy divided by the impulse duration. This level, presented in dB re: 1 μPa , is the mean square pressure level of the pulse. It has been used by National Marine Fisheries Service (NMFS) in criteria for judging impacts to marine mammals from underwater impulse-type sounds. The majority of literature uses peak sound pressures to evaluate barotraumas injuries to fish. Except where otherwise noted, sound levels reported in this report are expressed in dB re: 1 μPa .

Rise time is another descriptor used in waveform analysis to describe the characteristics of underwater impulses. Rise time is the time in microseconds (ms) it takes the waveform to go from background levels to absolute peak level.

Sound Exposure Level (SEL), frequently used for human noise exposures, has recently been suggested as a possible metric to quantify impacts to fish (Hastings and Popper 2005). Dr. Hastings has abandoned her previous recommended 180 dB_{peak} and 150 dB_{rms} thresholds for injury and harm to fish (Hastings, 2002). In 2006 Popper et al. proposed a 187 dB_{SEL} along with a 208 dB_{peak} as the new barotrauma dual criteria for fish. SEL is often used as a metric for a single acoustic event and is often used as an indication of the energy dose. SEL is calculated by summing the cumulative pressure squared (p^2), integrating over time, and normalizing to the time over which 90% of the pulse energy occurs. The SEL accounts for both negative and positive pressures because p^2 is positive for both and thus both are treated equally in the cumulative sum of p^2 (Hastings and Popper, 2005). The units for SEL are dB re: 1 micropascal²-sec.

Popper et al. (2006) recommend a dual criterion of 208 dB re: 1 microPa (peak) and 187 dB re: 1 microPa²•s as interim guidance to protect fish from physical injury and mortality for a single pile driving impact. One of the reasons dual criteria (single peak pressure and SEL) have been suggested is because the relationship between the SEL and the peak pressure is not consistent between pile strikes for a given pile driving operation or between different types of piles. The reason that a dual criteria was recommended was to provide protection of fish from physical injury from barotraumas by limiting the SPL threshold to 208 peak dB, and from physical injury to their hearing by limiting the SEL threshold to 187 dB_{SEL} .

Popper and Carlson (Pers. Comm., 2006) provided the calculations below which, in essence, compare the 187 dB SEL single strike criterion presented in the Popper et al., 2006 white paper to the 220 dB equivalent SEL that caused a gourami to become unconscious after 10 minutes of exposure (presented in Appendix B of Hastings and Popper 2005.) 220 dB SEL is therefore a reasonable and conservative threshold for injury. The calculations show the number of

successive single strikes with an SEL of 187 dB that would be needed to result in a cumulative SEL of 220 dB assuming no recovery between pile strikes.

$$\text{Cumulative SEL} = 10 \text{ Log (\# of strikes)} + \text{Single Strike SEL}$$

$$220 \text{ dB} = 10 \text{ Log (\# of strikes)} + 187 \text{ dB re: } 1 \text{ microPa}^2 \bullet \text{s}$$

$$\# \text{ of strikes} = 10^{(220-187)/10}$$

$$\# \text{ of strikes} = 1,995$$

The calculations above indicate that 1,995 successive pile strikes, each with an SEL of 187 dB, would be needed to result in a cumulative SEL of 220 dB. WSDOT data indicates that for most of our piles the number of strikes average around 200 strikes per pile, often with breaks during the drive and inbetween piles, with a total of about 400 strikes per day assuming a maximum of two piles per day.

Some recovery of the tissue will take place during the interval between strikes that is not taken into account, so this approach should conservatively estimate effects to listed species.

METHODOLOGY

Underwater sound levels were measured using one Reson TC 4013 hydrophone. The hydrophone was positioned at mid-water level. The hydrophone was located at a distance of 10 meters (33 feet) from the pile being monitored. The measurement system includes a Brüel and Kjær Nexus type 2692 4-channel signal conditioner, which kept the high underwater sound levels within the dynamic range of the signal analyzer (Figure 3). The output of the Nexus signal conditioner is received by a Dactron Photon 4-channel signal spectrum analyzer that is attached to an Itronix GoBook II laptop computer.

The waveform of the pile strikes along with the number of strikes, overpressure minimum and maximum, absolute peak values, and RMS sound levels, integrated over 90% of the duration of the pulse, were captured and stored on the laptop hard drive for subsequent signal analysis. The system and software calibration is checked annually against a NIST traceable standard.

The operation of the hydrophone was checked daily in the field using a GRAS type 42AC high-level pistonphone with a hydrophone adaptor. The pistonphone signal was 146 dB re: 1 μ Pa. The pistonphone signal levels produced by the pistonphone and measured by the measurement system were within 1 dB and the operation of the system was judged acceptable over the study period. A photograph of the system and its components are shown in Figure 4.



Figure 3: Underwater Sound Level Measurement Equipment

Signal analysis software provided with the Photon was set at a sampling rate of one sample every 41.7 μ s (9,500 Hz). This sampling rate is more than sufficient for the bandwidth of interest for

underwater pile driving impact sound and gives sufficient resolution to catch the peaks and other relevant data. The anti-aliasing filter included in the Photon also allows the capture of the true peak.

Due to the high degree of variability between the absolute peaks for each pile strike, an average peak and RMS value is computed along with the standard deviation (s.d.) to give an indication of the amount of variation around the average for each pile.

A vibratory hammer was used to drive the piles initially. Then all piles were driven to bearing depth with a diesel hammer. The diesel impact driver was a DelMag D62 diesel hammer rated to a maximum of 164,620 foot pounds. This is the maximum energy output for the diesel hammer that can only be sustained for a few seconds at a time. Actual operation of the diesel hammer is more likely to be approximately 50% to 70% of this maximum energy for most pile installations.

The substrate consisted of a mix of sand and silt. Piles driven were five open-ended hollow steel piles, 36-inches in diameter with a one-inch wall thickness, one 24-inch concrete octagonal concrete pile, and two 36-inch hollow concrete piles. All measurements were made 33 feet from the pile, at mid-water depth.

The location of the hydrophone is determined by allowing a clear line of sight between the pile and the hydrophone, with no other structures nearby. The distance from the pile to the hydrophone location was measured using a Bushnell Yardage Pro rangefinder. The hydrophone was attached to a weighted nylon cord anchored with a five-pound weight. The cord and hydrophone cables were attached to a surface float at 33 feet (10 meters) from the pile (Figure 4) for monitoring piles.

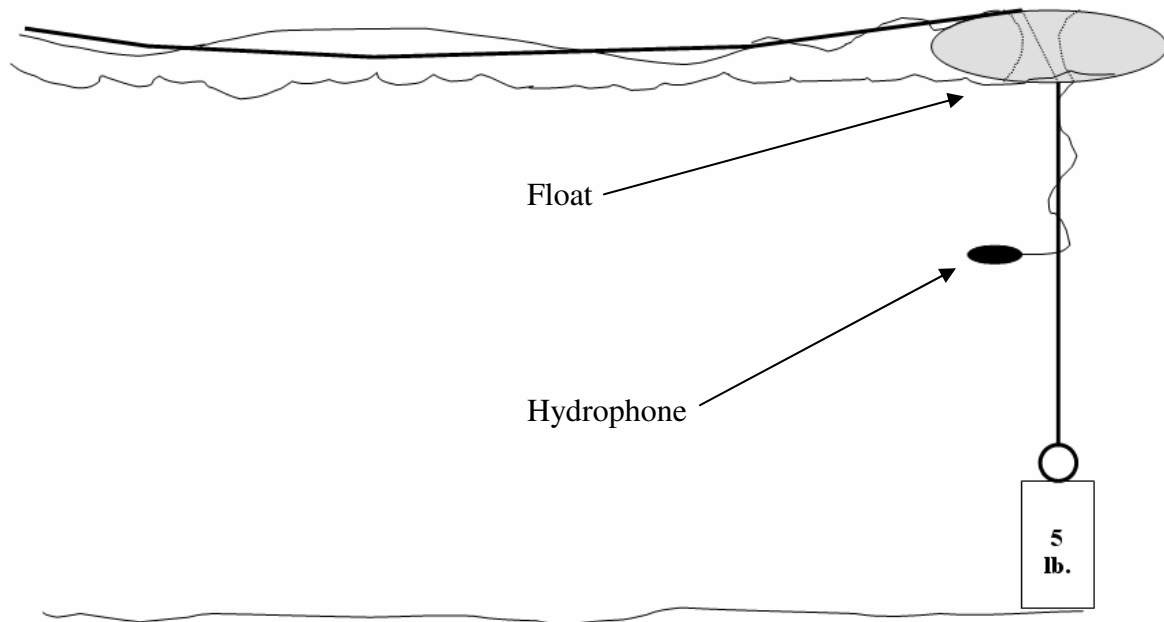

Figure 4: Diagram of hydrophone deployment at the monitoring locations.

BUBBLE CURTAIN DESIGN

The final bubble curtain design that was used by the contractor for the Mukilteo Test Pile Project is similar to the bubble curtain used at the Friday Harbor Ferry Terminal Project in 2005 (Figures 5 and 6). The air flow rate through the bubble curtain is 400 cfm at 75 psi. The major difference between these bubble curtains is that the Mukilteo bubble curtain (below) had no projections on the bottom ring to prevent it from seating itself flat on the bottom.

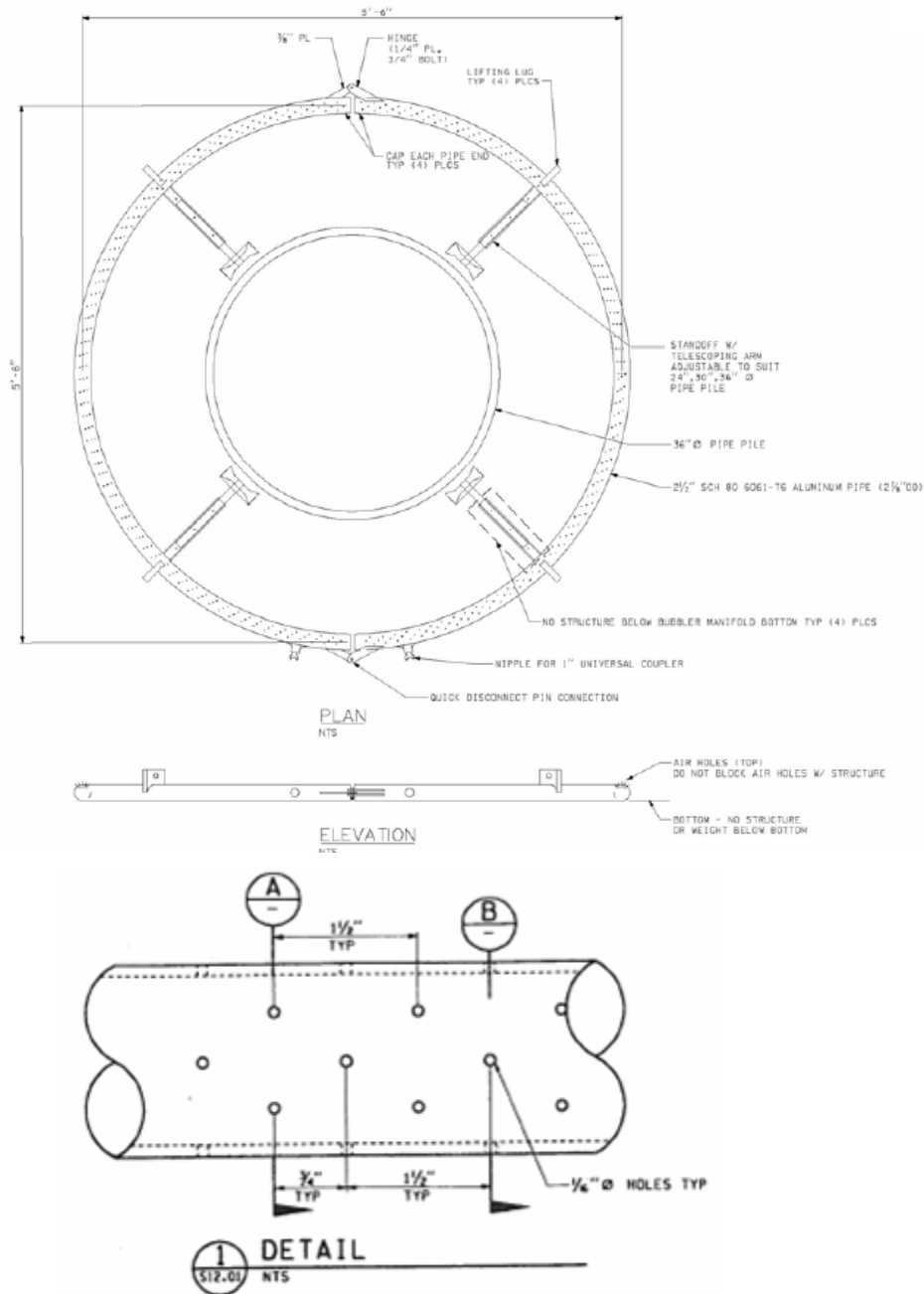

Figure 5: Diagram of the bubble curtain ring system used for this project and the bubble curtain hole spacing pattern.



Figure 6: Photograph of the bubble curtain prior to deployment around the pile.

TEMPORARY NOISE ATTENUATION PILE (TNAP) DESIGN

Two new Temporary Noise Attenuation Pile (TNAP) devices were tested as a part of this test pile project. The first TNAP tested (TNAP1) is a hollow steel pile casing with a 2-inch air filled hollow wall (Figures 7 and 8). The TNAP is placed around the pile being driven from the sediment surface to a few feet above the surface waterline. During initial testing of TNAP1 it was determined that it was not providing an effective amount of attenuation. Later it was discovered that the hollow wall had leaked and filled with water making TNAP1 ineffective.

The second TNAP (TNAP2) is a hollow steel pile casing with a 2-inch closed cell foam liner inside the pile (Figures 9 and 10). This TNAP was found to be almost as effective in mitigating sound levels as the bubble curtain for this location.

Figure 7: Double Walled TNAP Schematics.

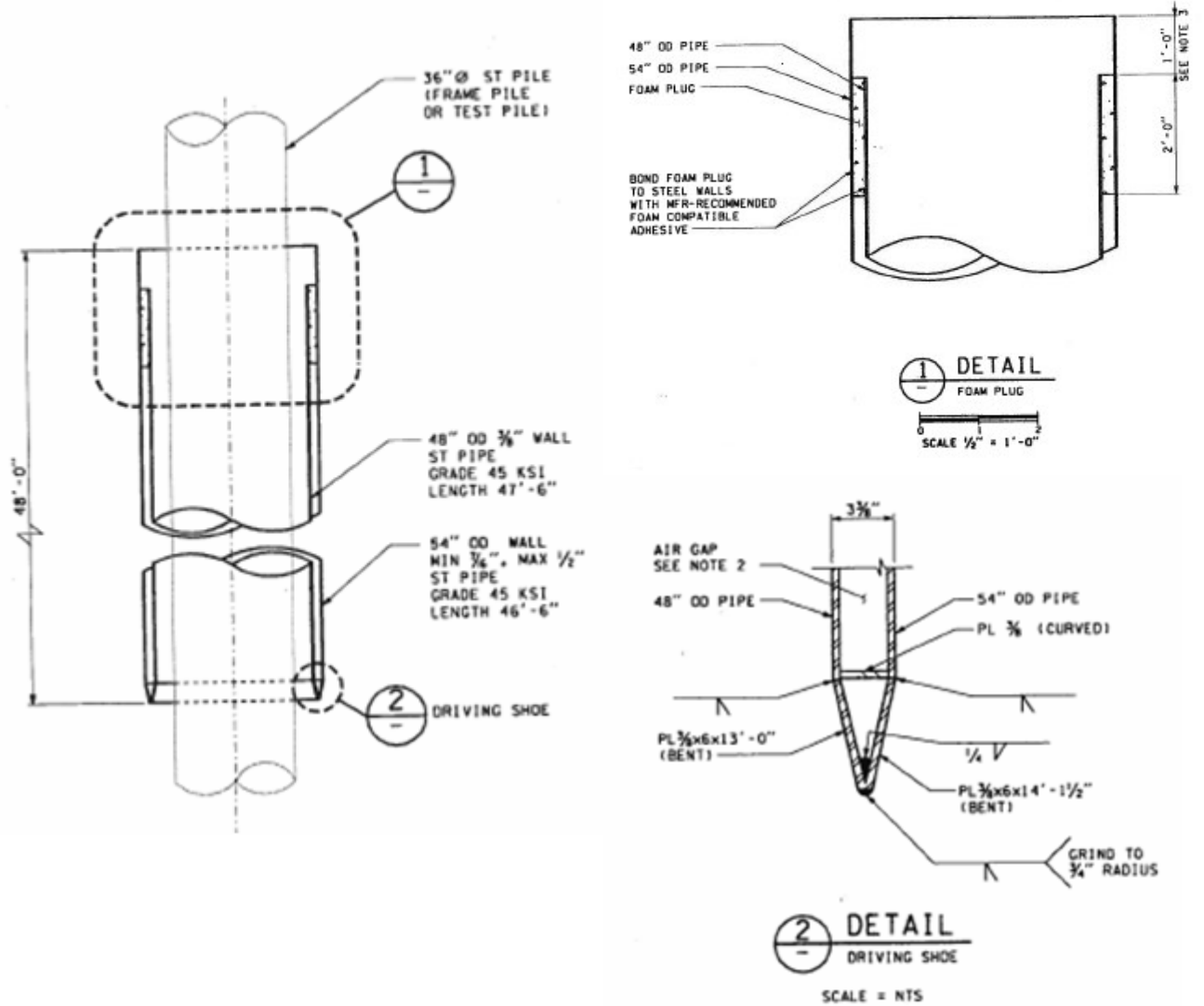
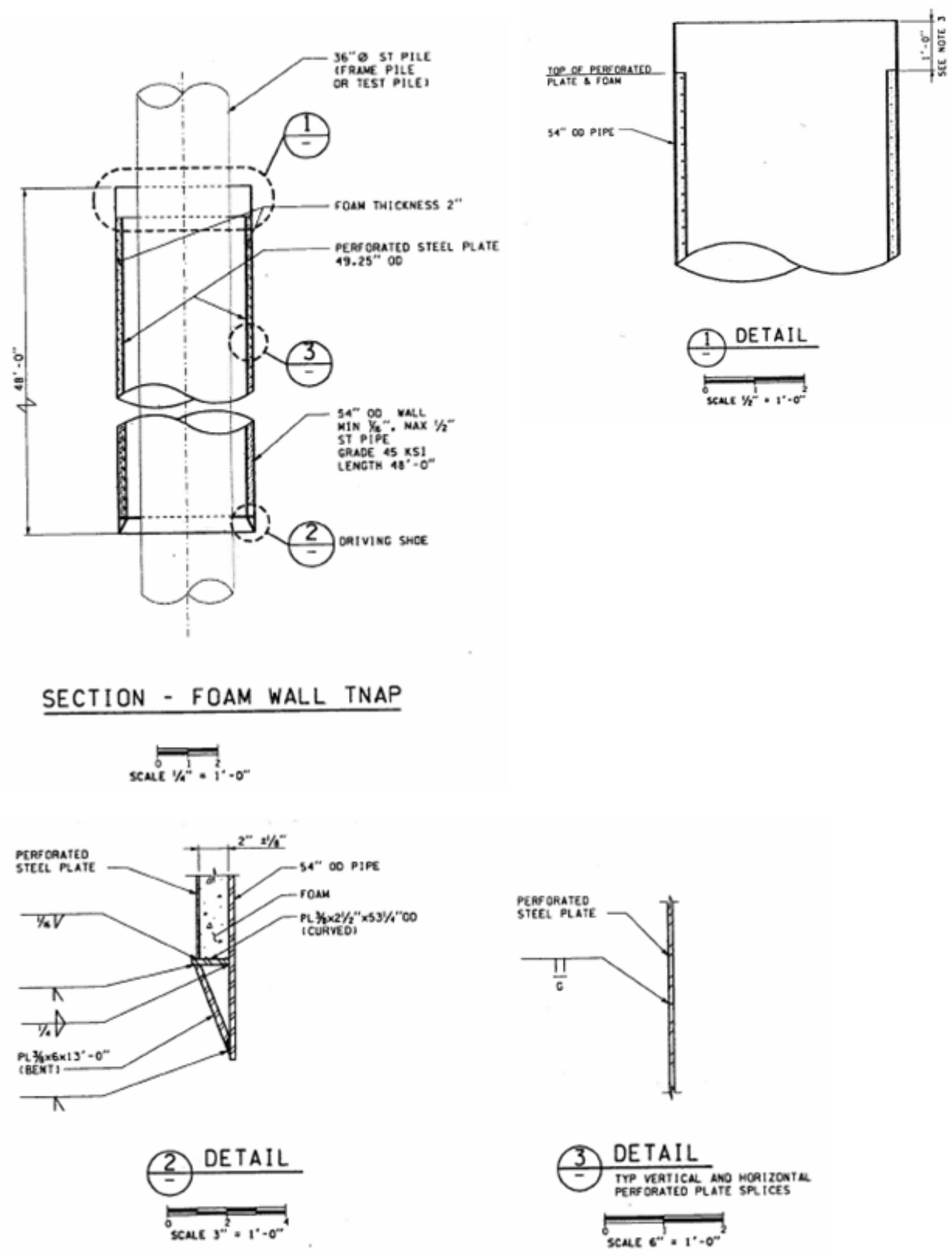



Figure 8: Photograph of the Hollow Walled TNAP on the left.

Figure 9: Schematic of the Foam Walled TNAP.



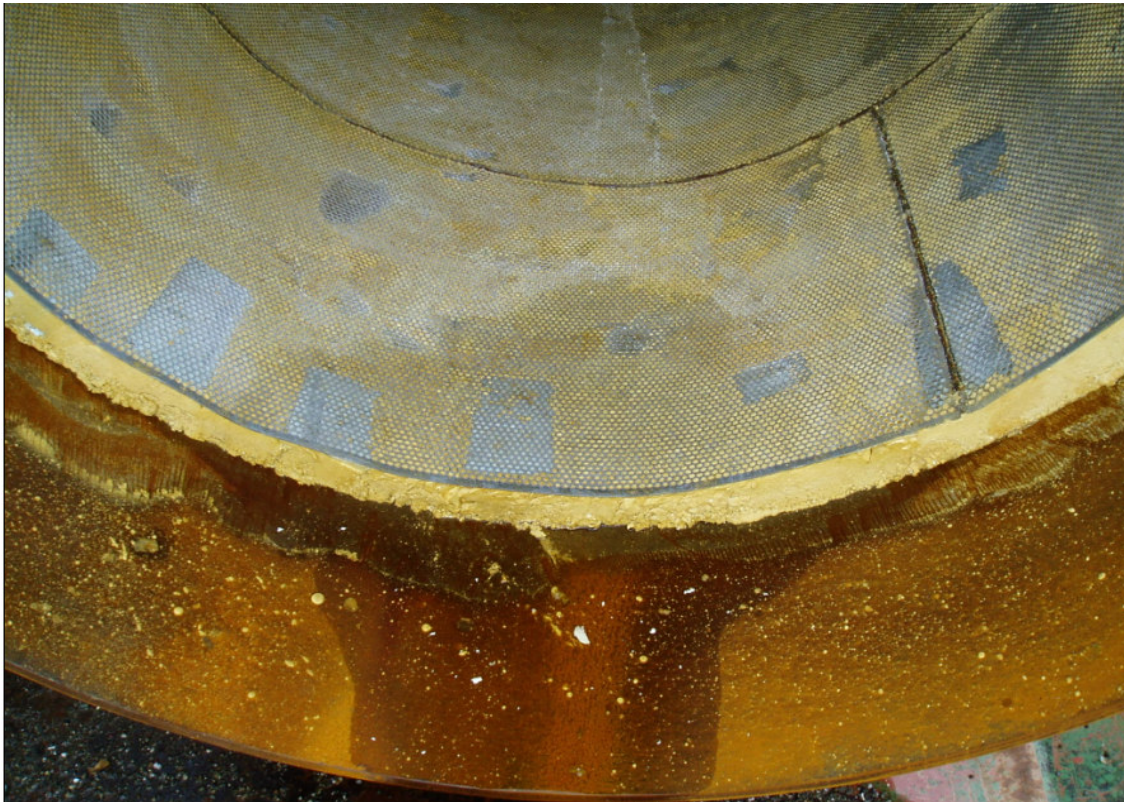

Figure 10: Photograph of the Foam Walled TNAP on the right side in upper photo with a close-up of the foam lining and perforated steel mesh on the inside (bottom photo).

RESULTS

UNDERWATER SOUND LEVELS

In the waveform figures that follow, the axes all have the same scale. This will facilitate visual comparisons between piles and with and without mitigation. There are many interesting attributes of the waveforms of different piles and mitigation types that will become evident. A brief description of the piles and pile types that were tested are as follows:

Pile	Type	Attenuation
R4	Steel	Hollow Walled TNAP1
R2	Steel	Bubble Curtain
R3	Steel	Foam Lined TNAP2
R1	Steel	Foam Lined TNAP2
T2	Steel	Bubble Curtain
T1	Solid Octagonal Concrete	None
T3	Hollow Concrete	None
T4	Hollow Concrete	None

Steel Piles

PILE R4

Pile R4 was driven with a diesel hammer in a water depth of 24 feet and utilized the hollow walled Temporary Noise Attenuation Pile (TNAP1). Three shiner perch were killed during the initial driving of this pile. Then a bubble curtain was activated on the adjacent pile T2 and no further fish kills were observed. It was discovered after monitoring was completed that the TNAP1 hollow wall had leaked and filled with water rendering it ineffective. The sound levels for Pile R4 in Table 2 indicate that when compared to another similar pile without mitigation there was only a 4 to 9 decibel noise reduction. However, it is uncertain whether this sound reduction was the result of a partially functioning TNAP or the bubbles in the water column.

In Figure 11a the peak pile strike waveform with the ineffective TNAP1 is represented. When compared to the peak strike waveform for Pile R2 without mitigation (11b) there appears to be some decrease in the overall amplitude of the pile strike from using TNAP1, but not as much as expected.

In Figure 11d the narrow band frequencies of the peak pile strikes from Pile R4 and R2 are compared. In this spectral analysis there appears to be some suppression of the higher frequencies which would also correlate to the drop in amplitude of the peak strike seen in Figure 11a.

On February 19, 2007 the TNAP1 was repaired and was retested on Pile R4. Figure 11c indicates the peak pile strike waveform with the repaired TNAP1. When compared to the ineffective TNAP1 (Figure 11a) it can be seen that there was further reductions in sound levels with the repaired TNAP1.

In Figure 11e the narrow band frequencies of the peak pile strike from the ineffective and repaired TNAP1 are compared. It can be seen that there are further suppression of the higher frequencies which also correlates to the drop in amplitude of the peak pile strike seen in Figure 11c.

Table 2 indicates the results of monitoring for Pile R4. The highest absolute peak from the midwater hydrophone is 203 dB_{peak}. The highest midwater RMS is 189 dB_{RMS}. The highest midwater SEL for the peak strike was 175 dB_{SEL}. As can be seen in Appendix A Figure 28 the waveform analysis for Pile R4 indicates that there was a relatively short delay between the initial onset of the impulse and the absolute peak (rise time of 5.2 milliseconds). This is another indication that the TNAP was not working properly. 72% all of the peak values exceed 180 dB_{peak} and all strikes exceeded 150 dB_{RMS}.

The single strike SEL in Table 2 did not exceed the proposed interim dual criteria of 208 dB_{peak} and 187 dB_{SEL}. The calculated cumulative SEL for 73 pile strikes was 206 dB_{SEL} and did not exceed the proposed benchmark of 220 dB_{SEL}.

One juvenile shiner perch killed during driving of this pile floated to the surface less than 10 meters from the pile. Therefore, it is assumed that the perch were exposed to higher peak and SEL levels than were measured at 10 meters. It is likely that the peak and SEL values were much closer to or even higher than the dual interim criteria of 208 dB_{peak} and 187 dB_{SEL}.

Table 3 indicates the overall average sound levels for all steel piles tested using the bubble curtain (R2+T2) and all steel piles tested using TNAP2 (R3+R1). The overall peak and RMS sound levels were lower using the bubble curtain than they were using TNAP2. The sound reductions achieved using the bubble curtain were also higher than with TNAP2.

Figure 11: Waveforms and frequency spectral analysis for pile R4 using TNAP1.

a. Pile R4 with TNAP1

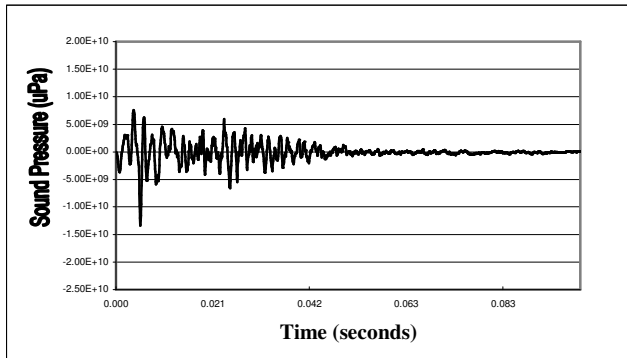

b. Pile R2 with No Mitigation

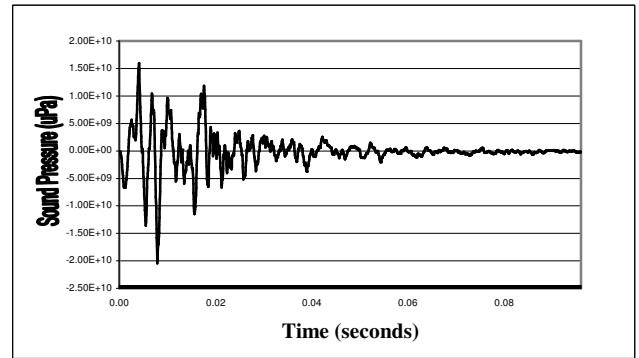

c. Pile R4 retested with repaired TNAP1

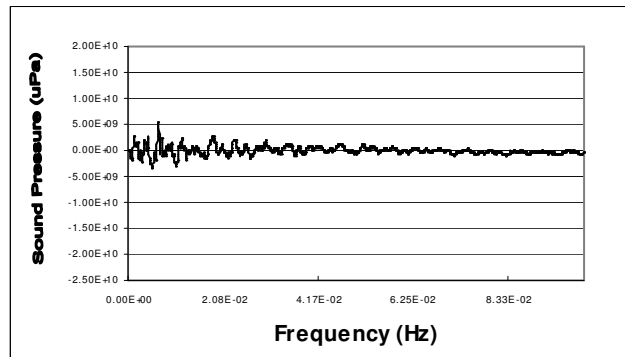

d. Pile R4 with TNAP1 Frequency Data Compared to Pile R2 with No Mitigation

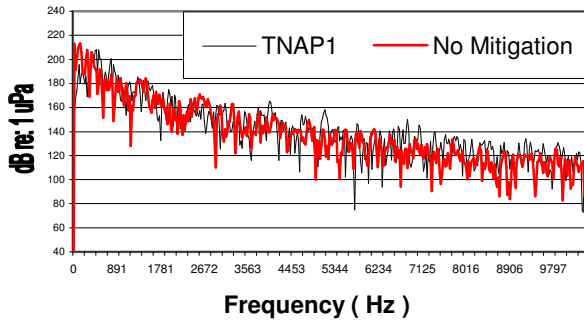

e. Pile R4 with repaired TNAP1 Frequency Data Compared to Pile R2 with No Mitigation

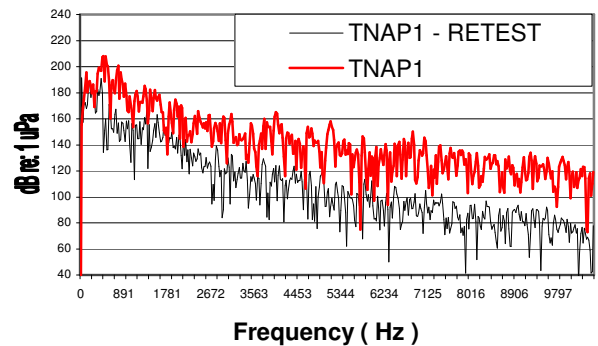

Table 2: Summary of Underwater Sound Levels for the Mukilteo Test Pile Project, Steel Piles, Midwater.

Pile	Date	Mitigation Type	Peak (dB)	RMS (dB)	Avg. RMS ± s.d. (Pascals)	Avg. dB _{RMS}	# of Strikes	Avg. Peak ± s.d. (Pascals)	Avg. dB _{peak}	Avg. Reduction (dB) ⁶	SEL (dB)	Rise Time (millesec.)	Cumulative SEL (dB) ⁷	% of Strikes Over 180 dB
R4	11/16/06	TNAP1 ¹	203 ⁴	189	1503±293	184	73	7727±1911	198	4 (R2) 9(T2)	175	5.2	206	72
	2/19/07	TNAP1-Retest	195	179	485±123	174	34	3021±1056	190	12 (R2) 17(T2)	168	6.7	202	94
R2	11/16/06	Bubbles Off	206 ⁴	195	2314±610	187	24	12390±5182	202	-	180	8.3	201	98
		Bubbles On	187 ⁴	172	261±29	168	227	1477±306	183	19 (R2) 24 (T2)	160	20.1	211	23
R3	11/16/06	TNAP2 ²	188 ⁴	174	341±59	171	91	1529±240	184	19 (R2) 23 (T2)	163	23.2	207	100
R1	11/16/06	TNAP2 ²	191 ⁴	178	586±78	175	152	2653±413	188	15 (R2) 19 (T2)	166	19.4	209	99
T2	11/16/06	Bubbles On	188	172	336±50	171	86	1733±349	185	22 (T2) 17 (R2)	162	19.3	206	95
		Bubbles Off	214 ⁴	201	3748±1575	191	29	22783±11058	207	-	184	17.2	202	100

¹ – TNAP1 (Temporary Noise Attenuation Pile) is a hollow walled steel pile casing placed around the pile being driven. The hollow cavity accidentally filled with water during installation thus substantially reducing it's potential effectiveness. The TNAP1 was repaired and retested on 2/19/07.

² – TNAP2 is a steel pile with a 2-inch thick closed cell foam lining on the inside of the pile and a perforated metal screen on the inside of the foam.

³ – Average reduction is based on the baseline pile for the piles where the TNAP was tested. Otherwise the average reduction is derived from the same pile but the bubble curtain on is compared to the bubble curtain off.

⁴ – Peak represents underpressure.

⁵ – A 12-inch wood pile cap was used on the concrete piles. Based on a previous study testing various pile cap materials wood pile caps can reduce sound levels substantially (up to 24 dB on 12-inch steel piles, Laughlin, 2006).

⁶ – Sound levels of the different mitigation strategies for each pile was compared to two separate piles (R2 and T2 in parentheses) which were measured without mitigation (baseline).

⁷ – Cumulative SEL benchmark is 220 dB_{SEL} based on 1,995 pile strikes. Formula for calculating cumulative SEL is $10\log_{10}(\#\text{strikes})+187\text{dB}_{\text{SEL}}$.

Table 3: Summary of Overall Average Underwater Sound Levels for the Mukilteo Test Pile Project, Steel Piles, Midwater

Pile	Date	Mitigation Type	Overall Avg. Peak ± s.d. (Pascals)	Overall Avg. dB_{peak}	Overall Avg. Reduction (dB)	Overall Avg. RMS ± s.d. (Pascals)	Overall Avg. dB_{RMS}
R2 + T2	11/16/06	Bubbles Off	12920±3996	202	-	2123±726	187
		Bubbles On	1560±321	184	18	284±67	169
R3 + R1	11/16/06	TNAP2	2670±357	189	13	496±133	174

PILE R2

Pile R2 was driven in water depth of 24 feet with a bubble curtain in place. While obtaining a baseline reading for an unattenuated pile, one juvenile shiner perch was killed. After the fish kill the contractor turned the bubble curtain on before pile driving began to scare away any fish that might be in the immediate area of the piles. Then the bubble curtain was turned off and pile driving started. After approximately 24 hammer strikes the bubble curtain was turned on for the remainder of the drive. No other fish were killed. This implies that if fish are removed from the near field area around the pile (within 10 meters around the pile) no mortality will occur. It also begs the question of whether the bubble curtain is actually providing sound attenuation that reduces injury to fish or simply scares them out of the kill zone.

Figure 12 clearly indicates the difference between the peak strike waveform without the bubble curtain (12a) and the peak strike waveform with the bubble curtain (12b) displayed using the same relative scale. This is a visual representation of a 19 to 24 peak decibel noise reduction that was calculated for the bubble curtain on this pile (Table 2).

In Figure 12c the narrow band frequencies of the peak pile strikes for the bubbles on and off conditions for Pile R2 are compared. In this spectral analysis there appears to be suppression of both the upper and lower frequencies which also correlates to the drop in amplitude of the peak strike seen in figure 12b and the higher sound reductions associated with the lower frequencies.

Table 2 indicates the highest absolute peak recorded for this pile was 206 dB_{peak} with the bubbles off and 187 dB_{peak} with the bubbles on. The highest RMS is with the bubbles on is 172 dB_{RMS} and 195 dB_{RMS} with the bubbles off. The highest SEL for the peak strike is 180 dB_{SEL} with the bubbles off and 160 dB_{SEL} with the bubbles on. 98% of the strikes with the bubbles off and 23% of the strikes with the bubbles on exceeded 180 dB_{peak} and all the strikes exceeded 150 dB_{RMS} with or without the bubble curtain. The average peak sound reductions achieved with the bubble curtain ranged between 19 and 24 dB depending on which pile without mitigation the bubble curtain results were compared to (Pile R2 or Pile T2).

The single strike SEL in Table 2 did not exceed the proposed interim dual criteria 208 dB_{peak} and 187 dB_{SEL}. The calculated cumulative SEL for a total of 251 pile strikes is 211 dB_{SEL} and did not exceed the proposed benchmark of 220 dB_{SEL}. This benchmark is a very conservative estimate of potential mortality or injury impacts for multiple pile strikes. The one shiner perch killed during driving of this pile floated to the surface less than 10 meters from the pile. Therefore, it is assumed that the perch was exposed to higher peak and SEL levels than were measured at 10 meters. It is likely that the peak and SEL levels were much closer to or even higher than the proposed dual interim criteria of 208 dB_{peak} and 187 dB_{SEL}.

Figure 12: Waveforms and frequency spectral analysis for pile R2 using a bubble curtain.

a. Pile R2 (No Mitigation)

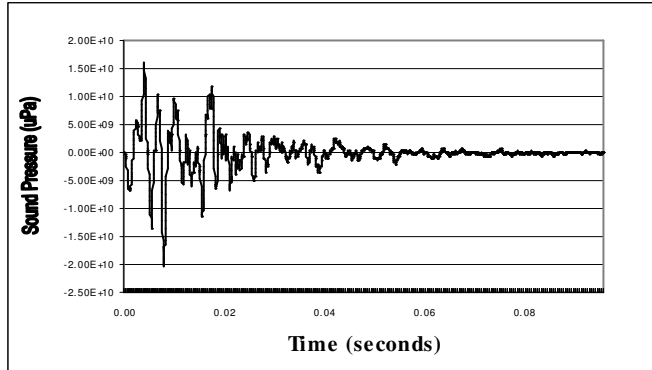

b. Pile R2 with Bubble Curtain

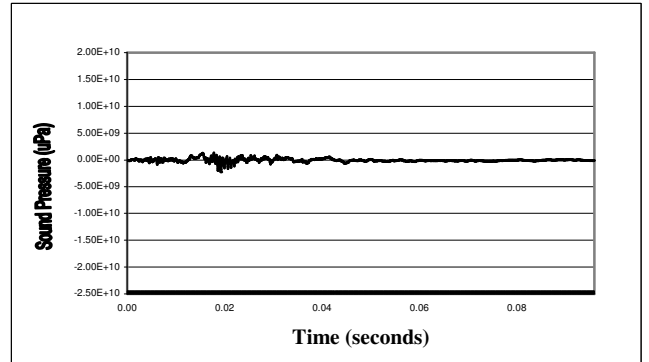

c. Pile R2 with Bubble Curtain Frequency Data Compared to without Bubble Curtain on the Same Pile

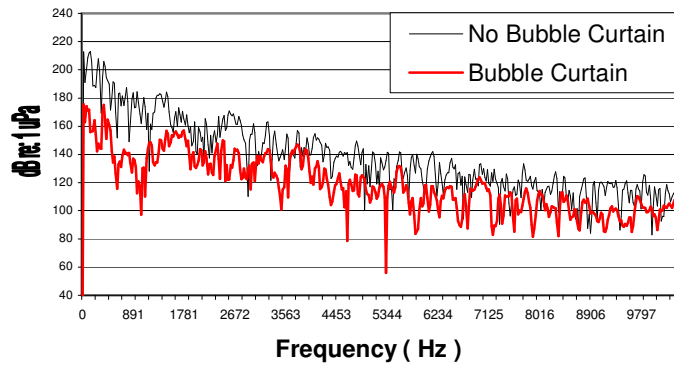

PILE R3

Pile R3 was driven in water depth of 25 feet utilizing the closed cell foam lined TNAP2. For this pile there was a concern about potential fish kills as we had seen using the previous TNAP1 on Pile R4 and because the bubble curtain rings diameter were not large enough to fit around the TNAP2 to serve as a backup mitigation device. Therefore, it was decided that the bubble curtain would be placed on pile R2 near pile R3 and turned on for approximately 2 minutes prior to driving the pile in an attempt to scare the fish away. The bubble curtain was turned off and pile driving was started.

Figure 13a indicates the difference between the peak strike waveform with TNAP2 in place compared to pile R2 without mitigation (13b). This is a visual representation of a 19 to 23 decibel noise reduction that was calculated for the bubble curtain on this pile (Table 2).

In Figure 13c the narrow band frequencies of the peak pile strikes for the TNAP2 and no mitigation (R2) are compared. In this spectral analysis there appears to be suppression of both the upper and lower frequencies which also correlates to the drop in amplitude of the peak strike seen in figure 8a and the higher sound reductions associated with the lower frequencies.

Table 2 indicates the highest absolute peak recorded for this pile was 188 dB_{peak} with TNAP2. The highest RMS is with TNAP2 is 174 dB_{RMS}. The highest SEL for the peak strike is 163 dB_{SEL} with TNAP2. 100% of the strikes with TNAP2 exceeded 180 dB_{peak} and all strikes exceeded 150 dB_{RMS}. The average peak sound reductions achieved with TNAP2 ranged between 19 and 23 dB depending on which pile without mitigation the bubble curtain results were compared to (Pile R2 or Pile T2).

The single strike SEL in Table 2 did not exceed the proposed interim criteria of 187 dB_{SEL}. The calculated cumulative SEL for a total of 91 pile strikes is 207dB_{SEL} and did not exceed the proposed benchmark of 220 dB_{SEL}.

Figure 13: Waveforms and frequency spectral analysis for pile R3 using TNAP2.

a. Pile R3 (TNAP2)

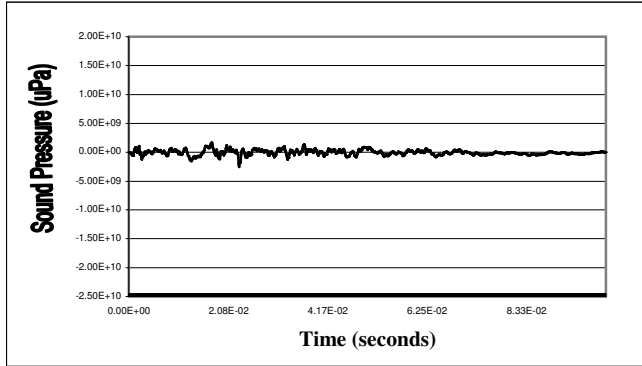

b. Pile R2 (No Mitigation)

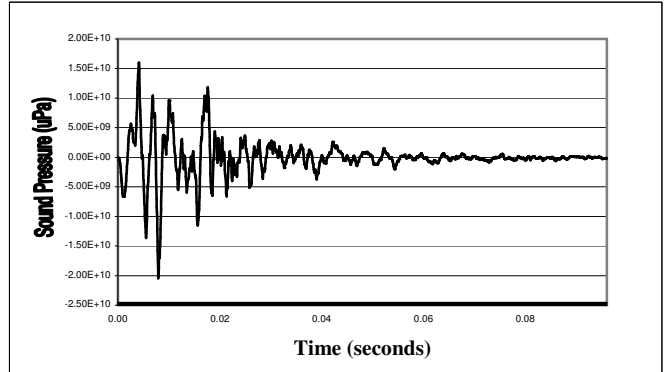

c. Pile R3 with TNAP2 Frequency Data Compared to Pile R2 with No Mitigation

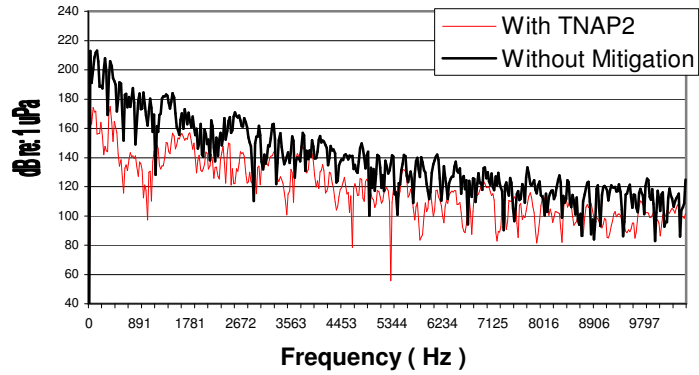

PILE R1

Pile R1 was driven in water depth of 26 feet and relatively firm sediments with the TNAP2 in place. To further test the effectiveness of TNAP2 it was decided to utilize TNAP2 on pile R1 so that we could get replicate results.

Figure 14a indicates the difference between the peak strike waveform with TNAP2 in place compared to pile R2 without mitigation (14b). This is a visual representation of a 15 to 19 decibel noise reduction that was calculated for the bubble curtain on this pile (Table 2).

In Figure 14c the narrow band frequencies of the peak pile strikes for the TNAP2 and no mitigation (pile R2) are compared. In this spectral analysis there appears to be suppression of both the upper and lower frequencies which also correlates to the drop in amplitude of the peak strike seen in figure 9a and the higher sound reductions associated with the lower frequencies.

Table 2 indicates the highest absolute peak recorded for this pile was 191 dB_{peak} with TNAP2. The highest RMS is with TNAP2 is 178 dB_{RMS}. The highest SEL for the peak strike is 166 dB_{SEL} with TNAP2. 99% of the strikes with TNAP2 exceeded 180 dB_{peak} and all strikes exceeded 150 dB_{RMS}. The average peak sound reductions achieved with TNAP2 ranged between 15 and 19 dB depending on which pile without mitigation the bubble curtain results were compared to (Pile R2 or Pile T2).

The single strike SEL in Table 2 did not exceed the proposed interim criteria of 187 dB_{SEL}. The calculated cumulative SEL for a total of 152 pile strikes is 209dB_{SEL} and did not exceed the proposed benchmark of 220 dB_{SEL}.

Figure 14: Waveforms and frequency spectral analysis for pile R1 using TNAP2.

a. Pile R1 with TNAP2

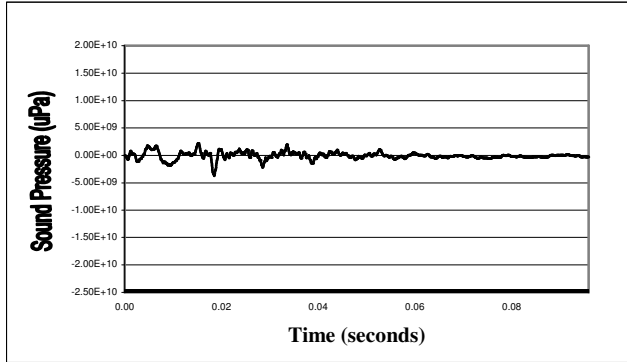

b. Pile R2 (No Mitigation)

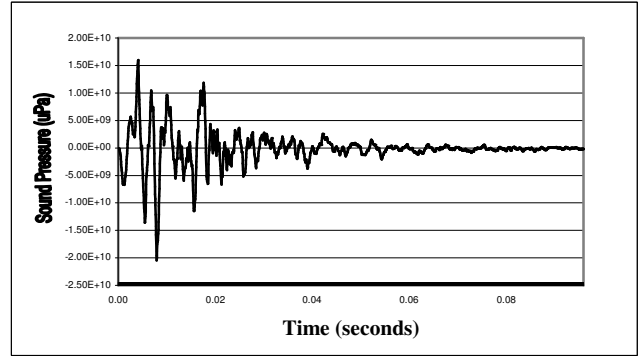

c. Pile R1 with TNAP2 Frequency Data Compared to Pile R2 with No Mitigation

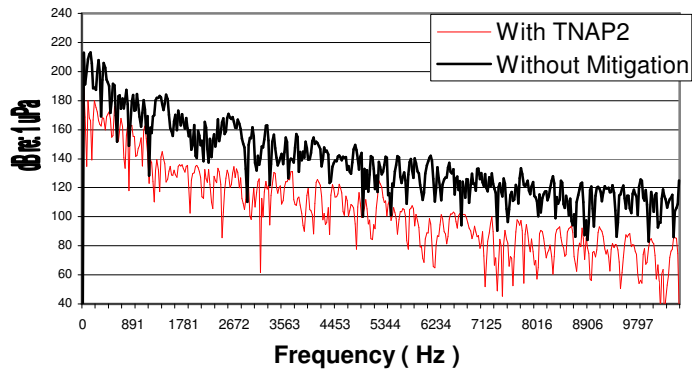

PILE T2

Pile T2 was driven in water depth of 27 feet in relatively soft sediments with a bubble curtain operating. The bubble curtain utilized two separate rings, one on the bottom and one 10 feet above the bottom. The air was turned on for the bottom ring only first then air to both rings was turned on. Then bubbles were turned off for approximately the last two minutes.

Figure 15a indicates the peak strike waveform with no bubble curtain. Figure 15b indicates the peak strike waveform with the air to only the bottom ring of the bubble curtain turned on. Figure 15c indicates the waveform with the air to both bottom and middle rings turned on. There is very little difference between the waveforms in 15b and 15c indicating that the addition of the second ring 10 feet above the bottom did very little to increase the noise reductions. These results are similar to what was observed for bubble curtain testing at the Friday Harbor pile driving monitoring in 2005 (Laughlin, 2005). The Friday Harbor results indicate that adding air from additional bubble curtain rings does not significantly increase sound reductions.

In Figure 15d the narrow band frequencies of the peak pile strikes for the bubbles off, bottom ring bubbles on, and both bottom and top bubbles on are compared. In this spectral analysis there appears to be suppression of both the upper and lower frequencies which also correlates to the drop in amplitude of the peak strike seen in Figure 15b and the higher sound reductions associated with the lower frequencies. There is also very little difference in the frequencies between having the bottom ring on only and both bottom and middle rings turned on.

Table 4 also provides additional support that adding the second bubble ring 10 feet above the bottom does not increase benefit in noise reductions. Table 4 indicates the highest absolute peak recorded for this pile was 214 dB_{peak} with the bubbles off and 188 dB_{peak} for both the bottom ring only and both rings on conditions. The highest RMS is 201 dB_{RMS} for the bubbles off condition, 172 dB_{RMS} for the bottom ring only condition, and 171 dB_{RMS} for both rings on condition. The highest SEL for the peak strike is 184 dB_{SEL} with no bubbles on, 162 dB_{SEL} with only the bottom ring bubbles on, and 161 dB_{SEL} with both bubble rings on. 97% of the strikes exceeded 180 dB_{peak} with the bubble curtain off and 95% exceeded 180 dB_{peak} with both the bottom ring and both rings on conditions. All the strikes exceeded 150 dB_{RMS}. The average peak sound reductions achieved with the bubble curtain was 22 dB with both the bottom ring only and both rings on.

The single strike SEL in Table 4 did not exceed the proposed interim criteria of 187 dB_{SEL}. The calculated cumulative SEL for a total of 408 pile strikes (Table 2) is 213 dB_{SEL} and did not exceed the proposed benchmark of 220 dB_{SEL}.

Figure 15: Waveforms and frequency spectral analysis for pile T2 using a bubble curtain.

a. Pile T2 bubbles Off

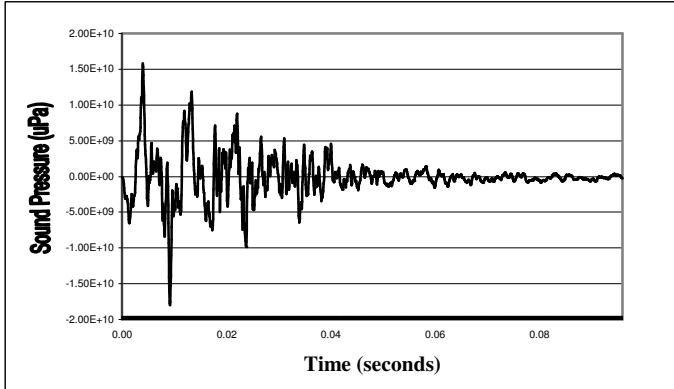

b. Pile T2 Bottom Ring Only

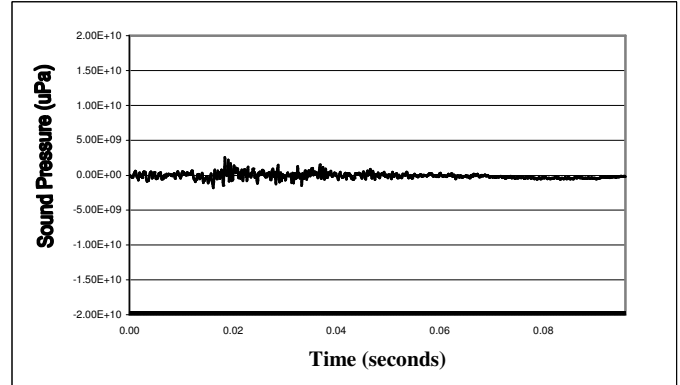

c. Pile T2 Both Rings On

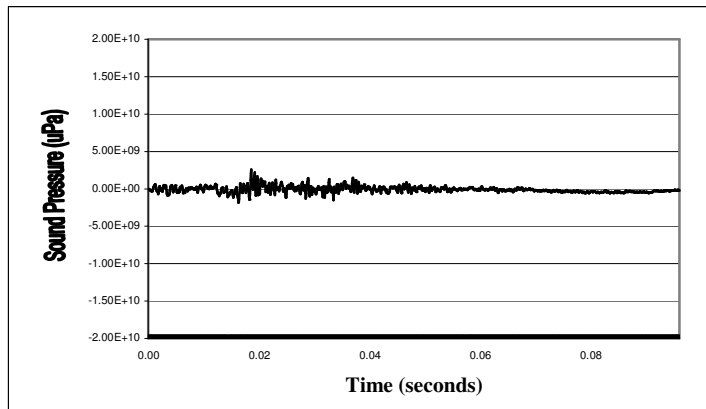

d. Pile T2 Frequency Data Compared to no bubble curtain.

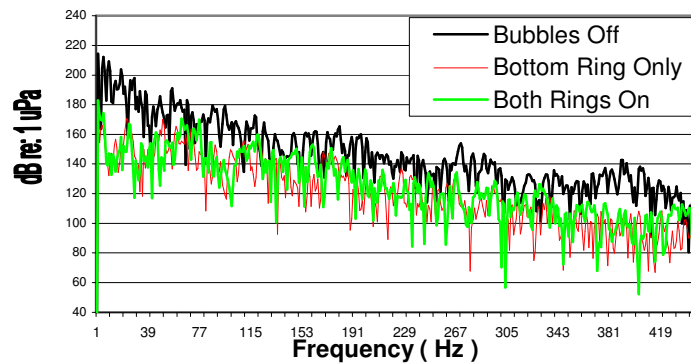

Table 4: Comparison of Additive Bubble Curtain Ring Usage Against the Bubbles Off Condition.

Pile	Date	Mitigation Type	Peak (dB)	RMS (dB)	Average RMS (Pascals)	Number of Strikes	Average Peak (Pascals)	Average Reduction (dB)	SEL (dB)	Rise Time (millesec.)	% of Strikes Over 180 dB
T2	11/16/06	Bottom Ring Only	188	172	362±85	19	1739±339	22	162	19.2	95
		Bottom and Top Ring	188	171	321±47	67	1731±3520	22	161	20.3	95
		Bubbles Off	214 ¹	201	3727±1579	29	22783±11058	-	184	17.2	97

¹ – Peak represents underpressure.

Another interesting observation was that for all of the steel piles there was a series of two and sometimes three Scholte waves or seismic reflections that occurred after the main pile strike (see Figure 16). This was observed on all pile strikes and they are generated at the water sediment interface. The first reflection occurred 0.1174 seconds after the initial strike and had a peak value of 176 dB_{peak}. This is likely site specific and a result of the softer sediment conditions at this location.

Figure 16: Pile T2 Pile Strike Indicating Seismic Reflections.

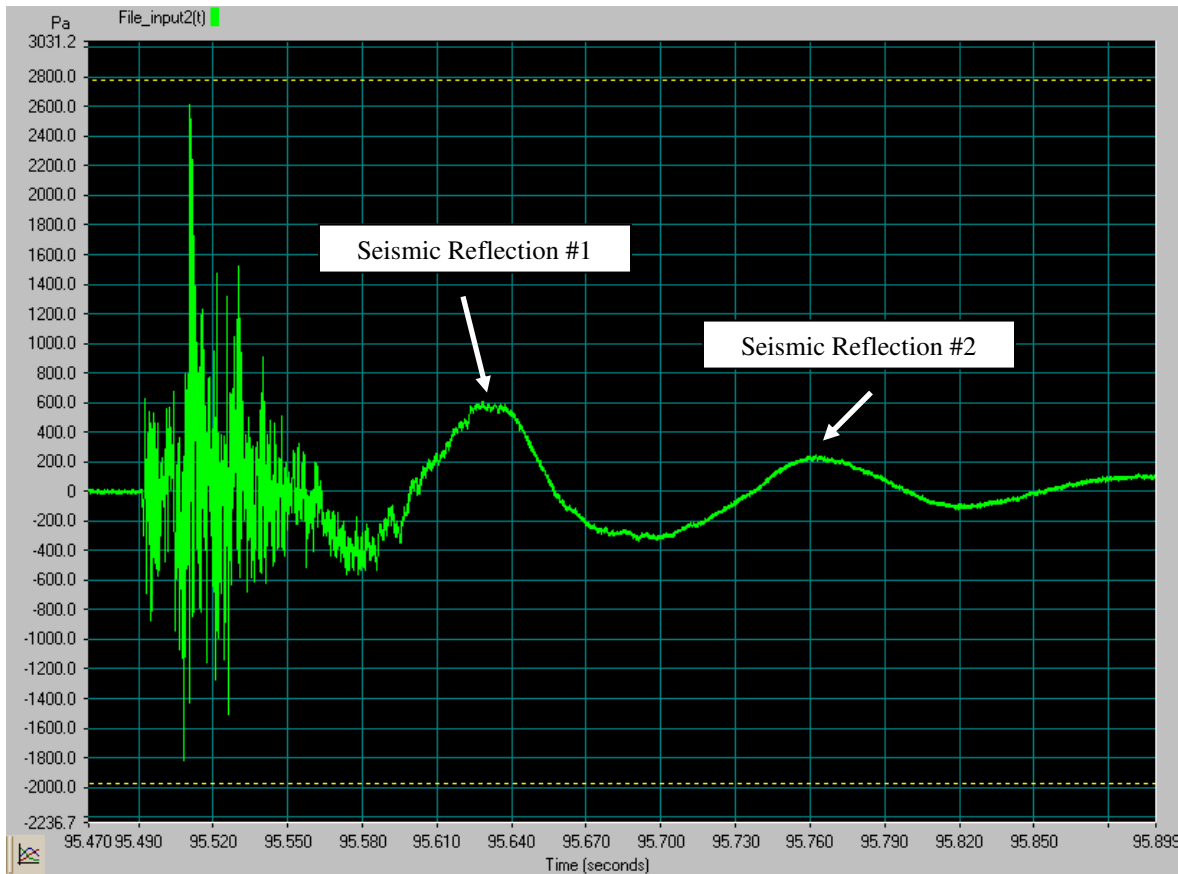

Concrete Piles

Measurements made for the two hollow concrete piles, T3 and T4, were made after a piece of equipment malfunctioned. The Nexus signal conditioner stopped working and so the hydrophones were connected directly to the digital analyzer bypassing the conditioner. This means that the raw recorded signal sound levels are less than the actual sound levels. Removing the signal conditioner created a 10X scaling factor for the raw signals. A 10X scaling factor was added to the analysis software post processing to bring the recorded levels up to the levels they are supposed to be.

However, while we will still report the results for these two piles in our report this scaling factor may not be exact and so the data and results for these two piles should be treated as suspect with regards to its accuracy.

PILE T1

Pile T1 was a 24-inch diameter octagonal solid concrete pile driven in a water depth of 25 feet in relatively firm sediments without a noise attenuation device. The diesel pile driving hammer included a 12-inch thick plywood pile cap (Figure 17) between the steel hammer and the concrete pile. Figure 17 shows three of the four 4-inch thick plywood disks that made the wood pile cap. As Figure 17 shows the disks were compressed to various thicknesses during the driving of the pile. Previous studies (Laughlin, 2006) have indicated that for 12-inch steel piles a wood pile cap can provide up to 24 dB sound reduction. It is not known if the previous study can be extrapolated to concrete but it is assumed that the wood pile cap is providing some level of sound level reduction.

Figure 18a indicates the peak strike waveform for the octagonal concrete pile. For comparative purposes Figure 18b indicates the peak strike waveform for a steel pile (T2) with no noise attenuation device. When these two figures are compared against each other it is apparent that the concrete pile generates much less sound energy into the water than the steel pile. Whether this is due to the wood pile cap, the concrete pile itself, or a combination of the two is not clearly understood. However, it is common practice for all concrete piles to utilize a wood cap.



Figure 17: Photograph of one of four previously used 4-inch thick plywood stacked disks that formed the wood pile cap for the concrete piles.

In Figure 12c, the narrow band frequencies of the peak pile strikes for the concrete pile and the steel pile (T2) without mitigation are compared. In this spectral analysis there appears to be suppression of both the upper and lower frequencies in the concrete pile which also correlates to the drop in amplitude of the peak strike seen in figure 12a and the higher sound reductions associated with the lower frequencies.

Table 5 indicates the highest absolute peak recorded for this concrete pile was 184 dB_{peak}. The highest RMS is 170 dB_{RMS}. The highest SEL for the peak strike is 159 dB_{SEL}. 64% of the strikes exceeded 180 dB_{peak}. All the strikes exceeded 150 dB_{RMS}.

The single strike SEL in Table 5 did not exceed the proposed interim criteria of 187 dB_{SEL}. The calculated cumulative SEL for a total of 184 pile strikes (Table 5) is 210 dB_{SEL} and did not exceed the proposed benchmark of 220 dB_{SEL}.

Figure 18: Waveforms and frequency spectral analysis for pile T1, a solid octagonal concrete pile with a 12-inch wood cap.

a. Pile T1 (concrete pile)

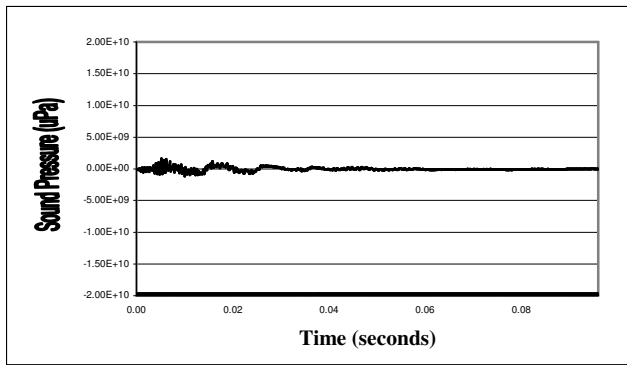

b. Pile T2 (steel pile) bubbles off

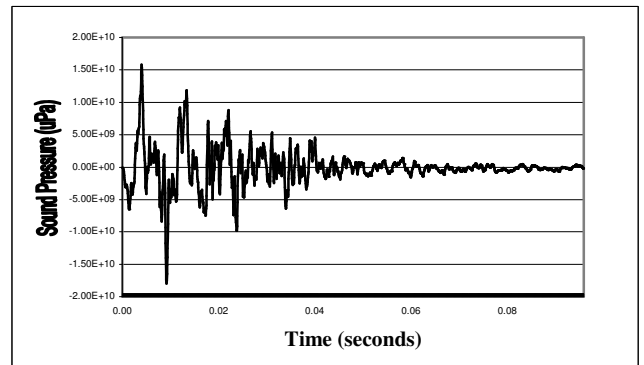

c. Pile T1 Frequency Data Compared to Steel Pile (T2)

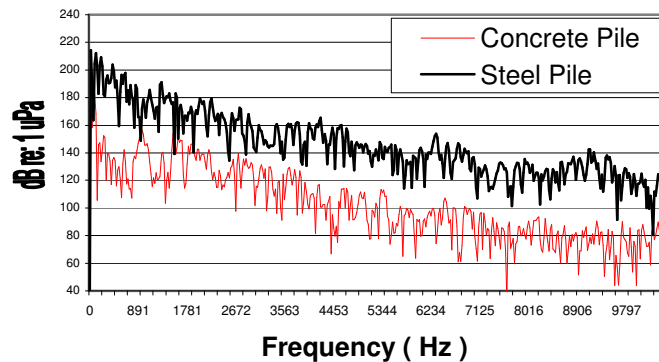

Table 5: Summary of Underwater Sound Levels for the Mukilteo Test Pile Project, Concrete Piles, Midwater

Pile	Date	Mitigation Type	Peak (dB)	RMS (dB)	Average RMS ± s.d. (Pascals)	Number of Strikes	Average Peak ± s.d. (Pascals)	Average Reduction (dB)	SEL (dB)	Rise Time (millesec.)	Cumulative SEL (dB) ²	% of Strikes Over 180 dB
T1 (solid octagonal)	11/20/06	None ¹	184	170	230±43	184	1075±248	-	159	5.4	210	64
T3 (hollow)	12/5/06	None ¹	193	183	575±102	204	3143±587	-	167	12.8	210	100
T4 (hollow)	12/5/06	None ¹	194	181	606±138	62	3466±849	-	167	12.7	205	100
T4 (hollow) (new wood cap)			196 ⁴	186	528±115	193	2742±607	-	170	10.4	210	97

¹ – A 12-inch wood pile cap was used on all the concrete piles. No measurements were taken without the caps but based on a previous study testing various pile cap materials wood pile caps can reduce sound levels substantially (up to 24 dB on 12-inch steel piles, Laughlin, 2006).

² – Cumulative SEL benchmark is 220 dB_{SEL} based on 1,995 pile strikes. Formula for calculating cumulative SEL is $10\log_{10}(\#strikes)+187\text{dB}_{\text{SEL}}$.

PILE T3

Pile T3 was a 36-inch diameter hollow concrete pile with a 6-inch thick wall driven in a water depth of 25 feet in relatively firm sediments without noise attenuation. The diesel pile driving hammer included a 12-inch thick plywood pile cap between the steel hammer and the concrete pile. Due to the failure of the signal conditioner for this pile this data has been corrected with a scaling factor of 10. While we feel that the data is reasonable it should still be considered to be not completely accurate.

Figure 19a indicates the peak strike waveform for the hollow concrete pile. For comparative purposes Figure 19b indicates the peak strike waveform for a steel pile (T2) with no mitigation. When compared the hollow concrete pile in Figure 19a is compared to the steel pile in Figure 19b the amplitude is much less than the steel pile.

Pile caps are necessary during driving of concrete piles in order to prevent the concrete from shattering during impact driving. Therefore, it was not possible to take noise measurements without the pile cap in place.

In Figure 19c the narrow band frequencies of the peak pile strikes for the concrete pile and the steel pile (T2) without mitigation are compared. In this spectral analysis there appears to be a substantial suppression of both the upper and lower frequencies in the hollow concrete pile which also correlates to the drop in amplitude of the peak strike seen in figure 19a and the higher sound reductions associated with the lower frequencies. Figure 19d the narrow band frequencies of the solid octagonal concrete pile are compared with the hollow concrete pile. As Figure 19d indicates there is very little difference in frequencies of the two piles except Since the 12-inch wood pile cap was used for both the octagonal and hollow concrete piles it is assumed that the reduction of higher frequencies is attributed to the pile cap.

Table 5 indicates the highest absolute peak recorded for this hollow concrete pile was 193 dB_{peak}. The highest RMS is 183 dB_{RMS}. The highest SEL for the peak strike is 167 dB_{SEL}. All the strikes exceeded 150 dB_{RMS}.

The single strike SEL in Table 5 did not exceed the proposed interim criteria of 187 dB_{SEL}. The calculated cumulative SEL for a total of 297 pile strikes (Table 5) is 212 dB_{SEL} and did not exceed the proposed benchmark of 220 dB_{SEL}.

Figure 19: Waveforms and frequency spectral analysis for pile T3, a hollow concrete pile with a 12-inch wood cap.

a. Pile T3 (concrete pile)

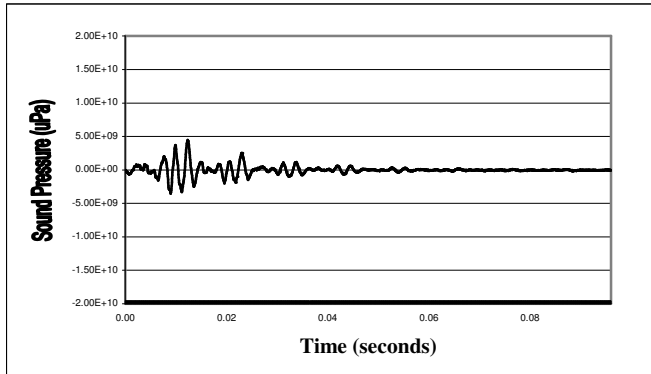

b. Pile T2 (steel pile) bubbles off

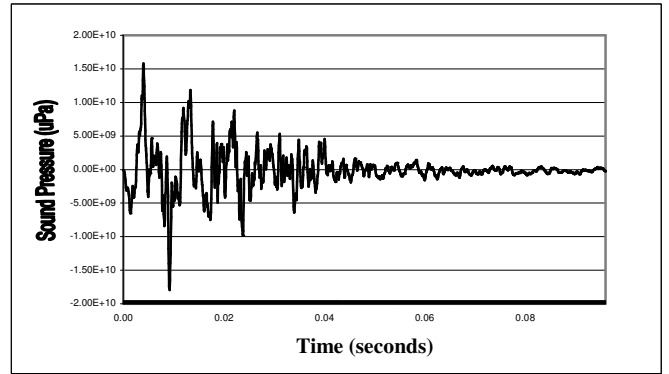

c. Pile T1 Frequency Data Compared to Steel Pile (T2)

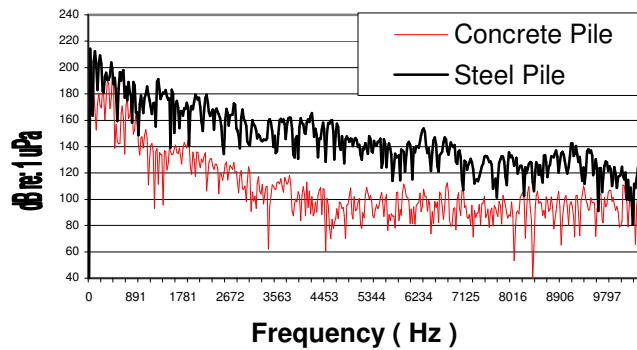

d. Comparison of Octagonal Concrete Pile T1 Frequency Data with Hollow Concrete Pile T3

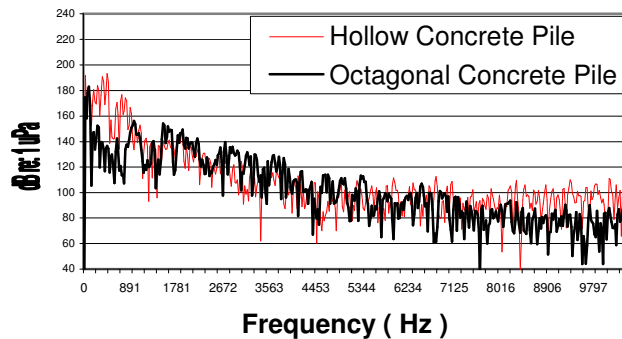

An interesting observation for the concrete piles was that Scholte waves were also seen for each strike. These are seen in Figure 20 as a series of four and sometimes five possible seismic

reflections that occurred after the main pile strike. This was observed on all concrete pile strikes and is unclear what caused this unusual waveform.

The first reflection occurred 0.0175 seconds after the initial strike and had a peak value of 176 dB_{peak}. The second reflection occurred at 0.0309 seconds and had a peak value of 168 dB_{peak}; the third reflection occurred at 0.0421 seconds with a peak of 156 dB_{peak}; and the fourth reflection occurred at 0.0538 seconds with a peak of 151 dB_{peak}.

Figure 20 Waveforms and frequency spectral analysis for pile T3, a hollow concrete pile with a 12-inch wood cap.

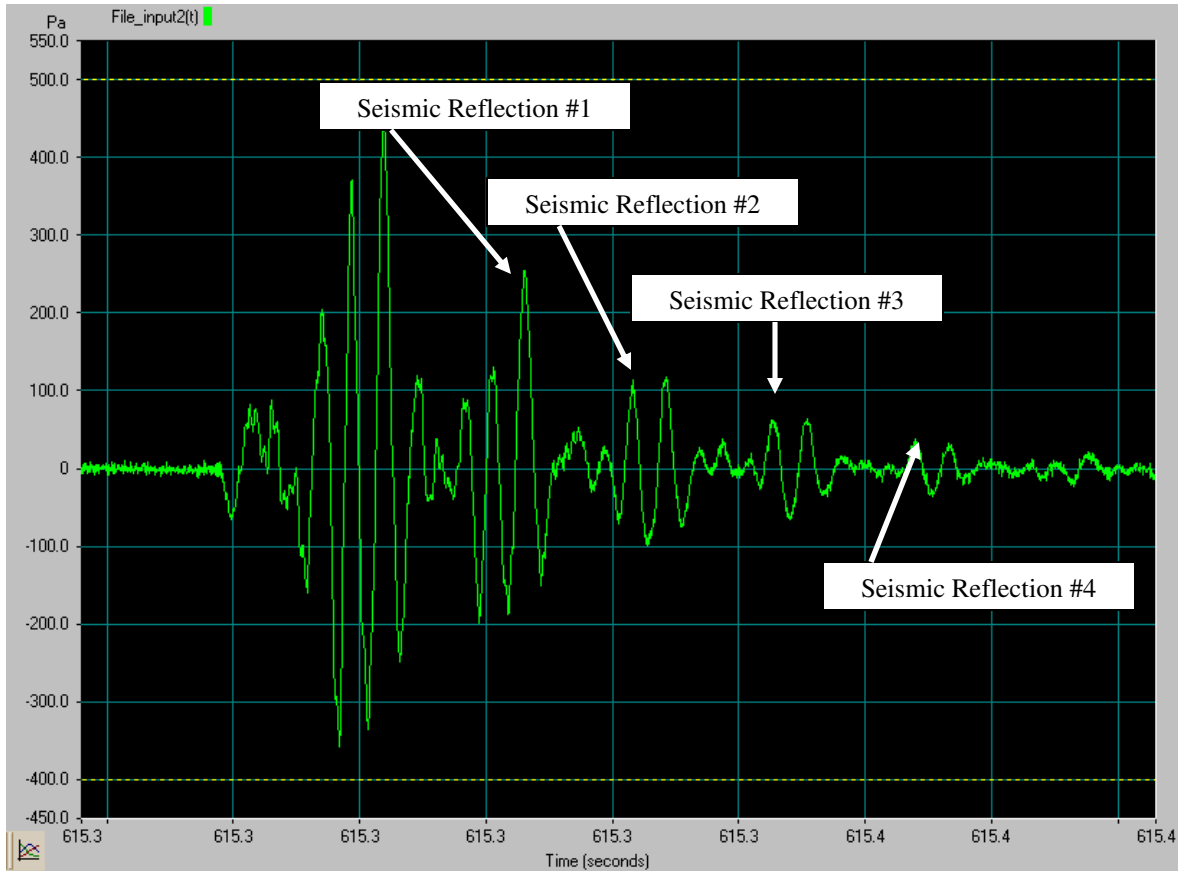

PILE T4

Pile T4 was a 36-inch diameter hollow concrete pile with a 6-inch thick wall driven in a water depth of 28 feet in relatively firm sediments without noise attenuation. The diesel pile driving hammer included a 12-inch thick plywood pile cap between the steel hammer and the concrete pile. Due to the failure of the signal conditioner for this pile this data has been corrected with a scaling factor of 10. While we feel that the data is reasonable it should still be considered to be not completely accurate.

Figure 20a indicates the peak strike waveform for the hollow concrete pile. For comparative purposes Figure 21b indicates the peak strike waveform for a steel pile (T2) with no mitigation. When these two figures are compared against each other it is apparent that the hollow concrete pile generates much less sound energy into the water than the steel pile. Since the 12-inch wood pile cap was used for both the octagonal and hollow concrete piles it is assumed that the structure of the hollow concrete pile provided additional noise reduction when compared to both the steel and octagonal concrete piles.

In Figure 21c the narrow band frequencies of the peak pile strikes for the hollow concrete pile and the steel pile (T2) without mitigation are compared. In this spectral analysis there appears to be a substantial suppression of both the upper and lower frequencies in the hollow concrete pile which also correlates to the drop in amplitude of the peak strike seen in figure 21a and the higher sound reductions associated with the lower frequencies.

Figure 21d compares the narrow band frequencies of the peak pile strikes for pile T4 with a new wood cap versus the old wood cap. There is a similar reduction with the new wood cap as seen when compared to the steel pile.

Table 5 indicates the highest absolute peak recorded for this hollow concrete pile was 194 dB_{peak} with the old wood cap and 196 dB_{peak} with the new wood cap. The highest RMS is 181 dB_{RMS} with the old wood cap and 186 dB_{RMS} with the new wood cap. The highest SEL for the peak strike is 167 dB_{SEL} with the old wood cap and 170 dB_{SEL} with the new wood cap. All the strikes exceeded 150 dB_{RMS}.

The single strike SEL in Table 5 did not exceed the proposed interim criteria of 187 dB_{SEL}. The calculated cumulative SEL for a total of 255 pile strikes (Table 5) is 211 dB_{SEL} and did not exceed the proposed benchmark of 220 dB_{SEL}.

Figure 21: Waveforms and frequency spectral analysis for pile T4, a hollow concrete pile with a 12-inch wood cap.

a. Pile T4 (concrete pile)

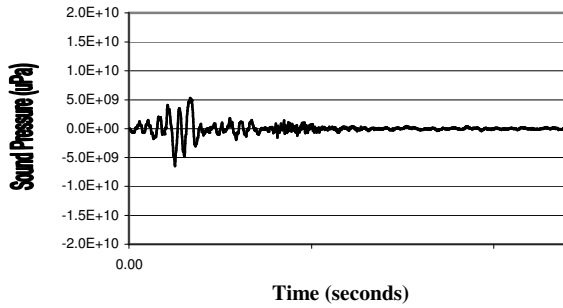

b. Pile T2 (steel pile) Bubbles Off

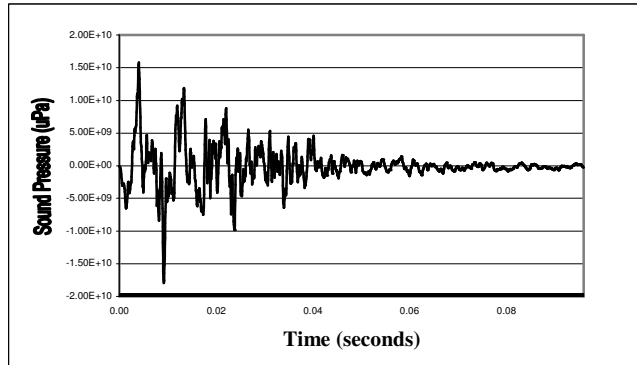

c. Comparison of Hollow Concrete Pile T4 Frequency Data with Steel Pile (T2) Without Mitigation.

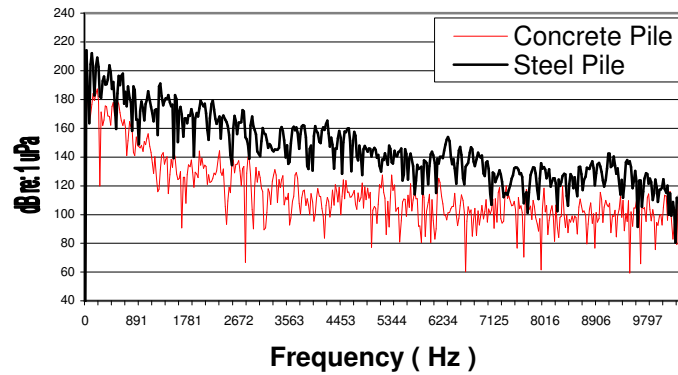

d. Comparison of Hollow Concrete Pile T4 Frequency Data using New Wood Cap vs. Old Wood Cap.

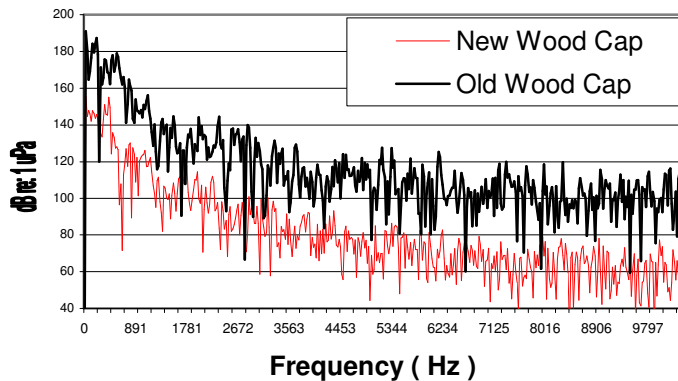

SEL

SEL was calculated for the single highest absolute peak strike for each pile. None of the SEL values for any of the piles monitored exceeded the proposed threshold of 187 dB SEL from Popper et al, (2006). Because decibels are on a logarithmic scale, it would require substantially more energy to exceed this threshold.

A total of 682 pile strikes for all five steel piles driven on 11/16/06 generated a cumulative SEL of 215 dB_{SEL}. A total of 184 pile strikes for one octagonal concrete pile on 11/20/06 generated a cumulative SEL of 210 dB_{SEL} and a total of 750 pile strikes for two hollow concrete piles driven on 12/5/06 generated a cumulative SEL of 216 dB_{SEL}. This is assuming that all pile strikes are at or above the 187 dB_{SEL} SEL level, which they were not, and that the pile driving continued without breaks for all 682 strikes, which it did not.

Rise Time

Yelverton (1973) indicated rise time was the cause of injury. According to Yelverton (1973), the closer the peak is to the front of the impulse wave the greater the chance for injury. In other words, the shorter the rise time the higher the likelihood for effects on fish.

In all steel piles without effective mitigation the rise times were relatively short and those with mitigation had relatively long rise times. This could be an indication that the pile was ringing due to the relatively hard substrate or an indication of sound flanking where most of the energy was not traveling directly through the water but through the sediment up to the hydrophone.

However, this relationship is not entirely clear.

AIRBORNE NOISE MEASUREMENTS

Characteristics of Airborne Noise

SOUND

Sound is created when objects vibrate, resulting in a minute variation in surrounding atmospheric pressure. This is called *sound pressure*. The human response to sound depends on the magnitude of a sound as a function of its frequency and time pattern (EPA, 1974). Magnitude measures the physical sound energy in the air. The range of magnitude, from the faintest to the loudest sound that the ear can hear, is so large that sound pressure is expressed on a logarithmic scale in units called decibels (dB). Loudness, compared to physical sound measurement, refers to how people subjectively judge a sound and this varies from person to person. Noise is unwanted sound.

SOUND CHARACTERISTICS AND HUMAN RESPONSE

Humans respond to a sound's frequency or pitch. The human ear is very effective at perceiving sounds that have a frequency between approximately 1,000 and 5,000 Hz, and human hearing decreases outside this range. Environmental noise is composed of many frequencies, each occurring simultaneously at its own sound-pressure level. Frequency weighting, which is applied electronically by a sound level meter, combines the overall sound frequency into one sound level that simulates how an average person hears sounds. The commonly used frequency weighting for environmental noise is A-weighting (dBA), which is most similar to how humans perceive sounds of low to moderate magnitude.

HOW HUMANS PERCEIVE NOISE

Because of the logarithmic decibel scale, a doubling of the noise sources (e.g., the number of cars operating on a roadway) increases noise levels by three dBA. A ten-fold increase in the number of noise sources will add 10 dBA. As a result, a source that emits a sound level of 60 dBA, combined with another source of 60 dBA, yields a combined sound level of 63 dBA (not 120 dBA). The human ear can barely perceive a three dBA increase, but a ten dBA increase appears to be a doubling in noise level.

FACTORS AFFECTING TRAFFIC NOISE

Noise levels from traffic sources depend on volume, speed, and the type of vehicle. Generally, an increase in volume, speed, or vehicle size increases traffic noise levels. Vehicular noise is a combination of sounds from the engine, exhaust, and tires. Other conditions affecting traffic noise include defective mufflers, steep grades, terrain, vegetation, distance from the roadway, and shielding by barriers and buildings.

ENVIRONMENTAL EFFECTS ON NOISE

Noise levels decrease with distance from the source. For a point source such as construction, noise levels decrease between 6 dBA and 7.5 dBA for every doubling of distance from the source.

The type of terrain and the elevation of the receiver relative to the noise source can greatly affect the propagation of noise. Level ground is the simplest scenario: sound travels in a straight line-of-sight path between the source and receiver.

SOUND LEVEL DESCRIPTORS

A widely used descriptor for environmental noise is the equivalent sound level (L_{eq}). The L_{eq} can be considered a measure of the average sound level during a specified period of time. It is a measure of total noise, or a summation of all sounds during a time period. It places more emphasis on occasional high noise levels that accompany general background sound levels. L_{eq} is defined as the constant level that, over a given period of time, transmits to the receiver the same amount of acoustical energy as the actual time-varying sound. For example, two sounds, one containing twice as much energy but lasting only half as long, have the same L_{eq} noise levels. L_{eq} measured over a one-hour period is the hourly L_{eq} [$L_{eq}(h)$] this is used for highway noise impact and abatement analyses.

EFFECTS OF NOISE

Prolonged exposure to very high levels of environmental noise can cause hearing loss. The EPA has established a protective level of 70 dBA L_{eq} , below which hearing is conserved for exposure over a 40-year period (U.S. EPA, 1974). Although scientific evidence is not currently conclusive, noise is suspected of causing or aggravating other diseases. Environmental noise indirectly affects human welfare by interfering with sleep, thought, and conversation. The FHWA noise abatement criteria are based on speech interference, which is a well documented impact that is relatively reproducible in human response studies.

NOISE REGULATIONS AND IMPACT CRITERIA

Applicable noise regulations and guidelines provide a basis for evaluating potential noise impacts. For Type I state and federally funded highway projects, traffic noise impacts occur

when predicted $L_{eq}(h)$ sound levels approach or exceed the noise abatement criteria (NAC) established by the FHWA, or substantially exceed existing sound levels (U.S. Department of Transportation, 1973, Noise Abatement Council). The term "substantially exceed" is defined by WSDOT as an increase of 10 dBA or more.

The FHWA noise abatement criteria specify exterior $L_{eq}(h)$ noise levels for various land activity categories (Table 6). For receptors where serenity and quiet are of extraordinary significance, the noise criterion is 57 dBA. For residences, parks, schools, churches, and similar areas, the noise criterion is 67 dBA. For developed lands, the noise criterion is 72 dBA. WSDOT considers predicted noise levels of 1 dBA below the NAC criteria of 67 dBA as sufficient to satisfy the condition of approach. For example, since the NAC for residences is 67 dBA, the approach criterion is one dBA below 67 dBA at 66 dBA.

Table 6: FHWA Noise Abatement Criteria

Activity Category	$L_{eq}(h)$ (dBA)	Description of Activity Category
A	57 (exterior)	Lands on which serenity and quiet are of extraordinary significance and serve an important public need, and where preserving these qualities is essential if the area is to continue to serve its intended purpose.
B	67 (exterior)	Picnic areas, recreation areas, playgrounds, active sports areas, parks, residences, motels, hotels, schools, churches, libraries, and hospitals.
C	72 (exterior)	Developed lands, properties, or activities not included in Categories A or B above.
D	-	Undeveloped lands.
E	52 (interior)	Residences, motels, hotels, public meeting rooms, schools, churches, libraries, hospitals, and auditoriums.

Source: U.S. Department of Transportation, 1982.

Land use in the study area includes residential, parks, commercial, industrial, schools and some undeveloped uses.

AIRBORNE NOISE MEASUREMENT METHODS

Type 2 sound level meters were programmed to make 3-second measurements every 3 seconds and record the L_{max} , thus capturing most, but not all, of the individual pile strikes. The sound level meters can only be programmed to collect measurements every one second or every three seconds while pile strikes occur approximately every 1.5 seconds. Therefore, we had to make a choice to collect every pile strike until the internal memory buffer filled up and risk not recording pile strikes at the end of the drive event or collect most of the pile strikes throughout the pile drive event. The latter choice was decided to be the best alternative.

Airborne noise measurements were made at three separate locations (Figure 22). Unfortunately due to issues with the noise meter, noise data was not collected at all locations for all piles. Data was collected from:

- In a boat 300 feet from the pile being driven
- Onshore 300 feet from the pile being driven
- Onshore approximately 2,300 feet from the pile being driven beneath the nearest eagles nest.

There were occasional freight and commuter trains and low flying commercial aircraft that went past these locations blowing their horns or causing jet noise. These events were noted on the data sheets and the following figures but excluded from the following table values. In addition ambient measurements were made while pile driving was not in operation.



Figure 22: Airborne monitoring Locations.

Offshore Airborne Noise Measurements On a Boat

Table 7 indicates the airborne L_{max} values for each pile monitored in a boat 300 feet from each pile being driven with the exception of the octagonal concrete pile T1. The airborne noise data from pile T1 was lost. The boat was not able to be anchored so the boat's motor was used to hold position. The boat's motor noise levels did not interfere with the L_{max} for the individual pile strikes because the pile strike sound levels were the dominant noise source. However, the boat's motor may have influenced the ambient noise levels measured. The ambient noise levels are represented by the L_{95} values plotted in Figure 23 because these values represent the noise levels that occur more than 95% of the time during a measurement. The ambient levels for all piles measured ranged between 66 and 73 dBA. The L_{eq} or equivalent noise level is considered a general environmental descriptor of all sounds made in the environment, both ambient and construction noise levels.

Monitored Sound Level in Boat, 300 Feet Over Water to Pile Locations.							
Pile ²	Pile Type and Mitigation Method	Date	Ambient Levels		Pile Strike Sound Levels		
			L_{eq} (dBA)	L_{MAX} (dBA)	L_{MAX} (dBA)	Average L_{MAX} (Pascal)	Average L_{MAX} (dBA)
T2	36" Steel Pile 1"Wall w/ & w/o BC ¹	11/14/06	67.4	72.7	96.7	1.3093	89.3
R4	36" Steel Pile 1"Wall w/ double Wall TNAP	11/16/06	67.4	72.7	93.4	0.9398	92.0
R3	36" Steel Pile 1"Wall w/ Foam TNAP	11/16/06	67.4	72.7	94.1	1.0093	90.0
R2	36" Steel Pile 1"Wall w/ & w/o BC	11/16/06	67.4	72.7	94.8	1.0953	92.3
R1	36" Steel Pile 1"Wall w/ Foam TNAP	11/16/06	67.4	72.7	93.2	0.9089	91.0
T3	36" Hollow Concrete Pile	12/5/06	67.4	72.7	98.3	1.4306	93.3
T4	36" Hollow Concrete Pile	12/5/06	67.4	72.7	94.7	1.0364	91.1

¹ - BC = Bubble curtain

² - The solid octagonal concrete pile (T1) airborne noise data was lost.

Table 7: Summary of Airborne Sound Levels for the Mukilteo Test Pile Project, Steel and Concrete Piles, on a Boat, 300 feet from the pile.

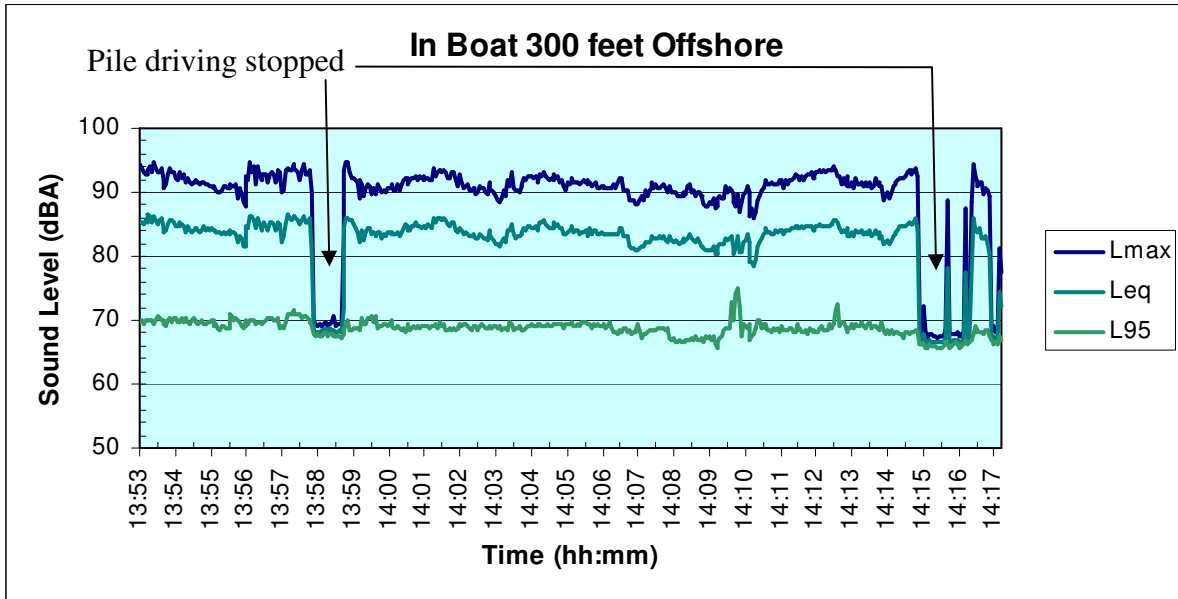

Figure 23: Typical plot of L_{max} , L_{95} , and L_{eq} for all pile strikes measured at the offshore site in a small boat for pile T4.

Top of Wall Onshore Airborne Noise Measurements

Table 8 indicates the airborne L_{max} values for each pile monitored from the top of a 10 foot wall approximately 320 feet from the pile being driven with the exception of piles R1, R3 and T1 whose data was lost. The ambient noise levels are represented by the L_{95} values plotted in Figure 24. The ambient noise levels ranged between 55 and 69 dBA.

The train horn noise level (L_{max}) at the wall, Figure 24, is 96.2 dBA. The ambient noise levels are represented by the L_{95} values plotted in Figure 24 because these values represent the noise levels that occur more than 95% of the time during a measurement. The L_{eq} or equivalent noise level is considered a general environmental descriptor of all sounds made in the environment, both ambient and construction noise levels.

Monitored Sound Level on Wall 320 Feet to Pile Locations.							
Pile ²	Pile Type and Mitigation Method	Date	Ambient Levels		Pile Strike Sound Levels		
			L _{eq} (dBA)	L _{MAX} (dBA)	L _{MAX} (dBA)	Average L _{MAX} (Pascal)	Average L _{MAX} (dBA)
R4	36" Steel Pile 1"Wall w/ double Wall TNAP	11/14/06	65.9	84.4-86.1	87.5	0.4754	80.1
T2	36" Steel Pile 1"Wall w/ & w/o BC ¹	11/14/06	65.9	84.4-86.1	97.3	1.4656	89.8
R2	36" Steel Pile 1"Wall w/ & w/o BC	11/15/06	65.9	84.4-86.1	95.3	1.1629	83.3
T3	36" Hollow Concrete Pile	12/5/06	64.9	75.7	92.8	0.8690	89.3
T4	36" Hollow Concrete Pile	12/5/06	68.6	81.9	94.0	0.9978	90.3

¹ - BC = Bubble curtain

² - The airborne data for steel piles R1 and R3 and octagonal concrete pile (T1) were lost.

Table 8: Summary of Airborne Sound Levels for the Mukilteo Test Pile Project, Steel and Concrete Piles, on Top of Wall, 300 Feet from Pile.

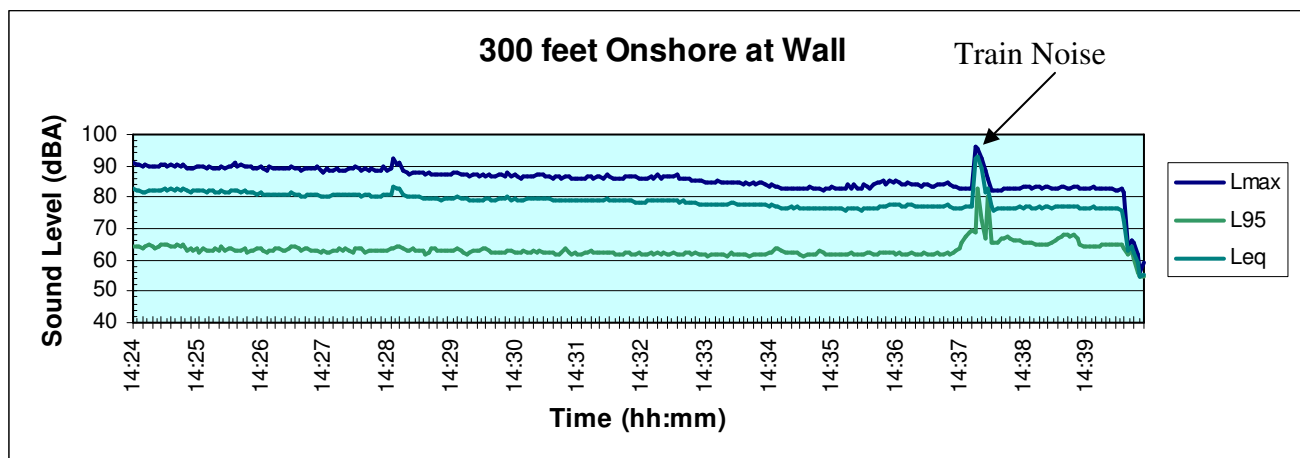

Figure 24: Typical plot of L_{max}, L₉₅, and L_{eq} for all pile strikes measured at the wall for pile T4.

Eagles Nest Airborne Noise Measurements

The train horn noise level (L_{max}) at the eagles nest, Figure 25, is 83.2 dBA and correlates with the same spike a little over 2 minutes before the end of the pile drive where the train horn noise is shown on Figure 24 for the top of wall measurement.

Table 9 indicates the airborne L_{max} values for each pile monitored with a microphone mounted on a 25 foot pole held under the existing eagle's nest approximately 2,300 feet from the pile being driven. In this location, eagles were observed visiting, performing repairs and perching on the nest during pile driving. Large commercial airplanes, small private planes, and helicopters were also observed flying directly over the eagles nest at low altitude prior to landing at Paine

Field Airport. Noise levels for the aircraft overflights ranged between 60 and 87 dBA. Train horn noise levels at the eagles nest for other piles measured ranged between 61 dBA and 84 dBA L_{max} . The ambient noise levels are represented by the L_{95} values plotted in Figure 25. They ranged between 48 and 68 dBA. The L_{eq} or equivalent noise level is considered a general environmental descriptor of all sounds made in the environment, both ambient and construction noise levels.

Monitored Sound Level at Eagle Nest Over 2,300 Feet to Pile Locations.							
Pile ²	Pile Type and Mitigation Method	Date	Ambient Levels		Pile Strike Sound Levels		
			L_{eq} (dBA)	L_{MAX} (dBA)	L_{MAX} (dBA)	Average L_{MAX} (Pascal)	Average L_{MAX} (dBA)
T2	36" Steel Pile 1"Wall w/ & w/o BC ¹	11/14/06	51.0	52.6-86.9	79.8	0.1963	72.8
R2	36" Steel Pile 1"Wall w/ & w/o BC	11/15/06	51.0	52.6-86.9	83.9 ³	0.3144	77.1
T1	24" Octagonal Concrete Pile	11/20/06	51.2	56.7	67.7	0.0484	64.6
T3	36" Concrete Pile 6"Wall	12/5/06	54.0	59.5-62.3	80.5	0.2114	72.7
T4	36" Concrete Pile 6"Wall	12/5/06	54.0	59.5-62.3	77.3	0.1472	77.3

¹ - BC = Bubble curtain

² - The airborne data for steel piles R1, R3, and R4 were lost.

³ - The shape of the curve for this measurement is good for a pile strike of this nature but field notes at another site indicate this sound level may have been influenced by sources other than by the pile driving operation.

Table 9: Summary of Airborne Sound Levels for the Mukilteo Test Pile Project, Steel and Concrete Piles, Below Eagles Nest, 2,300 Feet from Pile.

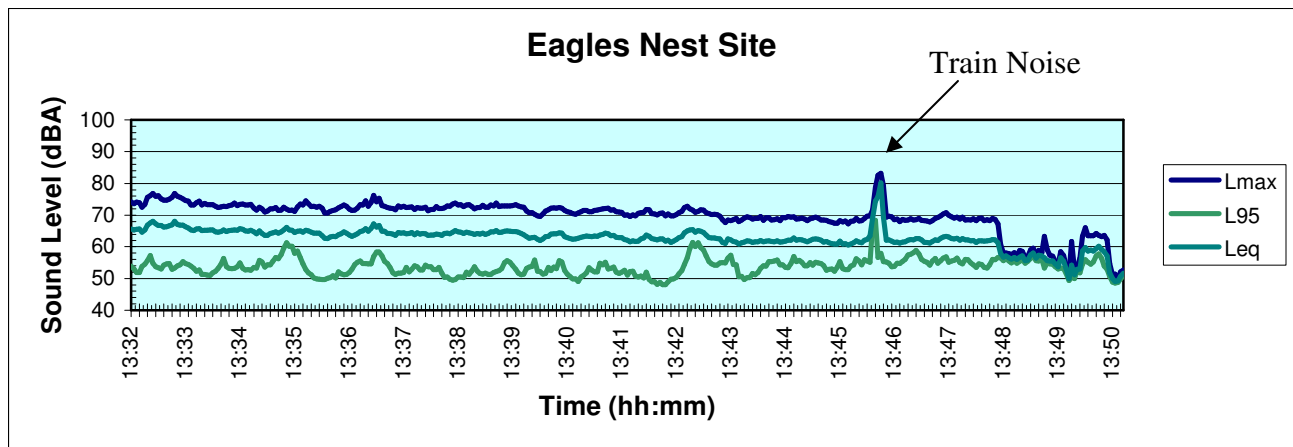
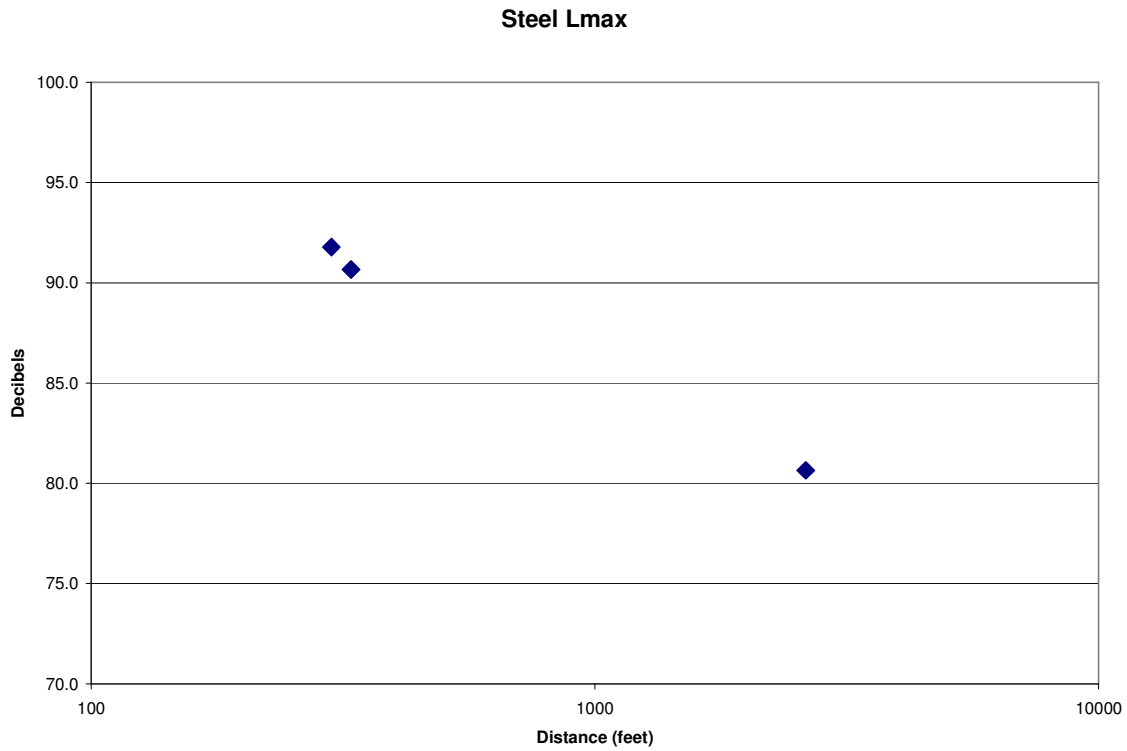

Figure 25: Typical plot of L_{max} , L_{95} , and L_{eq} for all pile strikes measured at the eagles nest site for pile T4.

Figure 26 indicates the average L_{max} sound levels of pile strikes through air over distance. The data collected at the 20 meter range was not in a format that was comparable to the results below,

therefore, the 20 meter data were not able to be used in the plots below. Because the plots below have only two points a regression line is not appropriate for the data.



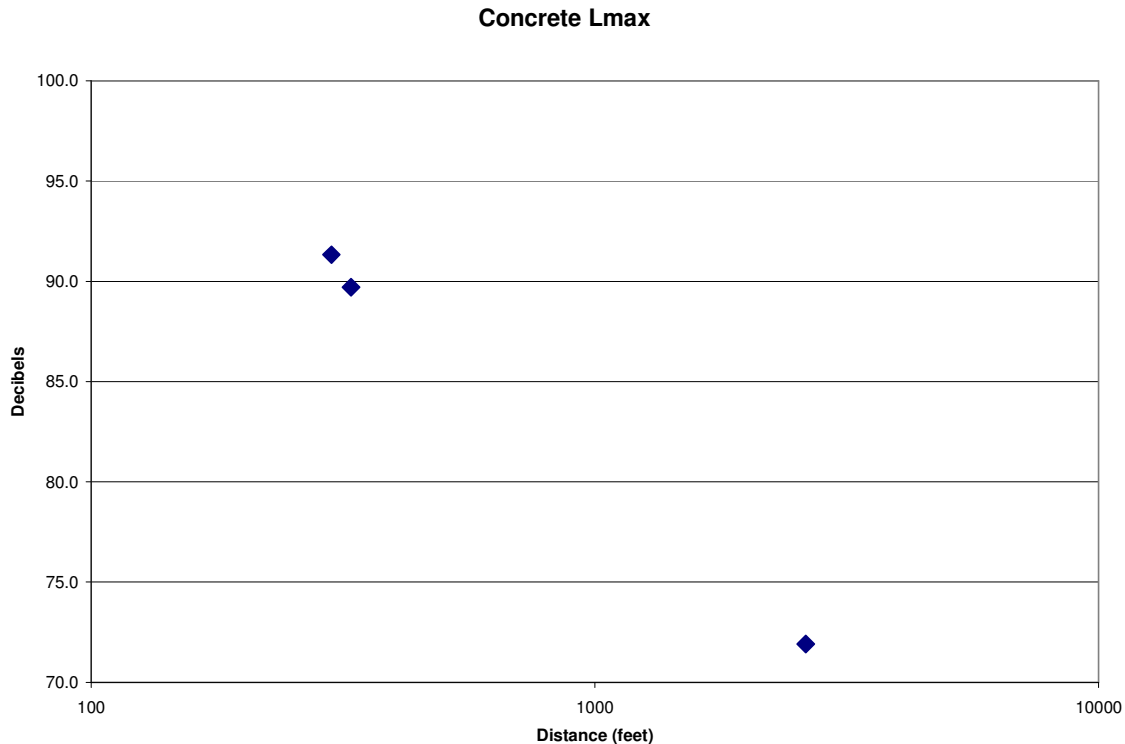

Figure 26: Plot of airborne average Lmax sound levels over distance for pile strikes at Mukilteo, Washington.

BIOLOGICAL OBSERVATIONS

Prior to pile driving, several juvenile Shiner Perch (*Cymatogaster aggregata*) were observed between the fuel pier and the steel piles near the surface, possibly feeding. On 11/14/06, one juvenile shiner perch was killed while driving pile R4 while TNAP1 was in place. This was likely due to a leak that had developed in the hollow wall of TNAP1 allowing water into that space and negating any attenuation properties.

On 11/15/06, one shiner perch was killed while driving pile R2 without the bubble curtain operating. The fish was initially stunned and appeared floating at the surface and then later died. Since individual pile strikes were separated by several seconds during this period of hammer startup the peak causing the fish mortality was able to be isolated. The peak value for the strike that caused the fish kill was 209 dB_{peak}. This value was determined by looking at the pile strike immediately prior to the observation of the fish kill. The RMS value was 202 dB_{RMS} and the SEL was 183 dB_{SEL}. The rise time was 1.5 seconds.

Two additional shiner perch were killed on 11/17/06 while driving pile R4 with TNAP1 in place (Figure 27). The peak value for the strike that caused the fish kill was 183 dB_{peak}. This value was determined by looking at the pile strike immediately prior to the observation of the fish kill. At this time there was several seconds between each pile strike. The RMS value was 171 dB_{RMS} and the SEL was 164 dB_{SEL}. The rise time was 23 milliseconds. Because the noise metrics were relatively low for these two fish kills we believe that they were killed within the near field area

less than 10 meters around the pile and possibly right next to the pile as we have observed them behave at other project sites where the sound levels would be much higher than those measured at 10 meters.

After the fish kill during the initial drive of pile R2, the bubble curtain on pile R2 was turned on. For pile R4, the bubble curtain was left on pile R2 and turned on during the remainder of the drive for pile R4. No other perch were killed. So it appears that bubble curtains are effective in scaring juvenile fish out of the near field area around the pile and can prevent fish kills in this manner rather than reducing sound levels outside the acoustical nearfield.

The WSDOT wildlife biologist (Michael MacDonald) on site observing other animals besides fish listed the species observed before, during, and after pile driving and made notes of their behavior. The following is a list of animals seen during the Mukilteo test pile driving on 11/16/06:

- Peregrine falcons – a pair (male and female – both unbanded) were seen from 8:00am until 11:30am. When we first arrived on site the female was plucking a pigeon prey on an old pier luminal approximately 150 feet from the pile driver. She had nearly finished the meal when the pile driving started and flushed from her perch after five strikes dropping the carcass as she departed. When the pile driving stopped one or both peregrines would perch on the upper most parts of the pile driving crane otherwise they were seen foraging over the water or perched on other luminars.
- California sea lions (2)
- Harbor seal (1) – both marine mammal species were only seen before and after the pile driving. None were observed during the pile strikes.
- Pile perch (4) – unsure if they were this common name species. All four found dead after baseline test pile strikes.

Figure 27: Photograph of two of the three striped pile perch that were killed as a result of driving steel piles without mitigation near the Mukilteo fuel pier.



- Great blue herons (at least 6) – Seen perched on old pier luminars approximately 675 feet from the pile driving. None were flushed by the pile driving.
- Glaucous-winged gulls (a couple dozen)
- Surf scoters (dozens)
- Goldeneyes (probably common goldeneye but may have had Barrows' mixed in too) (dozens)
- Northwest crows (dozen)
- Unk duck and cormorant species (dozen)
- Double crested cormorants (<dozen)
- Western grebes (~6)
- Bald eagles (2) – seen circling over the marine water approximately ¼ to ½ mile away during pile driving.
- Herring gull(?) (1)
- Pied-billed grebe (1)
- Belted kingfisher (1)
- European starlings (~6)
- Rock pigeons (~6)
- Tree sparrows (2)
- River otter (1) – seen at the end of the old pier circling (foraging???)

None of the diving birds observed indicated signs of distress or abnormal behavior. Future studies should identify a “control” area that is biologically similar. Biological observations in the control area could be compared to those in the study (treatment) area to help identify biological impacts of construction activity. The control area could be the study area but with observations made before construction and following. Without this type of comparison between control (or “no” treatment areas) and treatment areas it is very hard to evaluate the significance (if any) of the biological observation presented.

CONCLUSIONS

TNAP1 had developed a leak in the hollow wall and so results from the first test were inconclusive. One juvenile shiner perch was killed while hammering on this pile. A second test with a repaired TNAP1 on 2/19/07 resulted in sound level reductions of 12 to 17 dB. TNAP1 and TNAP2 exhibited noise reductions similar to the bubble curtain and well above any previous noise reductions observed on other projects within Puget Sound. The bubble curtain was slightly modified from the Friday Harbor design and exhibited remarkable noise reductions. No additional benefit of noise reductions was obtained by adding air from a second bubble ring above the ring on the bottom. Replicate measurements using the bubble curtain and TNAP2 indicated that the results of the first test of these mitigation devices were valid and reproducible.

The noise reductions when compared to pile R2 (baseline) were generally lower than when compared to pile T2. This is likely due to subtle differences in the sediment where these two piles were installed even though they are only about 20 feet apart. The sediment where pile T2 was installed was relatively firm and provided more resistance than the sediment where pile R2 was installed. Because the sediment where T2 was installed was more firm it provided more resistance and allowed for the production of higher baseline noise levels. When compared to the piles using a TNAP or bubble curtain this difference is greater when the baseline noise levels are higher. It could also be caused by differences in the hammer energy applied to the pile but these data are not presented in this report.

None of the single strike SEL values calculated on the absolute peak pile strike exceeded the proposed threshold of 187 dB SEL (Popper et al., 2006). None of the calculated cumulative SEL values exceeded the benchmark of 220 dB_{SEL} based on the total number of pile strikes for each individual pile and total pile strikes for the entire day. Therefore, while a couple of the piles without functioning mitigation caused mortality in a few juvenile perch, it is unlikely that any of the piles driven with mitigation for this project would have caused physical injury or mortality to fish, and none were observed.

However, without functioning attenuation and not exceeding the dual criteria, fish were killed. We believe this occurred because the fish were closer to the pile than where the measurements were made and exposed to sound levels above the dual criteria. The shiner perch killed during pile driving were observed to float to the surface less than 10 meters from the pile. It is therefore assumed that the perch were exposed to higher SEL levels than were measured at 10 meters. It is likely that those SEL values were much closer to or even higher than the interim dual criteria of 208 dB_{peak} and 187 dB_{SEL}.

Airborne L_{max} noise measurements at the eagles nest indicate that the commercial aircraft flights over the nest and the train horn noise L_{max} noise levels are much higher than the noise generated from pile strikes 2,300 feet away. The pile driving is temporary in nature and the aircraft flights and train horns occur several times daily.

As a result of these tests, it is recommended that TNAP2 could be used as an alternative to the bubble curtain as an underwater noise mitigation device. We do not recommend airborne mitigation for this area on future projects for the protection of wildlife in the area immediately adjacent to the pile driving or at the nearby eagles nest because noise levels in the immediate project area do not appear to affect wildlife and sound levels at the nearby eagles nest are below the current thresholds.

REFERENCES

- Hastings, M. C. (1995). "Physical effects of noise on fishes." Proceedings of INTER-NOISE 95, The 1995 International Congress on Noise Control Engineering, vol. II, pp. 979–984.
- Hastings, Mardi C., 2002. Clarification of the Meaning of Sound Pressure Levels and the Known Effects of Sound on Fish. White Paper. August 2002.
- Hastings, Mardi C.; and Arthur N. Popper. 2005. Effects of Sound on Fish. White Paper. January 2005.
- Laughlin, Jim, 2005. Underwater Sound Levels Associated with Restoration of the Friday Harbor Ferry Terminal, WSDOT Monitoring Report, May 2005.
- Laughlin, Jim, 2006. Underwater Sound Levels Associated with Pile Driving at the Cape Disappointment Boat Launch Facility, Wave Barrier Project. WSDOT monitoring report, March 2006.

APPENDIX A– STEEL PILE WAVEFORM ANALYSIS FIGURES

PILE R4 – TNAP1 (HOLLOW WALLED CASING)

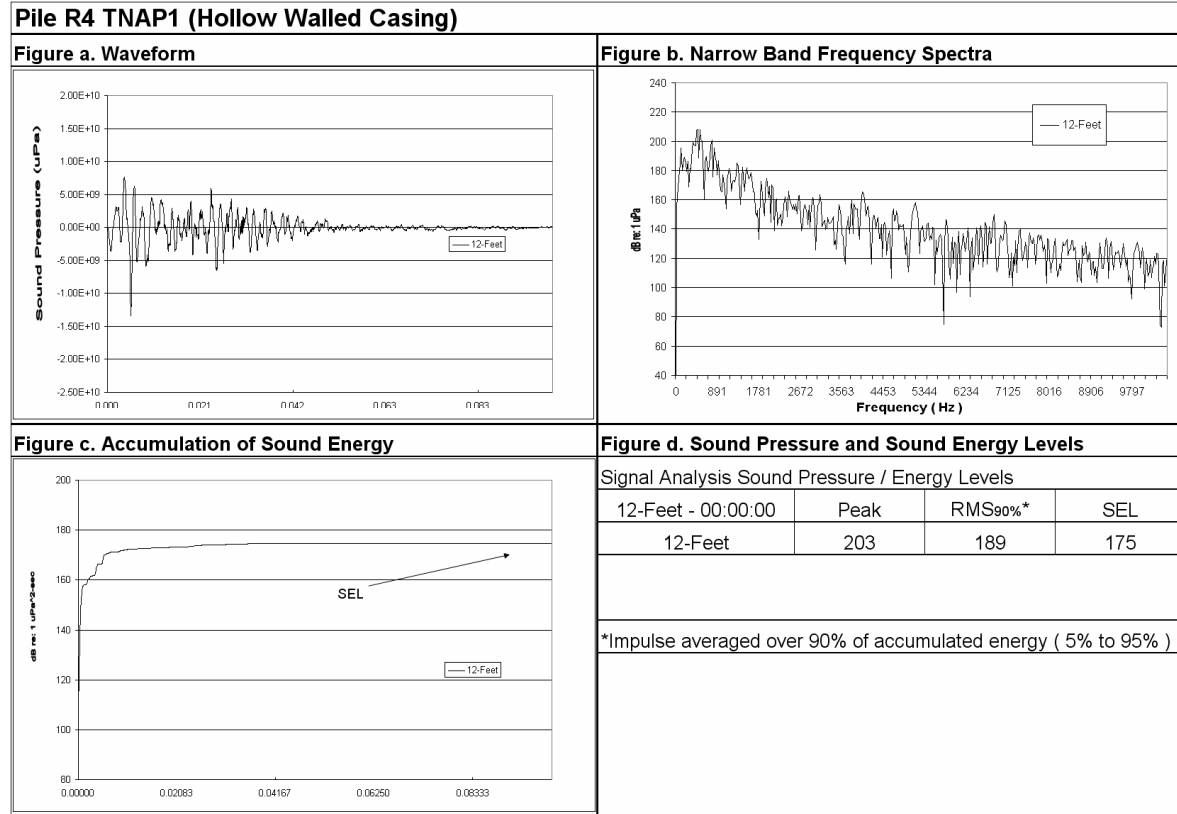

Figure 28: Waveform Analysis of Pile R4 Sound Pressure Levels with Temporary Noise Attenuation Pile 1 (TNAP1), Midwater.

Pile R4 TNAP1 (Hollow Walled Casing-Retest)

Figure a. Waveform

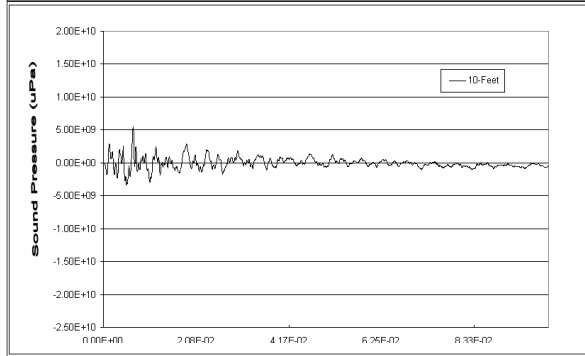

Figure b. Narrow Band Frequency Spectra

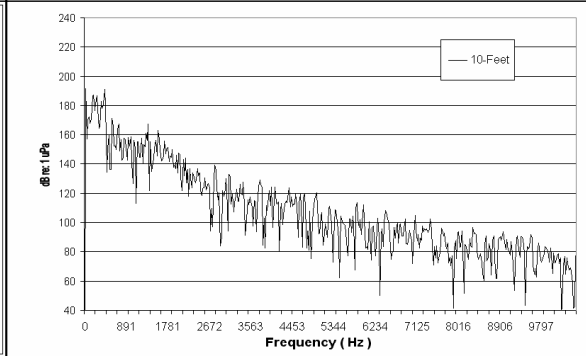

Figure c. Accumulation of Sound Energy

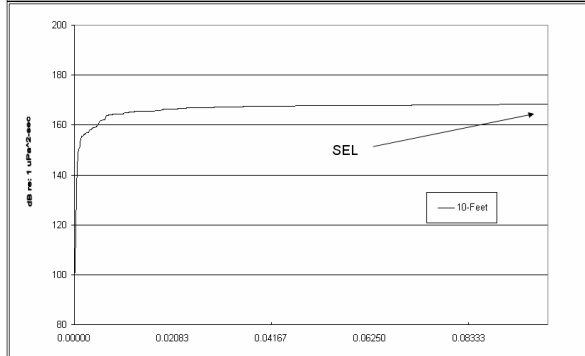

Figure d. Sound Pressure and Sound Energy Levels

Signal Analysis Sound Pressure / Energy Levels			
10-Feet - 00:00:00	Peak	RMS _{90%} *	SEL
10-Feet	195	179	168
*Impulse averaged over 90% of accumulated energy (5% to 95%)			

Figure 29: Waveform Analysis of Pile R4 Sound Pressure Levels with Temporary Noise Attenuation Pile 1 (TNAP1), Midwater

Pile R2 – Bubble Curtain Off

Figure 20a

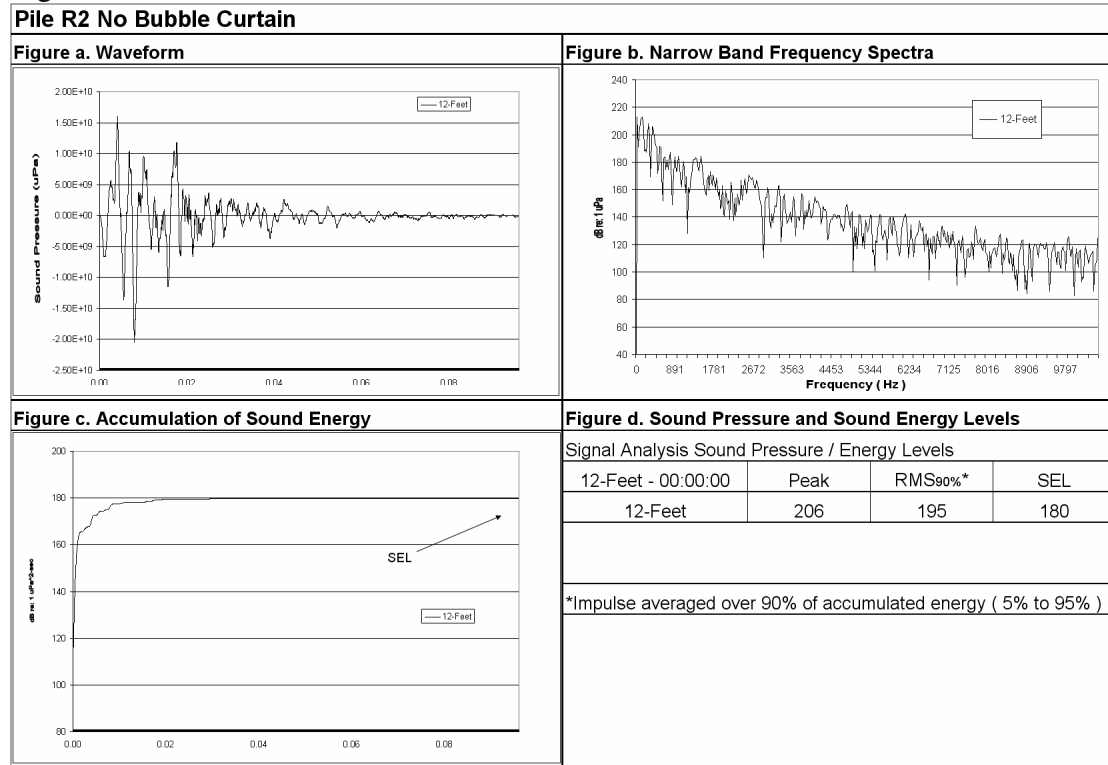

Figure 20b

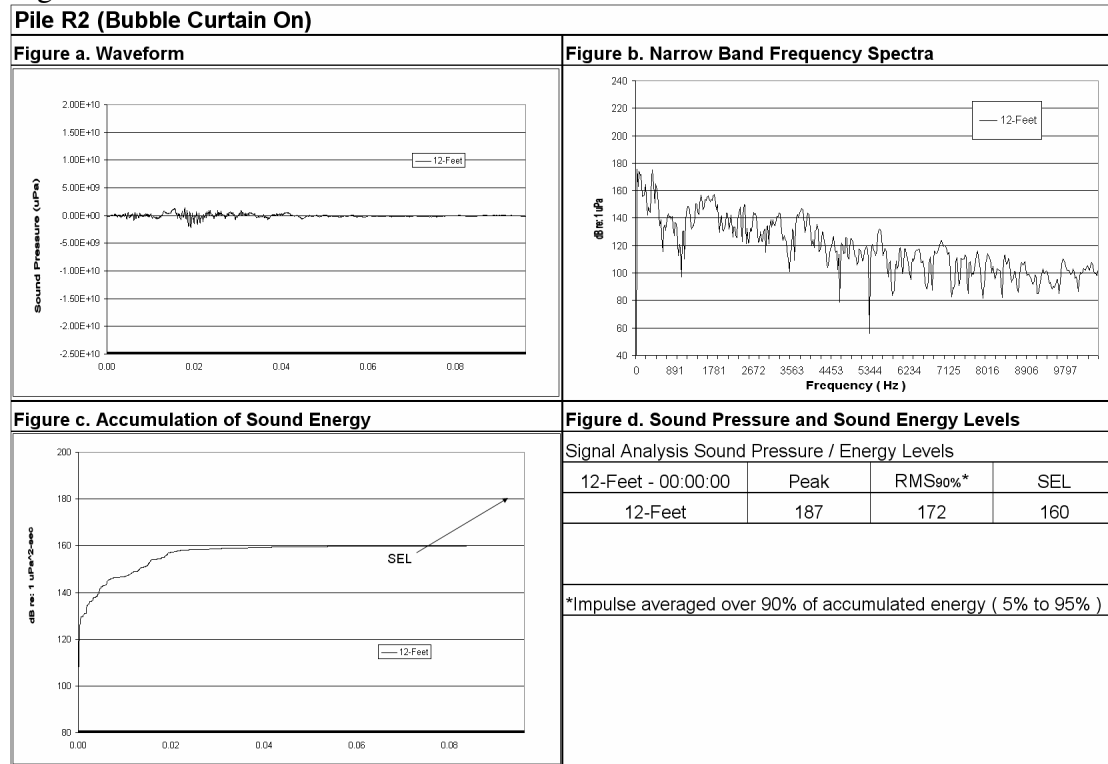

Figure 30: Waveform Analysis of Pile R2 Sound Pressure Levels with Bubble Curtain On (b) and Off (a), Midwater.

PILE R3 – TNAP2 (FOAM LINED STEEL CASING)

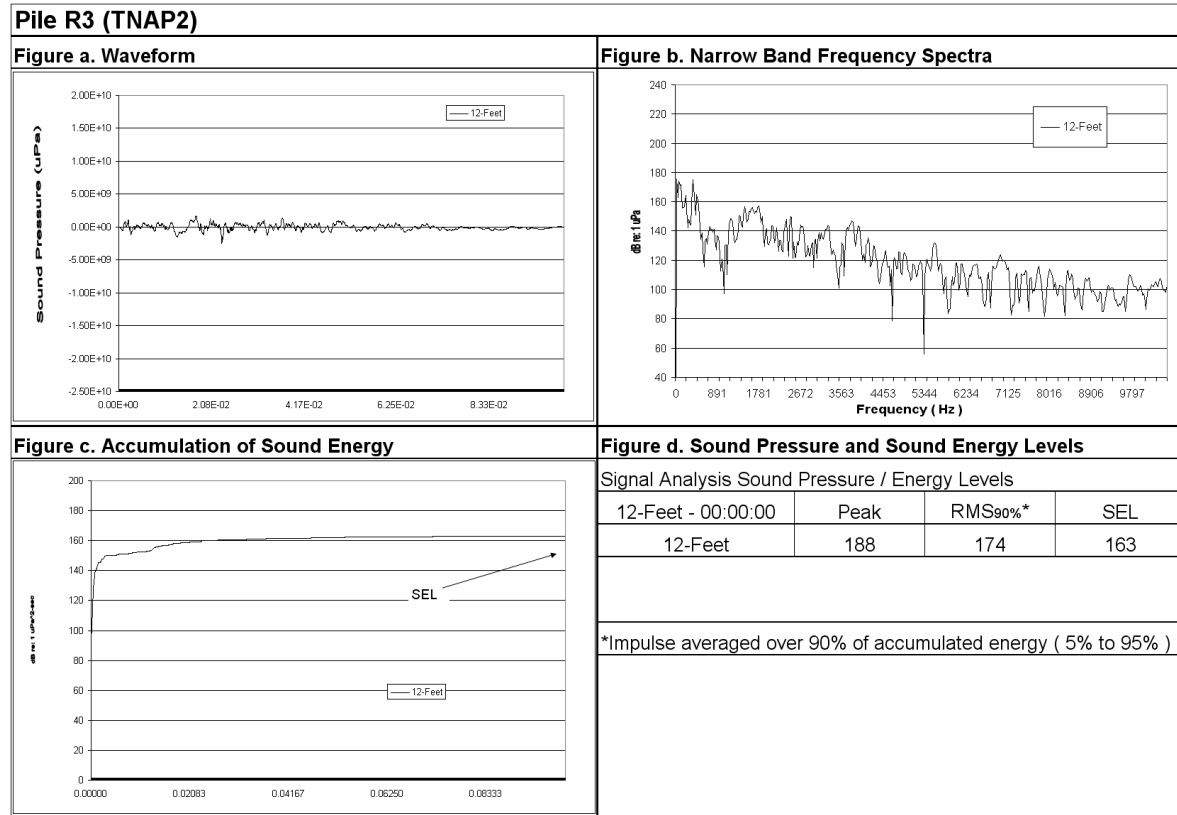

Figure 31: Waveform Analysis of Pile R3 Sound Pressure Levels with Temporary Noise Attenuation Pile 2 (TNAP2), Midwater.

PILE R1 – TNAP2

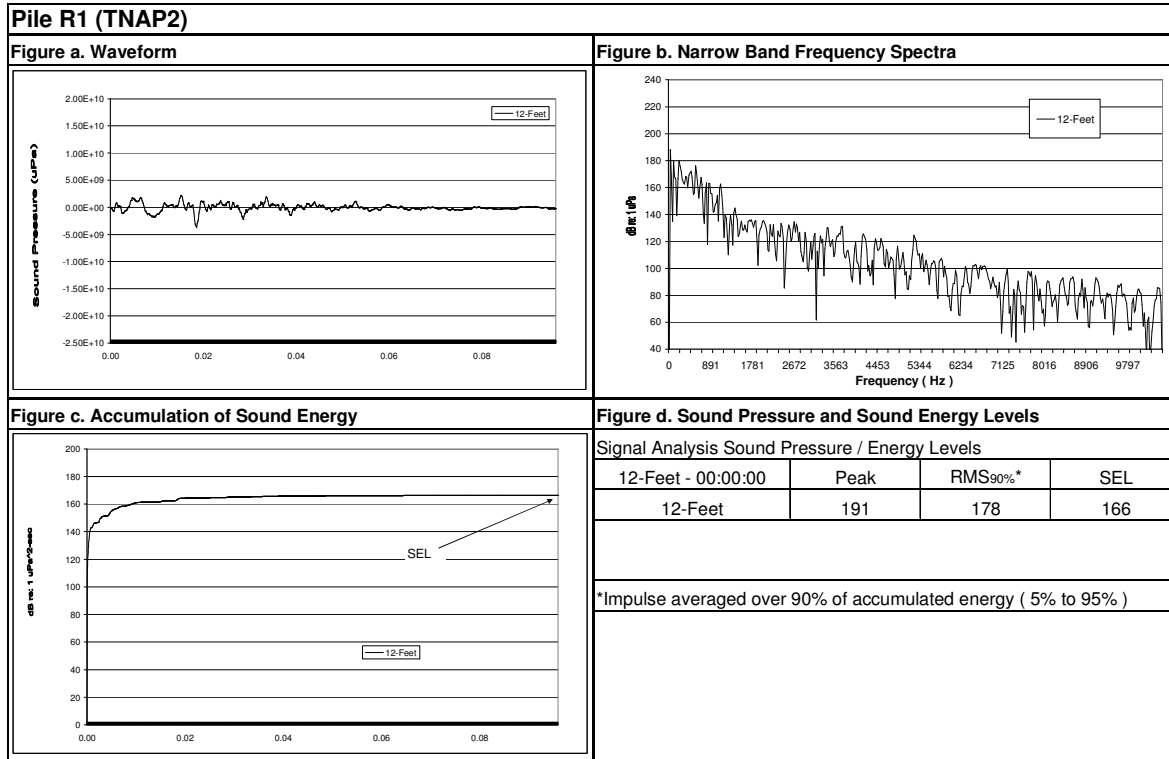

Figure 32: Waveform Analysis of Pile R1 Sound Pressure Levels with TNAP2, Midwater.

PILE T2 – BUBBLE CURTAIN

Figure 33a

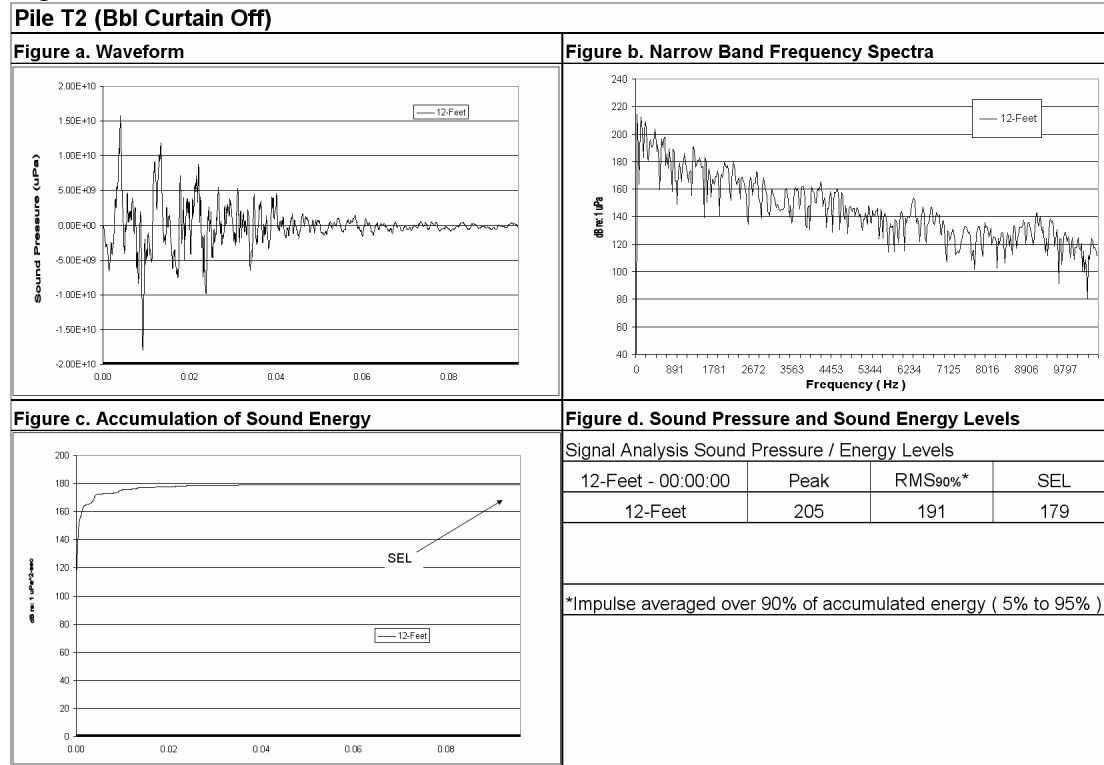

Figure 33b

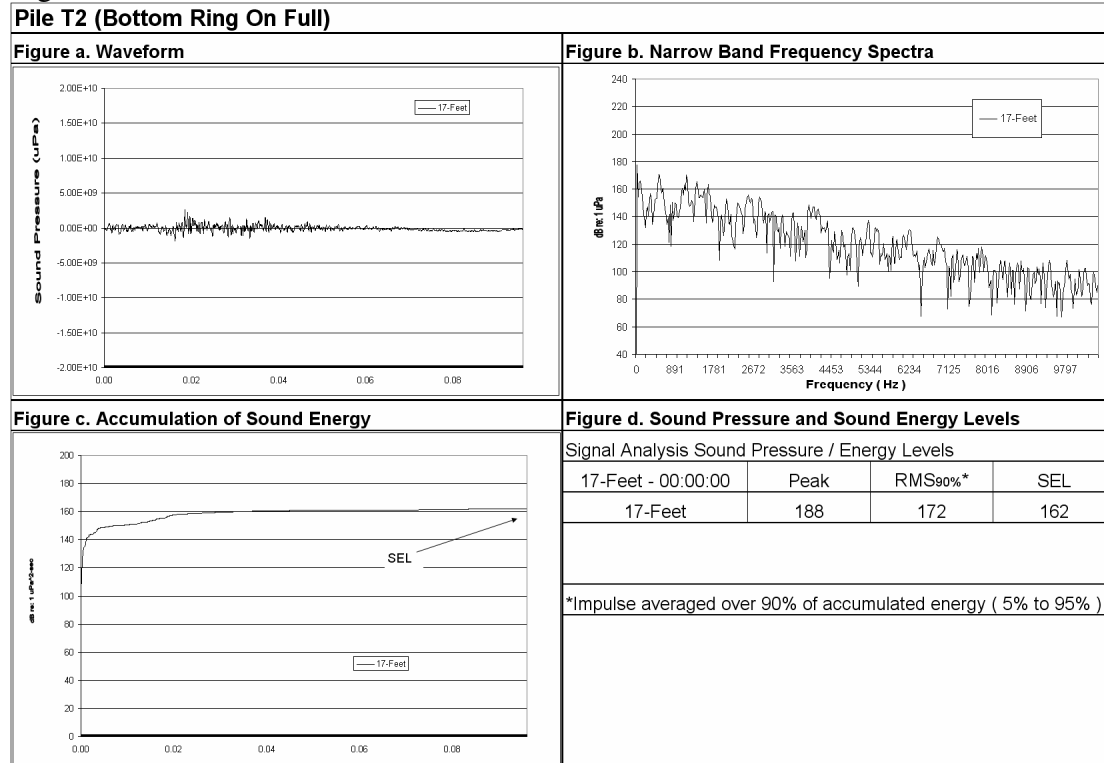

Figure 33c

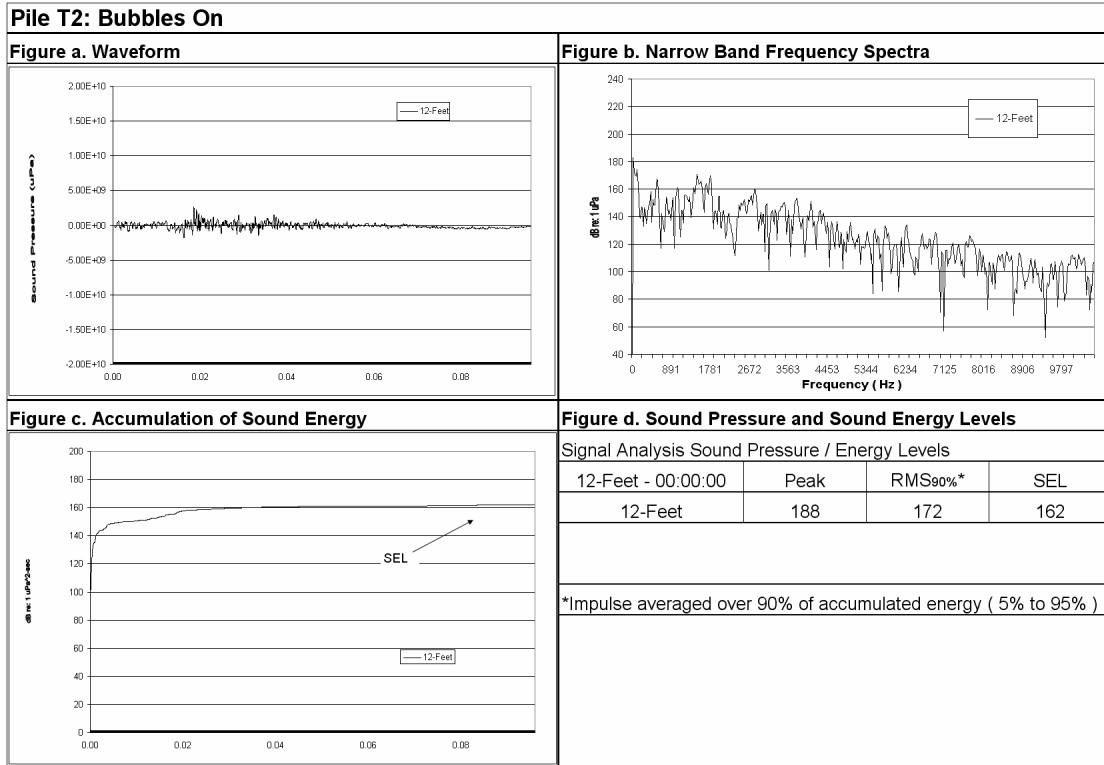

Figure 33: Waveform Analysis of Pile T2 Sound Pressure Levels with Bubble Curtain Off (a), Bottom Ring On Only (b), and Both Rings On (c), Midwater.

APPENDIX B– CONCRETE PILE WAVEFORM ANALYSIS FIGURES

PILE T1 – OCTAGONAL CONCRETE PILE (WITH 12-INCH WOOD PILE CAP)

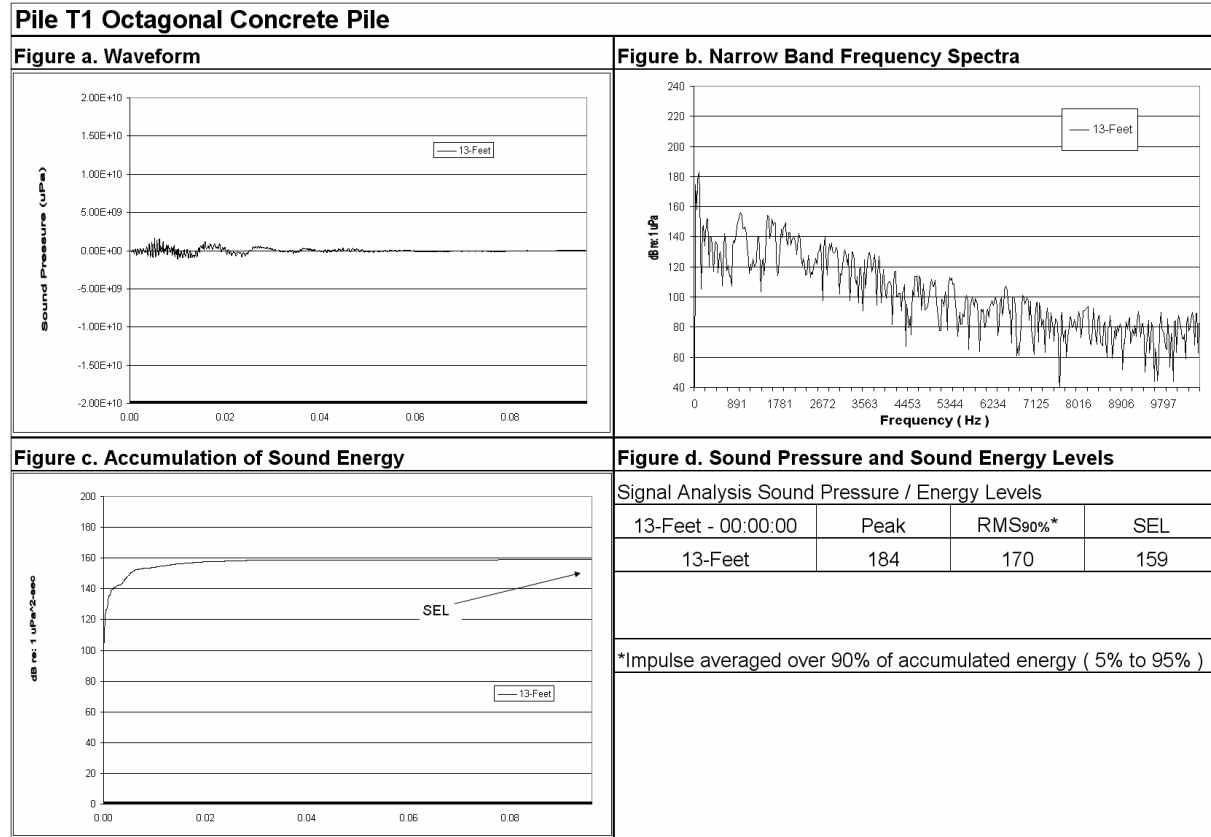

Figure 34: Waveform Analysis of Pile T1 Sound Pressure Levels of Octagonal Concrete Pile with 12-inch Wood Cap, Midwater.

PILE T3 – 36-INCH HOLLOW CONCRETE PILE (WITH 12-INCH WOOD PILE CAP)

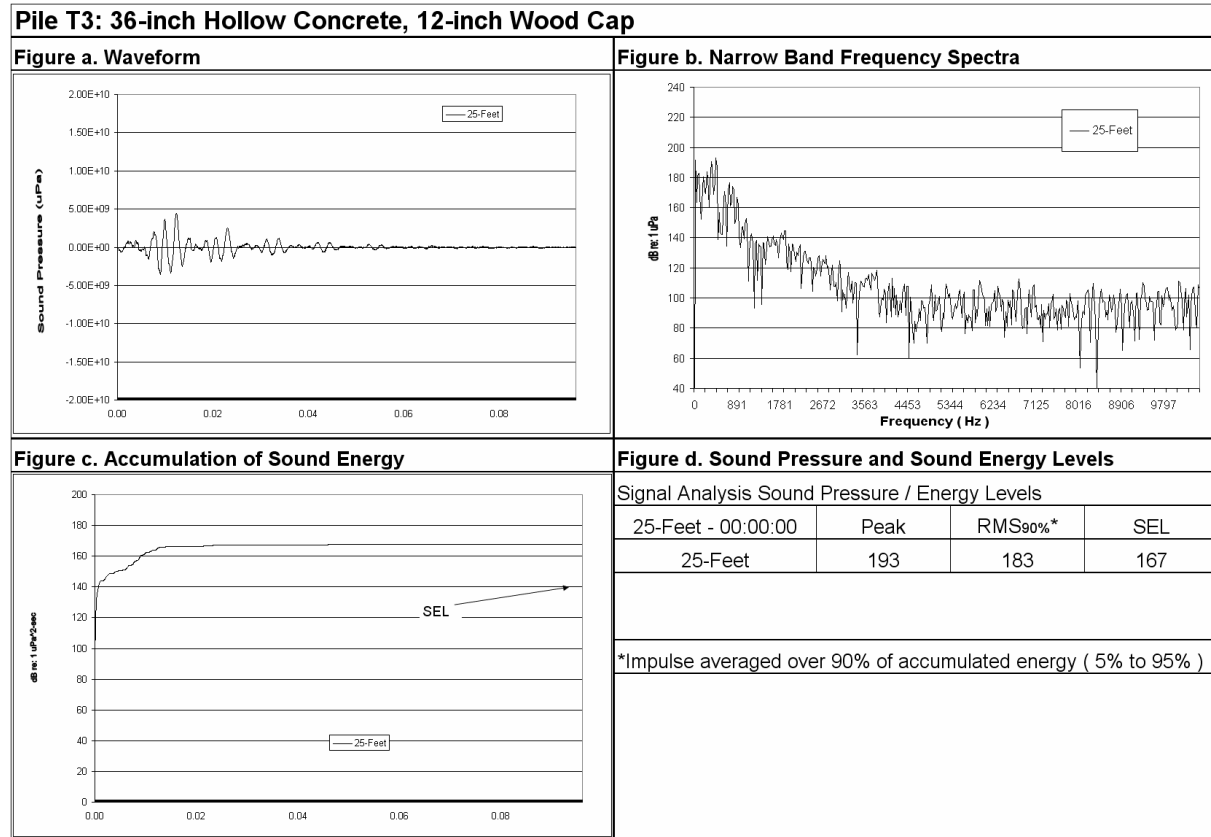

Figure 35: Waveform Analysis of Pile Number T3 Sound Pressure Levels of Hollow Concrete Pile with 12-inch Wood Cap, Midwater.

PILE T4 – 36-INCH HOLLOW CONCRETE PILE (WITH 12-INCH WOOD PILE CAP)

Figure 36 a

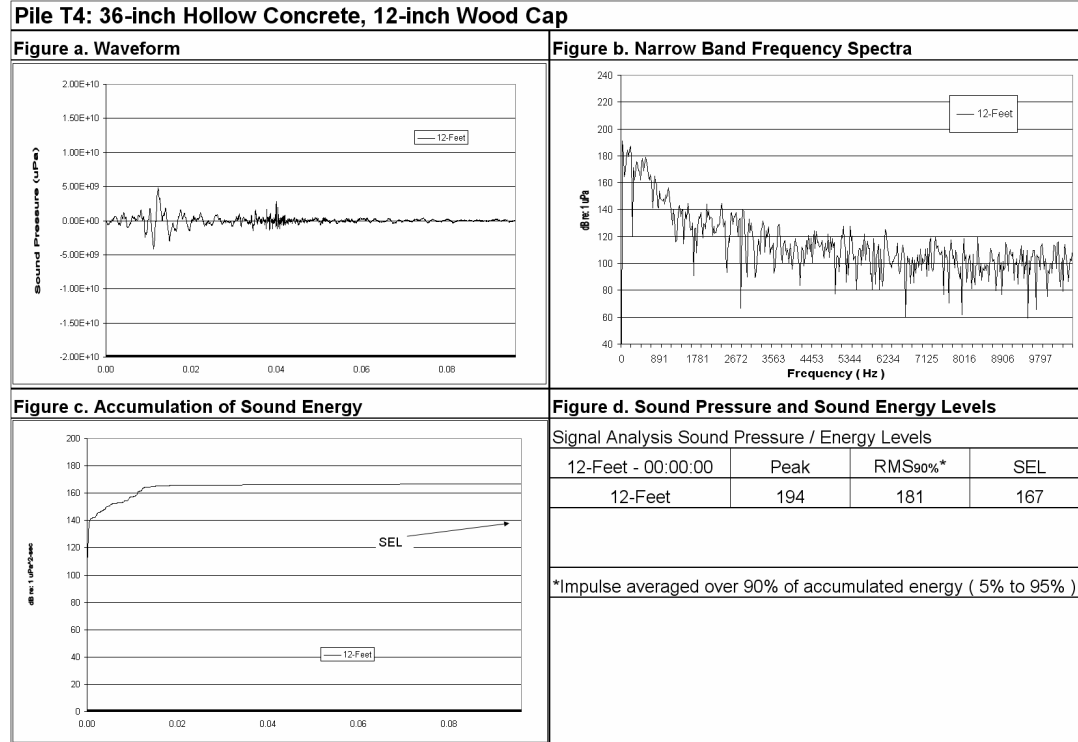

Figure 36b

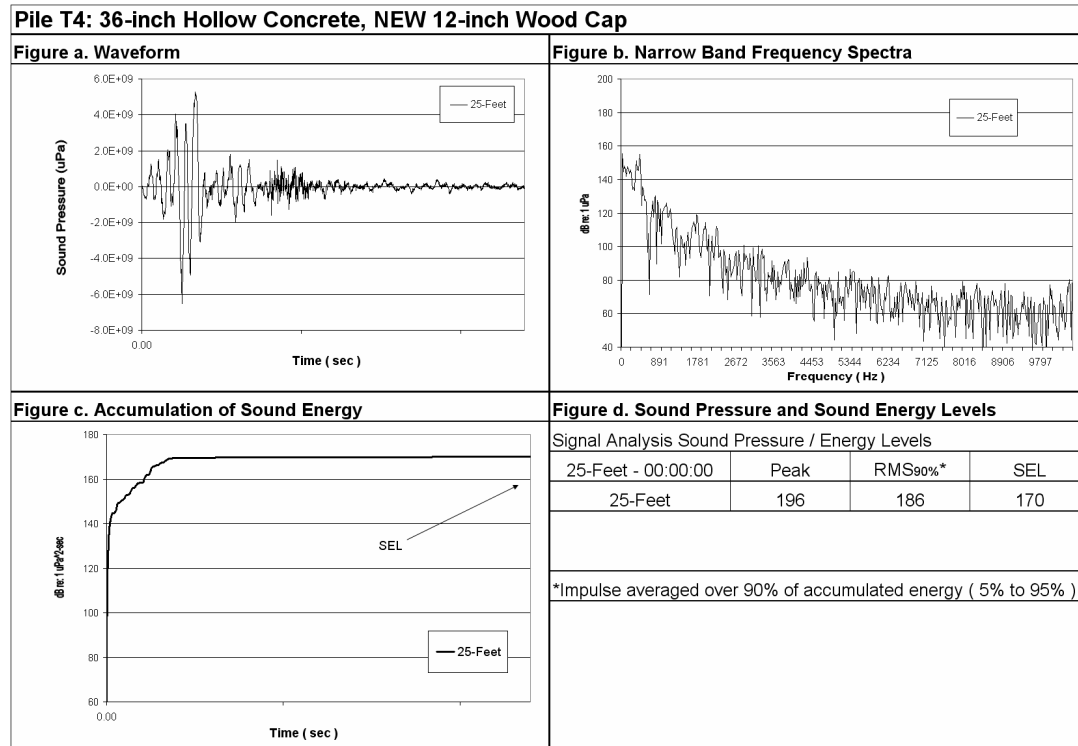

Figure 36: Waveform Analysis of Pile Number T4 Sound Pressure Levels of Hollow Concrete Pile with 12-inch Wood Cap, Midwater.