

USE AND CARE MANUAL

RENAISSANCE[®] 30-INCH GAS RANGE

For use with models ER30G and ER30GI

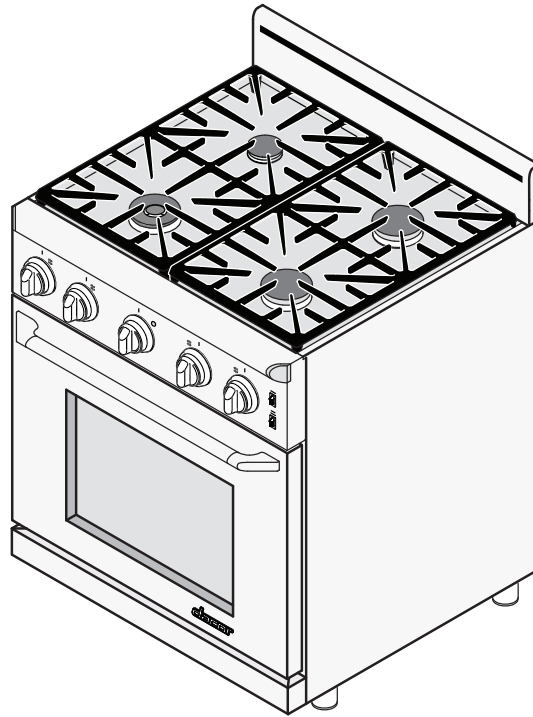
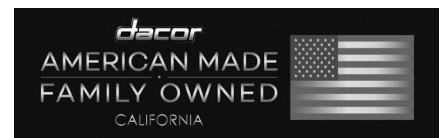

Table of Contents

Important Safety Instructions	1
Getting to Know Your Range	4
Setting Up Your Range	6
Operating Your Range	8
Care and Cleaning	14
Before You Call for Service	18
Warranty and Service	20
Warranty Card	Back Cover





To Our Valued Customer:

Congratulations on your purchase of the very latest in Dacor® products! Our unique combination of features, style and performance make us The Life of the Kitchen™, and a great addition to your home.

In order to familiarize yourself with the controls, functions and full potential of your new Distinctive Appliance, read this use and care manual thoroughly, beginning with the **Important Safety Instructions** section.

All Dacor appliances are designed and manufactured with quality and pride, while working within the framework of our company value. Should you ever experience a problem with your product, please first check the **Before You Call for Service** section of this manual for guidance. It provides useful suggestions and remedies prior to calling for service.

Valuable customer input helps us to continuously improve our products and services, so please feel free to contact our Customer Service Team for assistance with any of your product support needs.

Dacor Customer Service Team
14425 Clark Avenue
City of Industry, CA 91745

Telephone: (800) 793-0093
Fax: (626) 403-3130
Hours of Operation: Monday through Friday
6:00 A.M. to 5:00 P.M. Pacific Time
Web Site: www.dacor.com

Thank you for choosing Dacor for your home. We are a company built by families for families and we are dedicated to serving yours. We are confident that your new Dacor product will deliver a high level of performance and enjoyment for many years to come.

Sincerely,

The Dacor Customer Service Team

Important Safety Instructions

Installer: Leave these instructions with the appliance.

Consumer: Read this use and care manual completely before using this appliance. Save it for future reference.

For service and warranty information, see page 19.

If you have any questions, call:

Dacor Customer Service

(800) 793-0093 (U.S.A. and Canada)

Monday — Friday 6:00 A.M. to 5:00 P.M. Pacific Time

Web site: www.dacor.com

Have the model and serial number ready. See page 5 for serial number location. Write the serial number and purchase date below for reference.

Model number _____

Serial number _____

Date of purchase _____

Since Dacor continually improves the quality and performance of our products, we may make changes to the appliance without updating this manual. Visit www.dacor.com to download the latest version of this manual.

Important Information About Safety Instructions

The **Important Safety Instructions** and warnings in this manual are not meant to cover all possible problems and situations that can occur. Use common sense and caution when installing, maintaining or operating this or any other appliance.

Always contact the Dacor Customer Service Team about problems or situations that you do not understand.

Safety Symbols and Labels

DANGER

Immediate hazards that **WILL** result in severe personal injury or death.

WARNING

Hazards or unsafe practices that **COULD** result in severe personal injury or death.

CAUTION

Hazards or unsafe practices that **COULD** result in minor personal injury or property damage.

WARNING

IMPORTANT: If you smell gas:

- Do not use or light any appliance.
- Do not touch any electrical switch or use any electrical devices including the telephone in your building.
- From a neighbor's phone, immediately call the gas supplier. Follow the gas supplier's instructions.
- If you cannot contact the gas supplier, call the fire department.
- Do not return to the building until instructed to do so by the gas supplier or the fire department.

IMPORTANT: To avoid the possibility of explosion or fire, do not store or use combustible, flammable or explosive vapors and liquids (such as gasoline) inside or in the vicinity of this or any other appliance. Also keep items that could explode, such as aerosol cans away from the range. Do not store flammable or explosive materials in adjacent cabinets or areas.

WARNING

NEVER use this appliance as a space heater to heat or warm the room. Doing so may result in carbon monoxide poisoning and overheating of the appliance.

WARNING

NEVER block or cover any slots, holes or passages anywhere inside the oven or on the outside of the range. Doing so blocks airflow through the oven and cooktop and may cause carbon monoxide poisoning or fire. Keep all slots clear of grease and grime.

CALIFORNIA PROPOSITION 65 WARNING

The burning of gas cooking fuel generates some by-products that are on the list of substances which are known by the State of California to cause cancer or reproductive harm. California law requires businesses to warn customers of potential exposure to such substances. To minimize exposure to these substances, always operate this unit according to the use and care manual, ensuring you provide good ventilation when cooking with gas.

READ AND SAVE THESE INSTRUCTIONS

Important Safety Instructions

General Safety Precautions

To reduce the risk of fire, electric shock, serious injury or death when using your range, follow basic safety precautions, including the following:



WARNING

- If you receive a damaged product, immediately contact your dealer or builder. Do not install or use a damaged appliance.
- Make sure that the range has been properly installed by a qualified installer according to the accompanying installation instructions. Have the installer show you the location of the gas shut off valve and the electrical outlet so that you know where and how to turn off the gas supply and disconnect power to the range.
- Do not install, repair or replace any part of the range unless specifically recommended in the literature accompanying it. A qualified service technician should perform all other service.
- Before performing any type of service, make sure that the gas supply is off and the power cord to the range is disconnected.
- Only use this range for cooking tasks expected of a home appliance as outlined in this manual. This range is not intended for commercial use. This appliance is certified only for indoor use.
- **DO NOT TOUCH THE SURFACES OF THE RANGE DURING OR IMMEDIATELY AFTER USE.** After use, make sure these surfaces have had sufficient time to cool before touching them.
- In the interest of safety, keep the oven door shut unless inserting or removing food from the oven or when cleaning it.
- Do not operate the range without the backguard attached. A fire hazard may result.
- Make sure individuals who use the range are able to operate it properly.
- Never allow anyone, including children to sit, stand or climb on any part of the range. Doing so may cause damage, serious injury or death. Do not leave children alone or unattended in the area around the range. Do not allow children to play with the controls, pull on the handle or touch other parts of the range.
- Do not store items of interest to children on top of or above the range. Children could be burned or injured while climbing on the appliance.
- Do not attempt to use this appliance in the event of a power failure. If a power failure occurs while operating the cooktop, turn all control knobs to the **OFF** position.
- Do not tamper with the controls. Do not adjust or alter any part of the range unless specifically instructed to do so in these instructions.



WARNING

- Do not hang flammable or heat sensitive objects over the range.
- Do not cover the burners and grates with anything except properly selected utensils. Decorative covers may cause a fire hazard or damage to the cooktop if a burner is accidentally turned on with the cover in place.
- Do not heat unopened food containers such as baby food jars and cans. Pressure build up may cause the container to burst and cause injury.
- Keep flammable items, such as paper, cardboard, plastic and cloth away from the burners and other hot surfaces. Do not allow pot holders to touch hot surfaces or gas burners.
- Do not wear loose or hanging apparel while using the range. Do not allow clothing to come into contact with the range and surrounding areas during and immediately after use.
- Do not use towels or bulky cloth as pot holders.
- Use only dry pot holders when removing food and cookware from the cooktop or oven. Wet pot holders can cause steam burns.
- If the range is near a window, do not use long curtains as window treatment. The curtains could blow over the cooktop and create a fire hazard.
- To avoid the possibility of fire, do not leave the range unattended when in use.
- Clean the range thoroughly before operating it for the first time.
- Clean and maintain the range regularly as instructed in the **Care and Cleaning** section of this manual. Keep the entire range, ventilation filters and range hoods free of grease that could catch fire.
- Use cookware only for its intended purpose. Check the manufacturer's recommendations before use to determine if a utensil is suitable for use with a range. Certain types of glass, ceramic and earthenware are not suitable for use with a range. Personal injury or damage may result from the improper use of cookware.
- Select cookware carefully. Use utensils of the proper size, material and construction for the particular type of cooking being done. Utensils need to be large enough to contain the desired quantity of food without boil-overs or spill-overs. Choose pans with easy to hold handles that will stay cool while cooking. Do not use utensils with loose handles. Avoid using pans that are too heavy to lift safely.

Important Safety Instructions

WARNING

- Make sure that all the cooktop parts are dry before lighting a burner.
- Turn the knobs to the **OFF** position prior to removing them from the valve stems.
- Do not use the oven for storage.
- Exercise caution when opening the oven door. Let hot air or steam escape before looking or reaching into the oven.
- The cooktop should never be operated without the knobs or trim rings in place.
- For your safety, do not use the oven to cook without the convection filter(s) installed. When the filter is not installed, the spinning fan blades at the back of the oven are exposed.
- Do not allow food to sit in the oven for more than one hour before or after cooking. Eating spoiled food can result in food poisoning.
- Non-stick coatings, when heated, can be harmful to birds. Remove birds to a separate, well-ventilated room during cooking.
- When deep fat frying:
 - ◇ Be certain that the pan is large enough to contain the desired volume of food without overflow caused by the bubbling of the fat. Never leave a deep fat fryer unattended.
 - ◇ Avoid frying moist or frost-covered foods. Foods with high water content may cause spattering or spilling of the hot fat.
 - ◇ Heat fat slowly, and stir together any combination of oils and fats prior to applying heat. Utilize a deep fat frying thermometer to avoid heating the fat to temperatures above the flash point.

TO REDUCE THE RISK OF INJURY TO PERSONS IN THE EVENT OF A RANGE TOP GREASE FIRE:

- a. **SMOTHER FLAMES** with a close-fitting lid, cookie sheet or metal tray, then turn off the burner. **BE CAREFUL TO PREVENT BURNS.** If the flames do not go out immediately, **EVACUATE AND CALL THE FIRE DEPARTMENT.**
- b. **NEVER PICK UP A FLAMING PAN** - you may be burned.
- c. **DO NOT USE WATER**, including wet dish cloths or towels - a violent steam explosion may result.
- d. Use a fire extinguisher **ONLY** if:
 - ◇ You have a Class ABC extinguisher, and you already know how to operate it.
 - ◇ The fire is small and contained in the area where it started.
 - ◇ The fire department is being called.

WARNING

- Use extreme caution if adding water to food on a hot cooktop or oven. The steam can cause serious burns or scalds.

- This appliance is equipped with a three-prong grounding plug for your protection against possible electric shock hazards.

If only a two-prong outlet is available, it is the customer's responsibility to have it replaced with a dedicated, grounded three-prong electrical outlet by a licensed electrician. **Do not under any circumstances:**

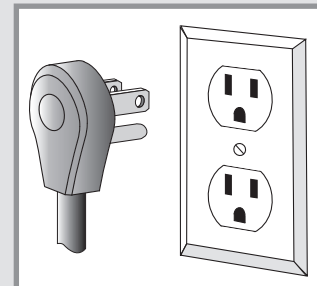

- ◇ Cut or remove the third (ground) prong from the power cord.
- ◇ Use an adapter plug.
- ◇ Use an extension cord.
- ◇ Use a power cord that is frayed or damaged.
- ◇ Plug the cooktop into an electrical outlet with a ground fault interrupter (GFI).
- ◇ You can fight the fire with your back to an exit.

CAUTION

- Do not allow acids (citrus juices, tomato sauces, etc.) to remain on the range's surfaces. The porcelain finish may stain.
- Never use the cooktop surface as a cutting board.
- Do not expose the knobs or trim rings to direct flame, hot utensils or other sources of heat.
- Always ensure that the light fixture lens cover is in place when using the oven. The lens cover protects the light bulb from breakage caused by high oven temperatures or mechanical shock.

Getting to Know Your Range

Parts of the Cooktop

BACKGUARD: Model ER30G comes standard with a six inch backguard installed. Model ER30GI comes standard with a low profile (1 3/4" inch) backguard. The backguard protects the wall from the effects of heat and splattering grease. Optional kits are available to change the size of the backguard for both models. See the **Accessories** section.

SPILL TRAY: The spill tray catches any food that falls through the cooktop grates.

GRATES: The porcelain coated cast iron grates support the cooking utensils during cooking. They are removable to allow the area below and around the burners to be cleaned easily.

BURNERS: See below for the size and location of the different burners. The range generates a spark to light the burner when you turn the knob to the **HIGH** position.

BURNER CONTROL KNOBS: Use the knobs to turn on the burners and adjust the flame size. The corresponding knob illuminates when a burner is on. The center knob operates the oven.

TRIM RINGS: Located behind each knob, they prevent liquids from getting into the internal parts.

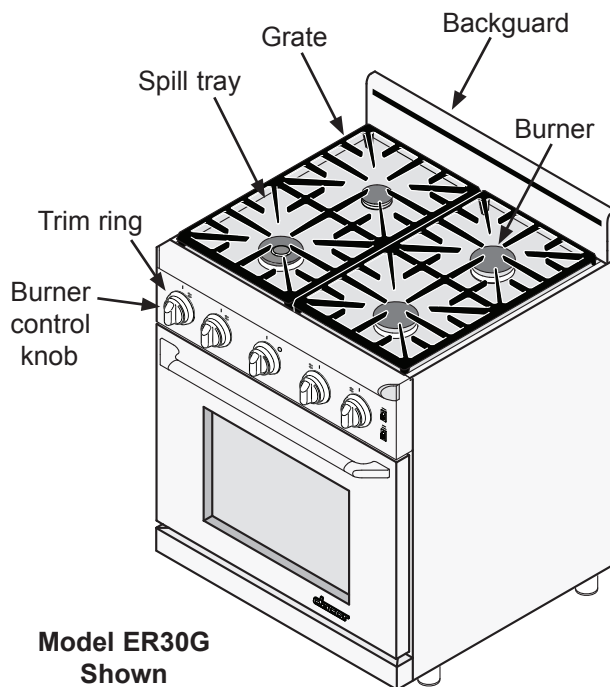

Model ER30G
Shown

Model ER30G (freestanding model) is equipped with full size stainless steel side panels. Model ER30GI is equipped with three inch deep side panels. It is designed for installation in a recessed cabinet or island.

Burner Locations and Features

- A. 1300 to 9500 BTU standard burner
- B. 1700 to 15000 BTU standard burner
- C. 800 to 18000 BTU dual burner

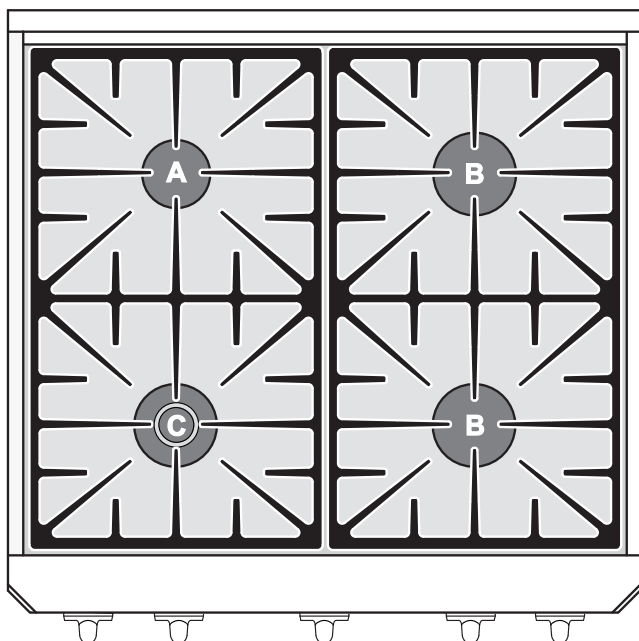

Special Cooktop Features

Perma-Flame™: The Perma-Flame instant re-ignition feature automatically re-lights a burner quickly if it goes out. With Perma-Flame, your cooking experience is uninterrupted because the flame is re-ignited at the same level as when it went out.

Smart Flame™: Smart Flame technology reduces the temperature under the fingers of the porcelain-coated cast iron grates. Smart-Flame extends grate life and protects the finish.

SimmerSear™: The dual burner is equipped with Dacor's exclusive precision burner control system. It allows you to cook with a wide range of heat settings, from simmer to sear.

Getting to Know Your Range

Parts of the Oven

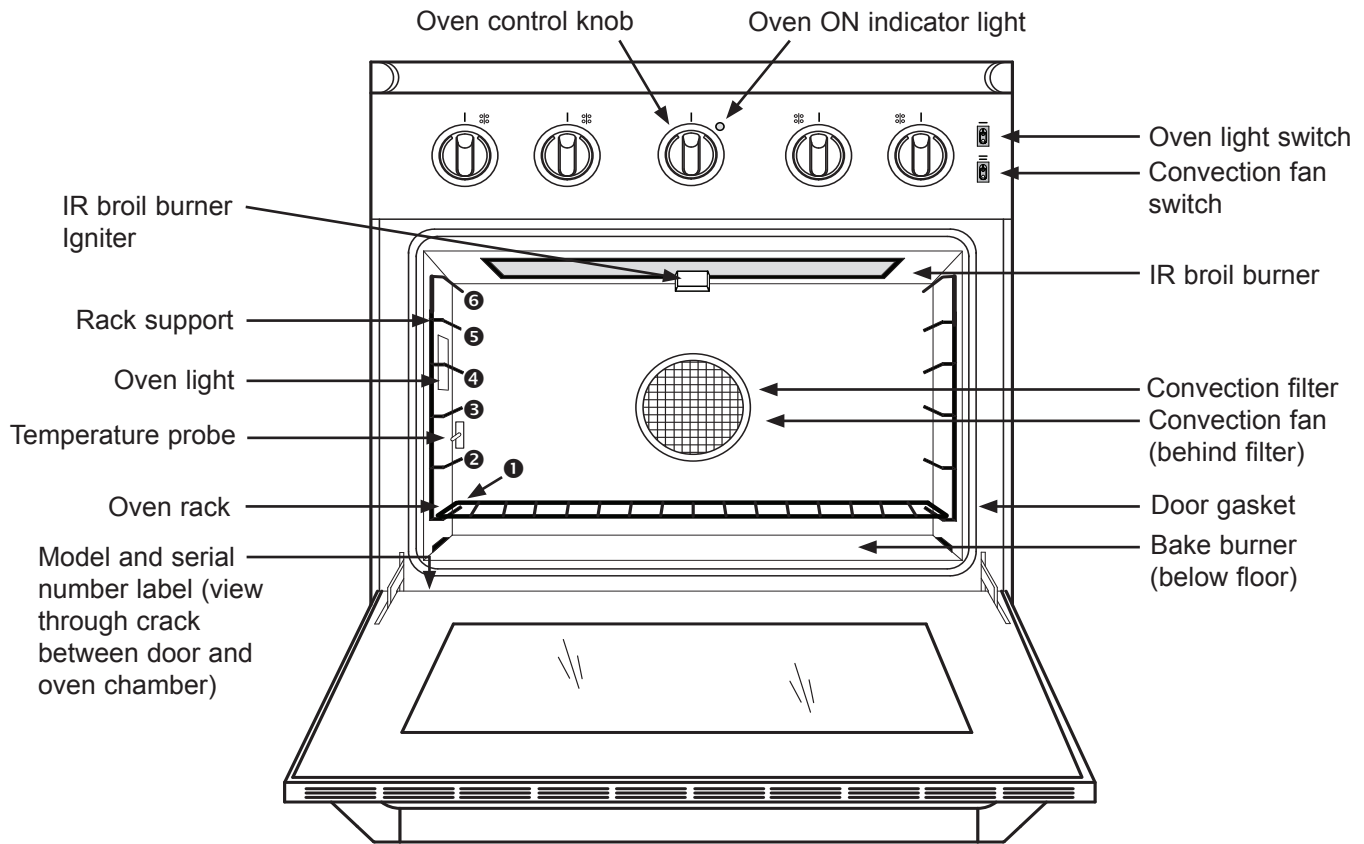

OVEN RACKS: Each oven comes with three chrome-plated adjustable oven racks.

RACK SUPPORTS: There are six rack positions inside the oven chamber. The rack positions are numbered from the bottom counting up.

OVEN CONTROL KNOB: Located in the center. Use the oven control knob to turn on the oven. One knob is used to control both the bake and broil burners. It lights when the oven is on.

BAKE BURNER: Located below the floor of the oven. It is the source of bottom heat.

CERAMIC INFRARED (IR) BROIL BURNER: The infrared broil burner is the source of top heat. It is mounted in the oven ceiling.

IR BROIL BURNER IGNITER: The igniter lights the broil burner when broiling. It normally glows orange from time to time during broil operation.

OVEN ON INDICATOR LIGHT: The oven ON indicator light illuminates when the oven is on. The light cycles on and off during normal use indicating that the oven's burner control system is maintaining a constant temperature. **NOTE:** When the power plug is first connected, reconnected or after a power outage, this light flashes on and off for about ten seconds while the range's circuitry starts up. The range is ready to use when the light stops flashing.

DOOR GASKET: The door gasket prevents heat from escaping when the door is closed.

TEMPERATURE PROBE: The temperature probe monitors the temperature inside the oven for the oven's burner control system. To prevent improper operation, do not cover it or do anything to damage it.

CONVECTION FAN: The convection fan circulates heated air through the oven chamber during the convection cooking process. The convection filter covers it. The **CONVECTION FAN SWITCH**, on the right side of the control panel, turns the convection fan on and off.

CONVECTION FILTER: The convection filter covers the convection fan. It helps prevent the transfer of taste from one food to another when you are cooking a whole meal with the convection fan in use. It also keeps the oven cleaner, especially when convection baking or convection broiling. In addition, it covers the moving convection fan blades for safety purposes.

OVEN LIGHT: The oven light is located behind the left oven rack supports. The light turns on or off only when you flip the **LIGHT SWITCH** on the front of the control panel. The bulbs are 12 Vac, 20 Watt, halogen.

Setting Up Your Range

Cooktop Assembly

The burner rings spread the flame evenly around the burner cap. All burner parts must be properly seated for proper burner lighting and operation.

To assemble the burners:

1. Remove the burner rings, burner caps and grates from their shipping packages.
2. Install the burners as shown below. Gently twist each piece back and forth after installation to make sure it is properly seated. A small gap below the burner ring is normal when installed properly.
3. Gently set the grates on top of the spill tray. Put the legs of each grate inside the corresponding dimples.

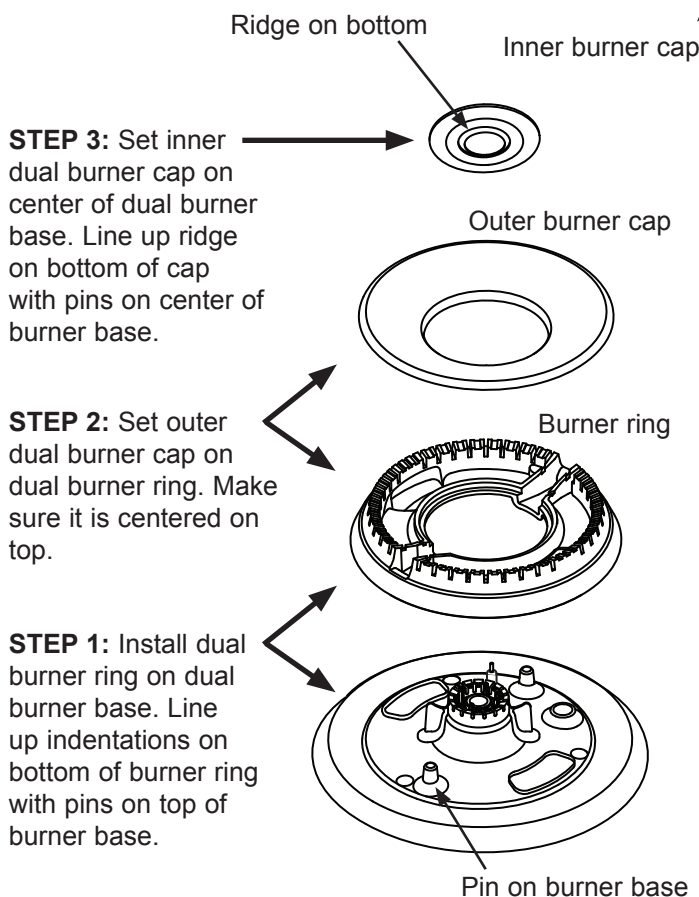
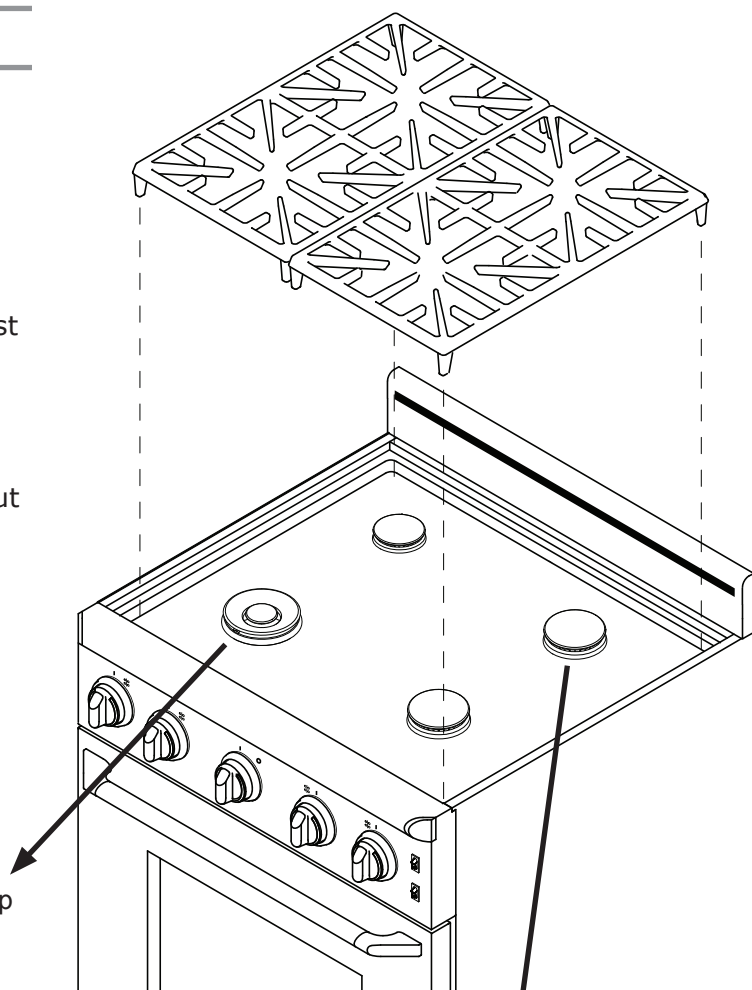

Dual Burner Assembly
(left front burner only)

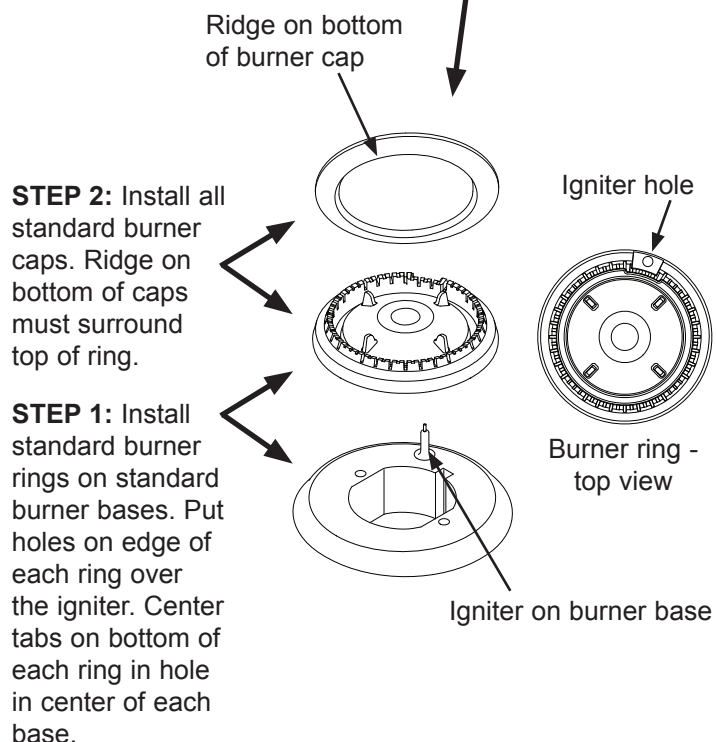

Standard Burner Assembly
(left rear, right front, right rear, burners)

Setting Up Your Range

Installing the Oven Racks

WARNING

The oven racks become hot when the oven is in use.

The rack supports provide six heights for positioning of the oven racks.

Three chrome-plated oven racks are provided. Always remember to position the racks prior to heating the oven.

To install a standard oven rack:

1. Insert the end of the rack with the safety notches into the oven first.
2. Attach both sides of the rack to the rack supports in the oven as shown in the diagram below.
3. Begin to slide the rack in, and then, lift up so that the safety notches clear the ends of the rack supports.
4. Push the rack all the way in with both hands.

To remove a standard oven rack:

1. Grasp it with both hands and pull gently straight out toward you until it stops.
2. To remove the rack completely, lift the front of the rack up about six inches and continue to pull it out. Lifting the rack releases the safety notches. The safety notches reduce the chances of a rack coming out of the oven accidentally.

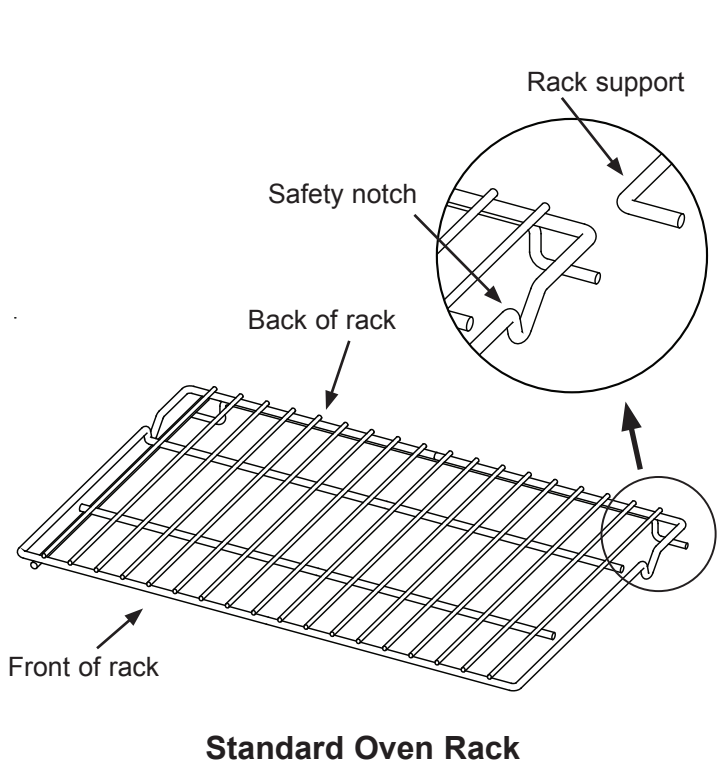

To Insert a GlideRack™ Oven Rack:

Your oven comes with Dacor GlideRack oven racks. When you use them, you can effortlessly slide heavy pots, pans or other items out of the oven to check, stir or add ingredients quickly and safely.

1. Extend both rack guides completely as shown below.
2. Align the safety clips (right and left) on the back of the rack guides with the oven rack supports as shown.
3. Insert the rack into the oven, sliding the rack supports between the rear safety clips as shown. As you slide it in, hold the front of the rack up slightly until the front safety clips just clear the front of the rack supports.
4. Lower the front of the rack so that the front of the rack support is between the front safety clip and the rack stop.
5. Grasp the rack in the front center and pull. The rack should come forward while the guides remain in place.

To Remove Your GlideRack Oven Rack:

1. Grasp the rack with both hands and pull it gently straight out toward you until it stops.
2. Lift up until the front safety clips just clear the front of the rack supports on the oven. Continue to pull out. Moving the end of the rack back and forth slightly, left to right, as you pull, will make it easier to remove.

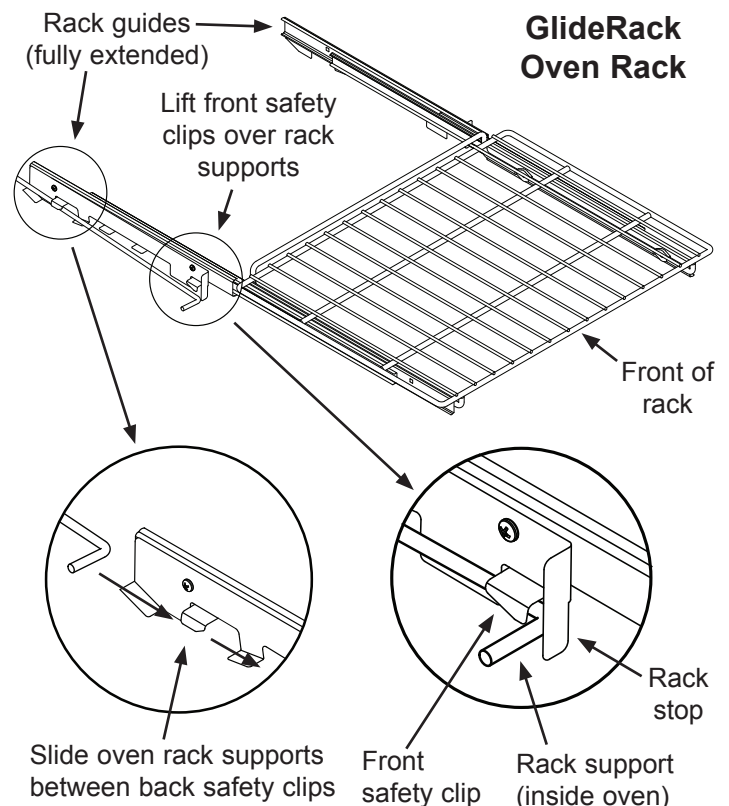

Operating Your Range

Burning-in the Oven

When the oven comes from the factory, residue for certain materials used in the manufacturing process are left on the parts of the oven. These residues should be “burned off” before the oven is used for the first time.

To burn off the residues in the oven:

1. Birds or other small pets may be sensitive to the odors during first operation. Remove them to another part of the house and close the door.
2. Open windows and turn on the range hood to allow the odors and smoke to escape.
3. Turn the oven to the **BROIL** setting for 10 minutes. It is normal for odors and smoke to come out of the vent slot on the backguard during this process.
4. After ten minutes, turn the oven control knob down to 350°F. Leave the oven at 350°F for 30 minutes.
5. After 30 minutes, turn off the oven. Close the windows and turn off the range hood when the odors and smoke finish clearing.

Things to Know Before Using the Cooktop

- A normal flame is steady and blue in color. Foreign material in the gas line, especially in new construction, may cause an orange flame during initial operation. This color will disappear with further use. Small yellow tips on the ends of the flames are normal when using LP gas.
- See page 4 for the heat ranges of the different burners.
- Food cooks just as quickly at a gentle boil as it does at a vigorous, rolling boil. Maintaining a higher boil than necessary wastes energy and cooks moisture, food flavor, and nutrients out of the food.
- Use a low or medium flame when cooking with utensils that are poor conductors of heat, such as glass, ceramic or cast iron. Reduce the flame until it covers approximately 1/3 of the utensil diameter. Doing so will ensure even heating and reduce the likelihood of burning or scorching the food.
- Dacor’s SimmerSear feature allows you precision control of the flame on the dual burner, from low to high heat.

Cooktop Operation

WARNING

- To avoid the chance of fire, explosion or carbon monoxide poisoning, do not attempt to use your range without the burners completely and properly assembled (see page 6). The burner rings must be properly seated for proper burner lighting and operation.
- To avoid burns and scalding, always turn pan handles to a position where they cannot be easily hit. Also, handles should not extend over adjacent burners. Always set utensils gently onto the grates and center them so that they are well-balanced.
- Do not drag cookware across the grates. Sliding may damage the finish. Lift utensils to reposition them. Do not drop them on the grate.
- Cookware with rough bottoms can cause permanent damage to the coated surfaces on the grates.
- To avoid burns or fire hazard, reduce the flame level if it extends beyond the bottom of the utensil. A flame that extends up the sides of the utensil is potentially dangerous.

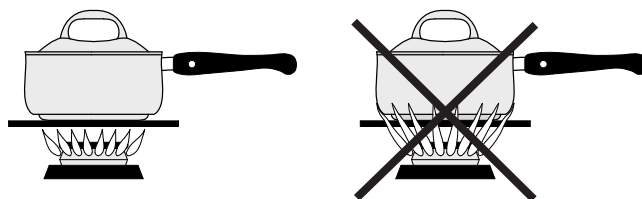

- In the interest of safety, always light the burner before putting the cooking utensil on the grate. Turn the burner knob to the **OFF** position before removing the utensil. Always check all the burner knobs to make sure the range is **OFF** when you are finished cooking.
- Do not turn the knob farther than the **HIGH** position until lit. Doing so may result in a burst of flame that could cause burns or damage to the surrounding area.
- Do not touch any part of the burner while the igniter is sparking. An electric shock could result.
- Never light the burners with a match or other open flame.
- If the gas does not ignite after four seconds or if the flame goes out and gas escapes, turn the knob to the **OFF** position. Open a window and allow at least five minutes for the gas to dissipate. Repeat the lighting procedure.

Operating Your Range

Selecting the Cookware

For overall safety and best performance, select the correct cooking utensil for the food being cooked. Improperly selected cooking utensils will not cook evenly or efficiently.

Use cookware that:

- Has flat, smooth bottoms.
- Is well balanced.

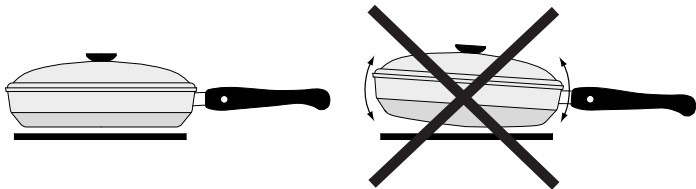

- Has tight fitting lids to keep heat, odors and steam in.

IMPORTANT: Avoid spills as much as possible. The porcelain surfaces of the grates, spill trays and burner caps are acid-resistant but not acid-proof. Some foods can cause permanent damage if allowed to remain on porcelain surfaces.

Lighting a Burner

Each burner control knob has a small diagram next to it to tell you which burner it operates.



1. Push in on the knob and turn it counter-clockwise to the **HIGH** position. The knob will illuminate and the igniter for the burner will spark repeatedly until it lights. The spark makes a "clicking" sound. The burner should light within four seconds. The flame should burn evenly around the perimeter of the burner, except underneath each grate support finger, where the flame height is reduced by Dacor's Smart Flame feature.

If the gas does not ignite after four seconds or if the flame goes out and gas escapes, turn the knob to the **OFF** position. Open a window and allow at least two minutes for the gas to dissipate. Repeat the lighting procedure.

If a burner still does not ignite, the igniter continues to spark or if the flame is not spread evenly around the burner cap, see the **Before You Call for Service** section on page 18.

2. Place the cooking utensil on the grate.
3. Adjust the flame to the level necessary to perform the desired cooking process.

IMPORTANT: When the cooktop is cool, the igniter may continue to spark if the control knob is set to the low position. The burner will stop sparking when warm. The tendency to spark when cold can be reduced by operating the burner at a higher flame setting for about 60 seconds. After 60 seconds, lower the flame to cook. The burner will also warm up faster if a utensil is placed on the grate. The igniter will also spark automatically if the flame is distorted by a draft or by the household ventilation system. Eliminate any drafts or reduce the ventilation blower speed to reduce this type of problem.

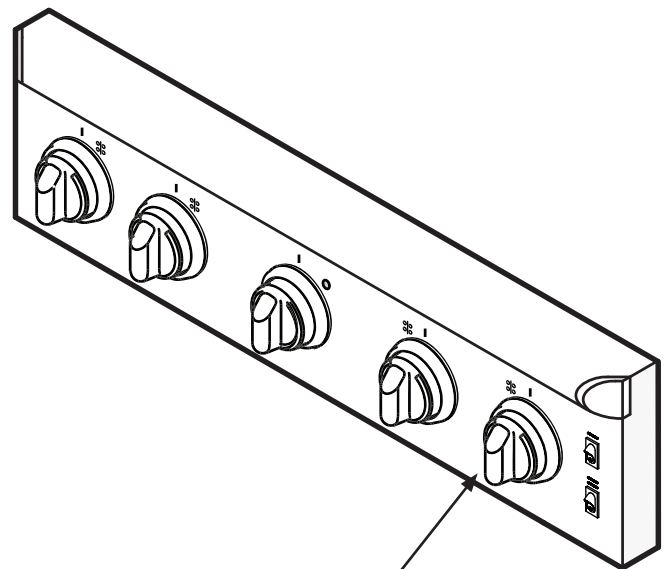

Burner knob symbols

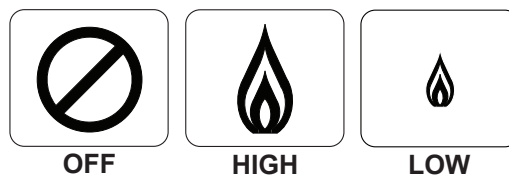

OR



Operating Your Range

Basic Oven Operation

You may use your oven to cook in one of the following modes:

❖ Bake

The bake process uses the bottom oven burner to provide conventional baking heat. Temperatures may be set from 125°F to 500°F. Use the standard bake mode for single rack baking.

❖ Convection Bake

The convection bake process uses the standard bake burner in combination with the convection fan to circulate heated air evenly throughout the oven chamber. Temperatures may be set from 125°F to 500°F. This type of baking is good for single rack baking in a deep pan, multiple rack baking and roasting.

❖ Broil

The ceramic infrared (IR) gas burner on the oven ceiling supplies the heat from the top for broiling. Good for grilling smaller cuts of meat and toasting breads. Broiling is always performed with the door closed.

❖ Convection Broil

The convection broil process uses the (IR) gas burner in combination with the convection fan for better heat distribution. Convection broil is good for items that do not need to be flipped such as thinner cuts of meat, fish and garlic bread. Convection broiling is always performed with the door closed.

WARNING

In broil and convection broil modes, high temperatures (up to 555°F) are present inside the oven. **To avoid the possibility of burns:**

- Broil only with the oven door completely shut.
- After turning the oven knob to **BROIL**, immediately place the food in the oven and shut the door completely.

WARNING

Broiling is a quick cooking process (20 minutes maximum). The range is designed for consumer use conditions only. Do not use it to broil continuously for more than 45 minutes at a time. After 45 minutes in broil mode, turn the oven off and allow it to cool for 30 minutes before broiling again. Leaving the oven in the broil modes for long periods of time may trip the oven's thermal protection circuit, requiring a service call to reset it.

IMPORTANT:

- Before starting the oven, position the oven rack(s) at the proper height(s). If the oven is warm, use potholders for safety.

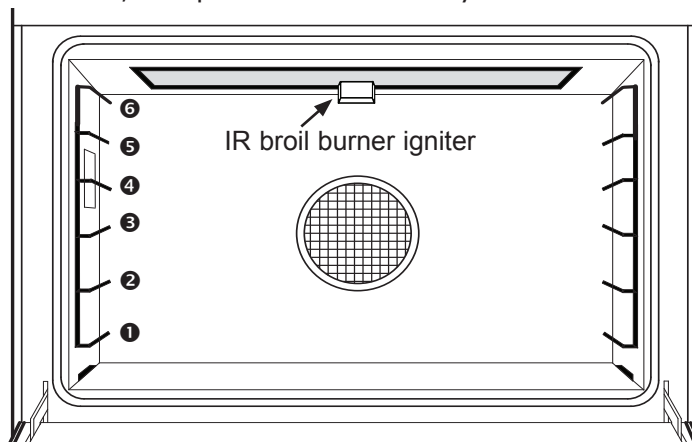

- Before using the oven for the first time, perform the burn-in process on page 8.
- Condensation may appear on the oven window or the backguard during the first 10 minutes of operation. This condition is normal.

To Bake:

1. Turn the oven control (center) knob on the control panel to the desired baking temperature. Do not turn the knob all the way to the **BROIL** setting. The oven ON indicator light will illuminate to indicate the oven is on. Within 60 seconds, the bake burner will ignite.

Oven burner light on control panel

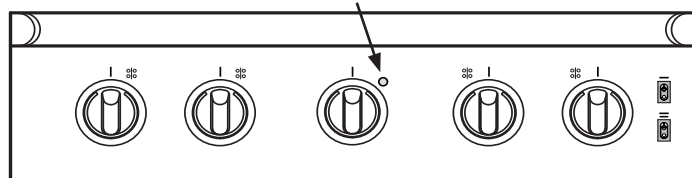

2. For best results, do not place food inside the oven until the oven has preheated to the set temperature. When pre-heated to the set temperature, the oven ON indicator light will begin to turn on and off every few seconds, because the set temperature has been reached and the oven is maintaining it.

To Convection Bake:

1. Pre-heat the oven according to the **Bake** instructions above.
2. When pre-heated, place the food in the oven.
3. Close the oven door and turn the **CONVECTION FAN** switch on the right side of the control panel to the **"ON"** position.

Operating Your Range

To Broil:

1. Adjust the rack position based on the food thickness. Dacor recommends rack levels 4 or 5.
2. Turn the oven control (center) knob on the control panel to the **BROIL** setting. The oven ON indicator light will illuminate to indicate the oven is on. Within 60 seconds, the burner (on the ceiling) will ignite. While the broil burner is on, the bake burner is off.
3. Immediately place the food inside the oven and close the door completely.

IMPORTANT:

- Always use a broiler pan and grill to provide drainage for excess fat and grease. Doing so will reduce spatter, smoke, and flare-ups.
- The igniter for the IR broil burner on the ceiling of the oven will glow orange periodically during normal broil operation.

To Convection Broil:

1. Set the oven to broil according to the **Broil** instructions at the left.
2. Immediately place the food inside the oven and close the door completely.
3. Turn the **CONVECTION FAN** switch on the right side of the control panel to the **"ON"** position.

Baking Tips

Tips for All Baking Modes

- Do not open the oven door frequently during baking. Look through the door window to check the progress of baking whenever possible.
- Use a timer to time baking functions.
- Wait until the shortest recommended baking time before checking food. For cakes, a wooden pick placed in the center should come clean when the food is done.
- Measure ingredients carefully and follow tested recipes for best baking results.

COMMON PROBLEMS WHEN USING STANDARD BAKE MODE

Problem	May Be Caused By	What to Do
Cookies burn on the bottom.	Oven door opened too often.	Set timer to shortest recommended cooking time and check food when timer beeps. Use door window to check food.
	Incorrect rack position used.	Change rack position.
	Dark, heat absorbing cookie sheets used.	Use shiny, reflective cookie sheets.
Cookies are too brown on top.	Rack position being used is too high.	Change rack position.
	Food placed in oven during preheat.	Wait until oven is preheated.
Cakes burn on the sides or are not done in the center.	Oven temperature too high.	Reduce oven temperature.
	Dark, heat absorbing cake pans used.	Use shiny, reflective cake pans.
Cakes crack on top.	Oven temperature too high.	Reduce oven temperature.
Cakes are not level.	Oven and/or oven rack not level.	Level oven and rack as needed.
Pies burn around the edges or are not done in the center.	Oven temperature too high.	Reduce oven temperature.
	Dark, heat absorbing pans used.	Use shiny, reflective pans.
	Oven and/or rack over-crowded.	Reduce number of pans.

Operating Your Range

Baking Tips (cont.)

Convection Bake Tips

- As a general rule, convection bake will allow preparation of most foods at reduced temperatures for shorter periods of time, while also producing superior results.
- Typically you can reduce the standard temperature by 25°F and cook for 10% less time. Baked goods will have golden-brown crusts with flaky textures, and meats will have crispy exteriors with succulent juices sealed inside.
- To convert conventional bake recipes to convection recipes, reduce temperature by 25°F and the cooking time by approximately 10%.
- Some recipes, especially those that are home-made, may require adjustment and testing when converting from standard to convection modes. If unsure how to convert a recipe, begin by preparing the recipe in bake mode. After achieving acceptable results, follow the convection guidelines listed. If the food is not prepared to your satisfaction during the first convection trial, adjust only one recipe variable at a time (such as cooking time, rack position or temperature) and repeat the convection test. If necessary, continue adjusting one recipe variable at a time until you achieve satisfactory results.

About Convection Baking...

The Dacor convection cooking system distributes the heated air evenly to ensure uniform results. It also channels the air evenly into the oven, eliminating any hot or cool spots.

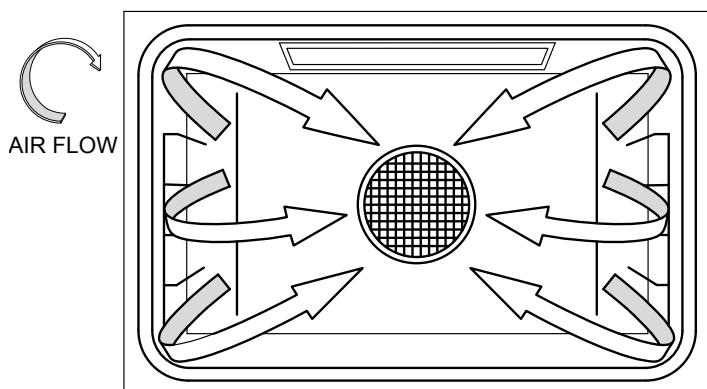

Bakeware Tips

- Dacor's optional full-sized cookie sheets maximize baking capabilities by utilizing the most usable rack space. See the **Accessories** section for ordering information.
- Use the pan size and type recommended by the recipe to ensure best results.
- Cakes, quick breads, muffins and cookies should be baked in shiny, reflective pans for light, golden crusts.
- Medium gauge aluminum sheets with low sides should be used when preparing cookies, biscuits and cream puffs.
- Bake most frozen foods in their original foil containers placed on a flat cookie sheet. Follow the package recommendations.
- When using glass bakeware, reduce the recipe temperature by 25°F, except when baking pies or yeast breads.
- Follow the standard recipe baking time for pies and yeast breads.
- Avoid the use of old, darkened pans.
- Warped, dented, stainless steel and tin-coated pans heat unevenly and will not give uniform baking results.
- Place pans carefully on the oven racks. Turn pans on the racks so that the long sides run left to right, parallel to the door.

Multiple Rack Baking

You can utilize more oven capacity due to the uniform air circulation provided by convection cooking. Many foods, such as pizzas, cakes, cookies, biscuits, muffins, rolls and frozen convenience foods can be successfully prepared on either two or three racks at the same time. Also, complete meals can be prepared by using multiple racks. See below for specific recommendations.

MULTIPLE RACK BAKING TIPS

- Typically, when baking on two racks, use rack positions 2 and 4.
- When adapting a single rack recipe to multiple rack baking, it may be necessary to add to the baking time. This is due to the extra amount of food in the oven.

Operating Your Range

Broiling Tips

Broiling is a quick and flavorful way to prepare many foods, including steaks, chicken, chops, hamburgers and fish.

It is normal and necessary for some smoke to be present to give the food a broiled flavor.

- Dacor recommends that you set a timer to time the broiling process.
- Start with a room temperature broiler pan for even cooking.
- Use tongs or a spatula to turn and remove meats. Never pierce meat with a fork because the natural juices will escape.
- Broil food on the first side for a little more than half of the recommended time, then season and turn. Season the second side just before removing the food from the oven.
- To prevent sticking, lightly grease the broiler grill. Excess grease will result in heavy smoke. For easier cleaning, remove the broiler pan and grill when the food is removed.

Roasting Tips

- Dacor's optional roasting pan works particularly well and two of them will fit side by side in your oven.
- For roasting, Dacor's optional "V" shaped rack and broil/roast pan works best to allow air circulation around the food.

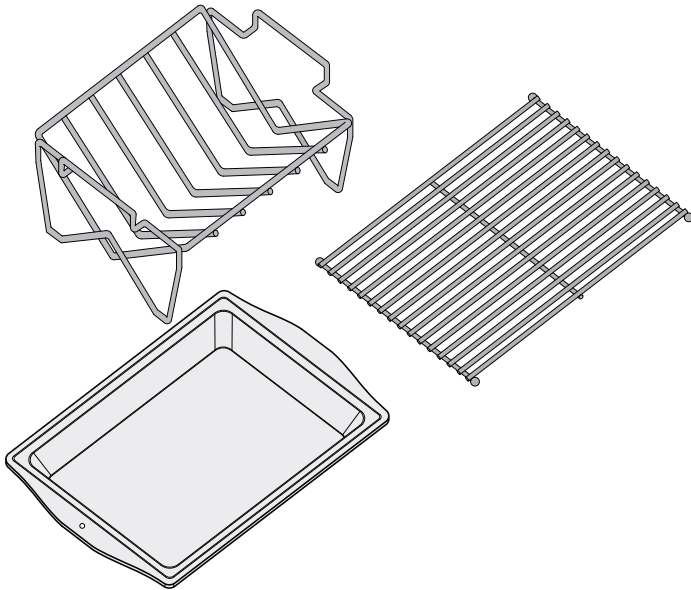

- If using a cooking bag, foil tent or other cover, use convection bake mode. Adjust the recipe time and temperature as well.

- When using a meat thermometer, insert the probe halfway into the center of the thickest portion of the meat. For poultry, insert the thermometer probe between the body and leg into the thickest part of the inner thigh. To ensure an accurate reading, the tip of the probe should not touch bone, fat or gristle. Check the meat temperature 2/3 of the way through the recommended roasting time. After reading the meat thermometer once, insert it 1/2 inch further into the meat, then take a second reading. If the second temperature registers below the first, continue cooking the meat.
- Allow roasts to stand 15 to 20 minutes after roasting in order to make carving easier.
- Roasting times always vary according to the size, shape and quality of meats and poultry. Less tender cuts of meat are best prepared in bake mode and may require moist cooking techniques. Follow your favorite cookbook recipes.

High Altitude Cooking

Due to the lower atmospheric pressure at higher altitudes, foods tend to take longer to cook. Therefore, recipe adjustments should be made in some cases. In general, no recipe adjustment is necessary for yeast-risen baked goods, although allowing the dough or batter to rise twice before the final pan rising develops a better flavor. Try making the adjustments below for successful recipes. Take note of the changes that work best and mark your recipes accordingly. You may also consult a cookbook on high altitude cooking for specific recommendations.

Altitude (feet)	Baking Powder for each teaspoon decrease by:	Sugar for each teaspoon decrease by:	Liquid, for each cup add:
3000	5-10%	10-25%	5-10%
5000	10%	10%	20%
7000	25%	20%	20-25%

Care and Cleaning

Cleaning

WARNING

- Clean only the parts of the range listed in this manual. Clean them only in the manner specified.
- To avoid dangerous fumes or damage to your range's surfaces and accessories, use only the types of cleaning solutions specified in this manual.
- To avoid electrical shock or burns, turn off the burners and oven and make sure that all parts are cool before cleaning. **DO NOT** turn the burners on during cleaning.
- Do not use a steam cleaner to clean the range. Steam could penetrate the electrical components and cause a short circuit.
- To reduce the chance of electric shock. Disconnect the range power cord from the electrical outlet before cleaning.

WARNING

- Do not try to remove heavy spills with a sharp object such as a knife or metal spatula. Sharp objects may scratch your range's surfaces.
- To prevent damage, do not use abrasive or corrosive cleaners or applicators such as steel wool or scouring pads on any part of the range unless instructed to do so. Use only a sponge, soft cloth, fibrous or plastic brush, or nylon cleaning pad for cleaning the surfaces of your range.

To keep the range looking and operating its best, clean it after every use. Also, wipe up spills that occur while cooking quickly. Be careful not to touch any hot areas.

If you allow spills to sit on hot burner parts, they will burn on and be very difficult to clean. Certain types of food, such as tomatoes, citrus juices, vinegar, alcohol and milk can damage the finishes if you allow them to stand for any length of time.

IMPORTANT: The cooktop is exposed to extremely high temperatures. The grates are under high stress when hot utensils are placed on them. Also, the range parts are occasionally exposed to acidic food spill-overs. These severe operating conditions, cause the porcelain enamel parts on your range to undergo a change in appearance over time. If you care for and clean these parts carefully, you will slow down, but not eliminate, the aging process.

Cooktop Disassembly and Cleaning

1. Disconnect the power cord.
2. When the range is cool, remove the grates from the top of the cooktop.
3. Disassemble the burners: Lift the burner caps and burner rings off of the burner bases.

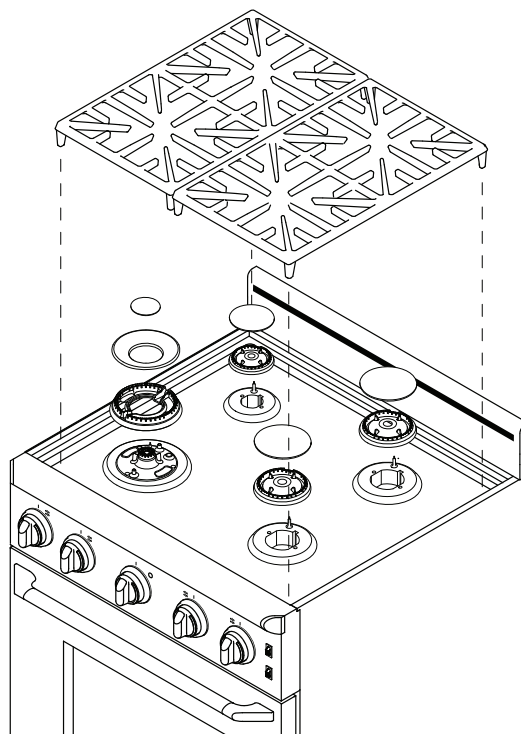

Cooktop Disassembly

Grates and Spill Trays

IMPORTANT: DO NOT use any of the cleaners listed below to clean the burners and igniters. See the facing page for burner and igniter cleaning instructions.

The grates and spill tray are coated with a porcelain finish.

- For everyday cleaning, use a soft cloth or non-abrasive pad with warm soapy water to clean all of the porcelain parts.
- If necessary, tough stains may be removed by applying full-strength sprays such as Simple Green™, Ajax™ All-Purpose Cleaner or Formula 409™. To minimize wear, use the mildest cleaner needed to get the surface clean.
- For extremely stubborn stains, you may use a mildly abrasive cleaner or applicator, such as Soft Scrub™, Bon Ami™, S.O.S.® pads or other soap-filled steel wool pads. **Use these cleaners with extreme care and only on occasion.** Aggressive or extensive use of these types of abrasives will damage the finish. **Finish damage due to the use of abrasives is not covered under your warranty.**

Care and Cleaning

Cleaning the Burners and Igniters

WARNING

Use care while cleaning the igniters. The porcelain is fragile and can crack or break.

IMPORTANT: The igniters will not work properly if the burner rings, burner bases or igniters are not clean. Dirty or wet igniters may not spark at all.

After disassembling the burners, check for any dirt or grime deposited on the individual parts, including the igniters.

1. Using a firm toothbrush, clean completely around the metal top and porcelain base of the igniter. Use care while cleaning because the porcelain is fragile and can crack or break. Do not use water to clean the igniters. If necessary, use a small amount of rubbing alcohol to help dissolve grime.
2. Examine the burner rings. Remove anything stuck in the holes with a straightened paper clip, wire or needle. Be careful not to scratch or damage it. Do not distort the shape of the holes.
3. Clean all the burner rings, with window cleaner or rubbing alcohol. Use a cleaning brush with plastic bristles or a firm tooth brush. When done, rinse the parts well with clean water. Dry all the parts thoroughly before re-assembling them.
4. Clean the burner caps with a solution of mild detergent and hot water.
5. Reassemble the cooktop in the reverse order (see page 6 for detailed instructions). Make sure you line up the notches on the burner rings.
6. Re-connect the power cord and test the burners after reassembling them. If the flame is uneven, be sure that all the burner parts are properly positioned, then check for any remaining dirt or grime on the burner parts or igniter. If erratic clicking is still present, make sure the igniter is completely dry. If the unit still exhibits problems after drying, call your local Dacor authorized service agent.

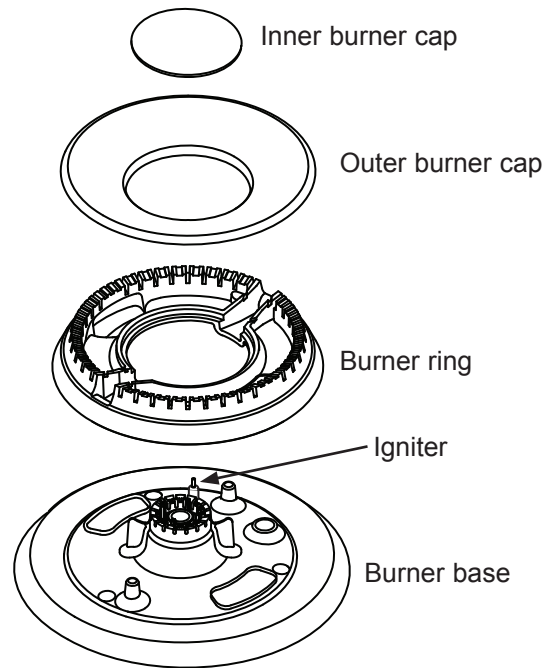

Dual Burner
(left front burner only)

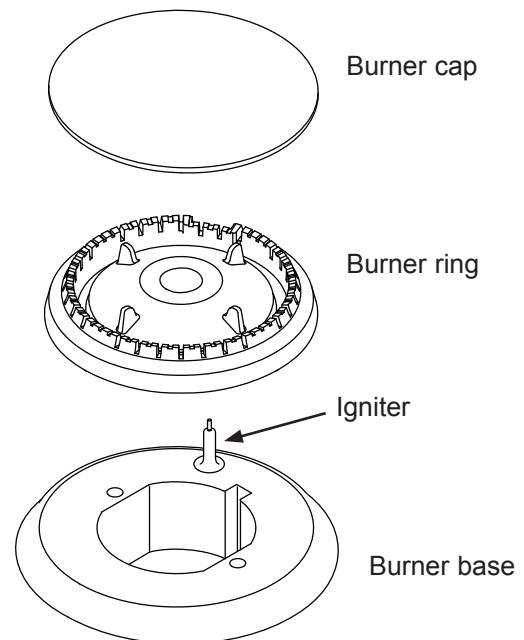

Standard Burner
(right front, right rear, left rear burners)

Care and Cleaning

Cleaning (cont.)

Knobs and Trim Rings

WARNING

- Do not operate the cooktop without the knobs and spill protector rings in place.
- Do not soak the knobs and spill protector rings in water or place them in the dishwasher.
- Do not expose the knobs or spill protector rings to direct flame, hot utensils or other sources of heat.

Wash the knobs regularly with a solution of warm soapy water. Dacor recommends hand dishwashing liquid. To clean:

1. Disconnect power and turn the knobs to the off position to remove them for cleaning or replacement.
2. Grasp each knob and pull straight back, off of the valve shaft.
3. Clean the outside edges of the trim rings while the knobs are removed. Wipe them with a soft damp rag.

4. To replace the knobs, align the "D-shaped" opening on the back of the knob with the end of the valve shaft. Carefully push the knob on until it stops. The largest knob with numbers on it is the oven knob and goes on the center valve stem. The dual burner knob has the high flame icon and the simmer (low) icon spaced further apart than the other three. Place it on the valve stem that is second from the left.

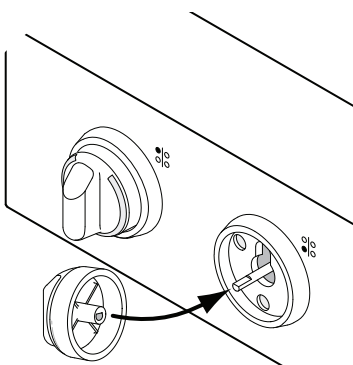

5. Reconnect the power cord.

Door Glass

Clean all glass surfaces with a solution of mild detergent and hot water. Use a mild glass cleaner to remove fingerprints or smears. Dry completely with a soft, lint-free cloth.

Stainless Steel Surfaces

The control panel, the outside surface of the oven door, the area around the outside of the cooktop and the side panels are covered with stainless steel. Clean these surfaces with the provided Dacor Stainless Steel Cleaner. Rinse and dry with a soft, lint-free cloth. *Always* wipe stainless steel surfaces with the grain. A small amount of baby oil may be applied to stainless steel tops to restore lustre.

Brass, Chrome and Copper Surfaces

Clean brass, chrome and copper surfaces the same way as stainless steel surfaces (see column one).

Porcelain Surfaces

The oven interior, the inner side of the oven door and the spill tray are finished in porcelain enamel.

Clean porcelain surfaces with a solution of mild detergent and hot water. Rinse and dry with a soft cloth. Do not use abrasives or commercial oven cleaners. You may remove the rack supports to clean the surfaces behind them more easily.

Rack Support Removal

1. With the oven cool, pull straight out on the front of the rack support, toward the center. The mounting pins on the front of the rack should disengage from the oven.
2. While holding the rack support at a 45° angle to the side of the oven, gently pull forward to disengage the rear mounting pins from the oven.

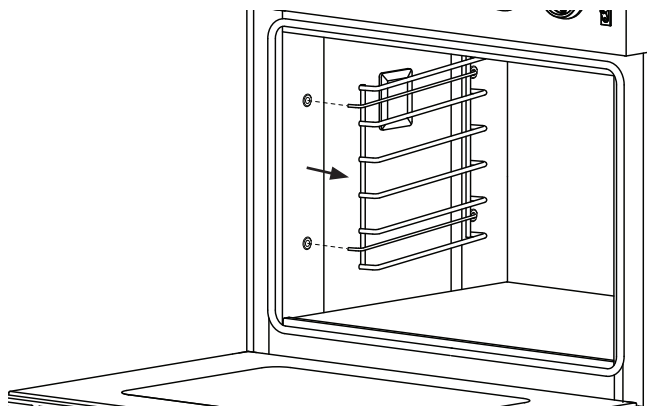

Rack Support Installation

1. One set of mounting pins on each rack support are straight, the other set is at an angle. The angular pins go toward the back of the oven. Insert them in the rear mounting holes while holding the rack support at a 45° angle to the side of the oven. To prevent damage, do not insert the rack support with the angular pins forward.
2. Rotate the front of the rack towards the wall of the oven. Slide the front rack pins into the front mounting holes.

Oven Racks and Rack Supports

- See above for instructions on removing the rack supports.
- The oven racks and rack supports are chrome-plated. For everyday cleaning, apply a solution of detergent and hot water. To clean heavy soil, use the rough side of a sponge or a scouring pad with plenty of water, or use a solution of 1 cup ammonia to 2 gallons of water.

Care and Cleaning

IR (Infrared) Broil Burner

WARNING

To prevent damage to the broil burner, do not spray the burner or its igniter with any type of cleaner or attempt to scrub them in any manner.

The IR broil burner is self-cleaning. To burn off any grime build-up, close the oven door and turn the oven control knob to the **BROIL** position for about ten minutes. After ten minutes turn the oven off.

Convection Filter (Oven)

WARNING

- The convection filter is made of stainless steel. Remove it only when it is cool.
- Re-install the filter before cooking in the oven again. Failure to do so will expose the convection fan blade that rotates at high speed during convection modes.

Convection Filter Removal and Cleaning

- Remove the filter regularly for cleaning. A clogged filter will reduce the effectiveness of convection cooking. Soak it in hot soapy water. Dry it completely before re-installing.

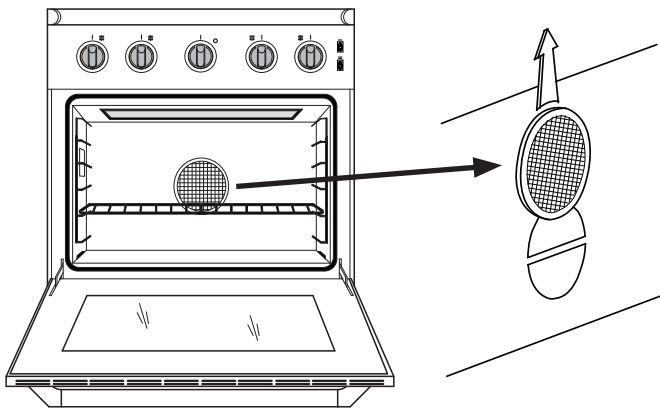

- To reinstall the filter, orient it so that the mounting clips are towards the rear of the oven chamber, open end down. Hook the mounting clips over the horizontal bar across the opening.

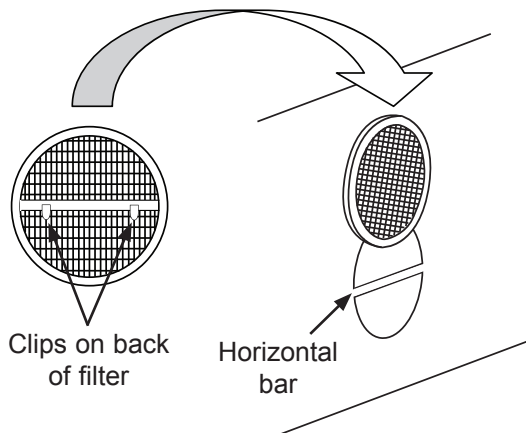

Replacing the Oven Light

WARNING

- To prevent an electrical shock hazard and/or personal injury, make sure that power to the range has been disconnected and that the light fixture is cool before replacing the light bulb.
- Always ensure that the lens cover is in place when using the oven. The lens cover protects the bulb from breakage caused by high oven temperatures or mechanical shock.
- Replacing the lens cover without lining up the cutout with the light socket will damage the light fixture.
- Do not use a screwdriver to remove the lens.

Replacing a Light Bulb

Light bulb replacement is considered a homeowner maintenance operation. If the light does not work, before replacing it, please consult the **Problem Solution Guide** on page 18.

1. Replace the light bulb only with Dacor part number 100429 (visit www.everthingdacor.com). **IMPORTANT:** Do not touch the replacement halogen light bulb with your fingers. Halogen bulbs are sensitive to the oils from your hand. The oils from your hand will stick to the bulb and may cause it to burn out faster than normal.
2. Disconnect the range power cord from the electrical outlet.
3. Remove the left rack support. See facing page.
4. Hold your hand under the lens for support and gently pry it loose using a spatula or table knife. Pull the lens cover straight out.
5. Grasp the old bulb and pull it straight out of the socket.
6. Using a glove, insert the new bulb into the socket.
7. As you reinstall the lens cover, line up the cutout on the inside rim with the light socket. Gently press it into its original position.
8. Replace the left rack support and reconnect the power cord.

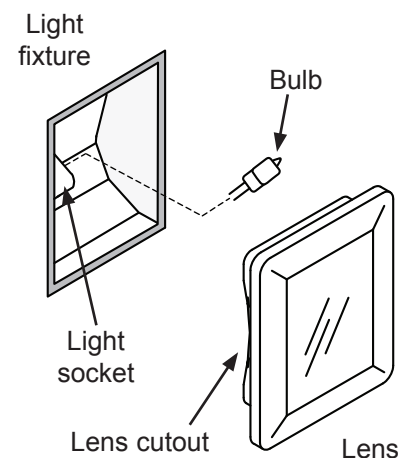

Before You Call for Service

Problem	May Be Caused By	What to Do
Nothing works.	Range not connected to electrical power.	Check to make sure range power plug is connected to electrical outlet.
	Power is off.	Turn on power at circuit breaker or fuse box for electrical outlet range is connected to. Check for tripped breaker or blown fuse.
	Power outage.	Contact power company.
Igniters do not spark.	Power not supplied to unit.	See Nothing Works above.
	Wet or dirty igniter.	Clean and dry igniter and burner assembly according to Care and Cleaning section.
No flame.	Igniter not working (no clicking sound).	See Igniters do not spark above.
	Wet or dirty igniter.	Clean and dry according to Care and Cleaning section.
	Gas is turned off.	Make sure the gas supply valve is in the "ON" position.
	Gas supply interrupted.	Contact gas company.
Burner goes out at low setting.	Low gas pressure.	Contact gas company to have pressure tested.
	Air intake holes obstructed.	Check to make sure none of the air slots on range are obstructed.
Flame is distorted, yellow or very large.	Burner parts are dirty or clogged.	Clean and dry according to Care and Cleaning section.
	Burner parts are not properly positioned.	Make sure burner is assembled according to the Setting Up Your Range section.
	Range set up to use a different type of gas (natural or LP) or set up for different altitude.	Have a qualified service technician check to make sure that the range is set up for the type of gas and the correct altitude.
	Gas regulator is not installed or faulty.	Have a qualified service technician check the gas regulator.
Igniter continues to spark (click) after flame ignites.	Burner is cold.	Burners may continue to spark for up to 60 seconds when cold and set to low. See Operating Your Range section for more information on how to minimize.
	Flame distorted by air draft.	Minimize any air drafts around the cooktop. Close nearby windows.
	Wet or dirty igniter.	Clean and dry according to Care and Cleaning section.
	Burner parts wet or dirty.	Clean and dry according to Care and Cleaning section.
	Burner parts not properly positioned.	Make sure burner is assembled according to the Setting Up Your Range section.
	Power supply polarity is reversed or not properly grounded.	Have a licensed electrician check the electrical outlet.
Orange glow on ceiling of oven when broiling.	Normal operation.	The IR broil burner igniter glows orange off and on when the oven knob is set to broil.

Before You Call for Service

Problem	May Be Caused By	What to Do
Oven will not heat when turned on.	No power to range.	See Nothing Works on facing page.
	Gas is turned off.	Make sure the gas supply valve is in the "ON" position.
	Gas supply interrupted.	Contact gas company.
Oven light will not work.	Light bulb is burned out.	See Care and Cleaning section.
Oven ON indicator light goes on and off repeatedly.	Normal operation.	The oven ON indicator light illuminates when the oven is on. The oven burner control system turns the oven off and on to maintain the temperature set by the oven control knob.
Foods over-cook.	Incorrect cooking time, temperature.	Adjust time, temperature or rack position.
Foods under-cook.	Incorrect cooking time, temperature	Adjust time, temperature or rack position.
Condensation on oven door window	Cold weather.	During cold weather it is normal for condensation to appear on the oven door window during the first 10 minutes of operation.
Strange odor when oven is on.	Residue in oven.	During manufacturing, certain residues can be left on oven surfaces. Oven needs to be "Burned In," see page 8.

Warranty and Service

Getting Help

Before you request service:

1. Review **Before You Call for Service** section of this manual (see page 19).
2. Use the helpful tips found in our **Problem Solution Guide**.
3. Become familiar with the warranty terms and conditions of your product.
4. If none of these tips or suggestions resolves your problem, call our Customer Service center at the number below.

Dacor's Customer Service center is available 6:00 A.M. – 5:00 P.M. Pacific Time

For warranty repairs or questions and for Dacor Distinctive Service (DDS) in the US and Canada
Phone: (800) 793-0093, extension 2822

For non-warranty repairs or questions in the US and Canada
Phone: (800) 793-0093, extension 2813

Contact us through our web site at:

www.dacor.com/contact-us

Warranty and Service

Warranty

What Is Covered

CERTIFICATE OF WARRANTIES: DACOR RANGES

WITHIN THE FIFTY STATES OF THE U.S.A., THE DISTRICT OF COLUMBIA AND CANADA*:

FULL ONE-YEAR WARRANTY

The warranty applies only to the Dacor appliance sold to the first use purchaser, starting from the date of original retail purchase or closing date for new construction, whichever period is longer. Warranty is valid on products purchased brand new from a Dacor Authorized Dealer, or other seller authorized by Dacor.

If your Dacor product fails to function within one year of the original date of purchase, due to a defect in material or workmanship, Dacor will remedy it without charge to you.

All cosmetic damage (such as scratches on stainless steel, paint/porcelain blemishes, etc.) to the product or included accessories must be reported to Dacor within 60 days of the original purchase date to qualify for warranty coverage.

Consumable parts such as filters and light bulbs are not covered and are the responsibility of the purchaser.

LIMITATIONS OF COVERAGE

Service will be provided by a Dacor designated service company during regular business hours. Please note service providers are independent entities and are not agents of Dacor.

Dealer display and model home display products with a production date greater than 5 years, products sold "As Is," and products installed for non-residential use, which include but not limited to religious organizations, fire stations, bed and breakfast, and spas carry a one year parts warranty only. All delivery, installation, labor costs, and other service fees are the responsibility of the purchaser.

Warranty will be null and void on product that has altered, defaced, or missing serial numbers and tags.

The owner must provide proof of purchase or closing statement for new construction upon request. All Dacor products must be accessible for service.

*Warranty is null and void if non-ETL or non-CUL approved product is transported from the U.S.A.

OUTSIDE THE FIFTY STATE S OF THE U.S.A., THE DISTRICT OF COLUMBIA AND CANADA:

LIMITED FIRST YEAR WARRANTY

If your Dacor product fails to function within one year of the original date of purchase due to a defect in material or workmanship, Dacor will furnish a new part, F.O.B. factory to replace the defective part.

All delivery, installation, labor costs, and other service fees are the responsibility of the purchaser.

What Is Not Covered

- Slight color variations may be noticed because of differences in painted parts, kitchen lighting, product placement, and other factors; this warranty does not apply to color variation.
- Service calls to educate the customer on proper use and care of the product.
- Service fees for travel to islands and remote areas, which include but not limited to, ferries, toll roads or other travel expenses.
- Consequential or incidental damage, including but not limited to food or medicine loss, time away from work or restaurant meals.
- Failure of the product when used for commercial, business, rental or any application other than for residential consumer use.
- Failure of the product caused by improper product installation.
- Replacement of house fuses, fuse boxes or resetting of circuit breakers.
- Damage to the product caused by accident, fire, flood, power interruption, power surges or other acts of God.
- Liability or responsibility for damage to surrounding property including cabinetry, floors, ceilings and other structures or objects around the product.
- Breakage, discoloration, or damage to glass, metal surfaces, plastic components, trim, paint or other cosmetic finish caused by improper usage, care, abuse, or neglect.

Out of Warranty

Should you experience a service issue beyond the standard warranty period, please contact us. Dacor reviews each issue and customer concern to provide the best possible solution based on the circumstances.

THE REMEDIES PROVIDED IN THE ABOVE EXPRESS WARRANTIES ARE THE SOLE AND EXCLUSIVE REMEDIES. THEREFORE, NO OTHER EXPRESS WARRANTIES ARE MADE, AND OUTSIDE THE FIFTY STATES OF THE UNITED STATES, THE DISTRICT OF COLUMBIA AND CANADA, ALL IMPLIED WARRANTIES, INCLUDING BUT NOT LIMITED TO, ANY IMPLIED WARRANTY OF MERCHANTABILITY OR FITNESS FOR A PARTICULAR USE OR PURPOSE, ARE LIMITED IN DURATION TO ONE YEAR FROM THE DATE OF ORIGINAL PURCHASE. IN NO EVENT SHALL DACOR BE LIABLE FOR INCIDENTAL EXPENSE OR CONSEQUENTIAL DAMAGES. IN THE EVENT DACOR PREVAILS IN ANY LAWSUIT, DACOR SHALL BE ENTITLED TO REIMBURSEMENT OF ALL COSTS AND EXPENSES, INCLUDING ATTORNEY'S FEES, FROM THE DACOR CUSTOMER. NO WARRANTIES, EXPRESS OR IMPLIED, ARE MADE TO ANY BUYER FOR RESALE.

Some states do not allow limitations on how long an implied warranty lasts, or do not allow the exclusion or limitation of inconsequential damages, therefore the above limitations or exclusions may not apply to you. This warranty gives you specific legal rights, and you may also have other rights that vary from state to state.

fold here



NO POSTAGE
NECESSARY
IF MAILED
IN THE
UNITED STATES

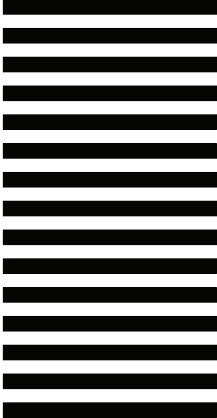

BUSINESS REPLY MAIL
FIRST-CLASS MAIL PERMIT NO 1600 CITY OF INDUSTRY CA

POSTAGE WILL BE PAID BY ADDRESSEE

**DACOR
ATTN WARRANTY PROCESSING DEPT
PO BOX 90070
CITY OF INDUSTRY CA 91715-9907**





Please visit www.dacor.com to activate your warranty online.

WARRANTY INFORMATION



IMPORTANT:

Your warranty will not be activated until you activate it online or return this form to Dacor. If you have purchased more than one Dacor product, please return all forms in one envelope or activate the warranty for each product online.

Please rest assured that under no conditions will Dacor sell your name or any of the information on this form for mailing list purposes. We are very grateful that you have chosen Dacor products for your home and do not consider the sale of such information to be a proper way of expressing our gratitude!

Owner's Name: _____
Last (Please Print or Type) First Middle

Street: _____

City: _____ State: _____ Zip: _____

Purchase Date: _____ Email: _____ Telephone: _____

Dealer: _____

City: _____ State: _____ Zip: _____

Your willingness to take a few seconds to fill in the section below will be sincerely appreciated. Thank you.

1. How were you **first** exposed to Dacor products? (Please check one only.)

- A. T.V. Cooking Show
- B. Magazine
- C. Appliance Dealer Showroom
- D. Kitchen Dealer Showroom
- E. Home Show
- F. Builder
- G. Architect/Designer
- H. Another Dacor Owner
- I. Model Home
- J. Other _____

2. Where did you buy your Dacor appliances?

- A. Appliance Dealer
- B. Kitchen Dealer
- C. Builder Supplier
- D. Builder
- E. Other _____

3. For what purpose was the product purchased?

- A. Replacement **only**
- B. Part of a Remodel
- C. New Home
- D. Other _____

4. What is your household income?

- A. Under \$75,000
- B. \$75,000 – \$100,000
- C. \$100,000 – \$150,000
- D. \$150,000 – \$200,000
- E. \$200,000 – \$250,000
- F. Over \$250,000

5. What other brands of appliances do you have in your kitchen?

- A. Cooktop _____
- B. Oven _____
- C. Dishwasher _____
- D. Refrigerator _____

6. Would you buy or recommend another Dacor product?

- Yes
- No

Comments: _____

Thank you very much for your assistance. The information you have provided will be extremely valuable in helping us plan for the future and giving you the support you deserve.



cut here

cut here